

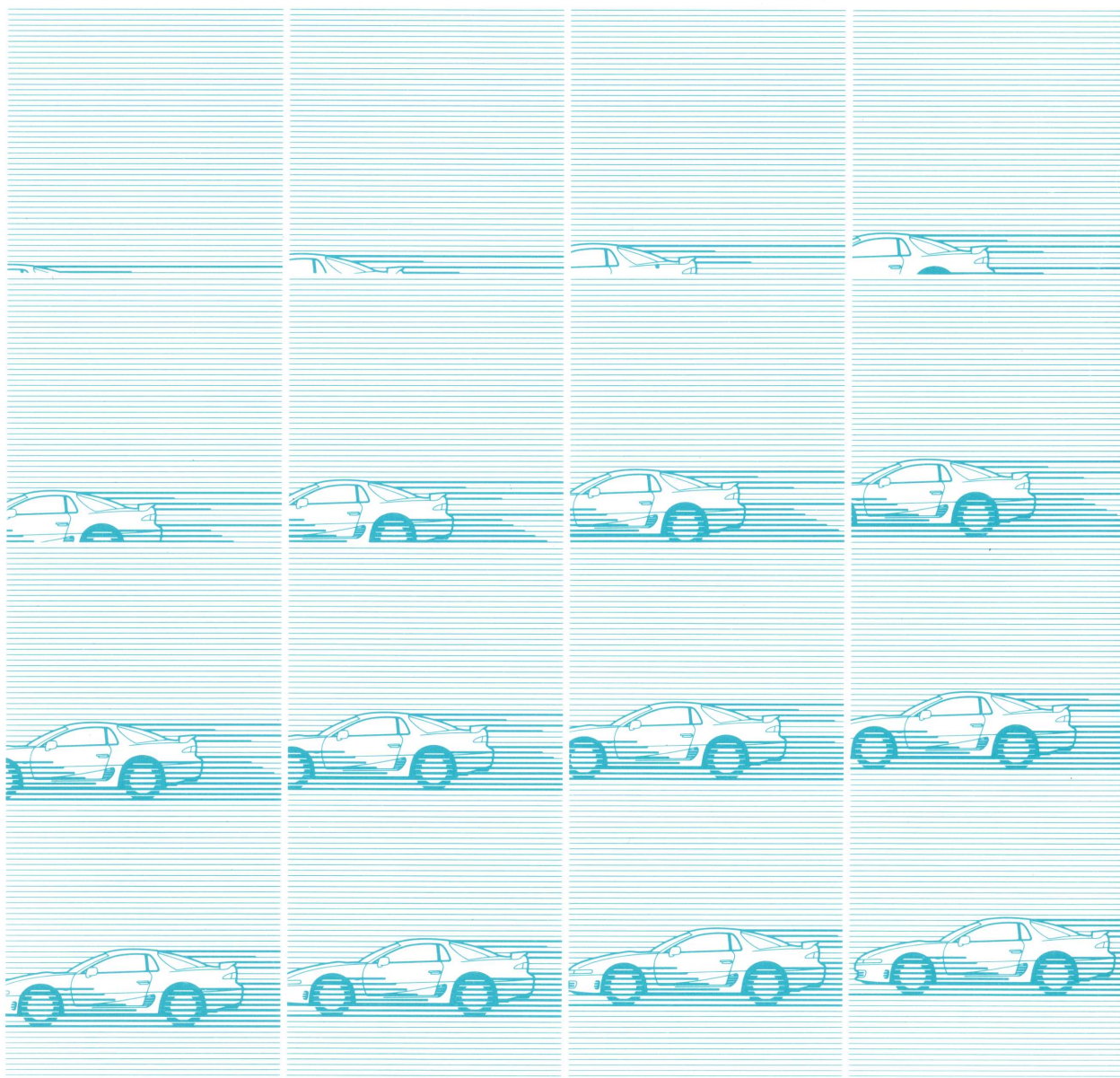

CONFIDENTIAL

Technical Information Manual

3000GT '93



Pub. No. PYUE9201

This page intentionally left blank.

MITSUBISHI 3000GT

TECHNICAL INFORMATION MANUAL

FOREWORD

This manual has been prepared as an introduction to the specifications, features, construction, functions, etc. of the newly developed 3000GT. Please read this manual carefully so that it will be of assistance for your service and sales activities. Please note that the following service manuals are also available and should be used in conjunction with this manual.

WORKSHOP MANUAL

ENGINE GROUP

PWEE
(Looseleaf edition)

CHASSIS GROUP

PWUE9119 (Vehicles
for Europe)
PWUE9203
(Vehicles for
General Export
and Australia)

ELECTRICAL WIRING

PHUE9201
(Vehicles for Europe)
PHUE9203 (Vehicles
for General Export
and Australia)

PARTS CATALOGUE

B608K402AD
(Vehicles for Europe)
B808K402AD
(Vehicles for General
Export) BFA8K402A1
(Vehicles for
Australia)

All information, illustrations and product descriptions contained in this manual are current as at the time of publication. We, however, reserve the right to make changes at any time without prior notice or obligation.

GROUP INDEX

GENERAL	0
ENGINE	1
POWER- TRANSMISSION COMPONENTS	2
DRIVE-CONTROL COMPONENTS	3
BODY	4
EXTERIOR	5
INTERIOR	6
EQUIPMENT	7



MODEL INDICATIONS

The following abbreviations are used in this manual for classification of model types.

M/T: Indicates the manual transmission, or models equipped with the manual transmission.

MPI: Indicates the multi-point injection, or engines equipped with the multi-point injection.

4WD: Indicates the 4 wheel-drive vehicles.

DOHC: Indicates an engine with the double overhead camshaft, or a model equipped with such an engine.

INDICATION OF DESTINATION -

Europe, General Export, Australia, New Zealand and GCC used for convenience to indicate destination.

NOTE

1. "General Export" means territories other than Europe, Australia, New Zealand, GCC, the U.S.A. and Canada.
2. "GCC" means member of the Gulf Cooperation Council nation.
3. In some instances, vehicles with other specifications may be shipped to some countries.

GENERAL - How to Use This Manual

EXPLANATION OF CIRCUIT DIAGRAMS

The symbols used in circuit diagrams are used as described below.

NOTE

For detailed information concerning the reading of circuit diagrams, refer to the separate manual of "ELECTRICAL WIRING".

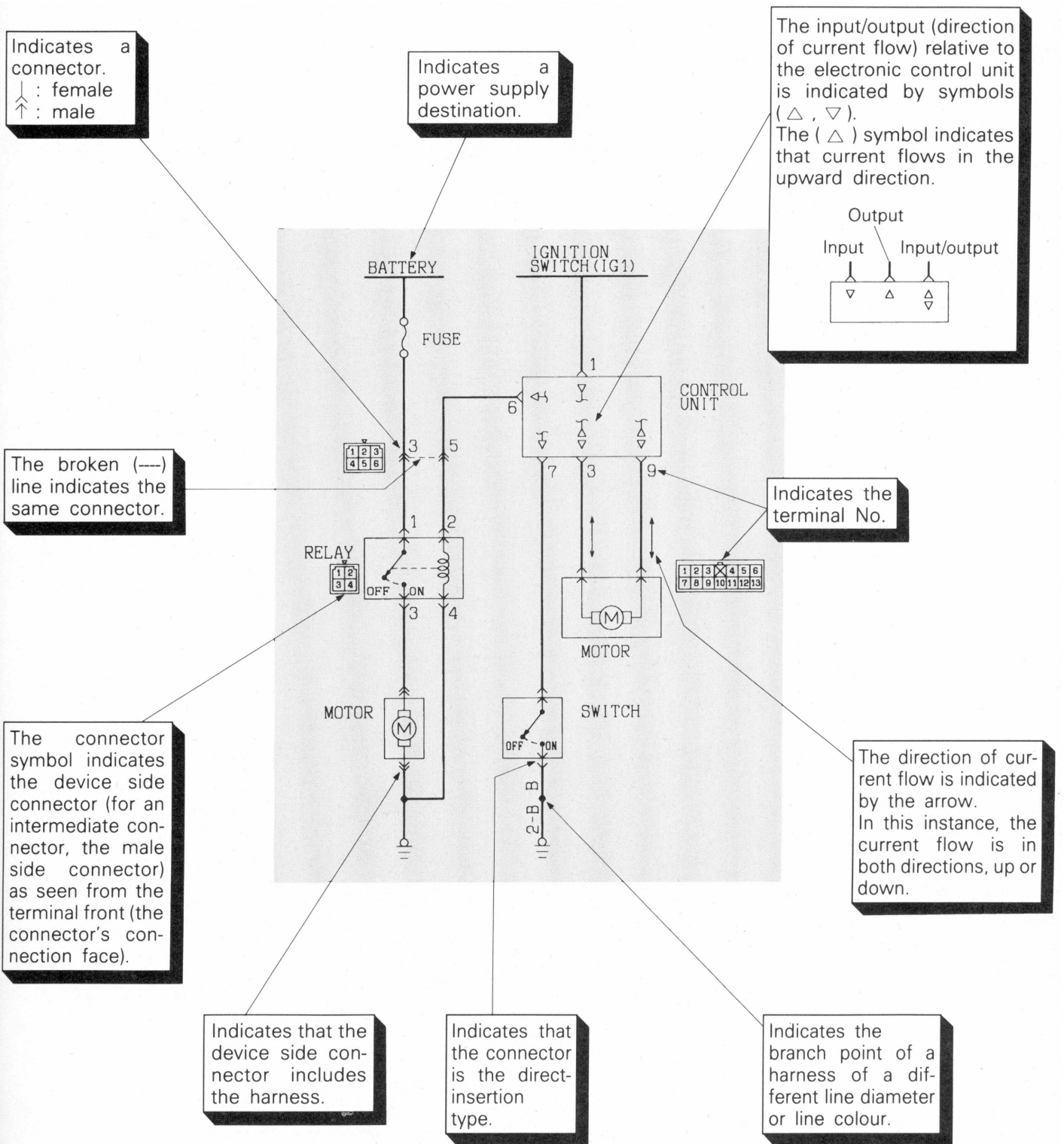

NOTES

This electronic document was created from material published and copyrighted in 1992 by Mitsubishi Motor Corporation (MMC). All rights to the original material are reserved by them.

This electronic document may be distributed freely, without financial charge. Note that this document is not an exact replica of the original manual. Because of this, copies of this document are easily identified.

MMC cannot be held liable for any changes that have occurred. Typographical and factual errors may have been introduced, and some may have been corrected, while others may have been preserved. MMC and I disclaim all liability for direct, indirect, incidental, or consequential damages or personal injury that may result from any use of the information in this manual. MMC and I make no warranty, claim, or representation, expressed or implied, concerning the accuracy of the material here, or the suitability of the information or instructions for any purpose.

Please note that this manual does not cover vehicles destined to the USA and Canada. The vehicles covered include the turbocharged model destined for Europe, Australia, New Zealand, the Gulf Coast Council (GCC) nations, and General Export (those territories other than Europe, Australia, New Zealand, GCC, USA, and Canada). In some cases, information here may be identical to that for USA and Canada vehicles. In other case, the information does not apply to USA and Canada vehicles.

I used an Epson Perfection 2450 scanner and Readiris Pro 9.04 to scan a single sheet (page) and recognize images, text, and tables. I placed a sheet of black paper behind the sheet to be scanned to reduce bleed-through of images and text from the back of the sheet or from other sheets. Scanner options in Readiris were set to grayscale, 400 dpi, letter format, and contrast and brightness set to 299 to reduce the yellowing caused by the age of the manuscript. Readiris allows the identification and selection or elimination of areas of the scanned image that are text, graphics, or table format. This did not allow the embedding of graphics into text areas or vice versa. These two areas may overlap but this created visual confusion. Pages were deskewed as necessary. The formatted, scanned page was saved in MS Word document format.

I used MS Word 2002 to make spelling corrections, format the page size (8.5" x 11"), and set margins, generally 0.5" all around. Re-arranging of objects occurred on some pages. From Word, I "printed" the page to Adobe Distiller 7.0.0, creating a PDF file for each page. Distiller was set to not compress images. This increases the size of the final document, but improves resolution and clarity of the images. In Adobe Acrobat 7.0.0, I concatenated the individual PDF files into a single document, adding bookmarks and thumbnails.

I tested the final document with Acrobat and Acrobat Reader versions 5, 6, and 7. No problems were encountered with versions 6 and 7. However, with Acrobat version 5 errors were encountered. These were avoided by having the Bookmarks panel on the left "open". I recommend using version 6 or 7 of Acrobat or Acrobat Reader to view this document.

I thank the dedication and generosity of Jan Borgelin for getting an original printed version of this publication to me.

Jeff Lucius, February 2005

GENERAL

CONTENTS

DESIGN STRATEGIES FOR DEVELOPMENT	2	Chassis	11
Basic Themes for Development	2	Supplemental Restraint System (SRS)	13
COMMODITY FEATURES	3	Small Amount Refrigerant System (Air Conditioner)	14
TECHNICAL FEATURES	4	Theft-alarm System	15
Exterior	4	Serviceability	16
Interior	5	VEHICLES IDENTIFICATION	17
Engine	6	Model	17
Transaxle	9	Model Code	17
Clutch Booster	10	MAJOR SPECIFICATIONS	18



DESIGN STRATEGIES FOR DEVELOPMENT

BASIC THEMES FOR DEVELOPMENT

New 4WD Sports Car

A 4WD system that accurately transmits the power of the engine to the road surface, thus eliminating the danger that normally accompanies speed, has been adopted in a sports car so that anyone can comfortably

drive in a sporty manner.

The DOHC twin-turbochargers and twin-intercoolers coupled with the 4WD maintain overwhelming performance

Exhilarating driving and safety

Faithful and speedy responsiveness to the intentions of the driver and direct response. Also, safety equipment has been adopted in order to maintain safety.

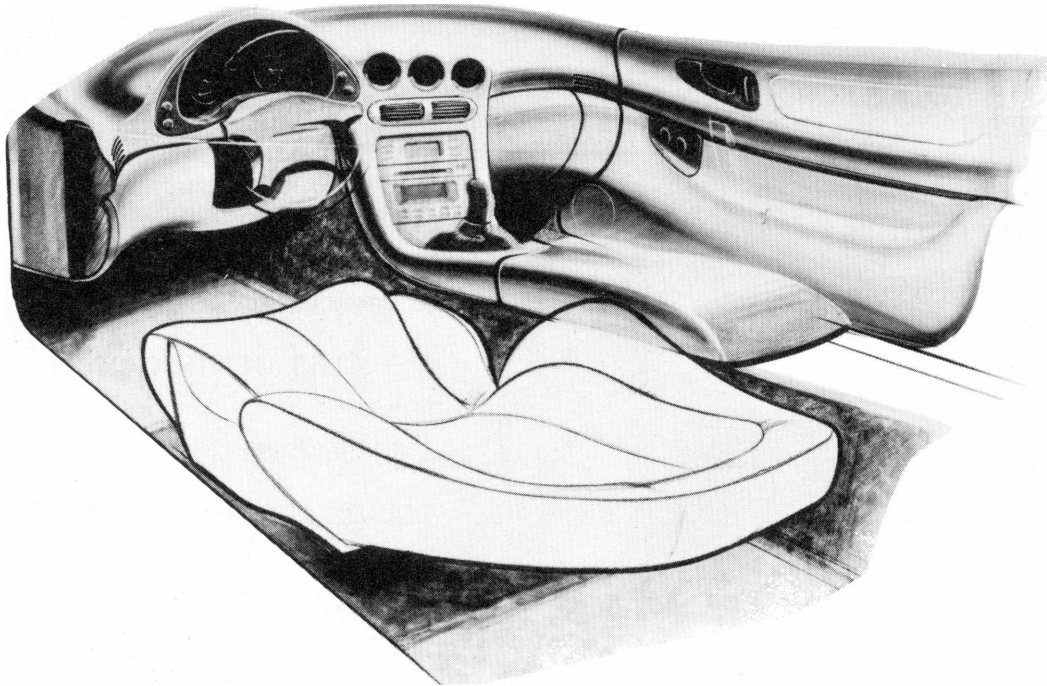

In pursuit of sports car styling

Stylish design that abolishes design compromises.

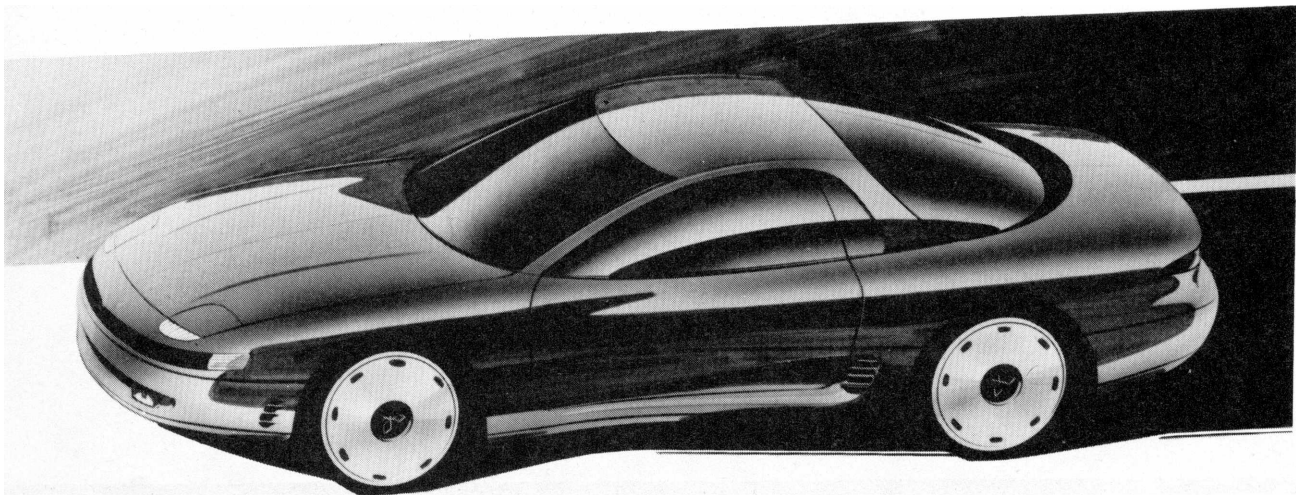

COMMODITY FEATURES

Dynamic real sports styling	}	<ul style="list-style-type: none"> • Low and wide proportions • Capsule image due to glass with complex curves • Large-diameter wide tyres that symbolize super 4WD
Interior with an abundantly sporty feel	}	<ul style="list-style-type: none"> • Sports cockpit centered around the driver • Simple interior design • Front seat which stresses driving performance
Excellent driving performance	}	<ul style="list-style-type: none"> • Excellent acceleration performance from a standing start due to a high-performance engine and 4WD
Excellent steering stability	}	<ul style="list-style-type: none"> • Extra-wide tread and wide tyres together provide a high limit for cornering performance • High-performance brakes due to the combination of 4-piston aluminum caliper brakes and 4-wheel ABS • Optimization of torque distribution to front and rear wheels
High-tech components	}	<ul style="list-style-type: none"> • Full-time 4WD and 5-speed MfT manufactured by GETRAG • Combination of 4WD, 4IS, 4ABS and 4WS • 4-piston aluminum caliper brakes • Active aero system • SRS air bag
Safety features	}	<ul style="list-style-type: none"> • 4WD • 4ABS • SRS air bag • Rear seat 3-point seat belts • High-mounted stop lamp • Side door beam • Fire-resistant materials used inside the passenger compartment

TECHNICAL FEATURES

EXTERIOR

Dynamic sports car proportions with wide tread and tight interior.

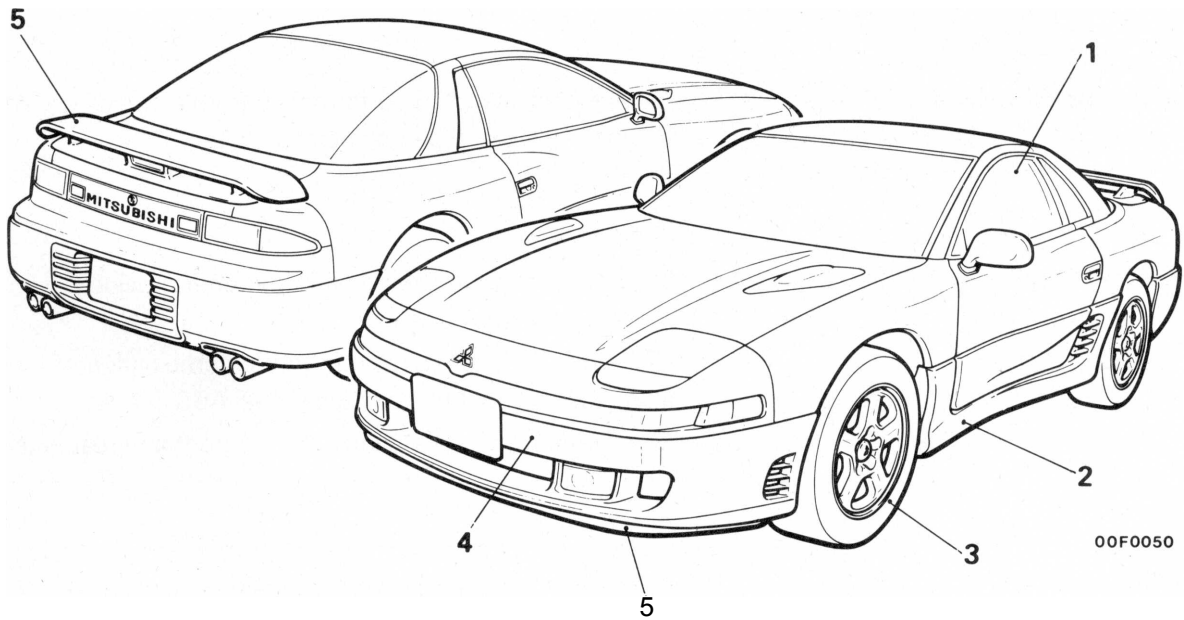

No.	Features
1	The forward passenger compartment looks like a capsule, using glass with complex curves.
2	Side air dam that provides improved aerodynamic characteristics for the side of the vehicle.
3	17" aluminum wheel and wide tread tyre to create the image of a highperformance sports car.
4	Large soft-face bumper (with built-in bumper absorber) that gives the feeling of being one unit with the body.
5	Active aero system improves aerodynamic characteristics when driving at high speed. (movable front venturi skirt and rear spoiler)

INTERIOR

Interior that creates a real feeling of a cockpit centering around the driver.

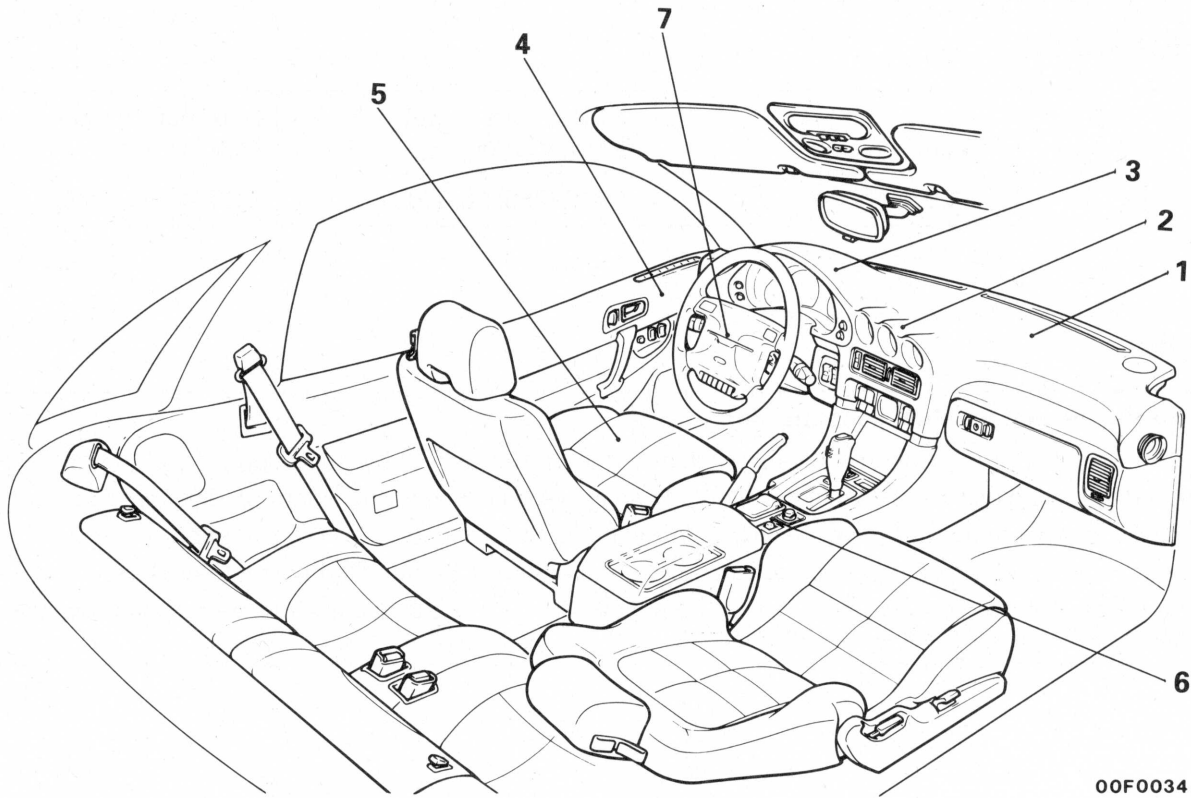

00F0034

No.	Features
1	An instrument panel that emphasizes a feeling of closeness.
2	Round 3-meter arrangement with sporty image.
3	Easy-to-see goggle type meter cluster.
4	Full round door trim that appears to be one with the instrument panel.
5	Superior sports type front seat that gives support.
6	High, wide and large floor console.
7	Sports steering wheel with built-in air bag (SRS).

ENGINE

A 3.0L DOHC engine with twin-turbochargers and twin-intercoolers have been developed to provide even higher output and higher performance.

SPECIFICATIONS

Items	Displacement cm ³ (cu. in.)	Maximum output kW (PS)/rpm	Maximum torque kgm (Nm)/rpm
Specifications	2972 (181.4)	210 (285) / 6,000	41.5 (407) /3,000

FEATURES**High performance and low fuel consumption**

- The roller rocker arm reduces the valve-actuation torque as well as fuel consumption.
- Improved response and fuel consumption have been achieved by electronic control multi-point fuel injection.
- Electronic control of fuel pump fuel discharge for high response and low fuel consumption.
- Overwhelming acceleration due to combination of the twin-turbochargers and twin-intercoolers.
- A lightweight sodium-filled vacuum valve has been developed for use as the exhaust valve to improve valve follow in high-speed ranges. <Vehicles for Europe>

Quiet operation

- Noise and vibration have been decreased by the adoption of roller rocker arms.
- Noise generated by the valve mechanism has been decreased by the hydraulic auto lash adjusters.
- Both powerful exhaust sound fitting a high performance vehicle and quietness due to the active exhaust system.
- Reduction in noise and vibration by improving the rigidity of the cylinder block.
- Vibrations have been decreased by the adoption of bearing caps with beams which increase the rigidity of the crankshaft support points.
- Reduction in vibration due to the use of a crankshaft pulley with torsion damper and, because of that, improvement in the durability of the belts.

Serviceability

- Complete self-diagnosis functions.
- Enhanced reliability through the adoption of gold-plated connector terminals.
- Use of an auto tensioner achieves maintenance-free, automatic adjustment of timing belt tension.
- Use of the auto-lash adjusters achieves maintenance-free, automatic adjustment of valve clearance.
- The 3-coil distributorless ignition system supplies sufficient ignition energy even during high speed operation.

Fuel injection
Two spray injector for injection with ideal timing due to use of high performance microcomputer.

Ignition equipment
Distributorless 3-coil ignition method for sufficient ignition energy in the high rpm range.

Ignition equipment
Platinum plugs for outstanding durability.

Moving valve construction

- Roller rocker arm with minimum friction loss in the moving valve system.
- Auto-lash adjuster to achieve maintenance-free.

Twin-turbochargers
Compact, lightweight, high efficiency turbocharger with outstanding turbo response and ideal turbo feeling from low speed to high speed.

Combustion chamber
Combustion chamber with squish area for high combustion efficiency

Crankshaft pulley
Pulley with torsional damper for minimum transmission of vibration

Auto tensioner
Auto tensioner that eliminates the need to adjust tension of timing belt and reduces noise.

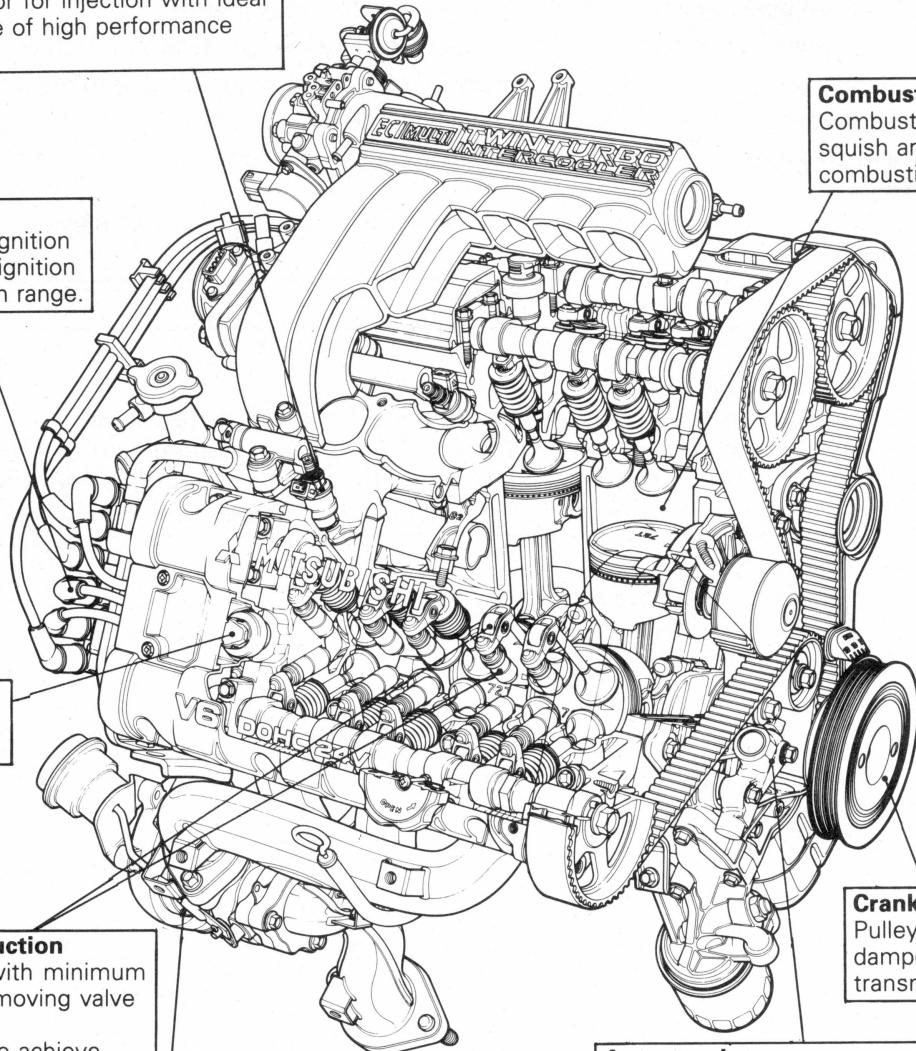

00F0041

Twin-turbochargers and Twin-intercoolers

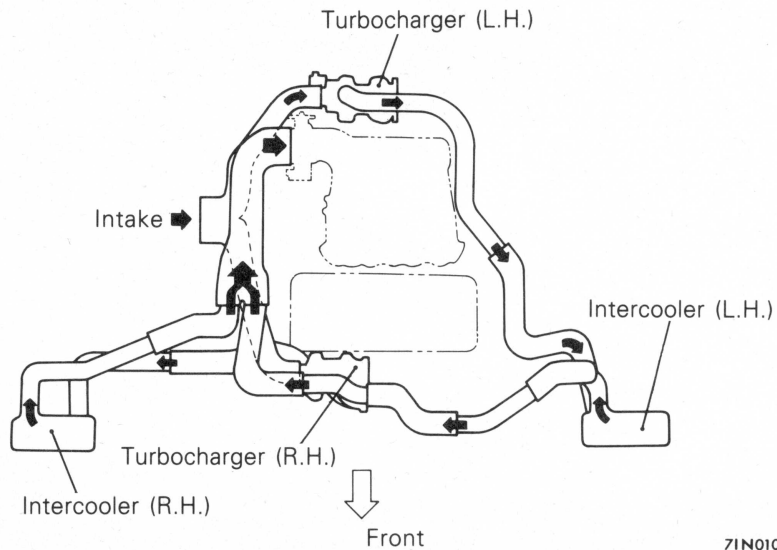

71N0107

TRANSAXLE**W5MG1 TYPE MANUAL TRANSAXLE**

The W5MG1 type manual transaxle is a full-time 4WD manual transaxle made by GETRAG* and newly

developed to match the high output and high torque of the 6G72-DOHC (Turbo) engine.

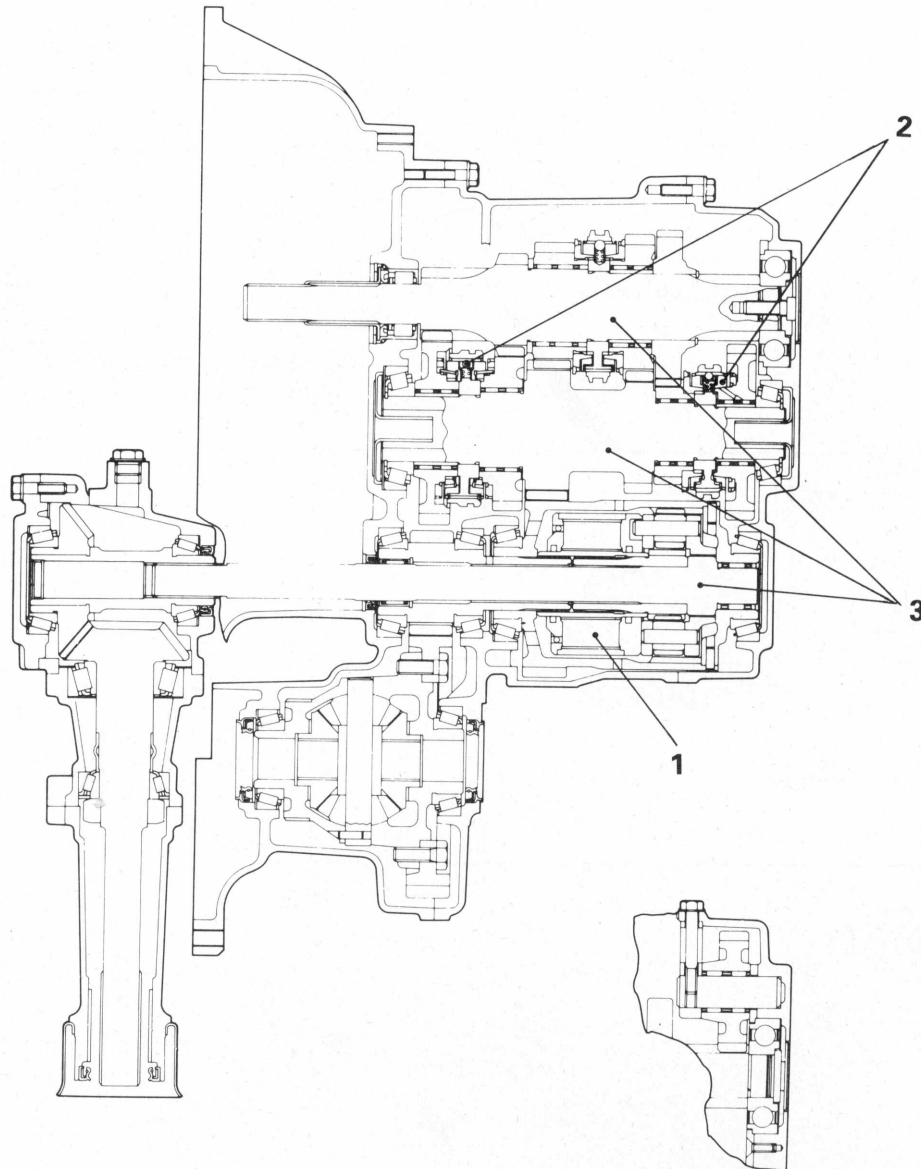

TFM0110

1. Sportier driving is possible by using a centre differential method with viscous coupling for distributing (front 45: rear 55) front and rear torque unevenly.
2. A double-cone synchronizer for 1st and 2nd speeds and a reverse synchronizer are used and, in addition to sure shifting performance, the shift feeling is also improved.
3. Low vibration and low noise are realized by the use of high precision gears and high rigidity shaft.

* GETRAG is a German manufacturer who develops and manufactures high performance transaxles especially in Europe.

CLUTCH BOOSTER

A 4" single type clutch booster is used to reduce the force needed to depress the clutch pedal.

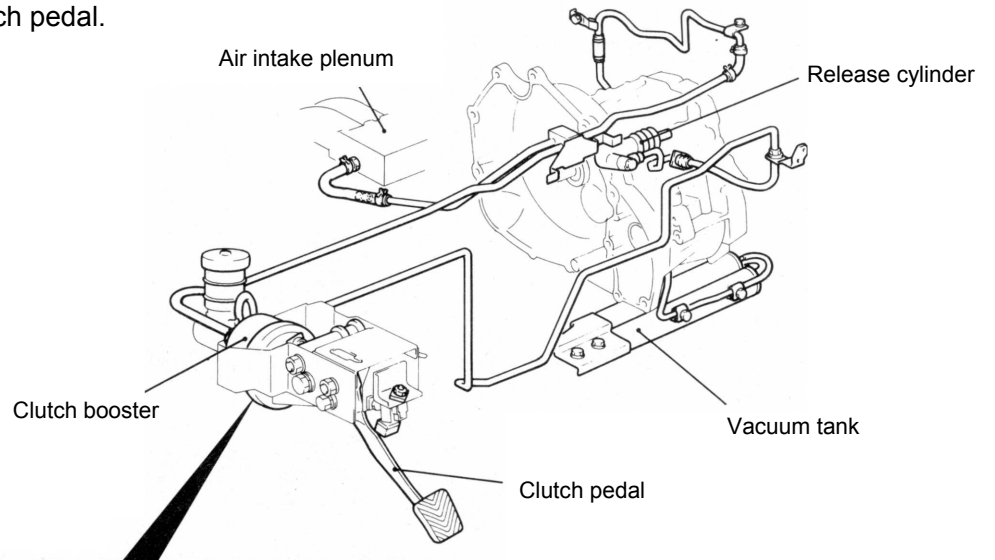

08F0020

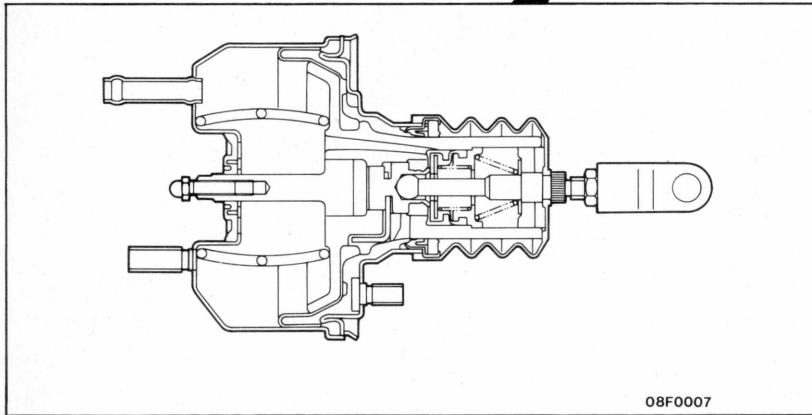

08F0007

CHASSIS

Steering

- A compact lightweight integral type rack and pinion type power steering for outstanding steering response.
- Tilt steering construction for ideal steering position.
- SRS built into the steering wheel to protect the driver.
- 4-wheel steering system (4WS) for improved stability in the medium and high speed range.

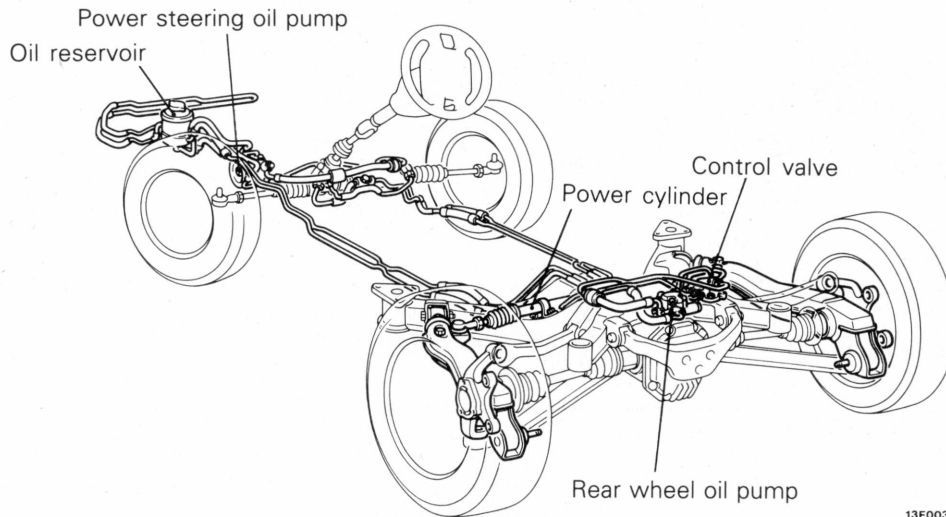

Front Suspension

- Very lightweight and rigid McPherson strut type independent suspension.
- Offset coil spring for comfortable ride.
- Anti-diving geometry for outstanding stability.
- Negative offset geometry for superior stability when braking.
- Electronic control suspension (ECS) for both driving stability and riding comfort.
- Liquid filled bushing to reduce noise.

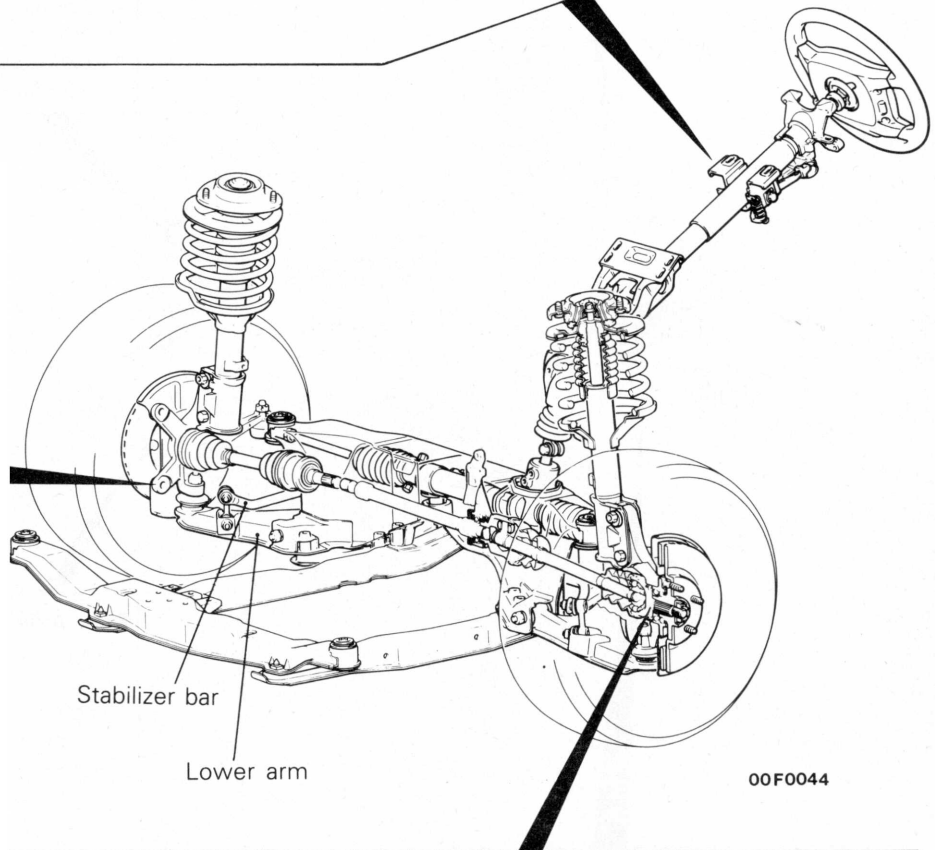

Front Axle

- BJ-TJ type constant velocity joint with high transmission efficiency and minimum vibration and noise.
- Isometric drive shaft for reduced vibration, noise and torque steer.
- A unit ball bearing consisting of the hub and bearing for good serviceability and little rolling resistance.

Brake

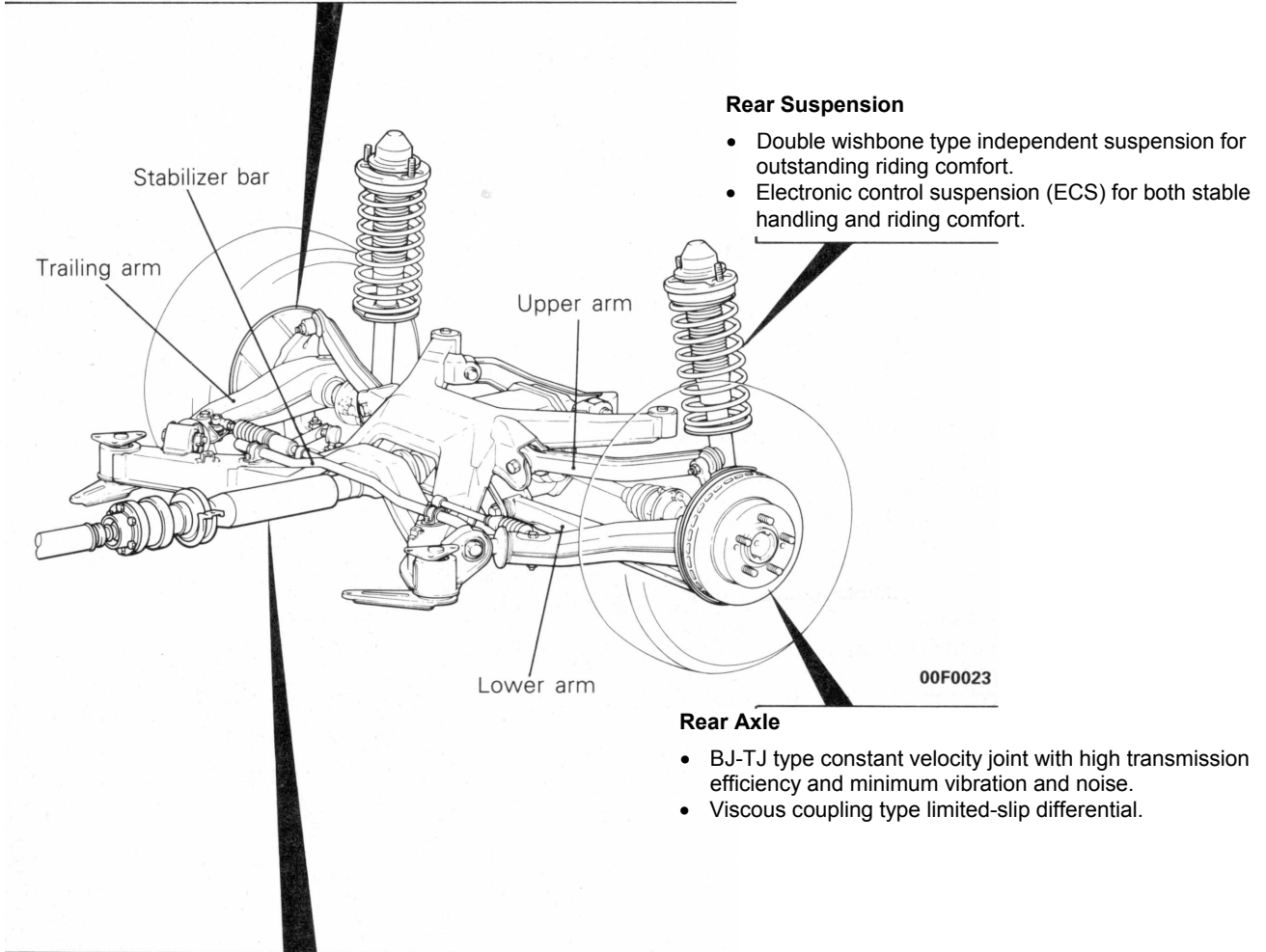
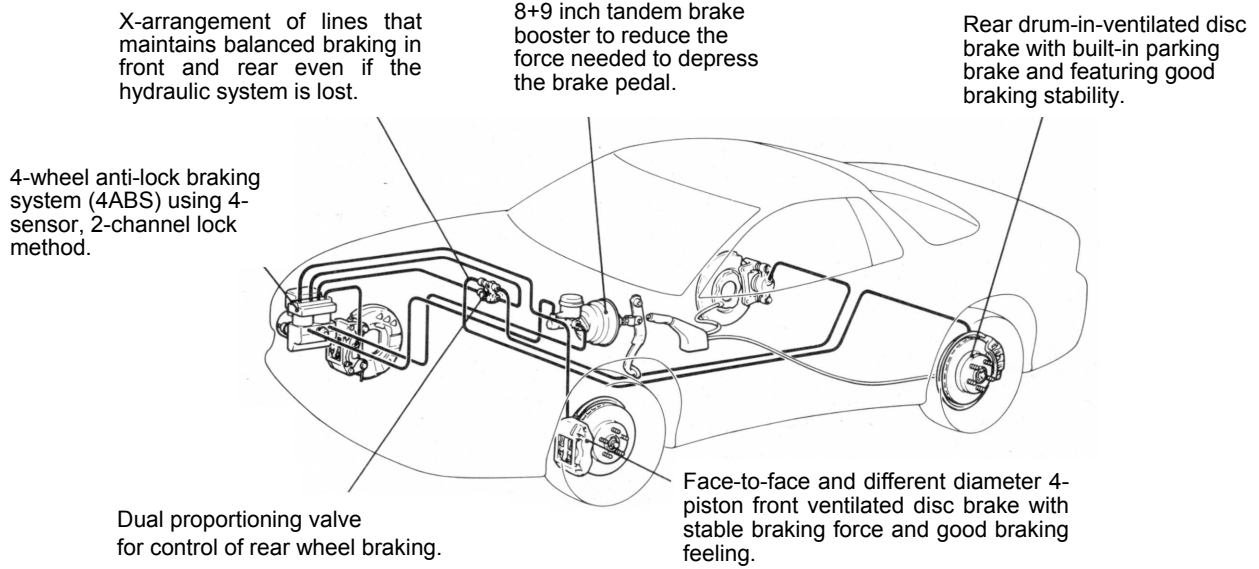

Propeller Shaft

- 3-section 4-joint type propeller shaft with two center bearings.
- Robro joint to absorb lengthwise and angular change and prevent transmission of vibrations.
- Anti-vibration type propeller shaft (rear propeller shaft) to reduce vibration and noise from the drive train.

GENERAL - Technical Features

SUPPLEMENTAL RESTRAINT SYSTEM (SRS)

SRS is a system that works with the seat belt and is designed as auxiliary equipment to the seat belt. It only functions to protect the upper body of the driver

when a shock that is over the design value (deceleration G) is added to the entire vehicle from the front.

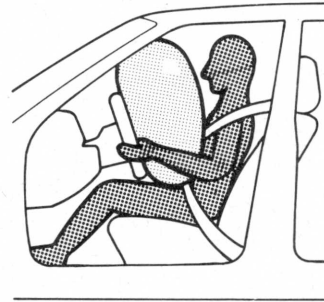
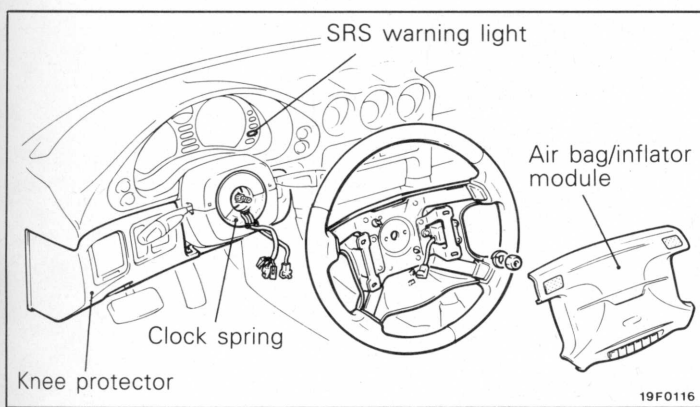

13R0707

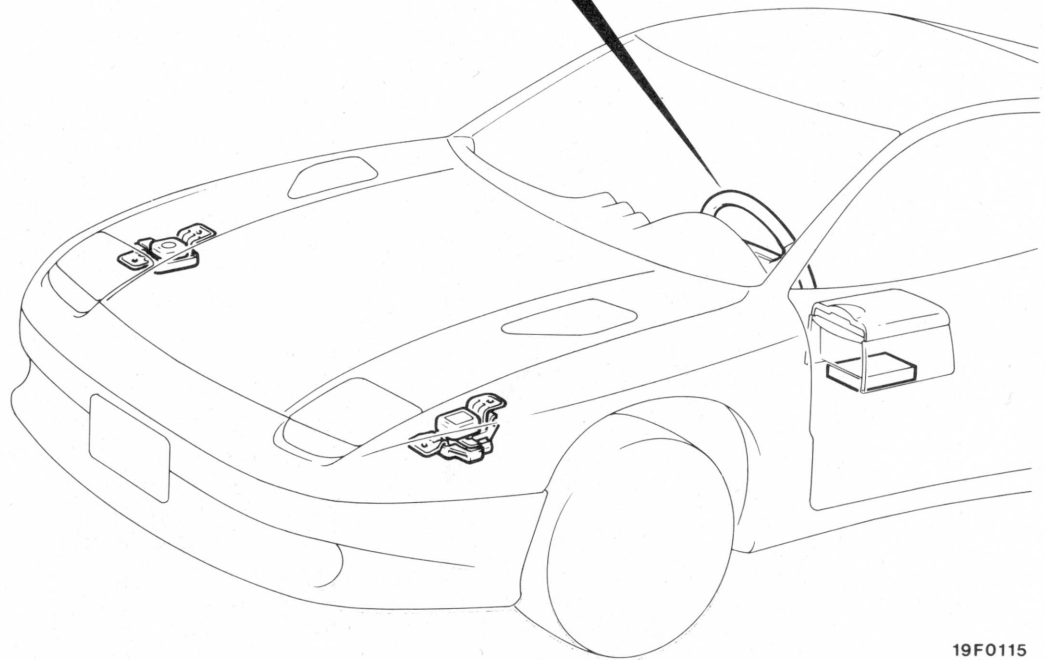

19F0115

SMALL AMOUNT REFRIGERANT SYSTEM (AIR CONDITIONER)

In order to protect the ozone layer, the small amount refrigerant system was developed by improving the structural parts of the air conditioner, making it more compact, etc. in order to reduce as much as possible

the amount of chloro-fluoro carbon used as the refrigerant in automobile air conditioners.

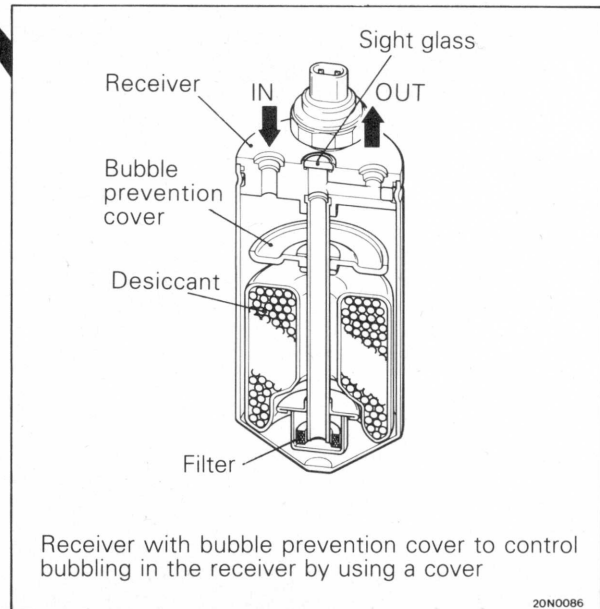
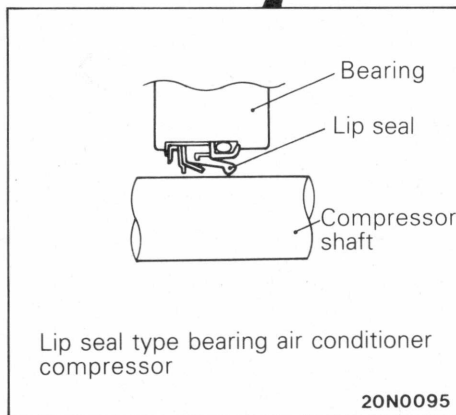
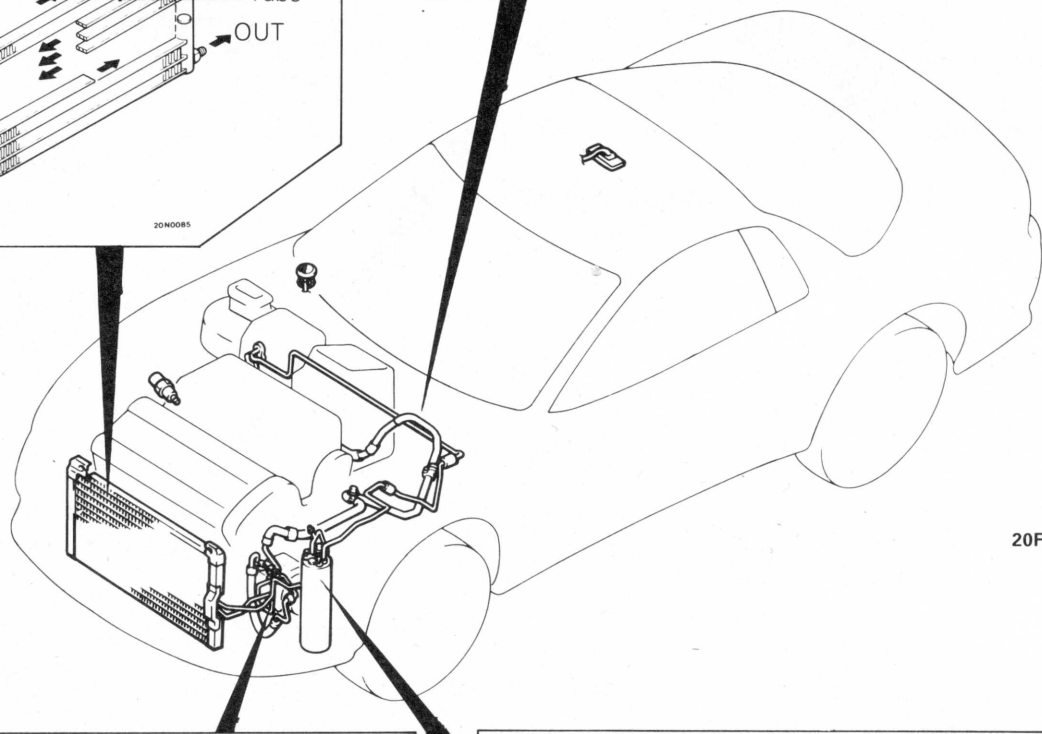
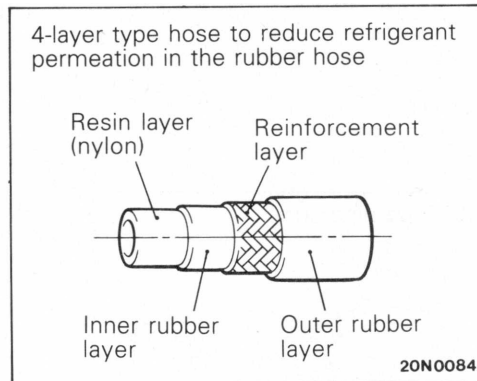
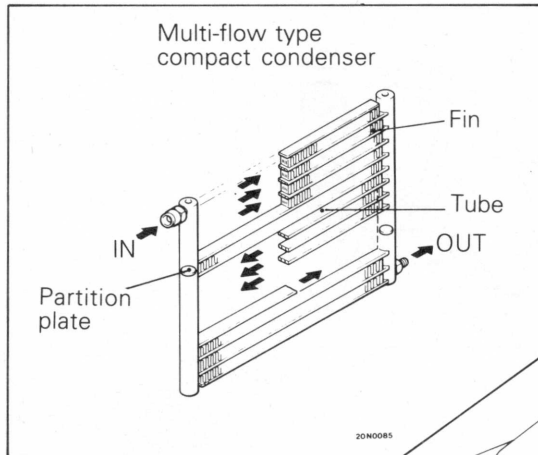

THEFT-ALARM SYSTEM

To make the vehicle theftproof, this system is designed to operate the horn intermittently for 30 seconds when the locked door, hood or tailgate has

been forced open without using a key. Furthermore, the starter circuit is interrupted so that the engine may not be operated.

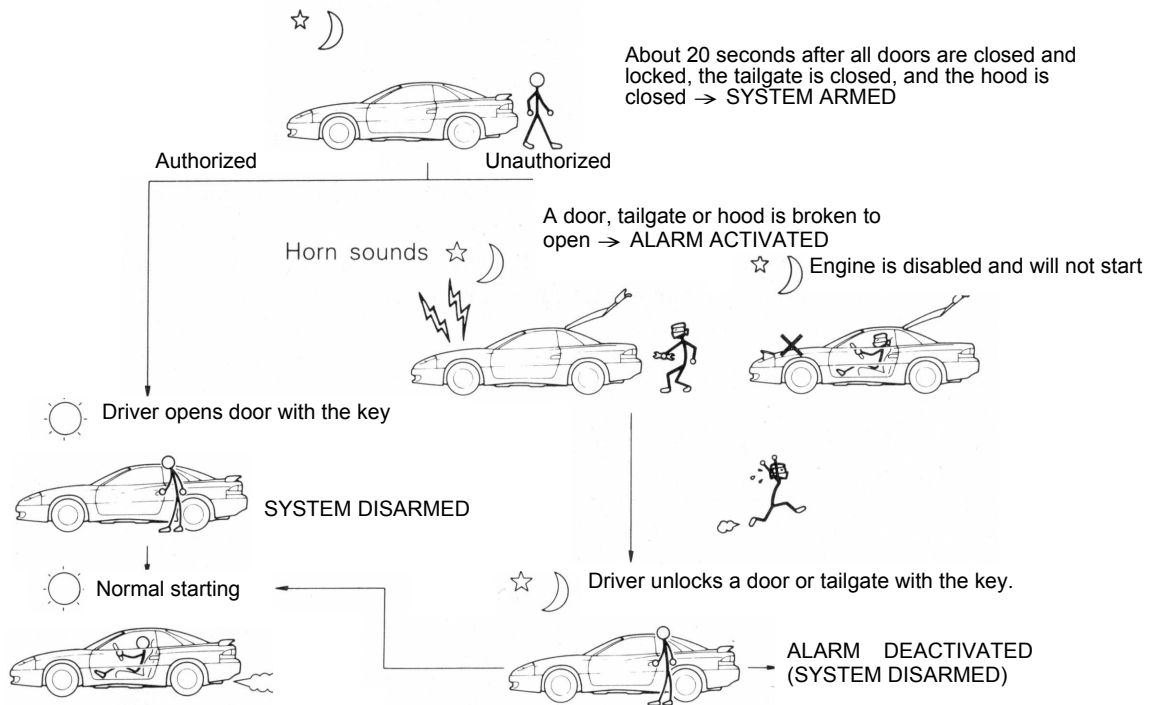

SERVICEABILITY

A series of investigations from a variety of angles are carried out starting from the planning and design stages, to produce a vehicle with complete diagnosis functions

and a reduced need for maintenance, with improvements in reliability and durability.

Items of improved serviceability

- Adoption of hydraulic-type lash adjusters which make valve clearance adjustment unnecessary
- Adoption of an auto tensioner which makes timing belt tension adjustment unnecessary
- Adoption of a distributorless 3 coil ignition system
- Adoption of a camber adjustment mechanism in the front suspension
- Adoption of an alignment adjustment mechanism in the rear suspension
- Adoption of an outer disc method which makes brake disc removal and installation simple
- Adoption of audible pad wear indicators in the brakes
- Adoption of a drum in parking disc type brake to improve workability for the rear brakes
- Adjustment of gap between wheel speed sensors and rotors in 4ABS
- Colour-coding of service connectors (for ignition timing adjustment, fuel pump inspection and engine speed inspection) to distinguish them from other connectors and make them easier to find
- Expansion and full realization of the self-diagnosis system
- Improvement in reliability due to harness junction connectors
- Centralization of relays
- Receiver piping connection has been made into a flange fitting and the end of the piping section has been flared to prevent falling off of O-rings

VEHICLE IDENTIFICATION**MODEL****VEHICLES FOR EUROPE**

Model code	Engine model	Transmission model	Fuel supply system
Z16AMNGFL6	6G72 [2,972 cm ³ (181.4 cu. in.)]	W5MG1	MPI
Z16AMNGFR6			

VEHICLES FOR GENERAL EXPORT

Model code	Engine model	Transmission model	Fuel supply system
Z16AMNGFL	6G72 [2,972 cm ³ (181.4 cu. in.)]	W5MG1	MPI
Z16AMNGFR			

VEHICLES FOR GCC

Model code	Engine model	Transmission model	Fuel supply system
Z16AMNGFLW	6G72 [2,972 cm ³ (181.4 cu. in.)]	W5MG1	MPI

VEHICLES FOR AUSTRALIA

Model code	Engine model	Transmission model	Fuel supply system
Z16AMNGFR8	6G72 [2,972 cm ³ (181.4 cu. in.)]	W5MG1	MPI

MODEL CODE**Z 1 6 A M N G F L 6**

1 2 3 4 5 6 7 8 9

- | | |
|---|---|
| <ol style="list-style-type: none"> 1. Development order (& Drive train)
Z1 - MITSUBISHI 3000GT
(Full time 4WD) 2. Engine type
6 - 2,972 cc (181.4 cu. in.), petrol 3. Sort
A - Passenger car 4. Body style
M - 2-door hatchback 5. Transmission type
N - 5-speed manual transmission 6. Trim code | <ol style="list-style-type: none"> 7. Specified engine feature
F - Turbocharger (with intercooler) 8. Steering wheel location
L - Left hand
R - Right hand 9. Destination
6 - For Europe
8 - For Australia
W - For GCC
None - For General Export |
|---|---|

MAJOR SPECIFICATIONS

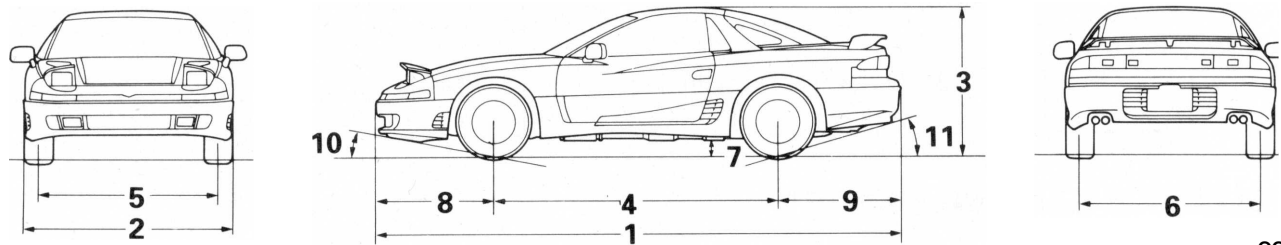

OOF0015

Items		Z16AMNGFL6 , Z16AMNGFR6	Z16AMNGFL Z16AMNGFR	Z16AMNGFLW Z16AMNGFR8
Dimensions	mm(in.)			
Overall length	1	4,560 (179.5)		
Overall width	2	1,840 (72.4)		
Overall height (unladen)	3	1,285 (50.6)		
Wheelbase	4	2,470 (97.2)		
Track-Front	5	1,560 (61.4)		
Track-Rear	6	1,580 (62.2)		
Ground clearance (unladen)	7	145 (5.7)		
Overhang-Front	8	1,030 (40.6)		
Overhang-Rear	9	1,060 (41.7)		
Angle of approach degrees	10	11.2°		
Angle of departure degrees	11	17.3°		
Weight	kg (lbs.)			
Kerb weight		1,740 (3,836)		
Gross vehicle weight		2,120 (4,674)		
Max. axle weight				
Front		1,150 (2,535)		
Rear		1,020 (2,249)		
Seating capacity		4		
Engine				
Model		6G72		
Total displacement	cm ³ (cu.in)	2,972 (181.4)		
Transmission				
Model		W5MG1		
Type		5-speed manual		

ENGINE

CONTENTS -

GENERAL INFORMATION	2	CONTROL SYSTEM	14
Specifications	2	System Block Diagram	15
Engine Sectional View	2	Sensors	16
BASE ENGINE	4	Actuators	18
Oil Jet	4	Fuel Injection Control	19
Main Bearing Cap	4	Idle Speed Control (ISC)	20
Crank Angle Sensor and		Mechanical Dashpot	21
Cam Position Sensor	5	Ignition Timing and	
Crank shaft	5	On Time Control	22
Exhaust Valve	5	Power Supply and	
MOUNTING	6	Fuel Pump Control	23
LUBRICATION SYSTEM	7	Fuel Pump Discharge	
COOLING SYSTEM	8	Volume Control	24
Specifications	8	Turbo Meter Control	24
INTAKE/EXHAUST SYSTEM	10	Turbo Pressure /Control	25
Twin-turbochargers and Twin-intercoolers	10	Fuel Pressure Control	26
Turbo Pressure Control	10	Air Flow Sensor (AFS)	
Exhaust Pipe	11	Filter Reset Control	26
FUEL SYSTEM	12	Self Diagnosis System	27
Fuel-pressure Control Valve	12	EMISSION CONTROL SYSTEM	30
Fuel Tank	12	CRUISE CONTROL SYSTEM	32

GENERAL INFORMATION

The engine is a V-type 6-cylinder (bank angle 60°) 2,972 cm³ (181.4 cu.in.) DOHC 24 valve design and is basically the same as the engine equipped in the SIGMA. However, twin turbochargers and twin inter-coolers have been installed to provide even higher output and higher performance.

NOTE

For details of the basic engine structure, refer to the previously-issued '91 SIGMA Technical Information Manual. (Pub. No. PYGE9008).

SPECIFICATIONS

Items		Specifications	
Total displacement	cm ³ (cu. in.)	2,972 (181.4)	
Arrangement and number of cylinders		V type, 6 cylinders	
Combustion chamber type		Pentroof type	
Number of intake and exhaust valve (per cylinder)		2 each	
Valve mechanism		OHV, DOHC (per bank)	
Bore x stroke	mm (in.)	91.1 x 76.0 (3.59 x 2.99)	
Compression ratio		8.0	
Maximum output	PS/rpm	285/6,000	
Maximum torque	kgm/rpm	41.5/3000	
Valve timing	Intake	Opened	16° BTDC
		Closed	55° ABDC
	Exhaust	Opened	50° BBDC
		Closed	17° ATDC
Fuel supply system		Electronic controlled multi-point fuel injection	
Ignition system	Power distribution method	Electronic controlled 3-coil type	
	Ignition timing control method	Electronic controlled type	

ENGINE SECTIONAL VIEW

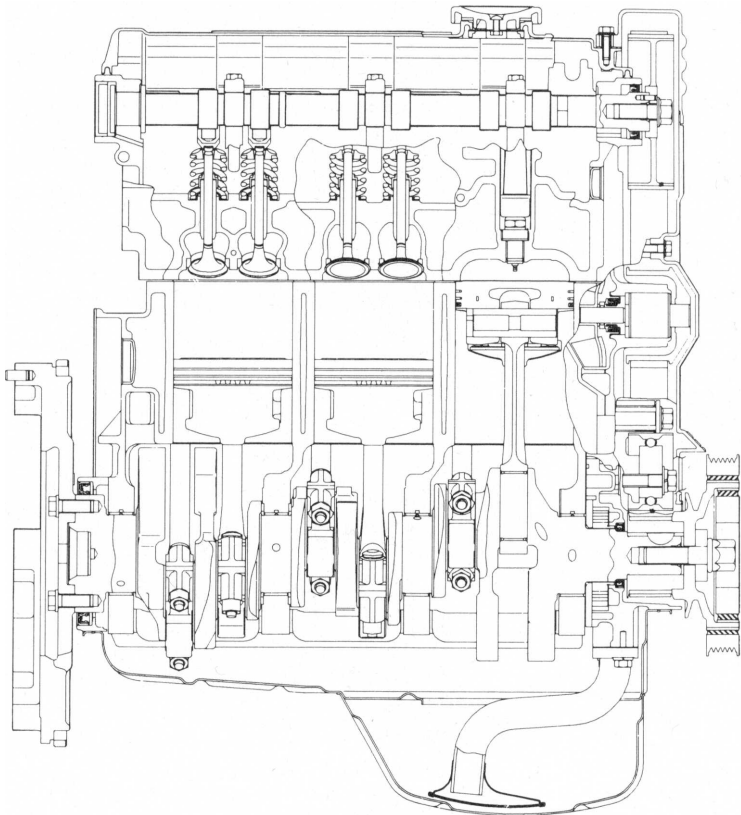

7EN0477

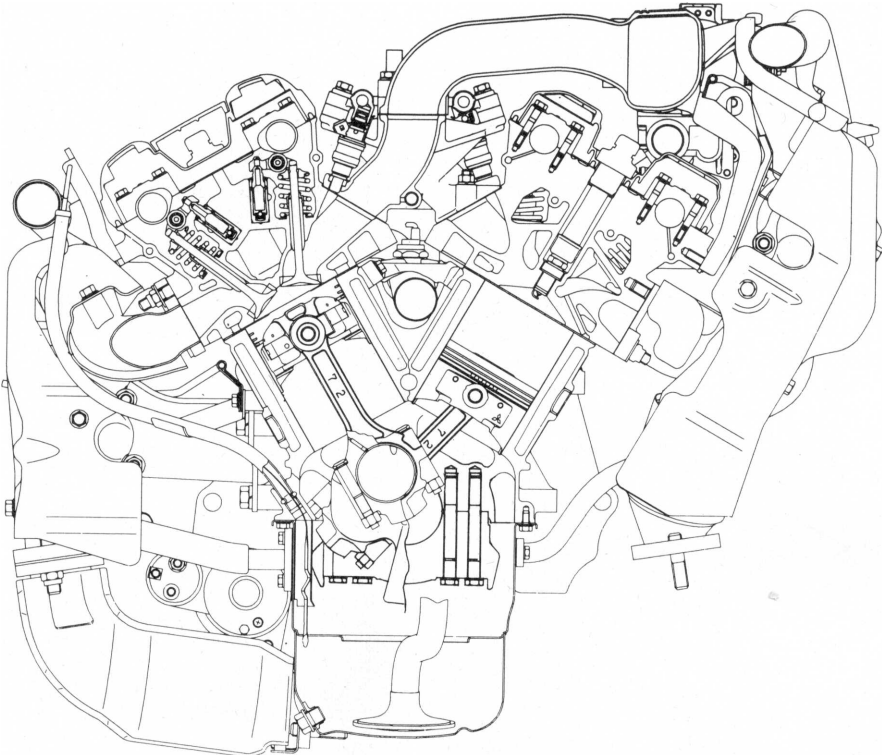

7EN0478

BASE ENGINE

OIL JET

There is an oil jet for cooling the pistons.

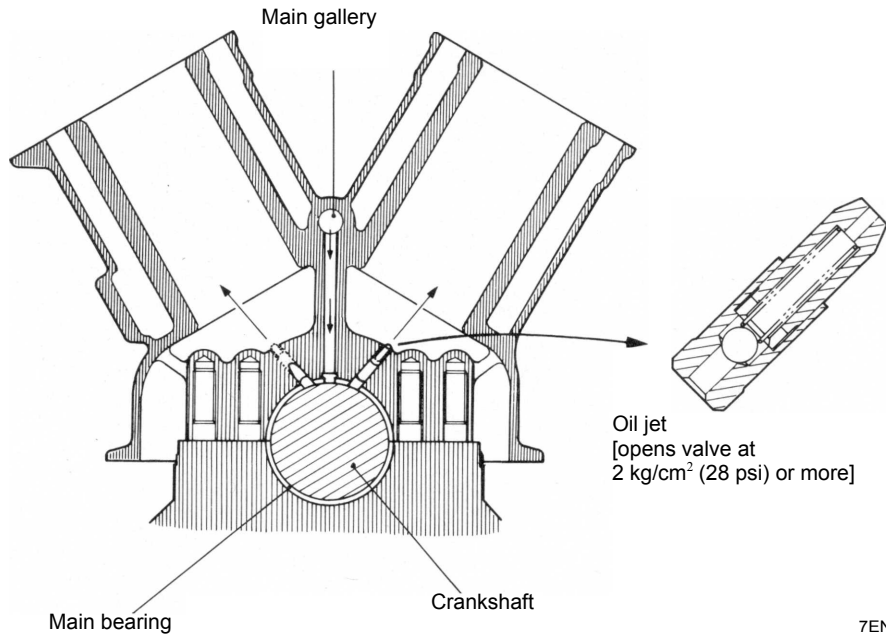

7EN0479

MAIN BEARING CAP

The main bearing caps are of a conventional integrated type with beam. By tightening each of the bearing sections with 4 bolts, rigidity has been improved and

vibration from the main drive section has been reduced.

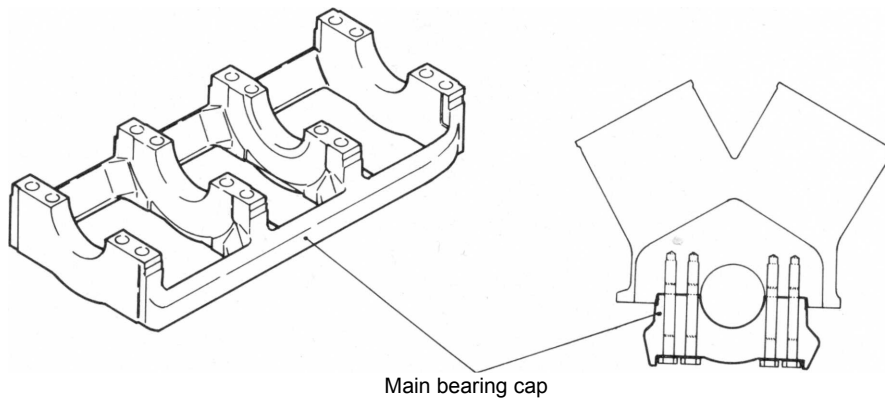

7EN0480

CRANK ANGLE SENSOR AND CAM POSITION SENSOR

An ultra-small crank angle sensor and cam position sensor have been positioned inside the crankshaft sprocket and camshaft sprocket respectively to realize

a large space saving and to provide improved crank angle detection precision.

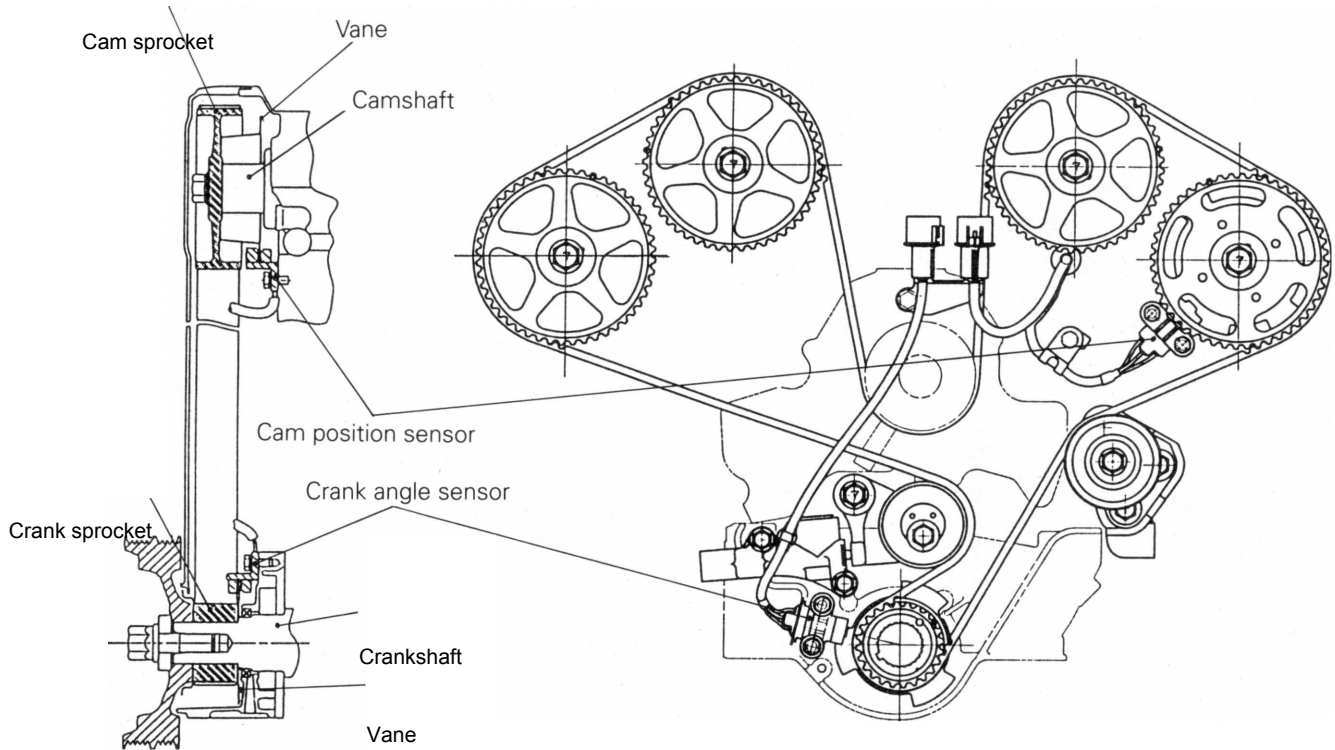

7EN0481

CRANKSHAFT

A steel crankshaft has been adopted in order to cope with the increased engine output and to provide

reduced noise and reduced vibration.

EXHAUST VALVE (VEHICLES FOR EUROPE ONLY)

Lightweight sodium-filled vacuum valves have been developed for use as the exhaust valve to improve valve follow in high-speed ranges. At the same time, the cooling performance of the exhaust valve has

been improved, and improvements have been realized in anti-knock characteristics and fuel consumption efficiency at high speeds.

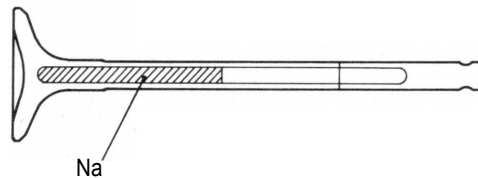

7EN0482

Caution on handling the metallic sodium-filled exhaust valve.

Because metallic sodium reacts violently when it comes into contact with water or moisture to generate hydrogen gas, there is a danger that explosion or fire may occur, so it should be treated with caution.

For specific details, refer to the Engine Workshop Manual.)

MOUNTING

The engine mounts use a principal axis inertia support system. This support method on the principal axis inertia is a structure that supports the top of the engine and top of the transmission to effectively control engine vibration. A dynamic damper is provided on top of the engine mount to cut out high-frequency noise.

Roll stoppers (front and rear) are installed on the crossmember that is elastically supported on the body to reduce transmission of engine vibration to the body. The various mounts have the following features

- Each insulator has a hole to effectively absorb small and large vibrations.

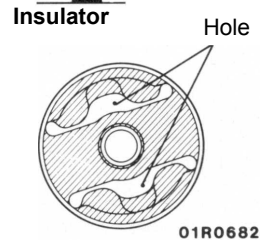
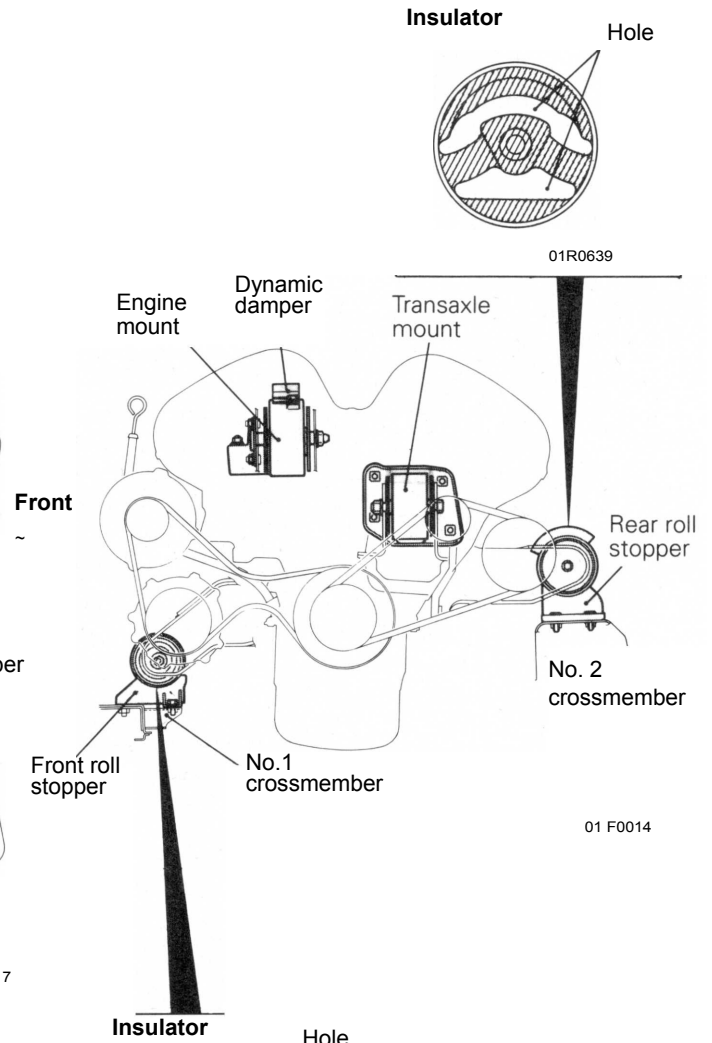
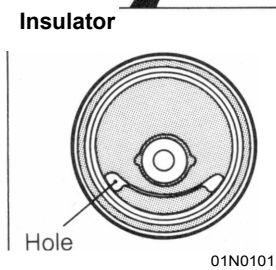
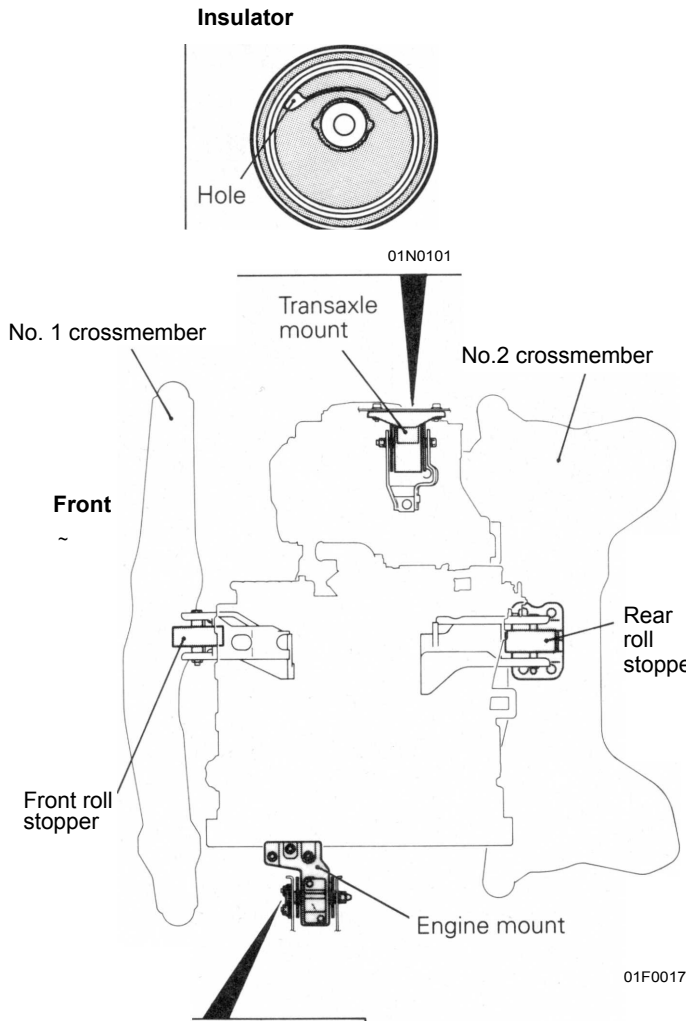

LUBRICATION SYSTEM

An oil pressure gauge unit has been installed in all models. In addition, an oil level sensor has been

equipped in the oil pan (Vehicles for Europe).

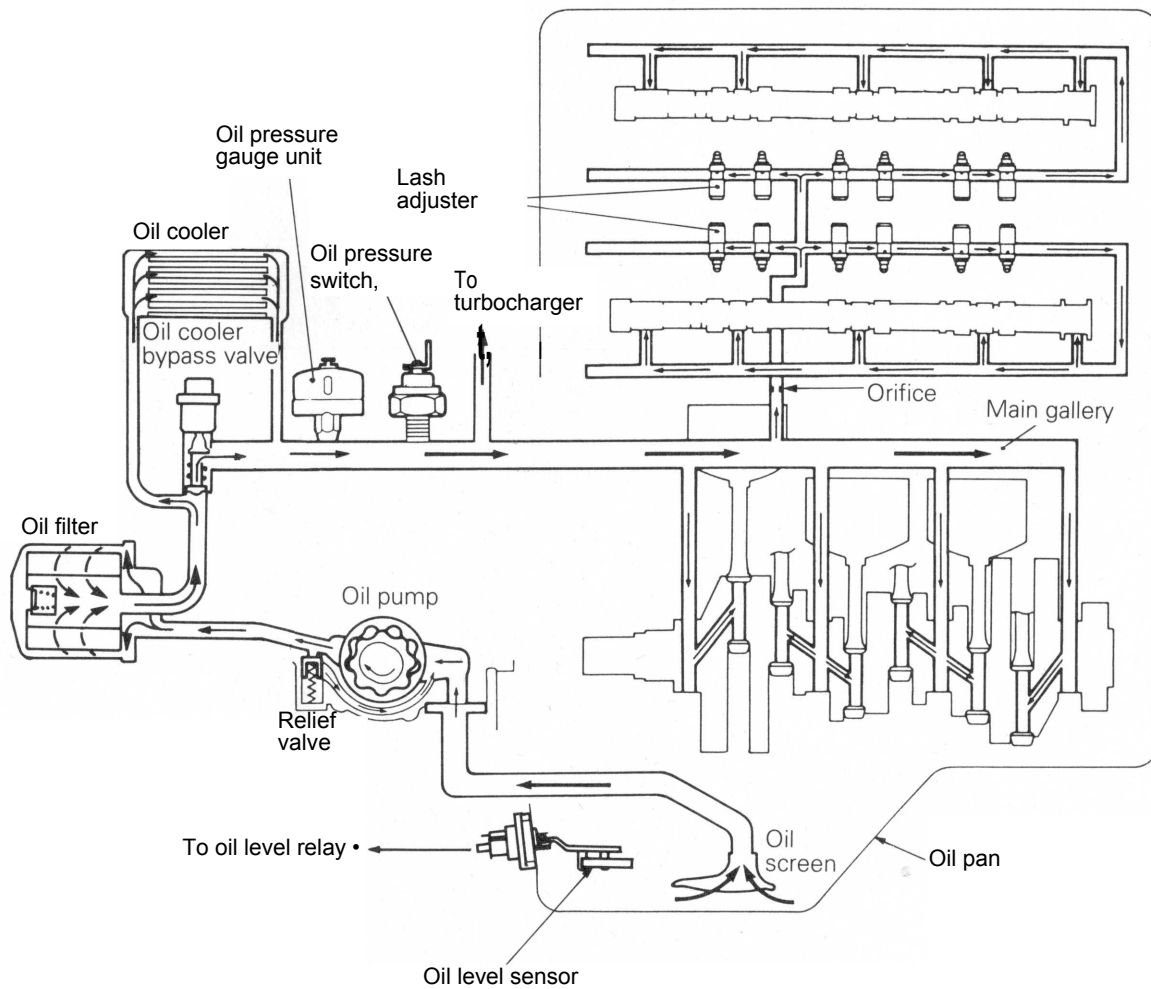
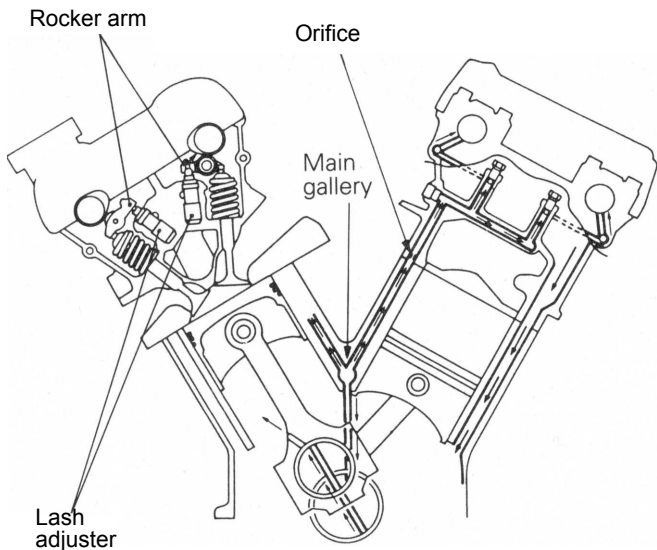

COOLING SYSTEM

The cooling system uses a water cooling pressure control circulation system and it has the following features.

- The cooling (radiator) fan uses a motor driven system. The fan is driven by the motor only when needed to efficiently control the cooling water temperature and reduce engine output loss .
- The cooling fan is a full shroud type for improved cooling performance.
- The two step control system is used for the motor driven cooling fan and condenser fan for less fan noise, reduced vehicle vibration and improved cooling when the engine is idling. (Refer to GROUP 7 - Condenser Fan and Radiator Fan Control for fan speed operation mode.)

SPECIFICATIONS

Items	Specifications
Cooling fan Type	Motor driven system
Water pump Type Drive method	Centrifugal type impeller Timing belt
Thermostat Type Open valve temperature °C (°F)	Wax type 76.5 (170)
Radiator Coolant capacity (including that in condenser tank) dm ³ (U.S. qts., Imp. qts.) Condenser tank capacity dm ³ (U.S. qts., Imp. qts.) Full Low Type	8.0 (8.5, 7.0) 0.65 (0.69, 0.57) 0.25 (0.25, 0.22) Corrugated type

Items	Specifications
Radiator fan motor Maker Type Rated load torque Speed Current	Nippon Denso Direct flow ferrite type Nm (kgm, ft.lbs.) 53 (5.3, 39) rpm 2,080 ± 250 A 13.6 ± 1
Thermo sensor for radiator fan Operating temperature OFF --+ ON ON --+ OFF	°C (°F) 81-89 (178-192) 77 (171) or more
Thermo sensor for condenser fan Operating temperature OFF --+ ON ON --+ OFF	°C (°F) 91-99 (196-210) 87 (189) or more

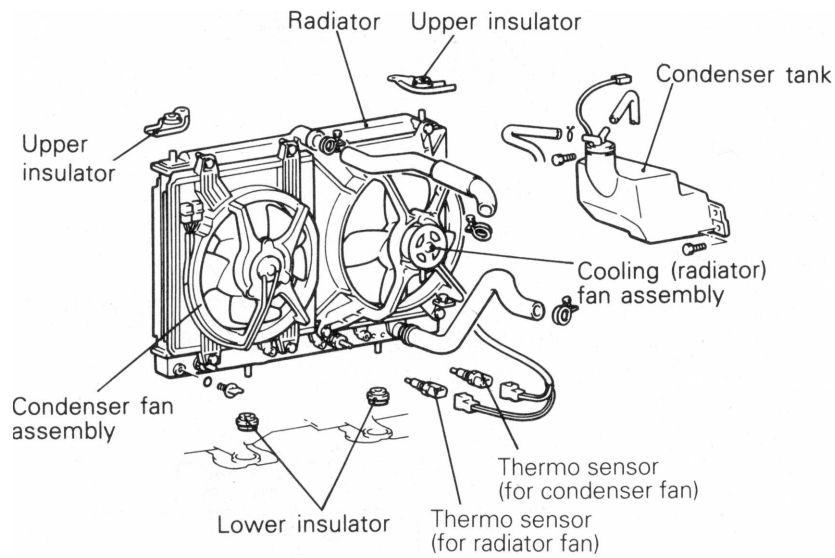

04 F0003

INTAKE/EXHAUST SYSTEM

TWIN TURBOCHARGERS AND TWIN INTERCOOLERS

Compact, lightweight, turbochargers with outstanding response are used in each bank, front and rear, for the best turbo feeling at all speeds, from low to high. The turbocharger is a water-cooled TD04 type with waste gate valve. The intercoolers are very efficient and each

one is arranged on the front and rear banks just like the turbocharger. With the combined action of the turbocharger and intercooler, powerful acceleration is possible from any speed.

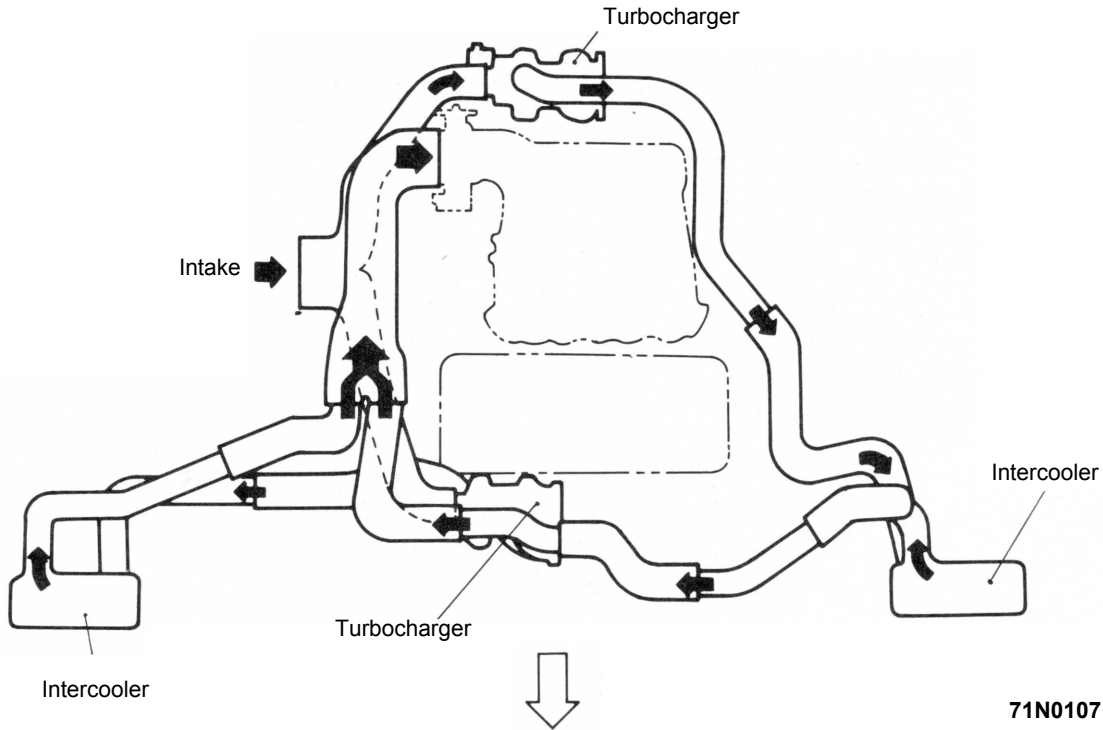

TURBO PRESSURE CONTROL

The waste gate operating pressure is controlled to make possible flat turbo pressure characteristics

over the entire rpm range and to provide a linear acceleration feeling.

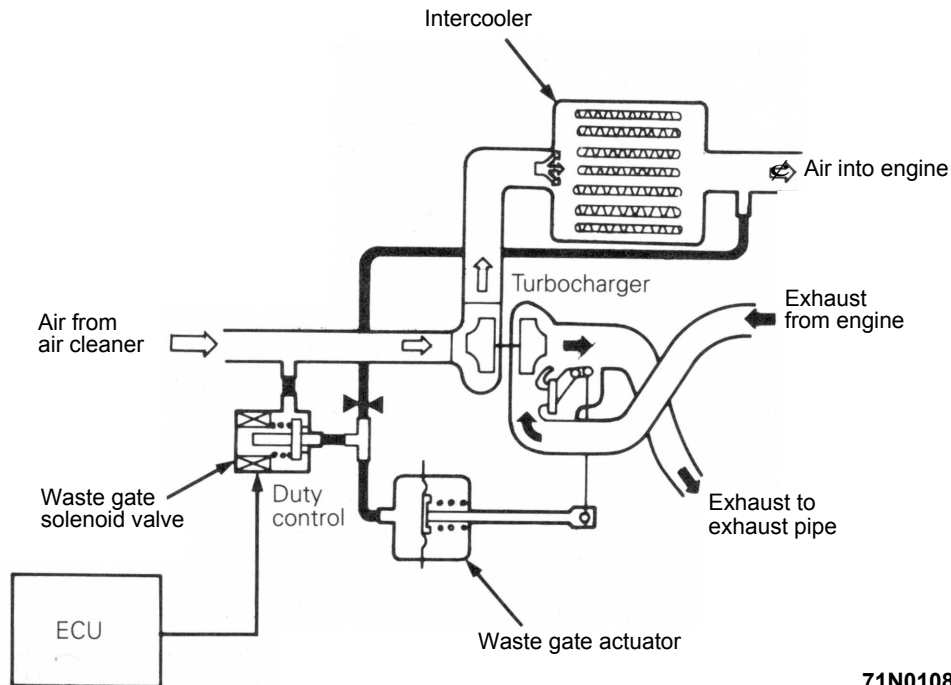

EXHAUST PIPE

The exhaust pipe is divided into three sections, front pipe, centre pipe and main muffler. It is installed on the body via a rubber hanger to reduce transmission of vibrations from the exhaust system to the body. A dual

pipe is used for the front pipe to improve exhaust efficiency, and a dual tail pipe with muffler cutter is used as the main muffler.

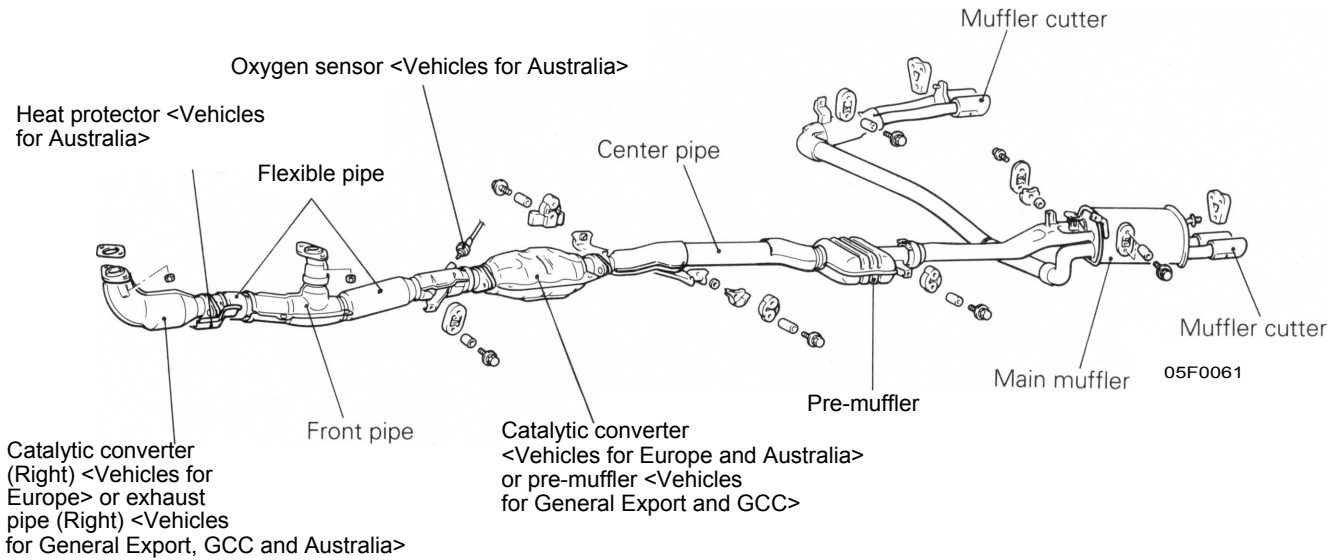

FUEL SYSTEM

The fuel system consists of electromagnetic fuel injectors, delivery valves, a fuel pressure regulator for regulating fuel pressure, and an electromagnetic fuel pump which operates at high pressure. It is basically the same as the fuel system in the conventional 6G7 engine, but the fuel pressure is controlled to 3.0 kg/cm². In addition, in order to verify the idling stability immediately after re-starting the engine at high temperatures, a fuel pressure control solenoid valve which is the same as the one fitted in the convention-

al 4G63 engine.

The fuel tank is located under the luggage compartment floor and the fuel filters are in the fuel tank and in the engine compartment to filter the fuel. For better serviceability, there is a terminal for the fuel pump drive in the engine compartment and a service hole in the luggage compartment; the pump and gauge assembly can be removed without removing the fuel tank.

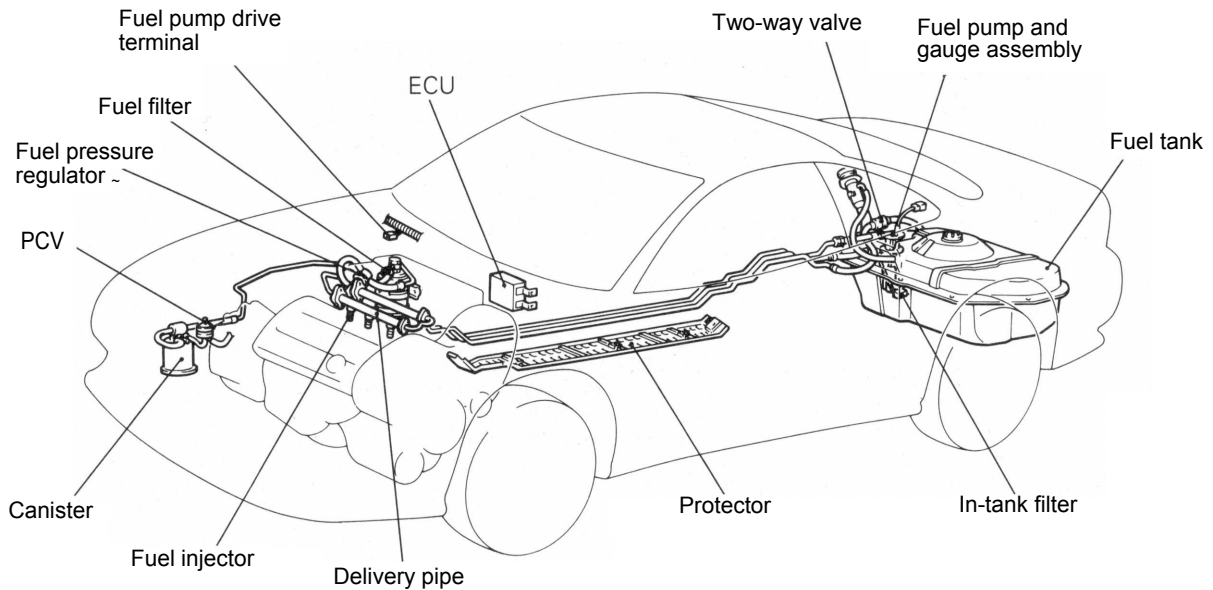

03 F0009

FUEL-PRESSURE CONTROL VALVE

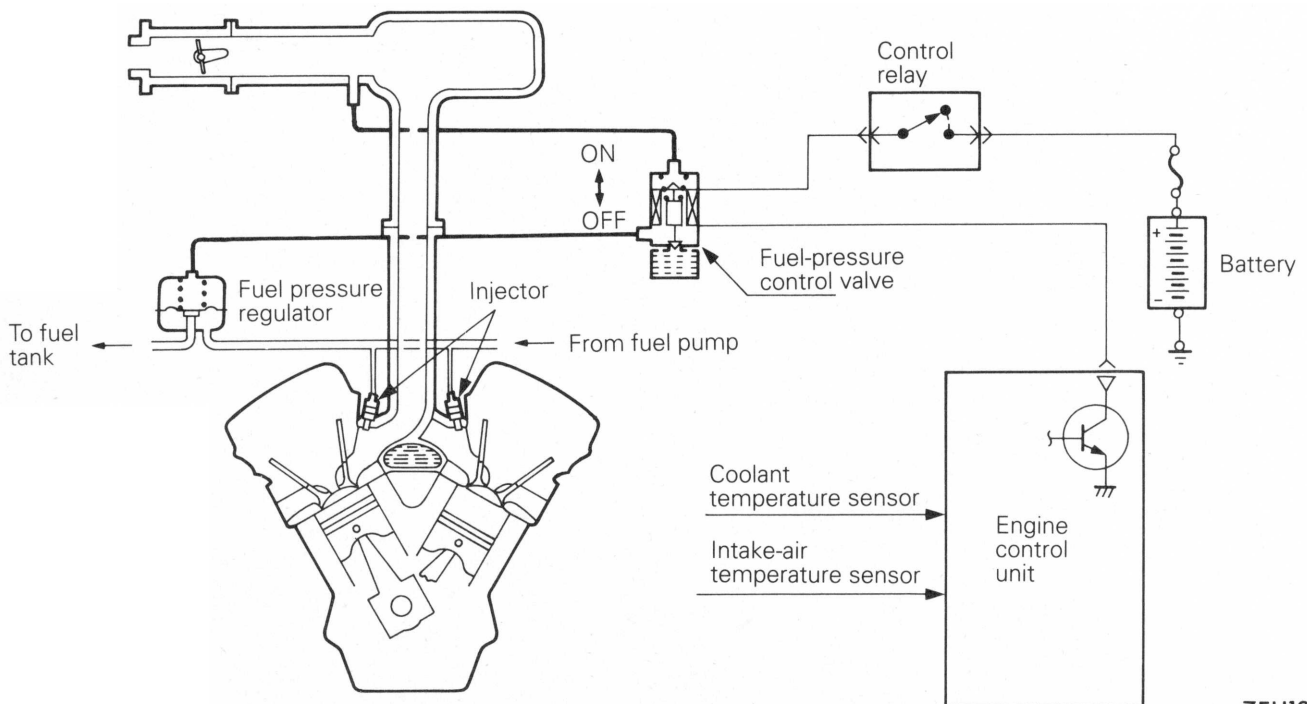

7FU1339

Normally, the negative pressure in the intake manifold acts upon the fuel pressure regulator to maintain the fuel pressure at a constant level with regard to the pressure inside the intake manifold, causing the amount of fuel injected to be controlled in proportion to the injector drive time. However, if the engine is started while the engine coolant temperature and the intake air temperature are high, the engine control unit makes

current flow to the fuel pressure control valve to activate the fuel pressure regulator by means of atmospheric pressure.

Because of this, the generation of fuel vapour due to the high fuel pressure and high temperature is avoided, and the idling stability immediately after re-starting the engine at high temperatures is maintained.

FUEL TANK

The electric fuel pump, in-tank filter and fuel gauge unit are built into the fuel tank.

The fuel tank has the following features.

- Baffle plates are placed inside the fuel tank to prevent abnormal noise due to fuel movement.
- There is a reseve cup inside the fuel tank for

smooth supply of fuel even when there is little fuel remaining.

- A pump and gauge assembly that combines the gauge unit and fuel pump in one unit is adopted.
- A drain plug is standard-equipped on all models.

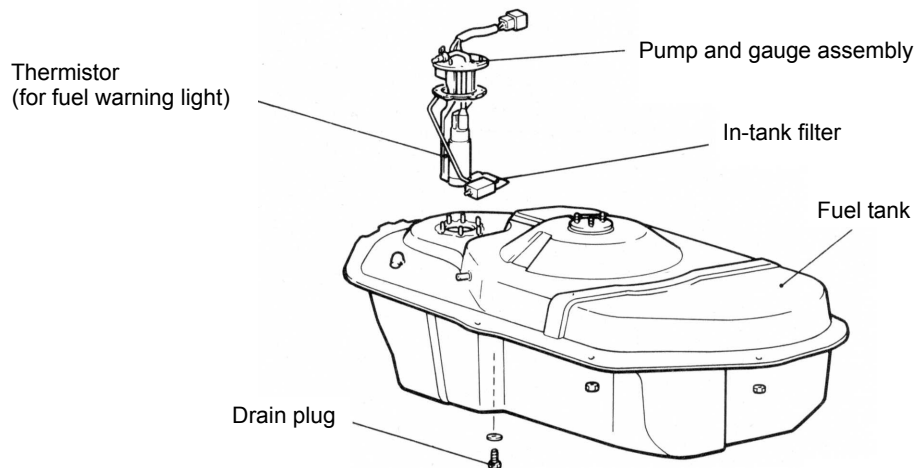

03F0008

CONTROL SYSTEM

The control system used is basically the same as that in the conventional 6G72 engine in the SIGMA. However, some parts differ as shown below.

Main items changed or added	Notes
Control relay and fuel pump power circuit have been changed.	<ul style="list-style-type: none"> ▪ Simplified power circuit ▪ Basically the same as the 4G9-DOHC engine
Crank angle sensor mounting position has been changed. (Crank angle previously detected from the camshaft is now detected directly from the crankshaft.)	<ul style="list-style-type: none"> ▪ Improvement in crank angle sensor precision ▪ Improvement in ignition timing control precision
Adoption of fuel pump relay No.2 and fuel pump resistor	Improvement in fuel pump reliability
Fuel pressure control has been added. (Refer to P.1-26.)	Control additions to correspond to adoption of a turbocharger
Turbo pressure control has been added.	
Turbo meter control has been added.	
Adoption of a twin oxygen sensor system <Vehicles for Europe, Hong Kong and Singapore>	Reduction in exhaust gas levels

SYSTEM BLOCK DIAGRAM

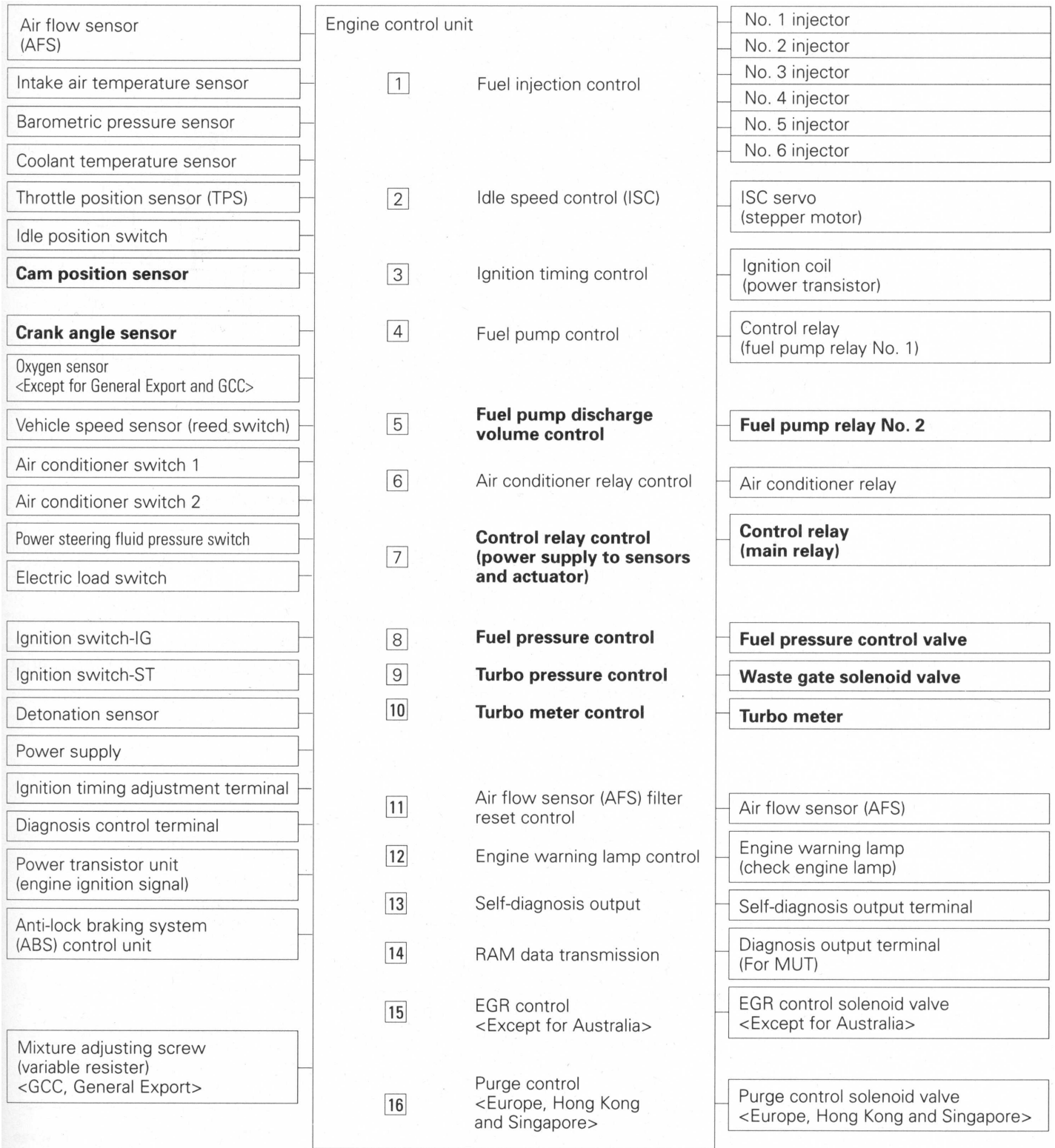

Remarks

The changed or added items with respect to the conventional engine are shown in bold letters.

SENSORS

Cam position sensor and crank angle sensor

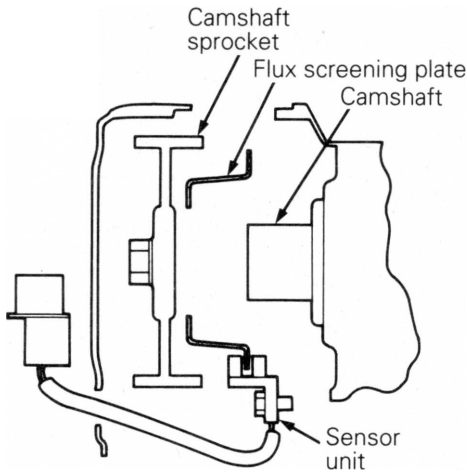

6AF0009

Cam position sensor

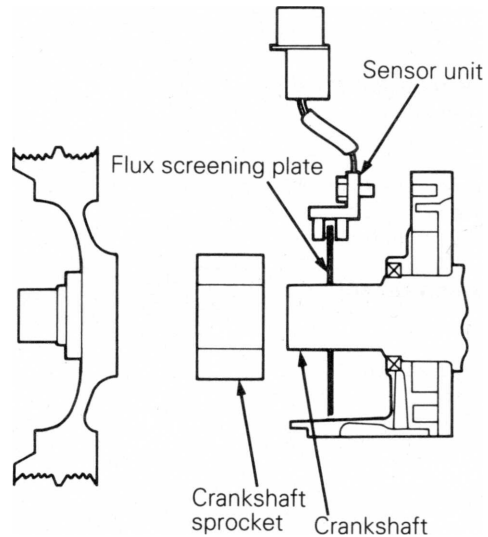

6AF0002

Crank angle sensor

The cam position sensor consists of a flux screening plate fixed to the crankshaft sprocket on the rear bank exhaust side and a sensor unit fixed to the cylinder head. The crank angle sensor consists of a flux screening plate fixed to the crankshaft sprocket and a sensor unit fixed to the engine oil pump case. The cam position sensor and crank angle sensor convert the rotation of the camshaft and crankshaft into pulse sig-

nals as shown in the illustration below, and input these pulse signals to the engine control unit. Furthermore, these waveforms are the same as those for the conventional 6G7-DOHC engine, but the mounting precision of the crank angle sensor has been improved, making basic ignition timing adjustment unnecessary.

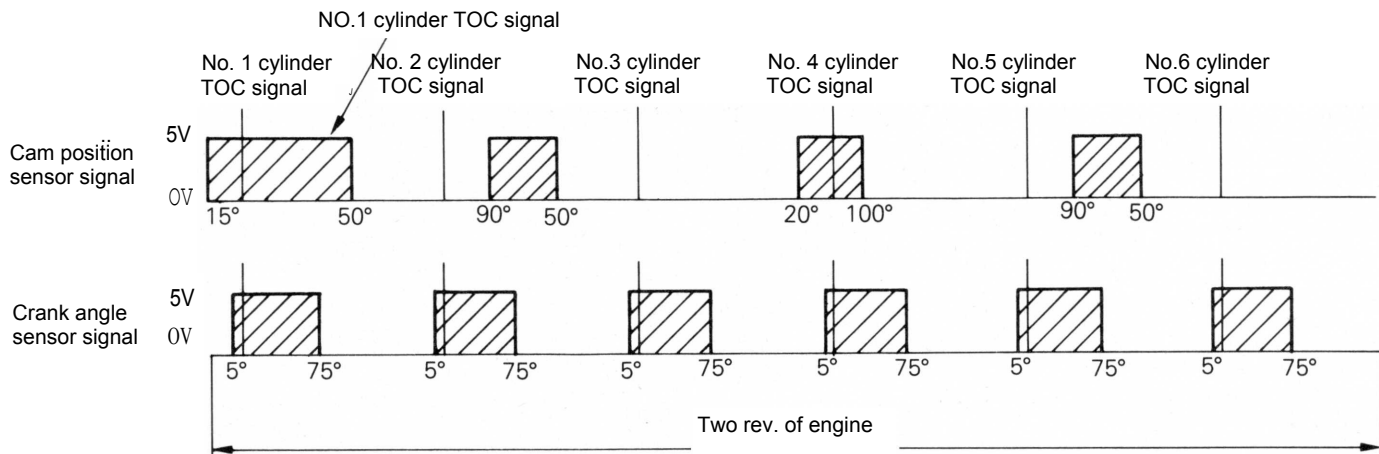

7FU0729

Flux screening plate for Cam position sensor

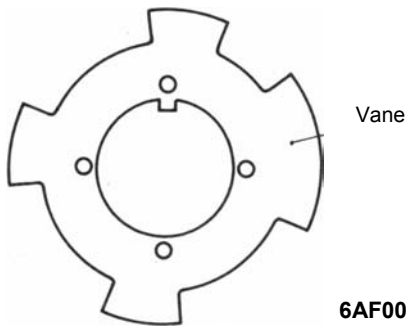

Flux screening plate for crank angle sensor

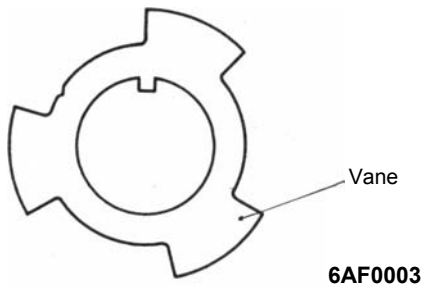

The shapes of the flux screening plates used in the cam position sensor and crank angle sensor are as shown in the illustration at left. Detection of the cam position and crank angle is the same as for the conventional 4G93-S0HC engine, where the magnetic flux passing through the Hall element inside the sensor unit is alternately screened and allowed through by the vanes on the flux screening plate.

TWIN OXYGEN SENSOR <Europe, Hong Kong and Singapore>

There are sub catalysts in both the front and rear banks in the engine.

In order to maintain the proper air/fuel ratio in both banks, there is an oxygen sensor for each one before the catalyst of both banks to enable feedback control of the air/fuel ratio for each bank separately. Each oxygen sensor is the same as the conventional oxygen sensor with heater.

ACTUATORS

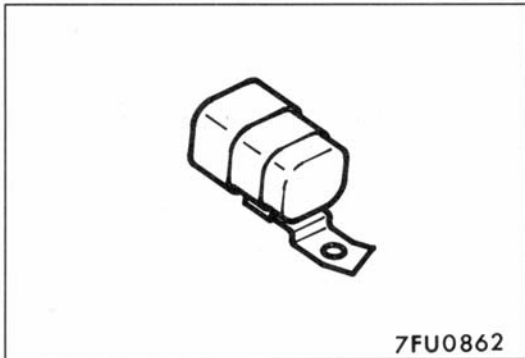
**FUEL PUMP RELAY NO.2**

Fuel pump relay No.2 is the relay that changes the supply voltage to the fuel pump in 2 steps, High/Low.

The engine control unit controls the amount of fuel discharged from the fuel pump by changing the supply voltage.

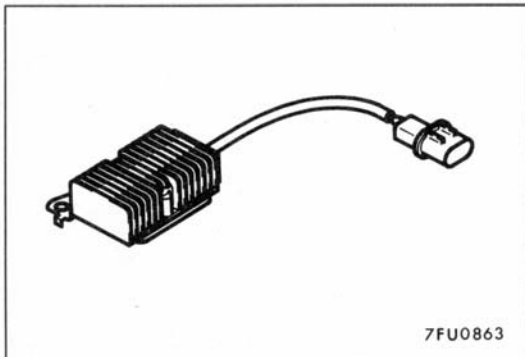
**FUEL PUMP RESISTOR**

The fuel pump resistor lowers the supply voltage to the fuel pump.

FUEL INJECTION CONTROL

The fuel injection control method is basically the same as that used in the conventional 6G72 engine.

SYSTEM CONFIGURATION DIAGRAM

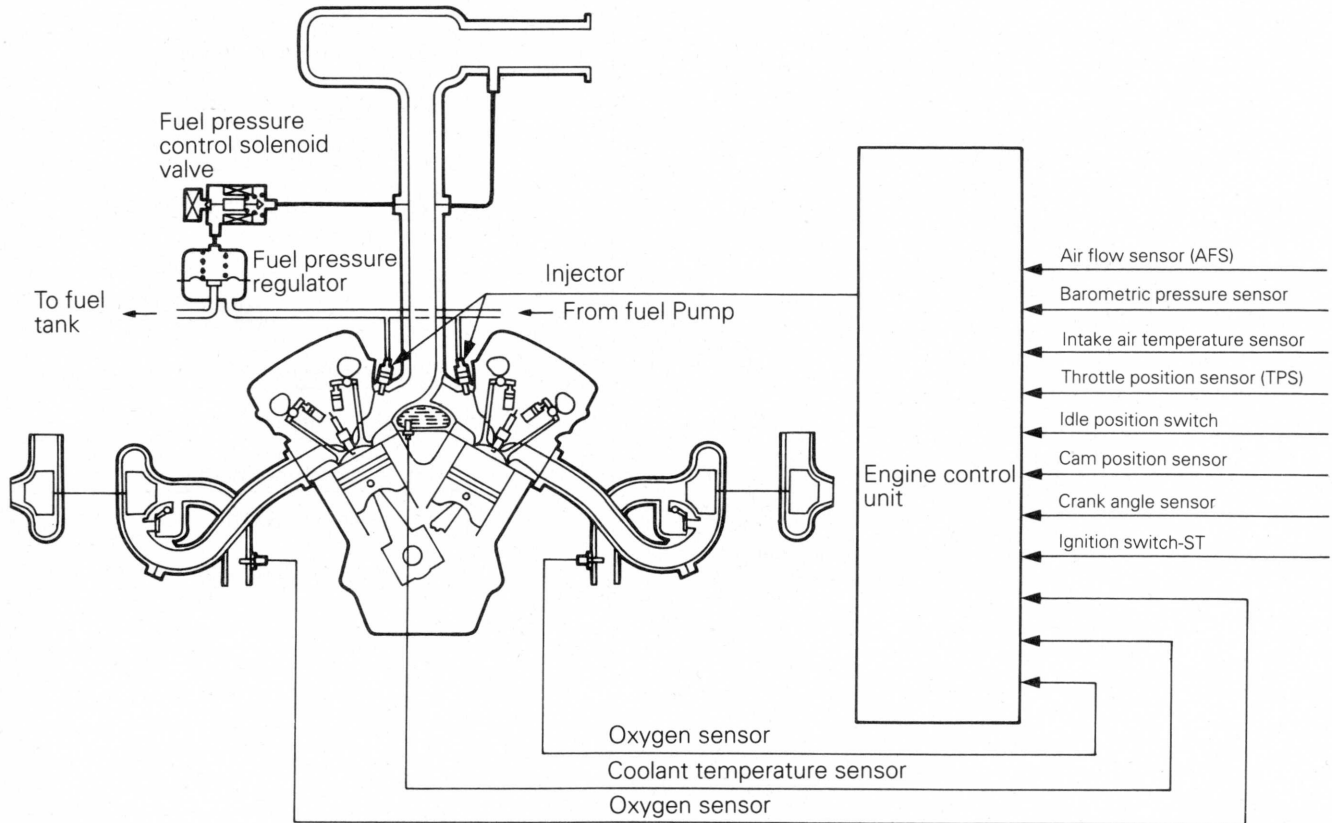

IDLE SPEED CONTROL (ISC)

(1) Stepper motor (STM) position control with the anti-lock braking system (ABS) function was added.

(2) Other controls are basically the same control system as in the conventional 6G72 engine.

SYSTEM CONFIGURATION DIAGRAM

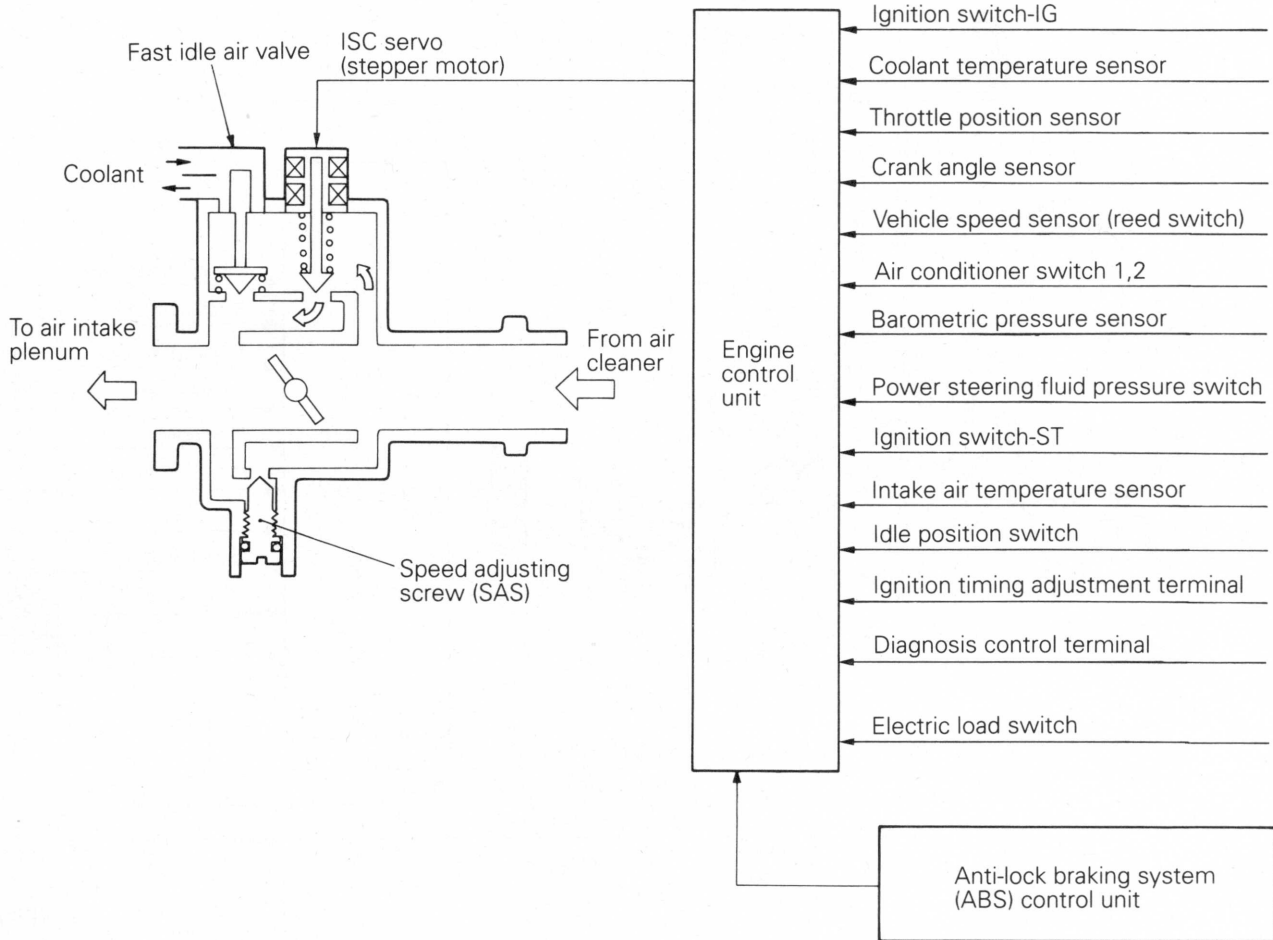

MECHANICAL DASHPOT

There is a mechanical dashpot which gradually closes the throttle valve from a set opening during deceleration to improve deceleration feeling.

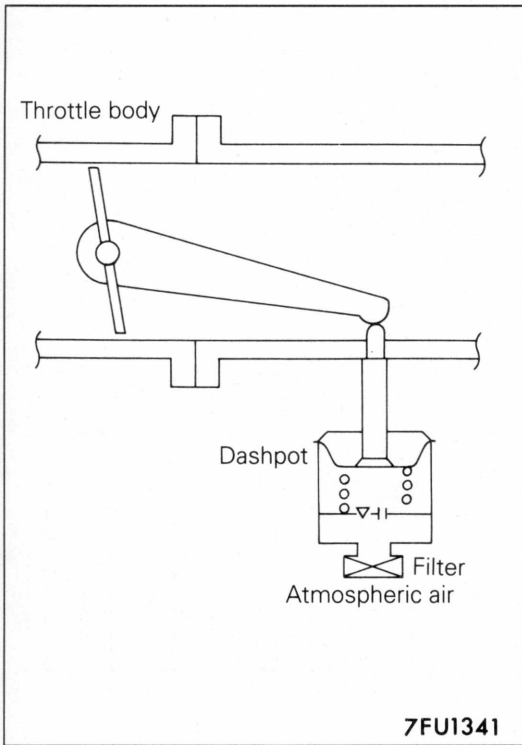

IGNITION TIMING AND ON TIME CONTROL

The ignition timing and on time control methods are basically the same as those used before.

SYSTEM CONFIGURATION DIAGRAM

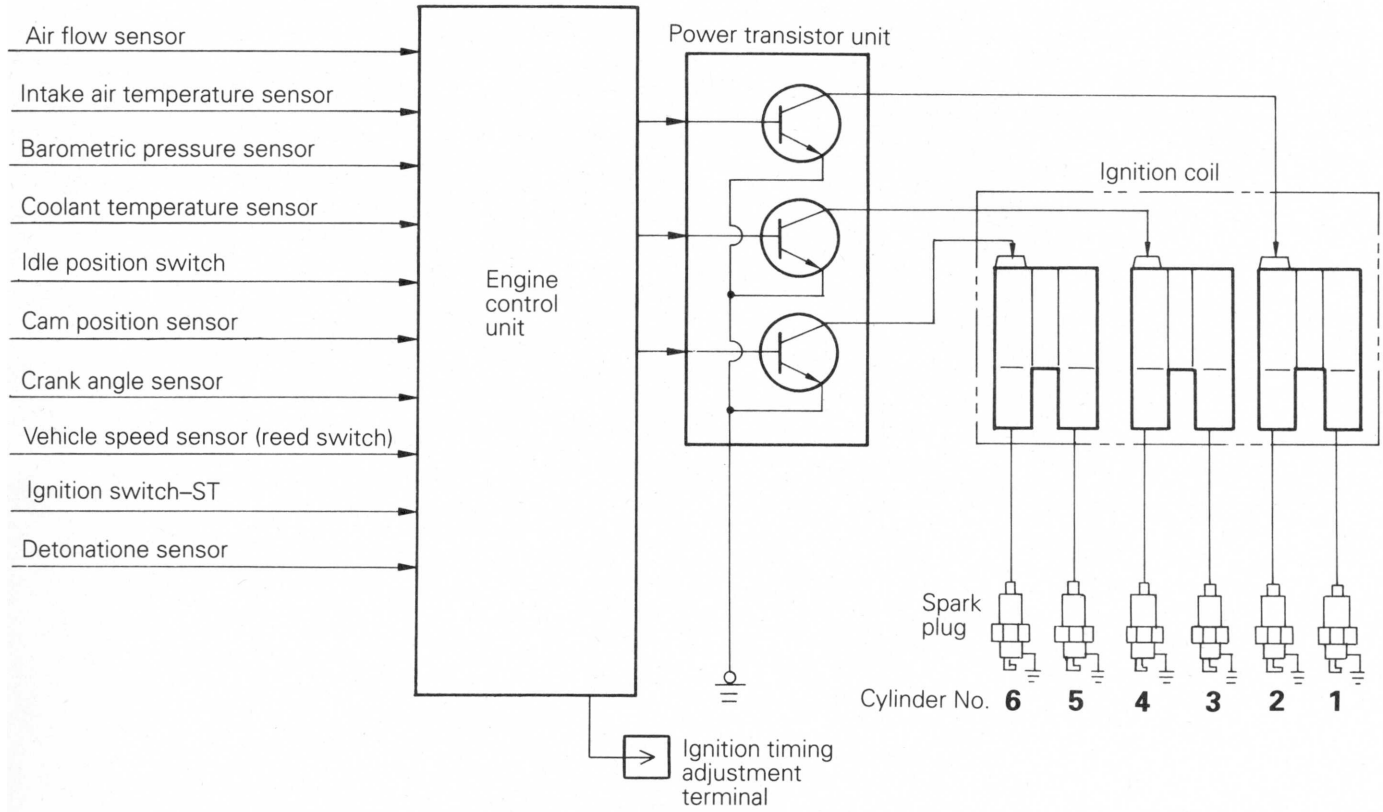

POWER SUPPLY AND FUEL PUMP CONTROL

Power supply control to the injector, air flow sensor, ISC servo, etc. is the same as in the conventional 6G72 engine.

Fuel pump control for controlling power supply to the fuel pump is also the same as in the conventional 6G72 engine.

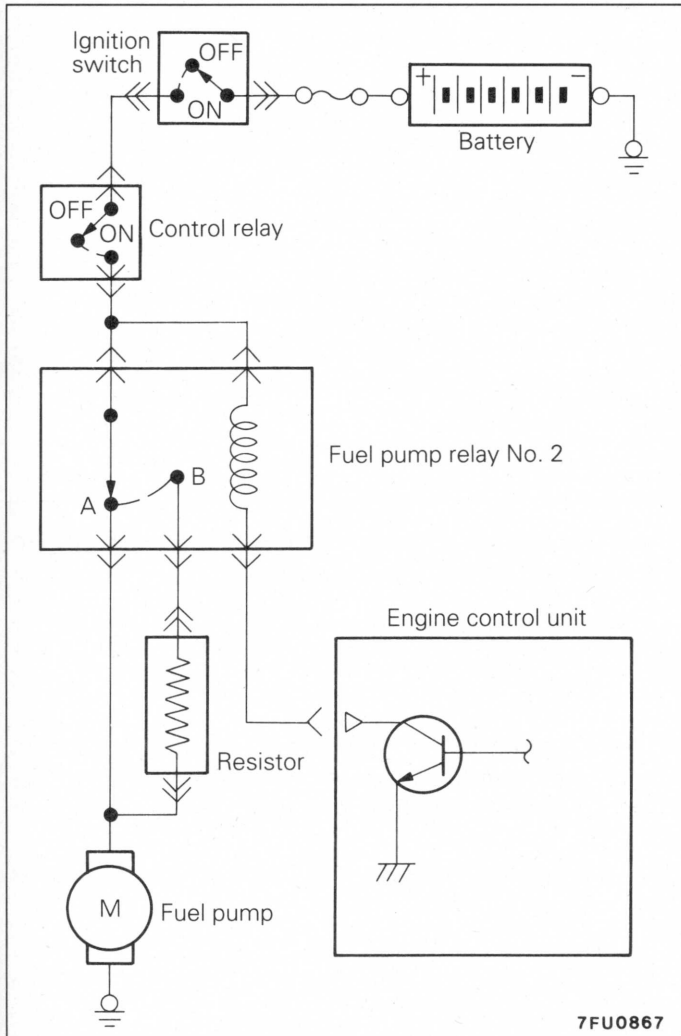

FUEL PUMP DISCHARGE VOLUME CONTROL

Fuel pump discharge volume is controlled in two steps according to the amount of intake air (engine load) in 1 cylinder in 1 cycle for improved reliability of the fuel pump. When the amount of intake air in this 1 cylinder 1 cycle is small (engine load is low), the engine control unit turns on the power transistor so current flows in the coil of fuel pump relay No.2. As a result, the relay switch changes from A to B (refer to the figure on the left.), and current flows via the resistor to the fuel pump motor. The supply voltage to the fuel pump is reduced since the voltage is lowered by the resistor, pump speed falls and the amount of fuel discharged from the fuel pump is reduced.

When the amount of intake air in this 1 cylinder 1 cycle is large (engine load is high), the engine control unit turns off the power transistor and changes the relay switch from B to A (refer to the figure on the left.). As a result, voltage drop due to the resistor increases, pump speed rises and the amount of fuel discharged from the fuel pump increases.

TURBO METER CONTROL

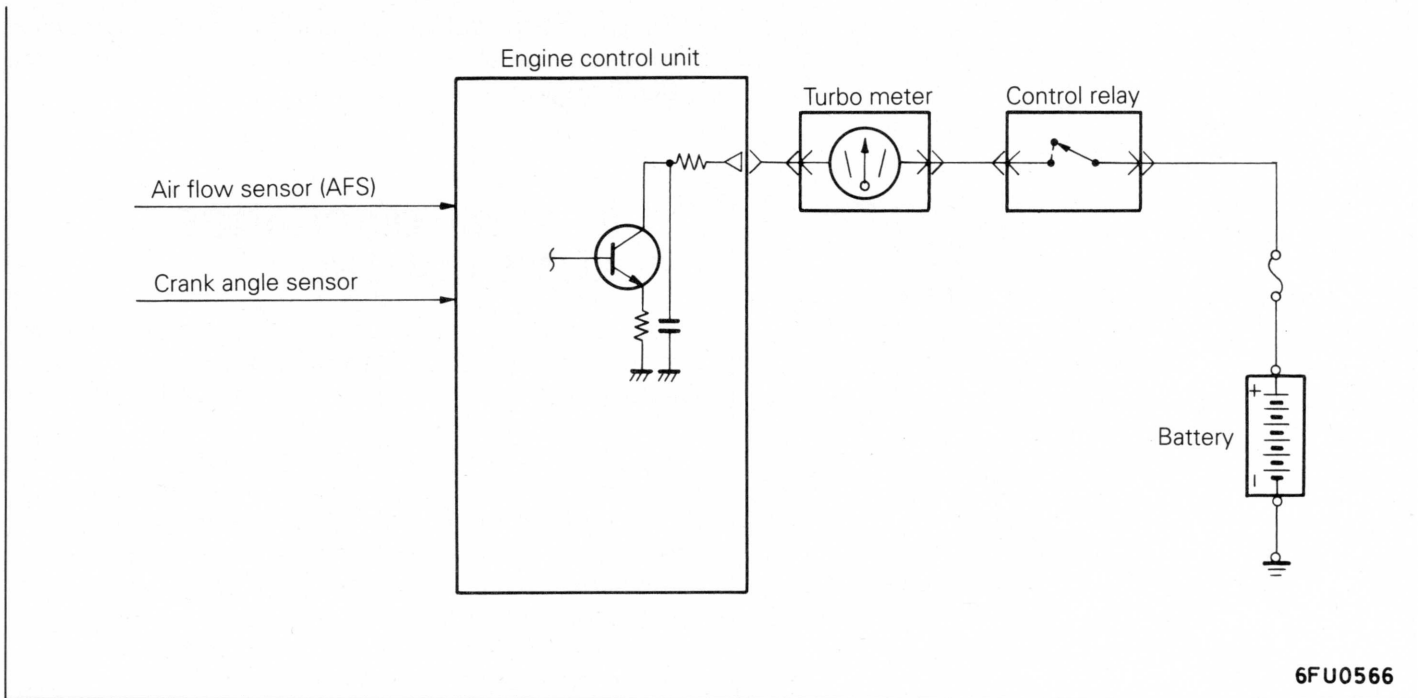

The turbo meter is a current type meter. The engine control unit receives the intake air volume signal from the air flow sensor and the rpm signal from the crank angle sensor and calculates the engine load.

Then, the unit determines the duty ratio according to the load and drives the turbo meter.

$$\text{Duty ratio} \approx \text{Load} \approx \frac{\text{Intake Air volume}}{\text{r/min}}$$

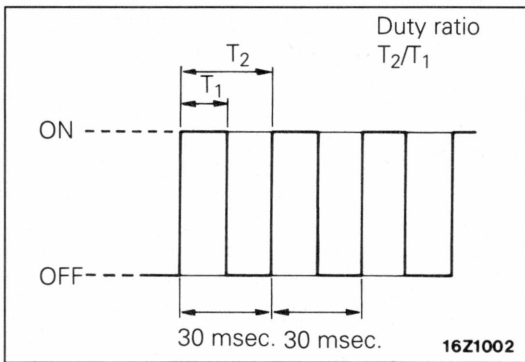

Duty Ratio

The duty ratio is defined as ON time ratio T_2/T_1 of a 33.3 Hz pulse. When the duty ratio increases, average current that flows to the turbo meter also increases so that the turbo meter indicates higher value. When the duty ratio is decreased, the turbo meter indicates smaller value.

TURBO PRESSURE CONTROL

Turbo pressure used in the waste gate actuator is controlled by duty control of the waste gate solenoid

valve. As a result, turbo pressure corresponding to driving conditions can be obtained.

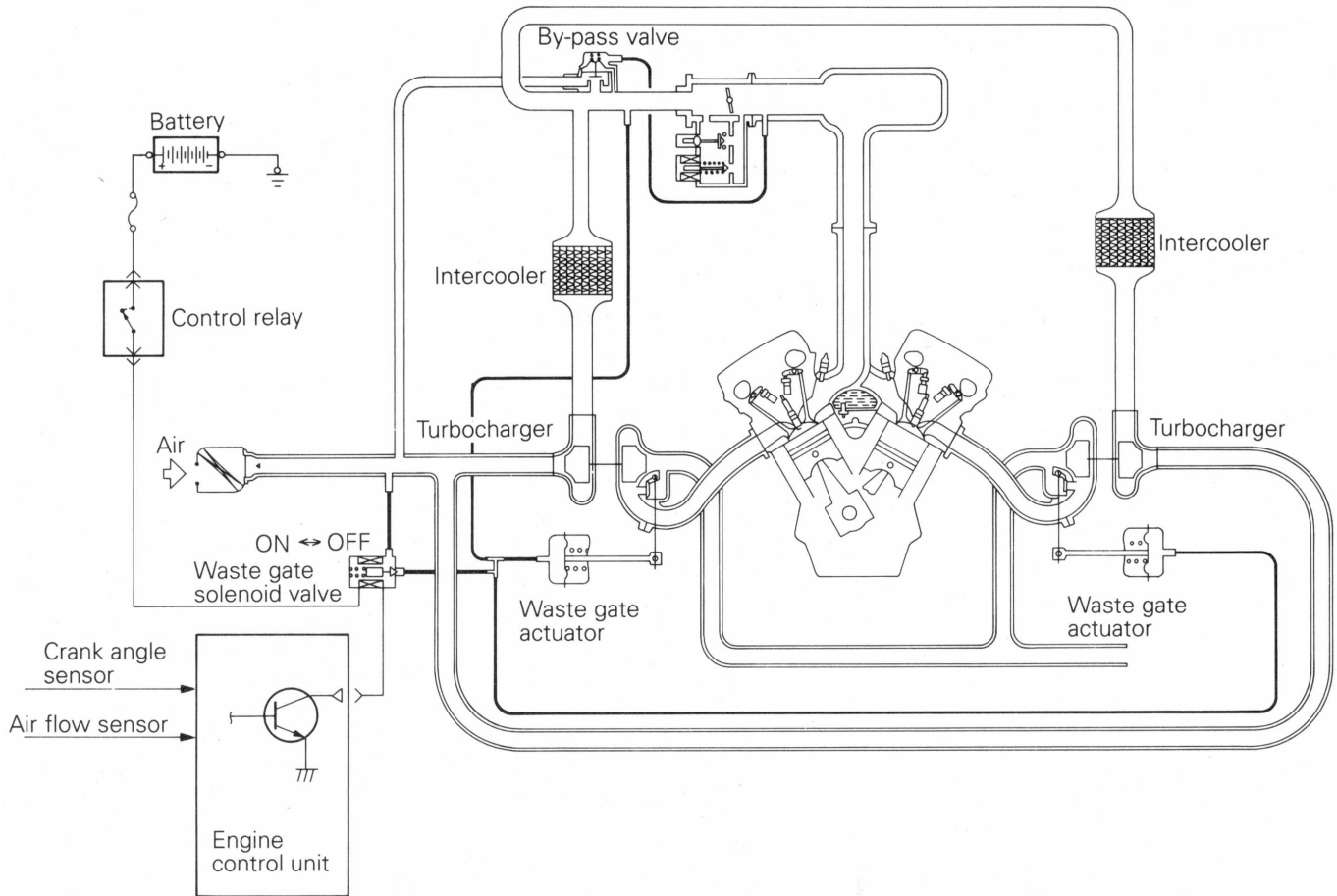

7FU0868

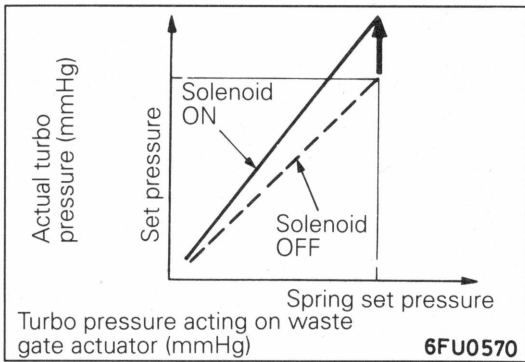

The engine control unit turns the power transistor in the unit on and, when normal current (duty 100%) flows in the waste gate solenoid valve coil, the waste gate solenoid valve does not open if turbo pressure does not rise above the set pressure of the waste gate actuator spring since some of the turbo pressure used in the waste gate actuator leaks out.

On the other hand, when current does not flow in the waste gate solenoid valve coil (duty 0%), the waste gate valve opens if turbo pressure rises to the set pressure of the waste gate actuator spring since no pressure leaks out.

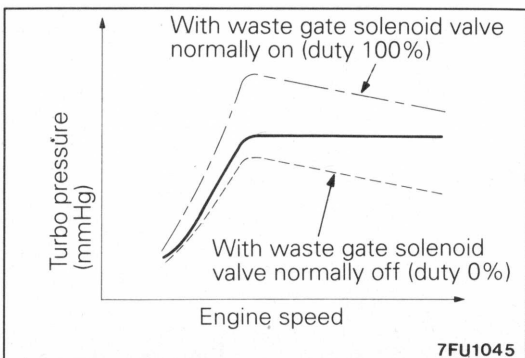

Consequently, by using duty control for the waste gate solenoid valve, turbo pressure can be controlled in a range from 00/0 to 100% duty.

This duty control is performed in cycles of approximately 60 ms.

FUEL PRESSURE CONTROL

FUEL SYSTEM-FUEL PRESSURE CONTROL VALVE (Refer to P. 1-12)
AIR FLOW SENSOR (AFS) FILTER RESET CONTROL, AIR CONDITIONER
RELAY CONTROL

These controls are the same as those for the conventional 6G72 engine.

SELF DIAGNOSIS SYSTEM

The following items have been made more complete.

- (1) Check engine lamp ON items
- (2) Self diagnosis items
- (3) Service data items to be transferred to multi-use tester
- (4) Actuator test items by multi-use tester

CHECK ENGINE LAMP CONTROL

The check engine lamp ON items are shown in the following table.

Oxygen sensor <Except for General Export and GCC>	Barometric pressure sensor
Air flow sensor (AFS)	Detonation sensor
Intake air temperature sensor	Ignition timing adjustment signal*
Throttle position sensor	Injector
Coolant temperature sensor	Ignition coil, power transistor unit
Crank angle sensor	
Cam position sensor	Engine control unit

Remarks

*: The check engine lamp lights even when the ignition timing adjustment terminal is short-circuited to the earth during an injection timing adjustment.

SELF DIAGNOSIS FUNCTIONS

- (1) Arrangements have been made to allow changeover of the diagnosis mode from DIAGNOSIS 1 mode to DIAGNOSIS 2 mode by sending a diagnosis mode changeover signal from the multiuse tester.
In the DIAGNOSIS 2 mode, note that the time from when a fault is detected to when it is determined as a fault is shorter than in the DIAGNOSIS 1 mode (4 seconds → 1 second).

- When the multi-use tester is disconnected from the diagnosis connector, all fault codes will be cleared from the memory, and the DIAGNOSIS 2 mode will be changed back to the DIAGNOSIS 1 mode.
- (2) The other functions remain unchanged.
- (3) The diagnosis items are as shown in the following table.

Code No.	Diagnosis item	Description	DIAGNOSIS 2 Mode
11	Oxygen sensor (Rear bank) <Except for General export and GCC>	Malfunction of the air/fuel ratio control system Open or short circuit in the oxygen sensor circuit	-
12	Air flow sensor	Open or short circuit in sensor and allied circuit	Valid
13	Intake air temperature sensor	Open or short circuit in sensor and allied circuit	Valid
14	Throttle position sensor	Abnormal sensor output	Valid

Code No.	Diagnosis item	Description	DIAGNOSIS 2 Mode
21	Coolant temperature sensor	<ul style="list-style-type: none"> ● Open or short circuit in sensor and allied circuit ● Increased connector contact resistance 	Valid
22	Crank angle sensor	Abnormal sensor output	Valid
23	Cam position sensor	Abnormal sensor output	Valid
24	Vehicle speed sensor (reed switch)	Open or short circuit in sensor circuit	Valid
25	Barometric pressure sensor	Open or short circuit in sensor circuit	Valid
31	Detonation sensor	Abnormal sensor output	Valid
36*	Ignition timing adjustment signal	Short circuit in ignition timing adjustment signal line	-
39	Oxygen sensor (Front bank) <Europe, Hong Kong and Singapore>	Malfunction of the air/fuel ratio control system Open or short circuit in the oxygen sensor circuit	-
41	Injector (Rear bank)	Open circuit in injector and allied circuit	Valid
44	1-4 cylinder ignition coil, power transistor unit	Abnormal ignition signal (No coil primary voltage generated)	Valid
52	2-5 cylinder ignition coil, power transistor unit	Abnormal ignition signal (No coil primary voltage generated)	Valid
53	3-6 cylinder ignition coil, power transistor unit	Abnormal ignition signal (No coil primary voltage generated)	Valid
-	Normal	-	-

*: Fault code No. 36 is not memorized.

SERVICE DATA OUTPUT

The service data output items are shown in the following table.

Item No.	Service data item	Unit
11	Oxygen sensor output (Rear bank) <Except for General Export and GCC>	mV
12	Air flow sensor output	Hz
13	Intake air temperature sensor output	°C
14	Throttle position sensor output	mV
16	Battery voltage	V
17	Mixture adjusting screw (variable resistor) <GCC, general export>	ON - OFF
18	Cranking signal (ignition switch-ST)	ON - OFF
21	Coolant temperature sensor output	°C
22	Crank angle sensor output	RPM
25	Barometric sensor output	mmHg
26	Idle position switch	ON - OFF

Item No.	Service data item	Unit
27	Power steering fluid pressure switch	ON - OFF
28	Air conditioner switch	ON - OFF
33	Electric load switch	ON - OFF
34	Air flow sensor reset signal	ON - OFF
36	Ignition timing adjustment mode	ON - OFF
37	Volumetric efficiency	%
38	Crank angle sensor output (readable at 2,000 rpm or less)	RPM
39	Oxygen sensor output (Front bank) <Europe, Hong Kong and Singapore>	mV
41	Injector drive time (Rear bank)	mS
44	Ignition advance angle value	°BTDC, °ATDC
45	ISC stepper motor position	STEP
47	Injector drive time (Front bank)	mS
49	Air conditioner relay	ON - OFF

ACTUATOR TESTS

The actuator test items are shown in the following table.

NOTE

The items that have been added to the conventional system are shown in bold letters.

Item No.	Actuator test item
01	NO.1 injector: OFF
02	NO.2 injector: OFF
03	NO.3 injector: OFF
04	NO.4 injector: OFF
05	NO.5 injector: OFF
06	NO.6 injector: OFF
07	Fuel pump: ON
08	Purge control solenoid valve: ON <Europe, Hong Kong and Singapore>
09	Fuel pressure control valve: ON
10	EGR control solenoid valve: ON <Except for Australia>
12	Waste gate solenoid valve: ON
13	Fuel pump relay No.2: ON (Current flows via the resistor)
17	Ignition timing: 5° BTDC

OIL LEVEL WARNING SYSTEM

This system is the same as that of the conventional 6G72 engine.

EMISSION CONTROL SYSTEM

The emission control system is basically the same as that used in the 6G72 engine fitted to the PAJERO/MONTERO. However, the following additions have been made to the system in vehicles for Europe, Hong Kong and Singapore only.

- (1) Oxygen sensors and a front catalytic converter have been added to reduce the level of exhaust gas emissions.
- (2) The evaporative emission control system has been improved as shown below. The fuel vapour intake amount from the canister has been increased so

that the amount of vapour that escapes to the atmosphere has been reduced.

- When driving with a low to medium load on the engine, the fuel vapour absorbed by the canister is drawn into the P port of the throttle body in the same way as in engines without turbocharger.
- When driving with a high load on the engine, the purge control valve opens and the fuel vapour absorbed by the canister is drawn into the air intake hose.

System	Applicable destination					Remarks
	Europe	Hong Kong, Singapore	Australia	GCC	General Export	
Crankcase ventilation system	X	X	X	X	X	
Evaporative emission control system	X	X	X	X	-	Electronics controlled type (Europe, Hong Kong and Singapore) Vacuum controlled type (Australia and GCC)
Catalytic converter	X	X	X	-	-	Three way catalyst
Air fuel ratio closed loop control	X	X	X	-	-	Oxygen sensor signal used
Exhaust gas recirculation system	X	X	-	X	X	Electronics controlled type

Emission Control System Diagram
<Europe, Hong Kong and Singapore>

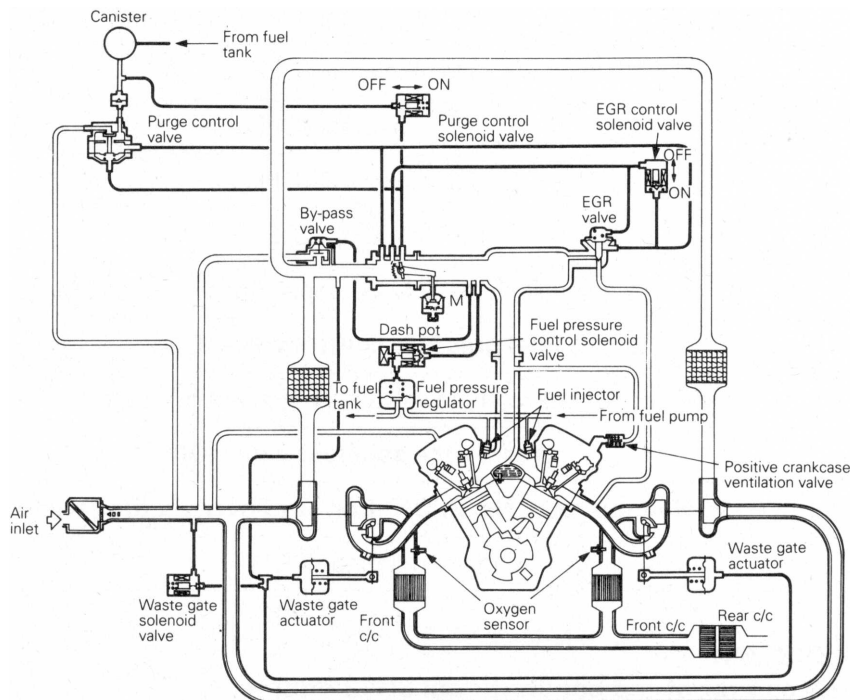

<Australia>

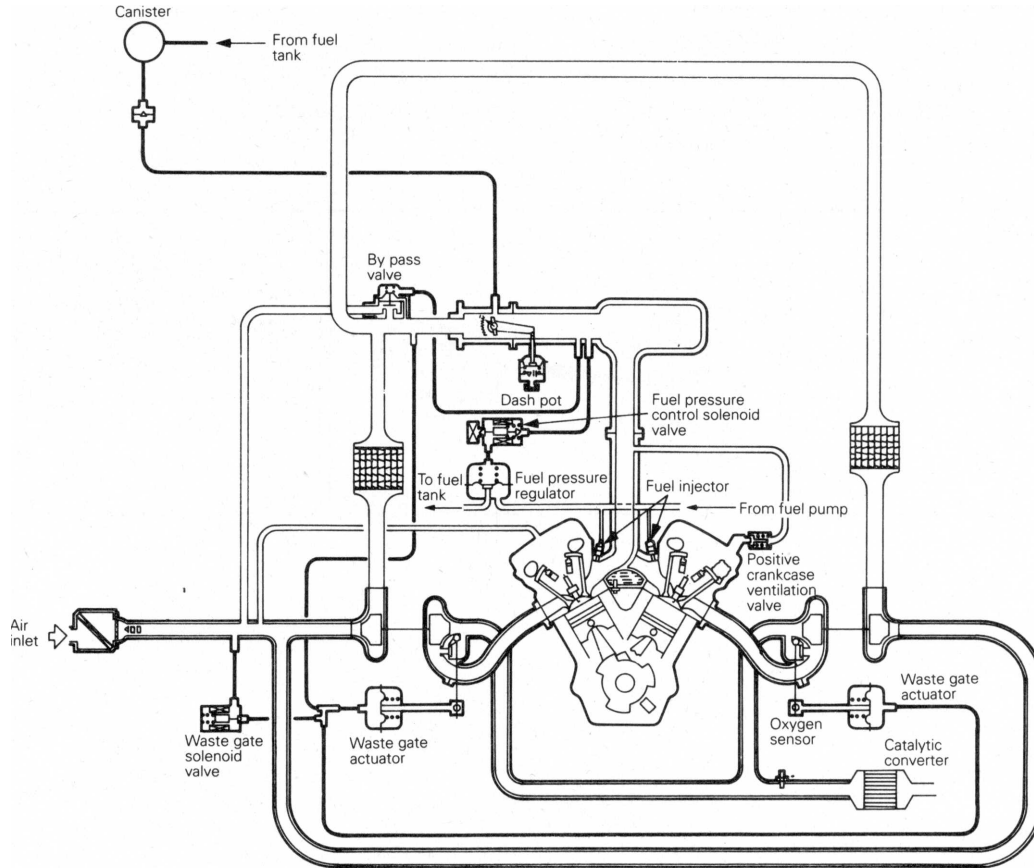

7FU1343

<GCC and General Export>

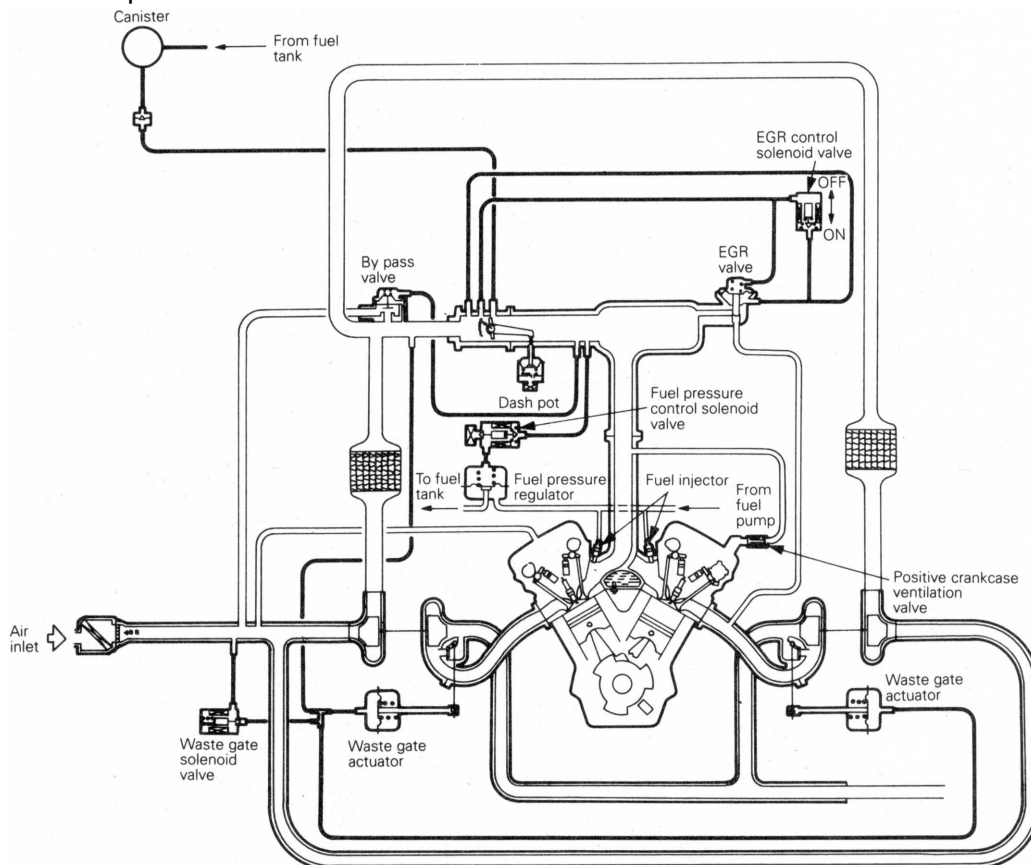

7FU1344

CRUISE CONTROL SYSTEM

The cruise control system makes constant-speed driving possible at a speed designated by the driver [within a range of approx. 40 - 200km/h (25 - 125m ph)] without depressing the accelerator pedal.

NOTE

The cruise control system is basically the same as the system equipped in the SIGMA.

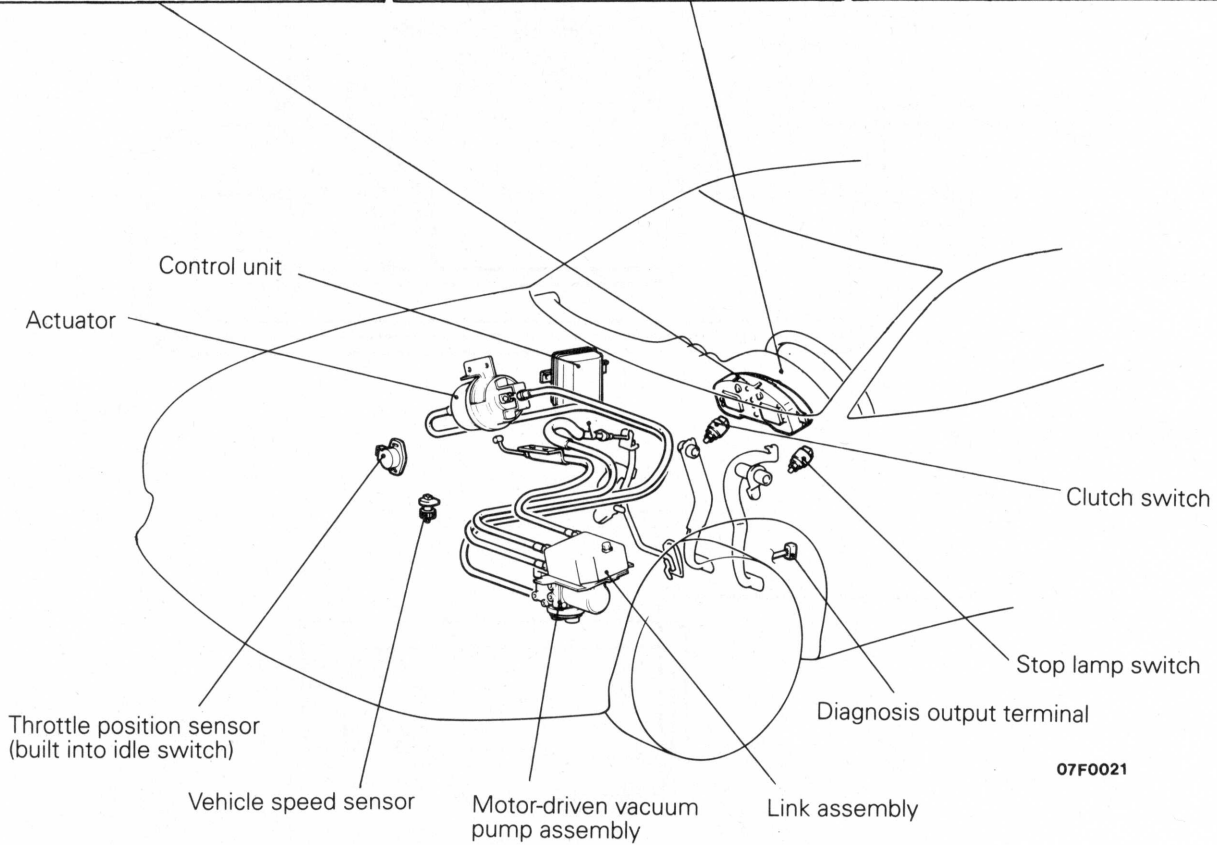
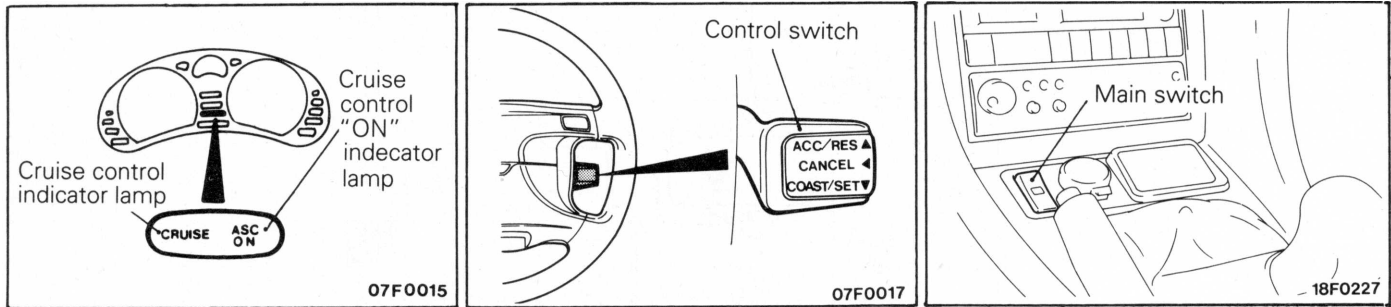

POWER- TRANSMISSION COMPONENTS

CONTENTS

CLUTCH	2	FRONT AXLE	12
Specifications	2	Specifications	12
Clutch Booster	3		
MANUAL TRANSMISSION	4	REAR AXLE	13
Specifications	4	Specifications	13
Sectional View	5	Axle Shaft	13
W5MG1 4WD Transmission	6	Drive Shaft	13
Transmission Control	10	Differential	15
PROPELLER SHAFT	11	Differential Support	16
Specifications	11		

CLUTCH

The clutch is the dry single-plate diaphragm type; A hydraulic type with clutch booster is used for the clutch control.

Some models are equipped with a clutch damper in the clutch tube to make changes in hydraulic pressure smoother when the clutch is engaged and to reduce the maximum value for the clutch input torque.

SPECIFICATIONS

Items	Specifications
Clutch operating method	Hydraulic type
Clutch disc Type	Single dry disc type
Facing diameter 0.0. x 1.0. mm (in.)	250 x 160 (9.8 x 6.3)
Clutch cover assembly Type	Diaphragm spring strap drive type
Setting load N (kg,lbs.)	9,200 (920, 2,024)
Clutch release cylinder 1.0. mm (in.)	19.05 (3/4)
Clutch master cylinder 1.0. mm (in.)	15.87 (5/8)
Clutch booster Type	Vacuum type, single
Effective dia. of power cylinder mm (in.)	101 (4.0)
Boosting ratio [Clutch pedal depressing force]	1.7 [at 110 N (11 kg, 24 lbs.)]
Vacuum tank Capacity dm ³ (U.S. qts., Imp. qts.)	1.2 (1.27, 1.06)

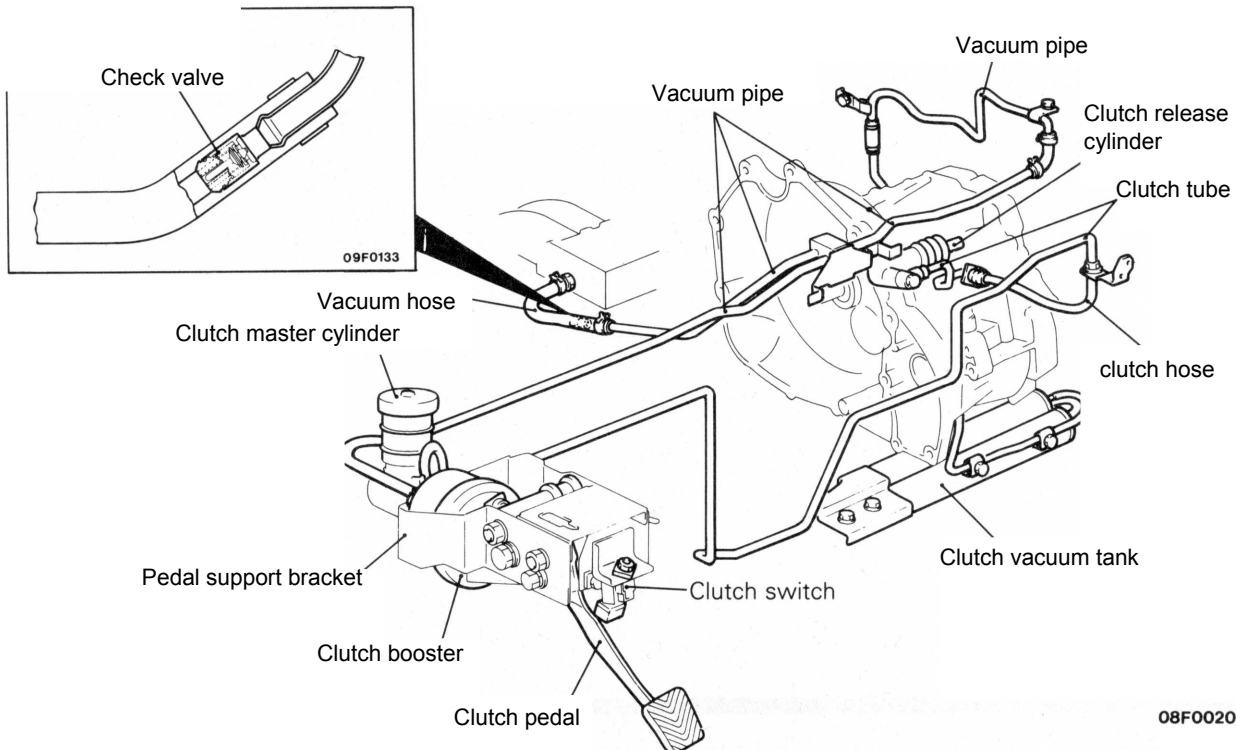

CLUTCH BOOSTER

A 4" single type clutch booster is used to reduce the force to depress the pedal. The structural operation

of the clutch booster is basically the same as with the brake booster.

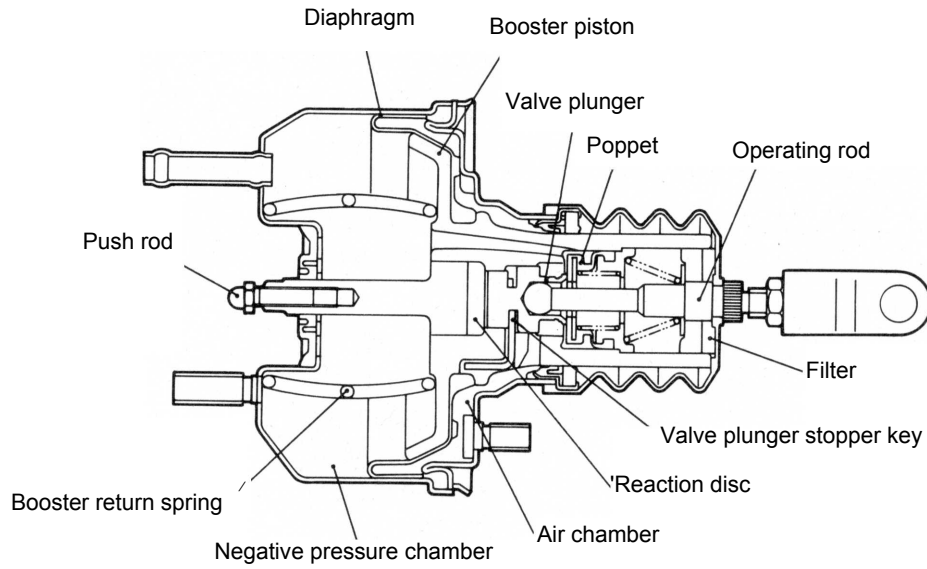

08F0007

2-4 POWER-TRANSMISSION COMPONENTS - Manual Transmission

MANUAL TRANSMISSION

The manual transmission is a W5MG1 transmission. A cable type floor shift is used for transmission control. The W5MG1 is a transmission that has been newly developed to respond to the high output and high torque of the 6G72-DOHC-Turbo engine.

SPECIFICATIONS

Items	Specifications
Transmission model	W5MG1
Type	5-speed constant-mesh cable controlled type
Gear ratio (number of gear teeth)	
1 st	3.071 (43/14)
2nd	1.739 (40/23)
3rd	1.103 (32/29)
4th	0.823 (28/34)
5th	0.659 (31/47)
Reverse	3.076 (40/13)
Primary reduction ratio (number of gear teeth)	1.375 (44/32)
Front differential gear ratio (number of gear teeth)	2.888 (52/18)
Transfer gear ratio (number of gear teeth)	0.814 (22/27)
Torque split ratio	Front/Rear 45/55
Speedometer gear ratio	Drive/Driven 27/36

SECTIONAL VIEW

W5MG1

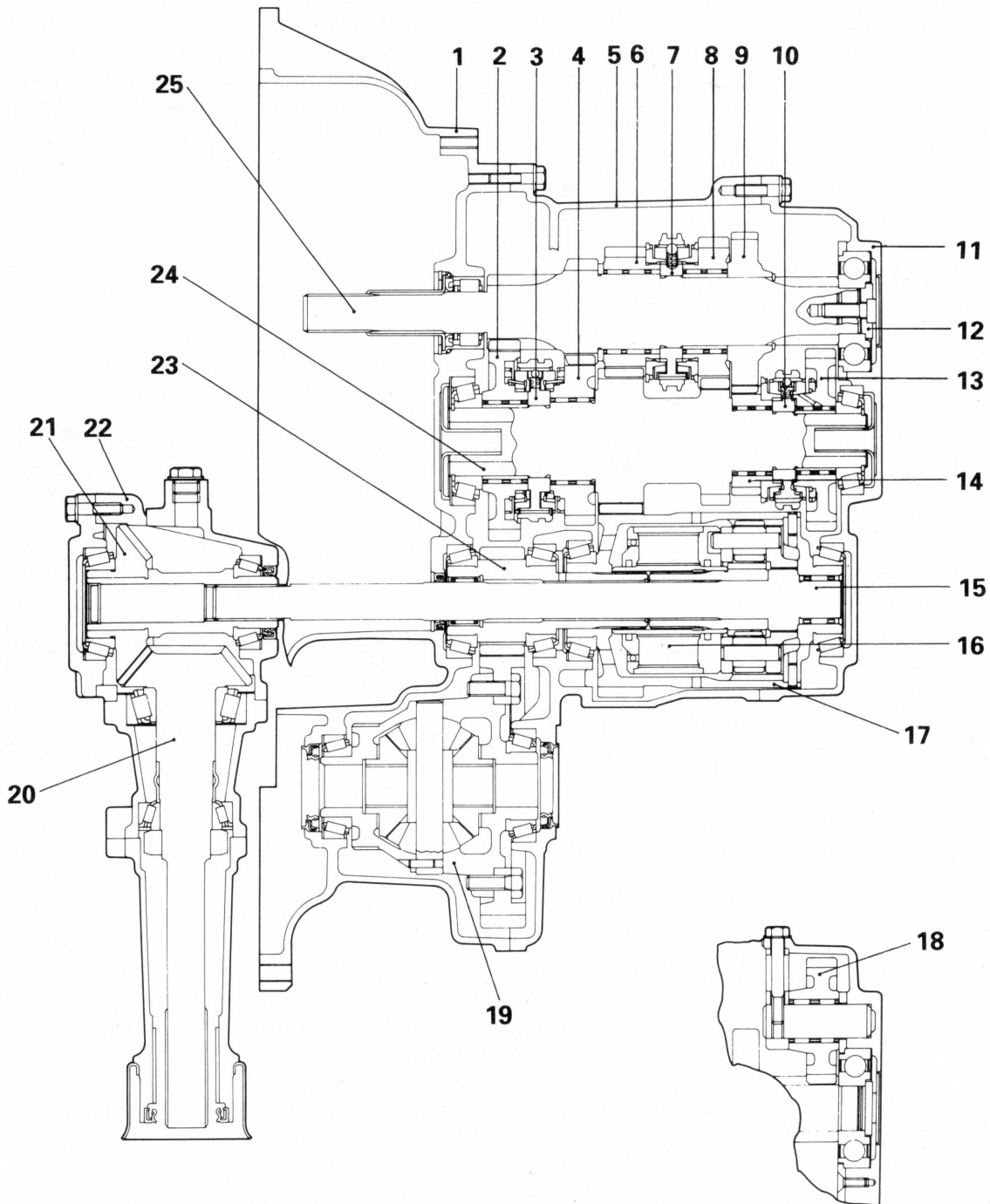

- | | |
|----------------------------------|--------------------------------|
| 1. Clutch housing | 14. 5th speed gear |
| 2. 1st speed gear | 15. Center shaft |
| 3. 1st-2nd synchronizer hub | 16. Viscous coupling |
| 4. 2nd speed gear | 17. Center differential |
| 5. Transaxle case | 18. Reverse idler gear |
| 6. 3rd speed gear | 19. Front differential |
| 7. 3rd-4th synchronizer hub | 20. Transfer driven bevel gear |
| 8. 4th speed gear | 21. Transfer drive bevel gear |
| 9. 5th speed gear input shaft | 22. Transfer case |
| 10. 5th-reverse synchronizer hub | 23. Front output shaft |
| 11. Rear cover | 24. Intermediate shaft |
| 12. Input shaft retainer | 25. Input shaft |
| 13. Reverse gear | |

TFM0110

2-6 POWER-TRANSMISSION COMPONENTS - Manual Transmission

W5MG1 4WD TRANSMISSION

The W5MG1 is a 3-shaft, full time 4WD transmission. It is not only a planetary gear type differential with the center differential on the NO.3 shaft used, but also a viscous coupling acting as a differential limiter that is built into the front and rear output shafts.

The gear meshing method is a constant-mesh method also used for reverse.

The reverse idler gear is on the rear cover.

A double-cone synchronizer is used for 1st speed and 2nd speed for improved shift feeling.

A double-mesh prevention device using an interlock plate and a reverse mis-shift prevention device using a stopper plate are adopted in the shift control system.

The construction and operation of the double-mesh prevention device, and reverse mis-shift prevention device are basically the same as on the 4WD transmission previously used.

PLANETARY GEAR TYPE CENTRE DIFFERENTIAL

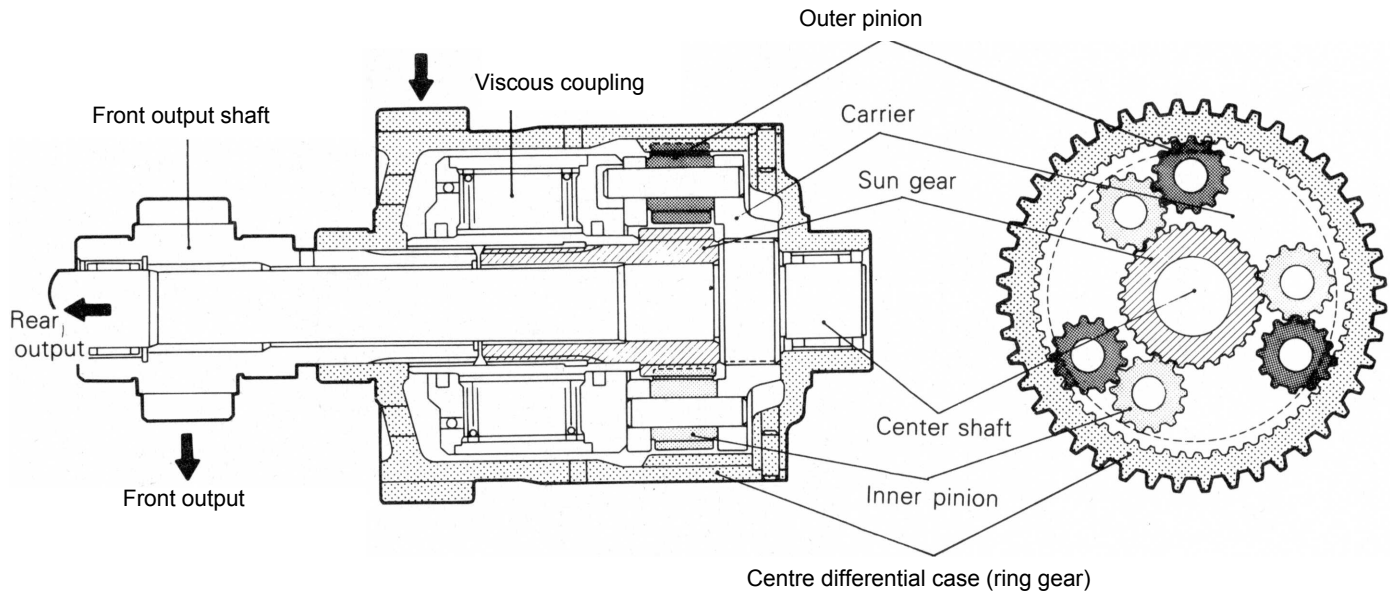

09F0126

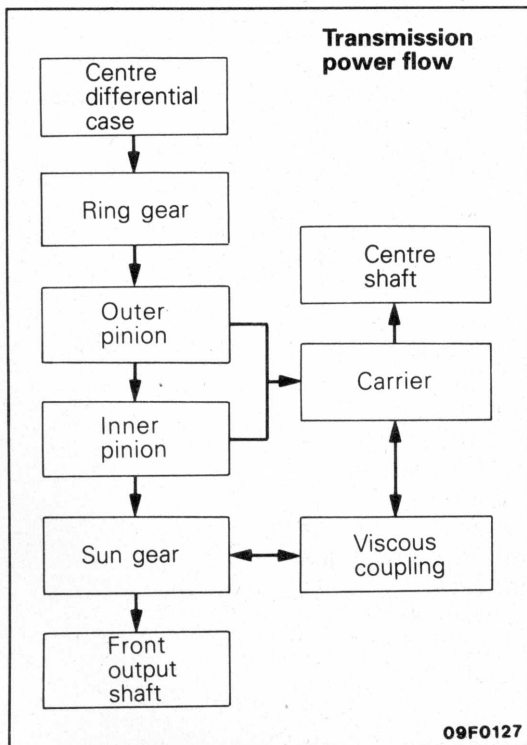

The centre differential has the construction shown in the figure above, and is made up of the differential case (integral part of ring gear), outer pinions (3 pc.), inner pinions (3 pc.), carrier, sun gear, front output shaft, centre shaft and viscous coupling. Drive force input from the outside of the differential case is transmitted to the outer pinions and inner pinions by the ring gear on the inside of the case, from there is distributed to the sun gear and carrier to be transmitted to the front output shaft and centre shaft.

Furthermore, since there is a viscous coupling built in this centre differential, when a rotational speed difference arises between the front output shaft and centre shaft, differential control torque is redistributed according to that difference so that the ideal drive force is always maintained.

In addition, unequal torque distribution is used in this centre differential.

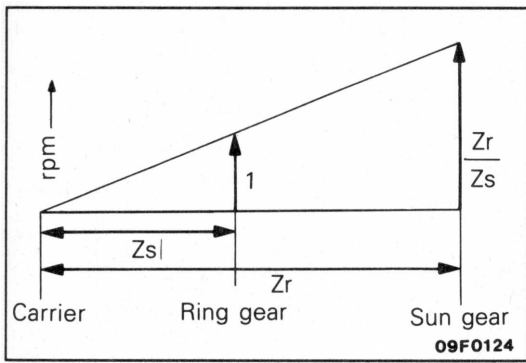

The distribution of the drive force to the carrier and sun gear in a planetary gear type differential is determined by the number of teeth on the ring gear and sun gear.

Here is the figure of the velocity diagram if the number of teeth on the ring gear is Z_r and the number of teeth on the sun gear is Z_s .

The carrier is considered to be fixed, the ring gear and sun gear revolve in the same direction, and the sun gear rotates Z_r/Z_s for one rotation of the ring gear. The figure on the left shows the velocity diagram for such a case.

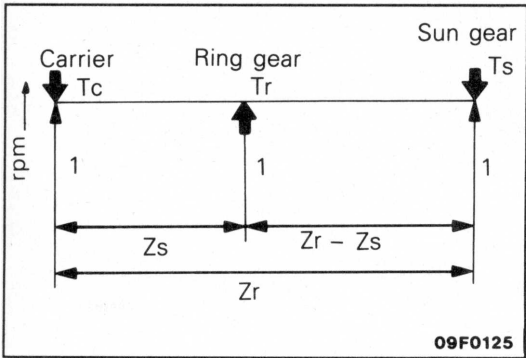

According to the velocity diagram, the result is as follows if we consider a state of balance with the ring gear in the center when the ring gear and sun gear rotate at the same speed.

If

T_r : Ring gear input torque

T_s : Sun gear output torque (front output)

T_c : Carrier output torque (rear output)

Then

(1) $T_r = T_c + T_s$

(2) $T_c \times Z_s = (Z_r - Z_s) \times T_s$

From (1) and (2)

$T_s = Z_s/Z_r \times T_r$

$T_c = (Z_r - Z_s)/Z_r \times T_r$

$T_s : T_c = Z_s : Z_r - Z_s = \text{Front} : \text{Rear}$

With the W5MG1, $Z_r = 60$ and $Z_s = 27$, so $Z_r - Z_s = 33$.

Front: Rear = 27: 33 = 45 : 55.

DOUBLE-CONE SYNCHRONIZER

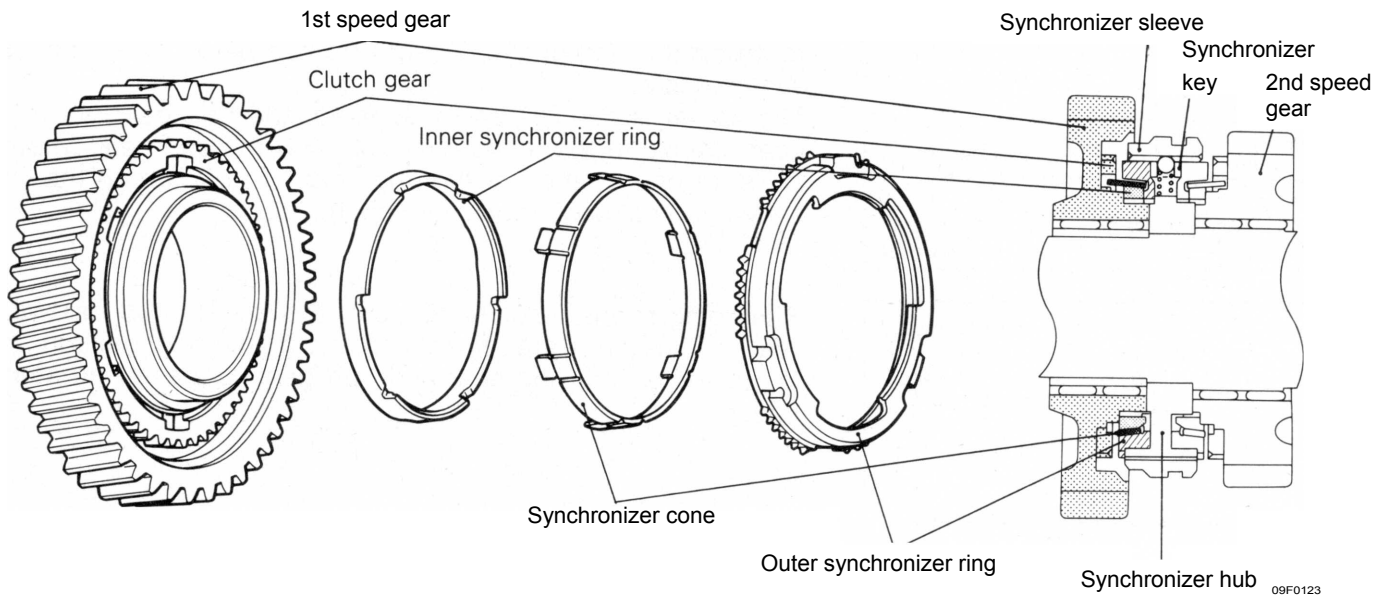

The double-cone synchronizer used for 1st speed and 2nd speed are made up, as shown in the figure above, of the speed gear, clutch gear (welded to the speed gear), inner synchronizer ring, synchronizer cone, outer synchronizer ring, synchronizer hub, synchronizer sleeve, synchronizer key, etc.

The inner synchronizer ring touches liner of the synchronizer cone inner surface at the outer cone surface and is coupled to the outer synchronizer ring by the projections (3 locations) on the synchronizer hub. The synchronizer cone touches the inner synchronizer ring and outer synchronizer ring at the inner surface liner and

outer surface liner respectively, and is coupled with the clutch gear by the projections (6 locations) on the speed gear.

The outer synchronizer ring touches the outer surface liner of the synchronizer cone at the inside cone surface and is coupled to the synchronizer hub by the projections (3 locations) on the outer circumference. In other words, the inner synchronizer ring and outer synchronizer ring become one unit with the synchronizer hub and rotate, and the synchronizer cone becomes one unit with the speed gear and rotates as they touch each other.

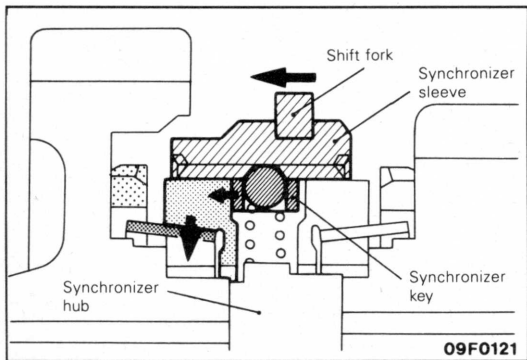

When the shift lever is moved toward 1st speed, the shift fork moves the synchronizer sleeve to the left.

At this time, since the ball in the synchronizer key is pressed into the groove of the synchronizer sleeve by the spring, the synchronizer sleeve and key are joined and move to the left. As a result, the outer synchronizer ring is pressed to the left, friction torque is generated between the synchronizer cone and outer synchronizer ring and inner synchronizer ring, and the 1st speed gear and synchronizer hub (intermediate shaft) begin to synchronize.

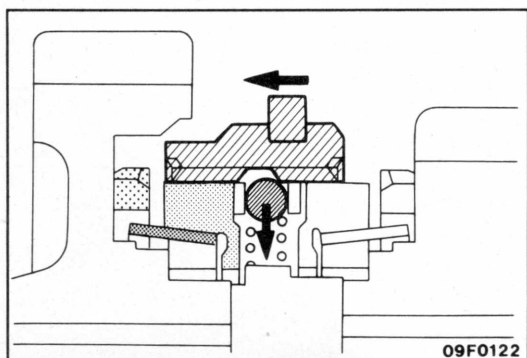

Then, when the shift fork moves to the left, the synchronizer sleeve pushes the synchronizer key spring tight, crosses over the synchronizer key and moves to the left.

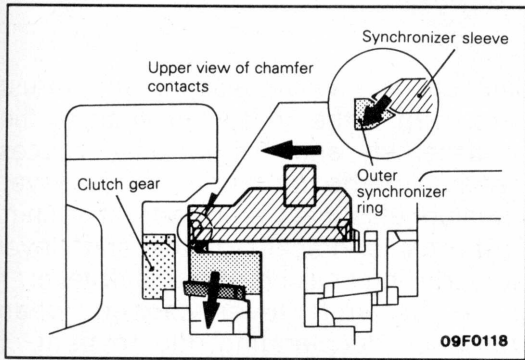

Then the chamfer of the outer synchronizer ring spline and the chamfer of the synchronizer sleeve spline come in contact. As a result of this contact, a major pushing force is generated in the outer synchronizer ring, the friction torque between the synchronizer cone and outer synchronizer ring and inner synchronizer ring increases, and then the difference in rotational speed of the 1st speed gear and the synchronizer hub disappears.

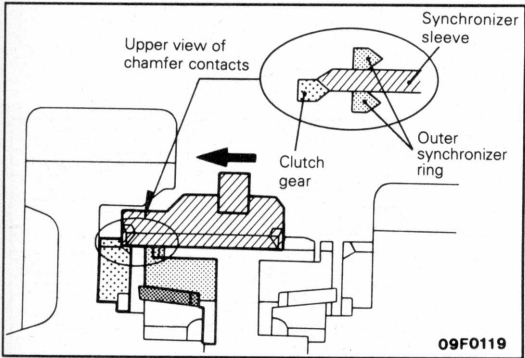

Under these conditions, since the synchronizer sleeve is pressed to the left, the synchronizer sleeve spline and outer synchronizer ring spline mesh.

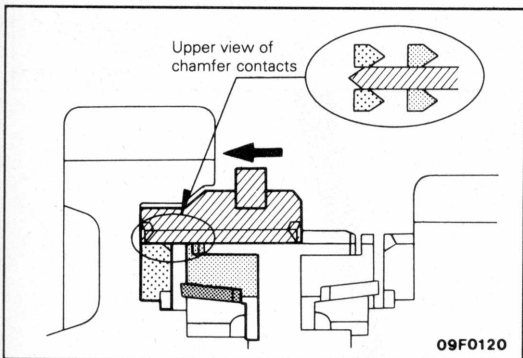

Also, when the synchronizer sleeve moves to the left, the synchronizer sleeve spline chamfer comes in contact with the clutch gear spline chamfer of the 1st speed gear, and then the clutch gear spline and synchronizer sleeve spline mesh to complete the shift to 1st speed.

TRANSMISSION CONTROL

- There are vibration-prevention rubber pieces mounted on the transaxle side of the shift cable and selector cable, and on the shift lever assembly side to prevent transmission of fine vibrations to the body.
- The eye end on the shift lever assembly of the shift cable has a double structure, a combination of a resin bushing and rubber bushing, and this not only provides smooth movement of the shift cable but also prevents transmission of vibration to the shift lever assembly, improving the shifting feel.
- A combination of a wave washer and thrust washer are used in the shift lever shaft of the shift lever assembly, and this not only reduces the looseness in the direction of the lever shaft but also elastically supports the shift cable on the cable bracket of the shift lever assembly, reducing shaking of the shift lever.
- Shaking of the shift lever caused when accelerating and decelerating due to bent of the shift and selector cables is reduced.

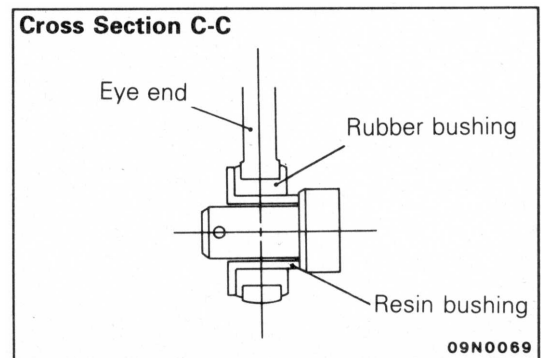
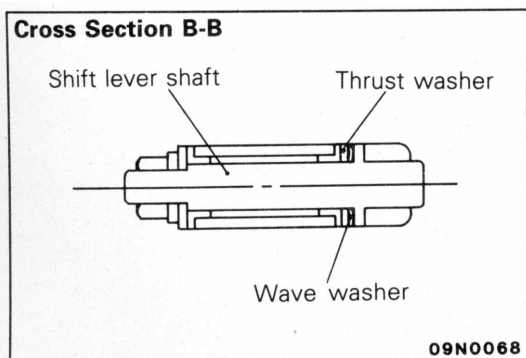
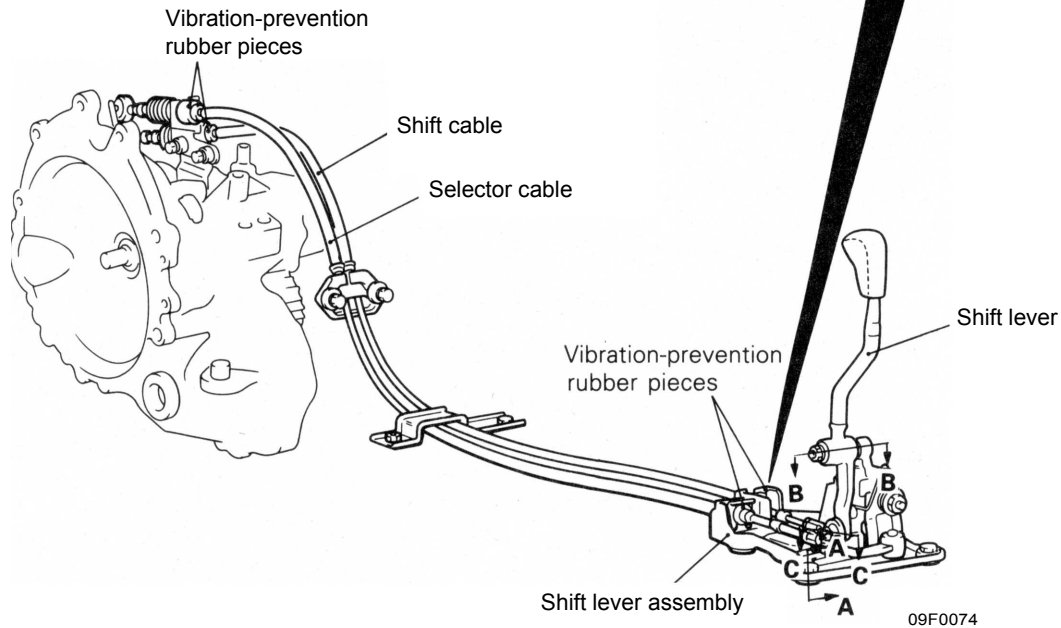
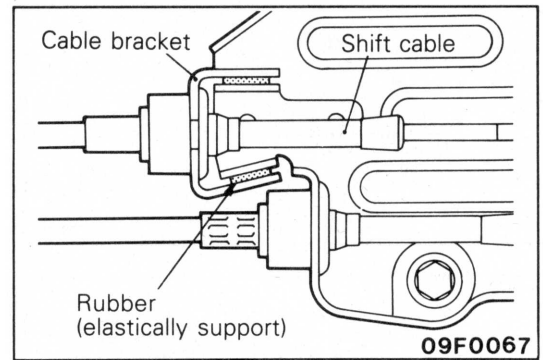
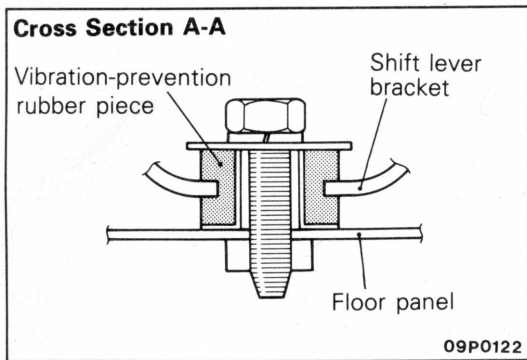

PROPELLER SHAFT

The propeller shaft is a 3-section 4-joint shaft with 2 center bearings. This division into 3 sections increases the vibration frequency characteristics of the shaft bending, and reduces vibration and noise when driving at high speed. The joints for connecting each part of the propeller shaft are as follows; No.1, No.2 and No. 4 joints are cross type universal joints and No.3 joint is a Lobro joint (LJ) that can slide and

has small friction in the direction of the shaft. This structure helps reducing torque fluctuation, vibration and noise. Furthermore, the rear propeller shaft is a vibration-control type shaft (using rubber) with an inner tube inserted in the outer tube to reduce vibration and noise from the drive train.

SPECIFICATIONS

Item		Specification	
Propeller shaft	Type	4-joint propeller shaft	
	Length x 0.0. mm (in.)	Front	673.5 x 65 (26.52 x 2.56)
		Center	662.5 x 65 (26.08 x 2.56)
		Rear	555.5 x 75 (21.87 x 2.95)
Universal joint	Type	No.1	Cross type
		No.2	Cross type
		No.3	Constant velocity type (L6bro joint, LJ95)
		No.4	Cross type
	Lubrication	Pre-packed	
	Size mm (in.)	Cross type joint journal O.D.	17.996 (0.7085)
Constant velocity joint O.D.		99.73 (3.93)	

NOTE

Propeller shaft length indicates the length between center points of each joint.

CONSTRUCTION DIAGRAM

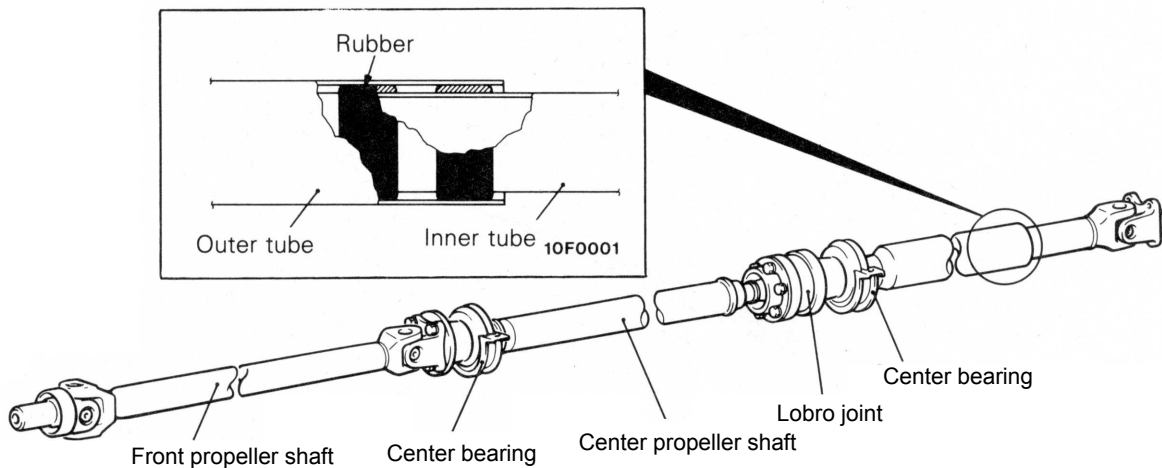

FRONT AXLE

The drive shaft is of the Birfield joint (B.J.)-tripod joint (T.J.) type. This type features high power transmission efficiency and low vibration and noise. It has the following features.

- B.J.
- Large operating joint angle
 - Compact size and decreased space requirements
- T.J.
- Axially slidable
 - Smaller sliding friction
 - The B.J. joint boot is made of highly-durable resin to provide improved reliability

SPECIFICATIONS

Item	Specifications
Hub, knuckle	
Bearing type	Unit ball bearing
Drive shaft	
Joint type	Outer B.J. Inner T.J.
Length (between joints) x 0.D.	
	L.H. mm (in.) 419 x 26 (16.5 x 1.02)
	R.H. mm (in.) 391 x 26 (15.4 x 1.02)

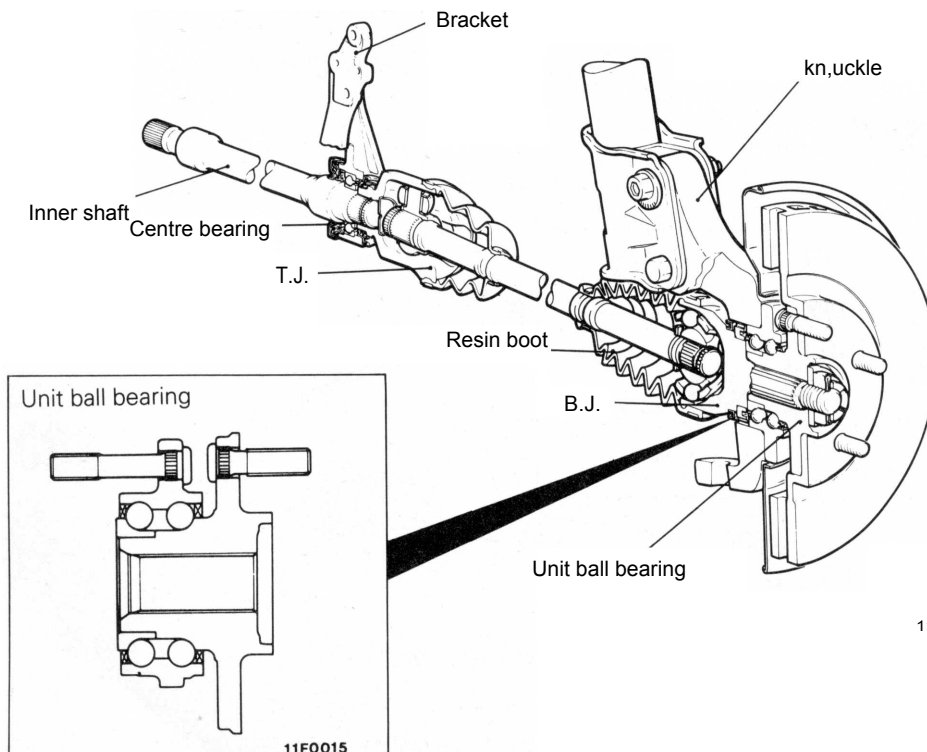

11F0048

REAR AXLE

The differential carrier and axle housing have been separated from each other, and T.J. and B.J. drive shafts arranged in between. They drive the axle shafts. The axle shaft is supported by ball bearings (inner and outer) in the axle housing and are coupled with the drive

shaft with the companion flange in between. The front of the differential carrier is supported elastically on the rear suspension crossmember via the differential support and the rear side via the differential support member.

SPECIFICATIONS

Items	Specifications
Axle shaft	
Type	Semi-floating type
Shaft dimensions	
Outer bearing portion dia.	mm (in.) 35 (1.38)
Inner bearing portion dia.	mm (in.) 28 (1.10)
Center portion dia.	mm (in.) 34.5 (1.36)
Overall length	mm (in.) 245.4 (9.7)
Bearing	
O.D. x I.D.	
Outer	mm (in.) 72 x 35 (2.83 x 1.38)
Inner	mm (in.) 58 x 28 (2.28 x 1.10)
Drive shaft	
Joint type	B.J.
Outer	T.J.
Inner	
Length (joint to joint) x diameter	mm (in.) 395 x 28 (15.6 x 1.10)
Differential	
Reduction gear type	Hypoid gear
Reduction ratio	3.545
Differential gear type and configuration	
Side gear	Straight bevel gear x 2*
Pinion gear	Straight bevel gear x 4
Number of teeth	
Drive gear	39
Drive pinion	11
Side gear	16
Pinion Gear	10
Bearing	
O.D. x I.D.	
Side	mm (in.) 82.500 x 45.242 (3.25 x 1.78)
Front	mm (in.) 68.263 x 30.163 (2.69 x 1.19)
Rear	mm (in.) 76.200 x 36.513 (3.00 x 1.44)
Final drive gear backlash adjustment method	Screw type

*. Denotes the gear (L.H.) which is in a single body with the viscous coupling.

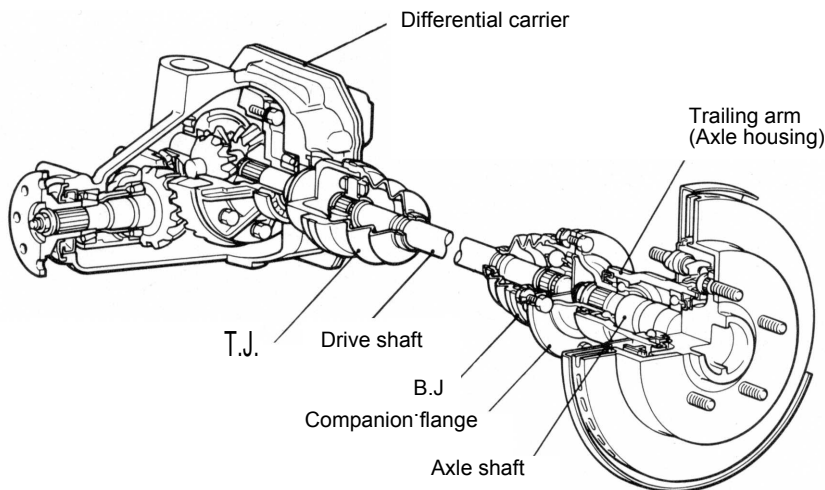

AXLE SHAFT

The axle shaft is a semi-floating type supported by ball bearings (outer and inner) in the housing. On models with the anti-lock braking system, there is a wheel speed sensing rotor on the axle shaft.

To prevent mud that may be deposited around the bearing (outer), a dust shield has been provided.

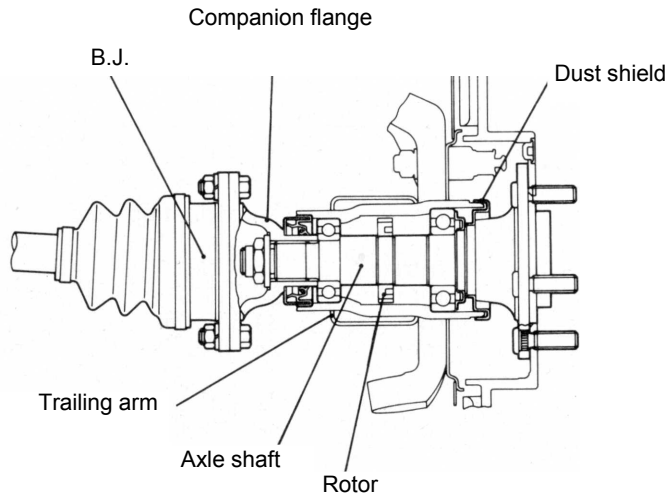

11N0009

DRIVE SHAFT

A B.J.-T.J. type constant velocity joint is used in the drive shaft, featuring the same good transmission efficiency, low vibration and low noise as the front drive shaft. On the axle shaft side there is a B.J. type joint that can bend to a great degree to match movement of the suspension and on the differential carrier side there is a T.J. type joint that can slide to a large amount in the shaft direction with little sliding friction.

On the axle shaft side, they are coupled with the companion flange in between. On the differential side, they are spline coupled with the side gears, the right and left drive shafts are different in length. In addition, the T.J. side of the drive shaft (R.H.) is two-stage serration coupled.

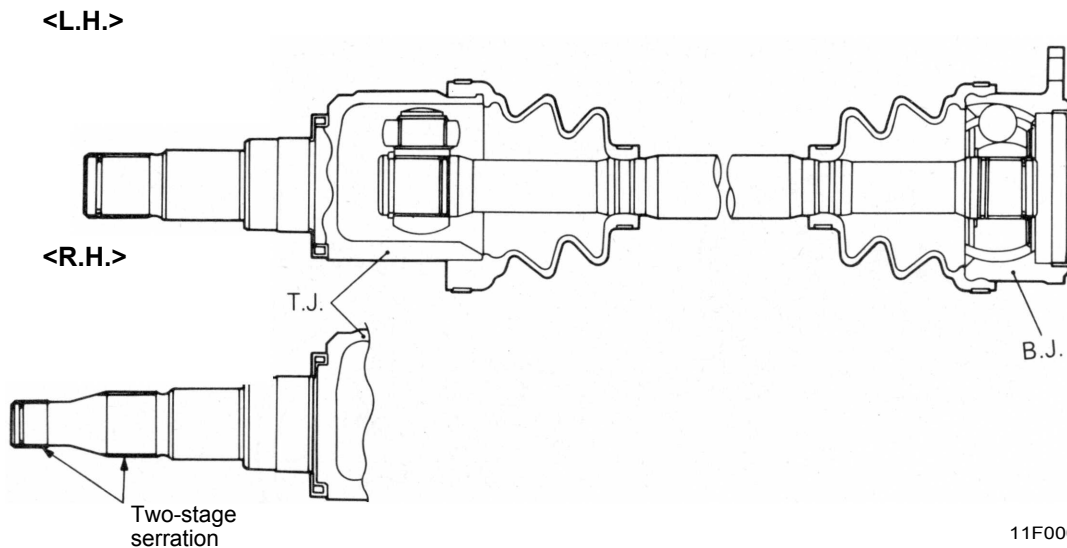

11F0006

DIFFERENTIAL

The differential uses lower friction torque bearings and oil seals to improve power performance and fuel consumption.

For faster differential cooling and higher reliability during high speed operation, a differential carrier with cooling fins has been adopted.

A speed difference responsive viscous coupling type

limited slip differential which provides outstanding performance during operation on a muddy surface has been established.

There is a 4-wheel steering (4WS) oil pump on the top of the differential carrier.

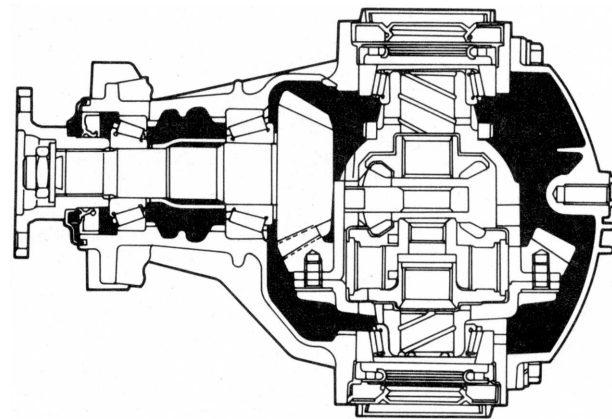
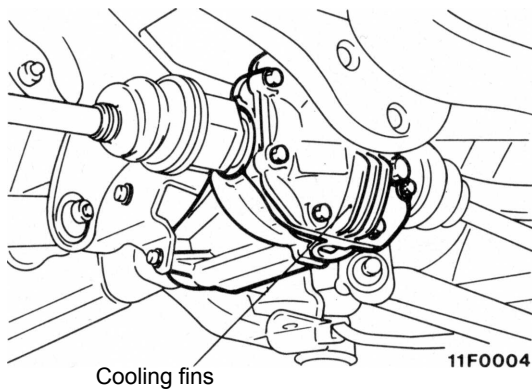

VISCOUS COUPLING TYPE LIMITED SLIP DIFFERENTIAL

While the conventional mechanical type limited slip differential uses a cam (differential pinion shaft) and disc equipment composed of a friction plate, disc and spring seat in limiting the differential, the viscous

coupling type limited slip differential limits the differential by use of a viscous coupling equipment consisting of outer and inner plates and silicone oil.

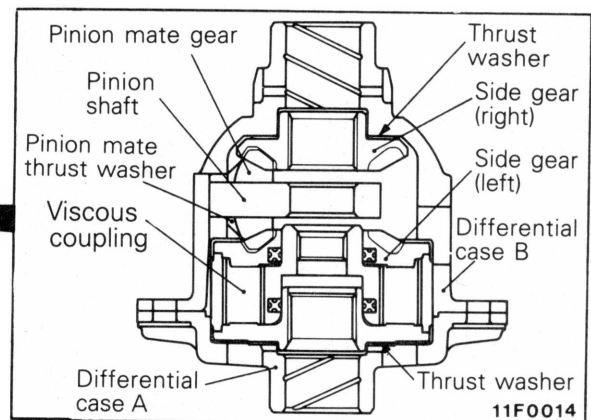
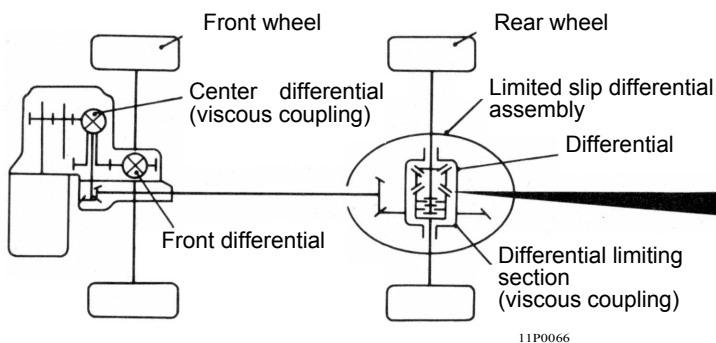

DIFFERENTIAL SUPPORT

The front and rear of the differential carrier are mounted on the suspension crossmember by the differential

supports and differential support member. It is elastically mounted via a bushing.

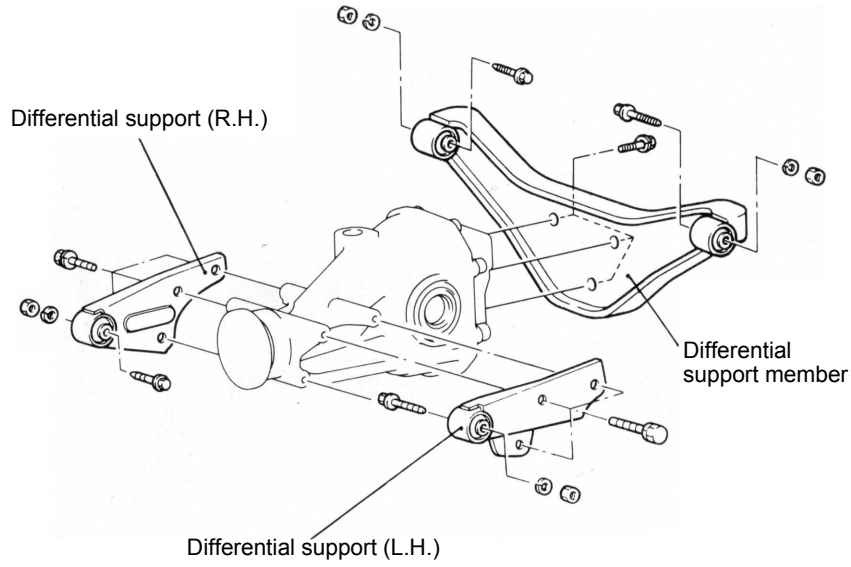

11N0038

DRIVE-CONTROL COMPONENTS

CONTENTS

SUSPENSION	2	4 WHEEL STEERING (4WS) SYSTEM	27
Features	2	Specifications	27
FRONT SUSPENSION	3	System Construction	28
Features	3	Rear Wheel Steering Oil Pump,	29
Specifications	3	Control Valve	29
Camber Adjustment Mechanism	4	Power Cylinder	29
REAR SUSPENSION	5	BRAKES	30
Features	5	Features	30
Specifications	5	SERVICE BRAKES	31
Crossmember and Crossmember		Specifications	31
Support Bushing	6	Front Disc Brake	32
ELECTRONIC CONTROL SUSPENSION		Rear Disc Brake	33
(ECS)	7	ANTI-LOCK BRAKE SYSTEM (ABS)	34
Specifications	7	System Drawing	35
Main Parts and Their Functions	9	ABS Electric Diagram	36
System Block Diagram	9	ABS Hydraulic Function Drawing	37
Features of Each Mode	10	Sensor	38
Features of Each Control	10	Actuator	38
Structure and Operation	11	Electronic Control Unit (ECU)	39
WHEEL AND TYPE	21	PARKING BRAKE	41
Specifications	21		
POWER STEERING	22		
Specifications	22		
Steering Wheel and Column	23		
Oil Pump	26		

SUSPENSION

A 4 wheel independent suspension system has been adopted, with the front suspension of a MacPherson strut type, and the rear suspension of a double

wishbone type. In addition, 4WS is equipped in all models.

FEATURES

Improved steering stability and riding comfort

1. Adoption of electronic control suspension (ECS)
2. Adoption of 4 wheel independent suspension
3. Adoption of wide tread tyres
4. Optimization of suspension geometry
5. Adoption of pillow ball type stabilizer links
6. Optimization of spring characteristics of suspension bushing
7. Adoption of a liquid filled bushing as the front suspension lower arm bushing

Improved riding comfort

1. Adoption of double elastic supported suspension members
2. Optimization of coil spring offset amount
3. Adoption of large-sized bump rubber

Improved serviceability

1. Full realization of self-diagnosis for ECS system
2. Adoption of a camber adjustment mechanism in the front suspension
3. Adoption of camber and toe-in adjustment mechanisms in the rear suspension

FRONT SUSPENSION

Perimeter type (crossed parallel) suspension members are used in the front suspension to improve driving stability.

FEATURES

- Reduction of vibration and noise because the entire suspension system is elastically supported by rubber bushings.
- Ideal wheel alignment for superior driving stability and riding comfort.
- Adoption of anti-driving geometry for outstanding driving stability.
- Adoption of negative offset geometry for outstanding braking stability.
- Offset coil springs for outstanding riding comfort.
- Improved serviceability due to the adoption of a camber adjustment mechanism.

SPECIFICATIONS

Items	Specifications
Suspension system	MacPherson strut with coil spring and compression rod type
Camber	0° ± 30'
Caster	3°55' ± 30'
Toe-in	mm (in.) 0 ± 3 (0 ± 0.12)
Coil spring	
Wire dia x O.D. x free length	mm (in.)
Vehicles for Europe	15.4 x 185.4 x 293 (0.61 x 7.30 x 11.54)
Vehicles for General Export, GCC and Australia	15.7 x 185.7 x 301.5 (0.62 x 7.31 x 11.87)
Coil spring identification colour	
Vehicles for Europe	Pink x 2
Vehicles for General Export, GCC and Australia	Blue x 1
Spring constant	N/mm (kg / mm, lbs. / in.) 39 (3.9, 218)
Shock absorber	
Type	Hydraulic, cylindrical double acting type
Stroke	mm (in.) 150 (5.91)
Damping force [at 0.3 m/sec. (0.984 ft./sec)]	
Expansion	N (kg, lbs.) Hard: 2,650 (265, 584) Medium: 1,650 (165, 363) Soft: 650 (65, 143)
Contraction	N (kg, lbs.) Hard: 1,200 (120, 265) Medium: 1,150 (115, 253) Soft: 1,000 (100, 220)
Stabilizer bar	
Mounting method	Pillow ball type
O.D.	mm (in.) 23 (0.91)

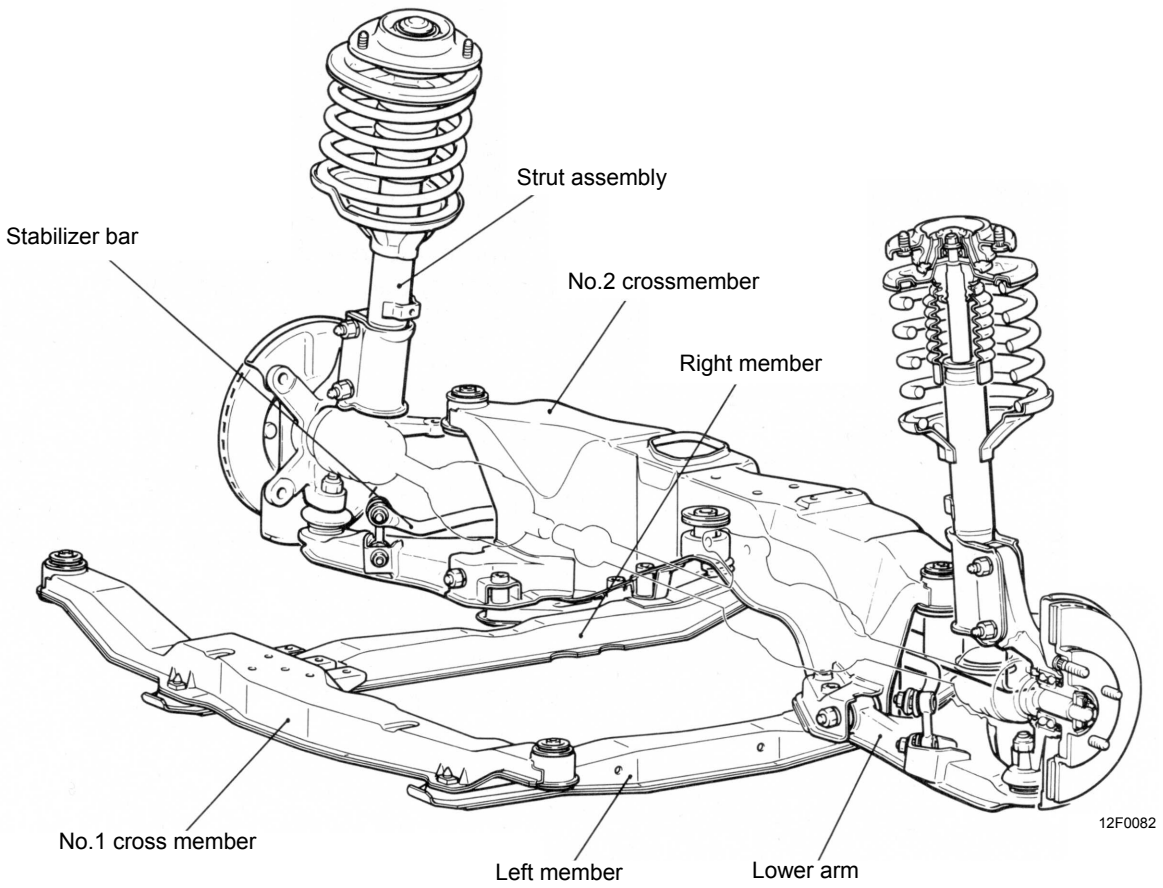

CAMBER ADJUSTMENT MECHANISM

It is possible to adjust the camber by turning the strut lower mounting bolt.

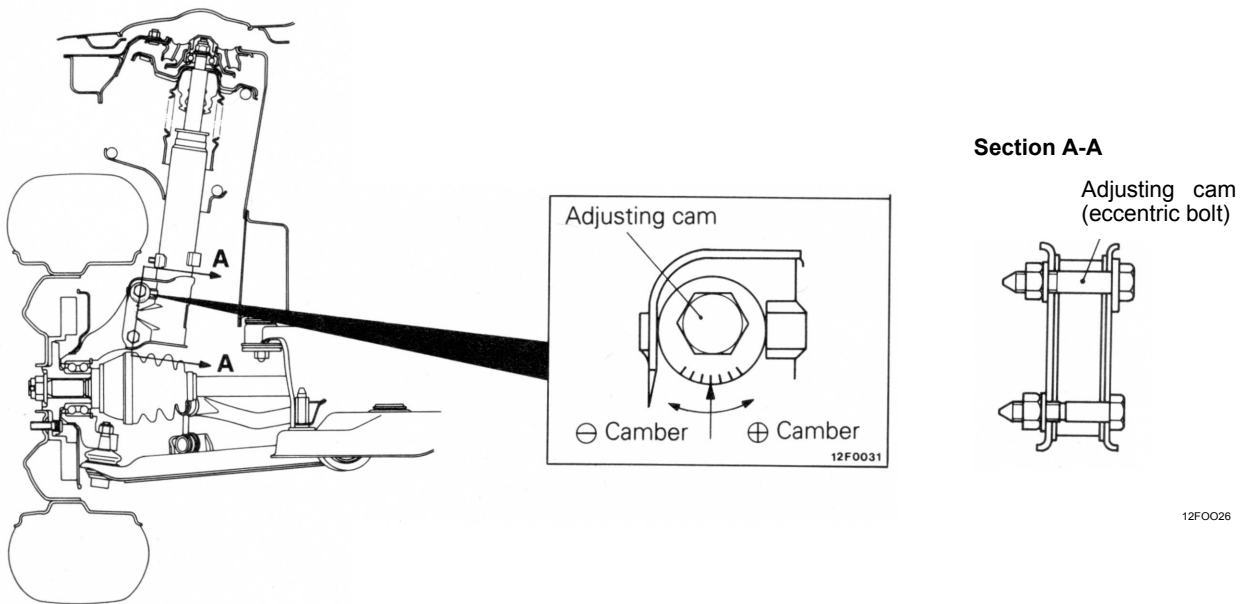

REAR SUSPENSION

FEATURES

- Independent suspension for sure grip on the ground.
- Arm arrangement to minimized camber variations against the ground.
- Low friction design that does not put bending force on the damper.
- Anti-lift geometry to control tail lifting when braking.
- Improved quietness due to differential carrier double elastic support structure.

SPECIFICATIONS

Items	Specifications
Suspension system	Double-wishbone type
Camber	-0° 10' ± 30'
Toe-in mm (in.)	0.5 ± 2.5 (0.02 ± 0.10)
Coil spring	
Wire dia. x O.D. x free length mm (in.)	12.2 x 117.2 x 379.3 (0.48 x 4.61 x 14.93)
Coil spring identification colour	Blue x 2
Spring constant N/mm (kg / mm, lbs. / in.)	28.0 (2.8, 157)
Shock absorber	
Type	Hydraulic, cylindrical double-acting type
Stroke mm (in.)	203 (8.0)
Damping force [at 0.3 m/sec. (0.984 ft./sec.)]	
Expansion N (kg, lbs.)	Hard: 1,710 (171,377) Medium: 1,160 (116, 256) Soft: 560 (56, 123)
Contraction N (kg, lbs.)	Hard: 1,010 (101, 223) Medium: 880 (88, 194) Soft: 670 (67, 148)
Stabilizer bar	
Mounting method	Pillow ball type
O.D. mm (in.)	22 (0.86)

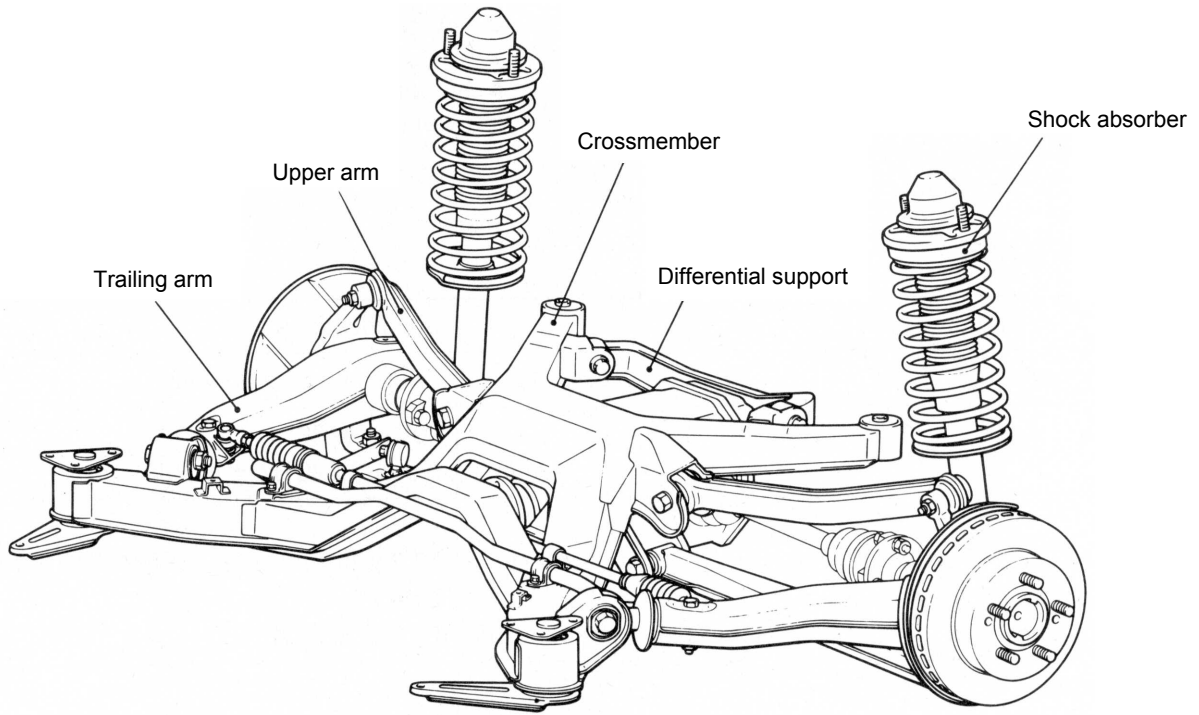

12F0105

CROSSMEMBER AND CROSSMEMBER SUPPORT BUSHING

The crossmember not only receives input from each arm and link as a real suspension crossmember but also supports the rear differential.

The crossmember support bushing provides better isolation of high frequency noise such as noise from the differential and gears by using inter-mass to shift resonance.

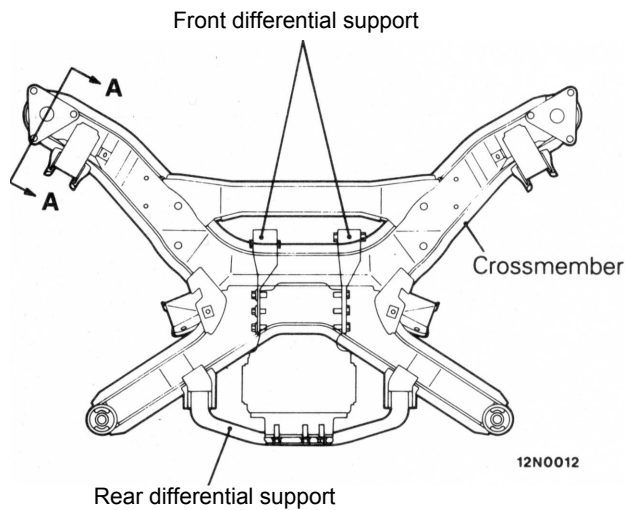

12N0014

12N0012

ELECTRONIC CONTROL SUSPENSION (ECS)

The electronic control suspension (ECS) is a system that automatically switches the damping force characteristics of the four shock absorbers, front and rear, in three steps (SOFT, MEDIUM and HARD) in response to driving conditions and the conditions of the road surface. It is also possible to select two modes (TOUR and SPORT) according to driver preference. The damping

force is changed by commands from the ECS control unit; the actuator built into the shock absorbers is activated and the flow of oil inside the absorbers is varied.

This system also has a diagnostic function and a failsafe function for improved serviceability and safety.

SPECIFICATIONS

FRONT SUSPENSION

Items	Specifications
Suspension system	MacPherson strut with coil spring and compression rod type
Camber	0° ± 30'
Caster	3°55' ± 30'
Toe-in	mm (in.) 0 ± 3 (0 ± 0.12)
Coil spring	
Wire dia. x O.D. x free length	mm (in.)
Vehicles for Europe	15.4 x 185.4 x 293 (0.61 x 7.30 x 11.54)
Vehicles for General Export, GCC and Australia	15.7 x 185.7 x 301.5 (0.62 x 7.31 x 11.87)
Coil spring identification colour	
Vehicles for Europe	Pink x 2
Vehicles for General Export, GCC and Australia	Blue x 1
Spring constant	N/mm (kg/mm, lbs./in.) 39 (3.9, 218)
Shock absorber	
Type	Hydraulic, cylindrical double acting type
Stroke	mm (in.) 150 (5.91)
Damping force [at 0.3 m/sec. (0.984 ft./sec.)]	
Expansion	N (kg, lbs.)
Hard	2,650 (265, 584)
Medium	1,650 (165, 363)
Soft	650 (65, 143)
Contraction	N (kg, lbs.)
Hard	1,200 (120, 265)
Medium	1,150 (115, 253)
Soft	1,000 (100, 220)
Stabilizer bar	
Mounting method	Pillow ball type
O.D.	mm (in.) 23 (0.91)

3-8 DRIVE-CONTROL COMPONENTS - Electronic Control Suspension (ECS)

REAR SUSPENSION

Items	Specifications
Suspension system	Double-wishbone type
Camber	-0° 10' ± 30'
Toe-in	mm (in.) 0.5 ± 2.5 (0.02 ± 0.10)
Coil spring	
Wire dia. x O.D. x free length	mm (in.) 12.2 x 117.2 x 379.3 (0.48 x 4.61 x 14.93)
Coil spring identification colour	Blue x 2
Spring constant	N/mm (kg/mm, lbs./in.) 28.0 (2.8, 157)
Shock absorber	
Type	Hydraulic, cylindrical double-acting type
Stroke	mm (in.) 203 (8.0)
Damping force [at 0.3 m/sec. (0.984 ft./sec.)]	
Expansion	N (kg, lbs.) Hard: 1,710 (171, 377) Medium: 1,160 (116, 256) Soft: 560 (56, 123)
Contraction	N (kg, lbs.) Hard: 1,010 (101, 223) Medium: 880 (88, 194) Soft: 670 (67, 148)
Stabilizer bar	
Mounting method	Pillow ball type
O.D.	mm (in.) 22 (0.86)

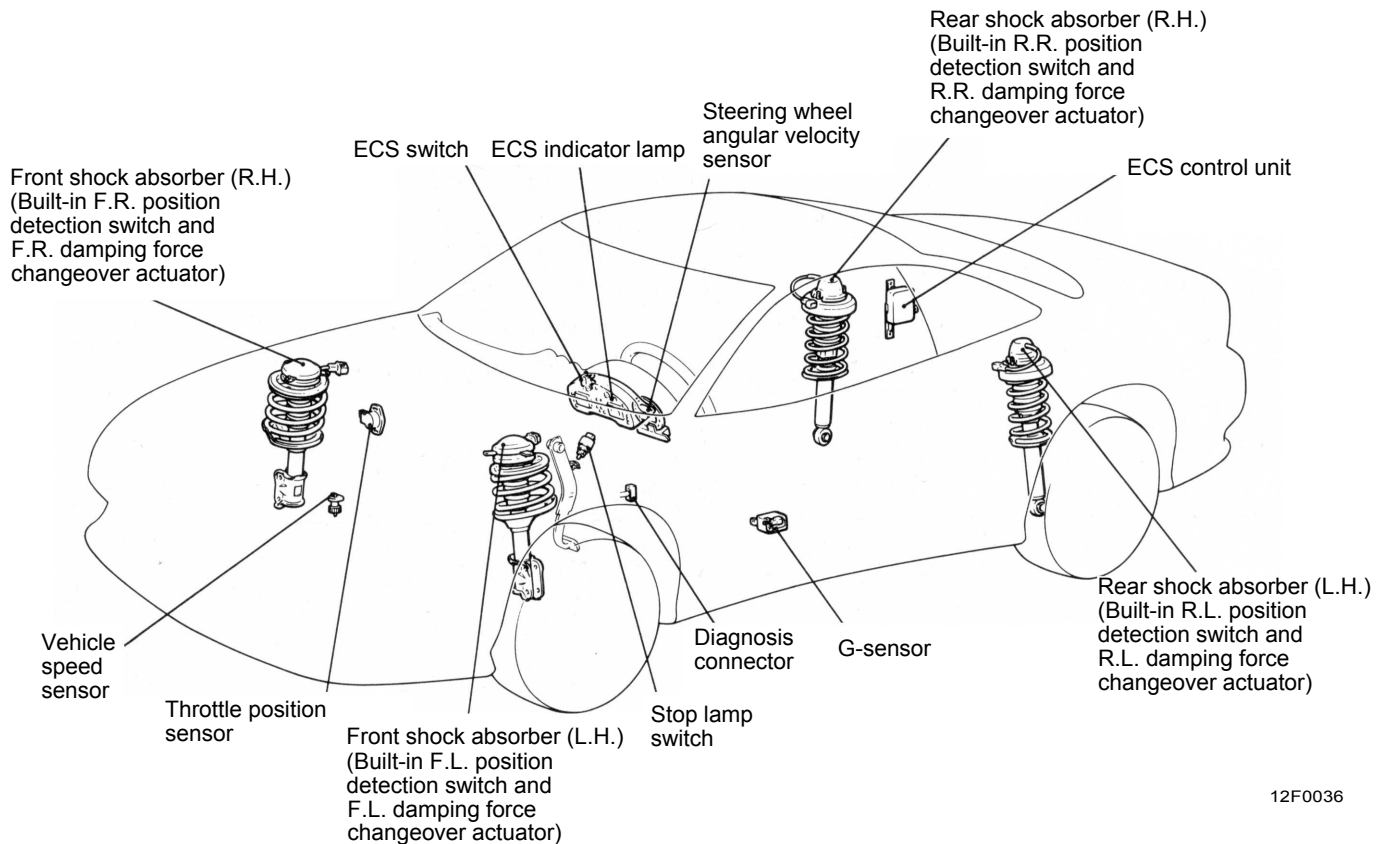

MAIN PARTS AND THEIR FUNCTIONS

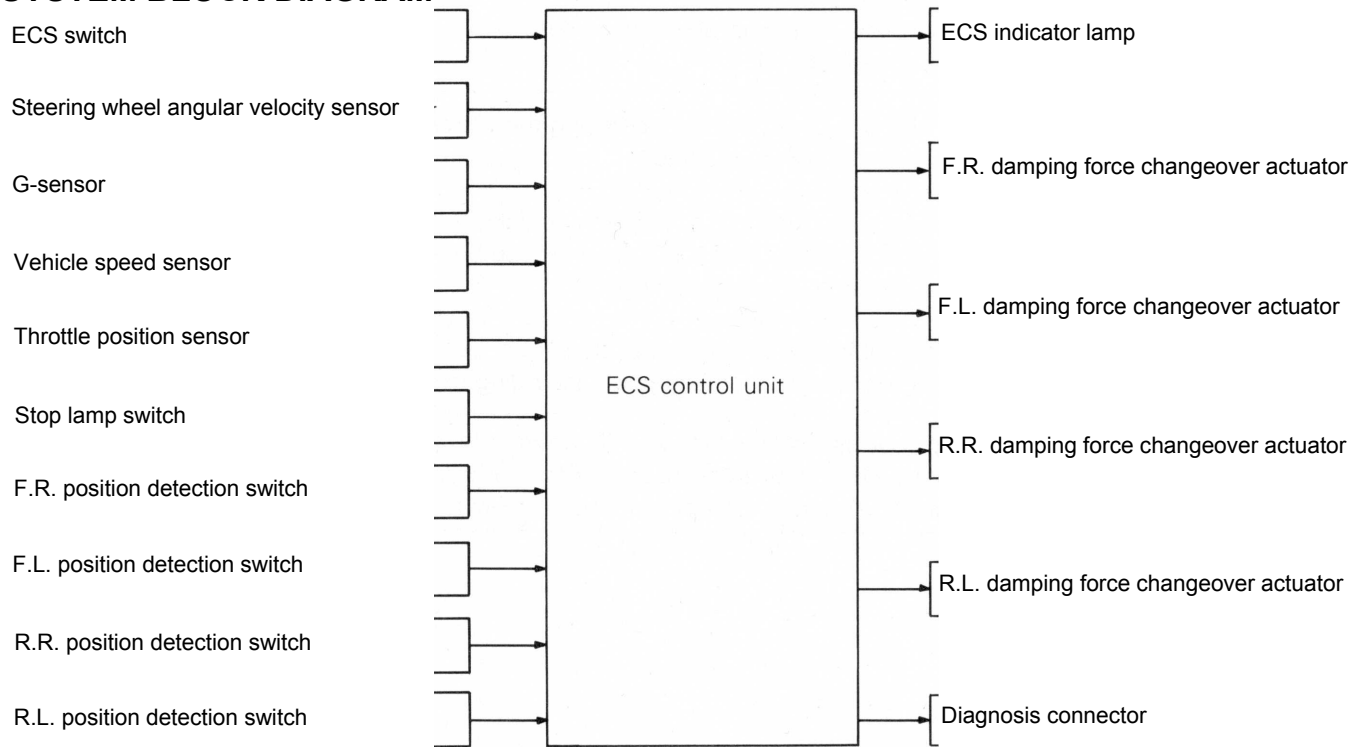

Parts	Function	Mounting position
Sensor ECS switch Steering wheel angular velocity sensor G-sensor Vehicle speed sensor Throttle position sensor Stop lamp switch Position detection switch	Control mode selection switch Detects turning direction and angular velocity of steering wheel Detects up/down vibration of vehicle Detects speed of vehicle Detects throttle opening Detects condition of brake pedal Detects damping conditions of shock absorbers	Meter bezel Column switch Under front seat (LH) Transmission case Throttle body Brake pedal bracket Built in shock absorber (x 4)
Actuator ECS indicator lamp Damping force changeover actuator ECS control unit Diagnosis connector	Indicates control mode Orifice changeover of inside of shock absorber System control Output of safe diagnosis code	Inside combination meter Built in shock absorber (x 4) Right side of luggage compartment Side of junction block

SYSTEM BLOCK DIAGRAM



3-10 DRIVE-CONTROL COMPONENTS - Electronic Control Suspension (ECS)

FEATURES OF EACH MODE

Mode	ECS indicator light	Damping force	Features
TOUR		Automatic selection depending on driving conditions SOFT MEDIUM- HARD	<ul style="list-style-type: none"> • Normal damping force with emphasis on a comfortable ride (SOFT) • Safe operation control when making sudden turns or during high speed. • Vehicle position control when starting and braking • Comfortable riding control when there is up/down vibration of the vehicle and when driving on bad roads is detected
SPORT		Normally fixed in high damping force (HARD)	<ul style="list-style-type: none"> • Ideal mode for sporty driving • Normally high damping force with emphasis on safe operation and stability (HARD)

FEATURES OF EACH CONTROL

Control function		Feature
Safe operation control	Anti-rolling control	Rolling when going into a curve is controlled and safe operation is improved by increasing the shock absorber damping force according to the steering wheel angular velocity and vehicle speed.
	High speed control	Operation safety is improved by increasing the shock absorber damping force when driving at high speed.
Position control	Anti-diving control	Nose diving is controlled by increasing the shock absorber damping force depending on deceleration when braking.
	Anti-squatting control	Squatting when starting, accelerating quickly, etc. is controlled by increasing the shock absorber damping force according to how far the accelerator pedal is pressed and according to the vehicle speed.
Comfortable ride control	Pitching and bouncing control	A comfortable ride with little car pitching or bouncing is made possible by increasing the shock absorber damping force according to the up/down vibration of the vehicle.
	Bad road detection control	A bad road is detected by the up/down vibration of the vehicle, and a comfortable ride and bad road driving is improved by intentionally maintaining the shock absorber damping force soft or medium.

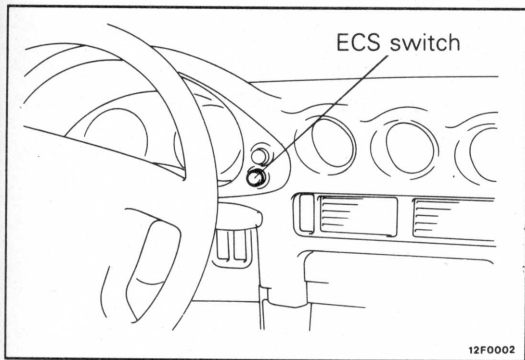

STRUCTURE AND OPERATION

SENSOR

ECS Switch

The ECS switch is a return type switch mounted on the meter bezel.

When the battery is connected and the ignition switch turned ON, it starts in the TOUR mode. Then, it changes between the TOUR and SPORT mode each time the mode changeover switch is pressed.

Steering Wheel Angular Velocity Sensor

The steering wheel angular velocity sensor is made up of 2 photo interrupters and a slit plate. The photo interrupters are mounted on the column switch and the slit plate is mounted on the steering shaft. The slit plate rotates between the photo interrupters so the light from the LED of photo interrupter is interrupted and passed through and that is changed by the photo diode to an electric signal according to the steering wheel angular velocity.

Furthermore, the steering turning direction can also be detected by the divergence in each 1/4 cycle of the output wave of the photo interrupters.

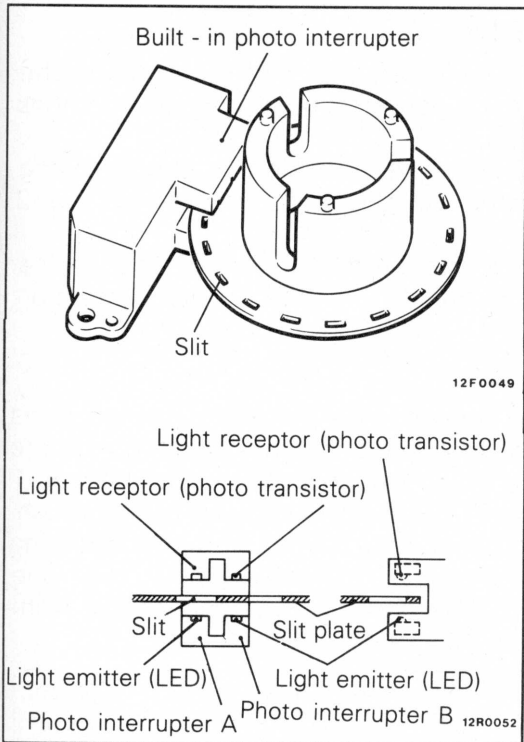

G-Sensor

The G-sensor detects the up/down vibration of the vehicle and outputs an electric signal. This sensor is used for controlling a comfortable ride, and it is mounted under the front seat (LH) where it can accurately detect the up/down vibration felt by the driver.

The inside of the G-sensor are made up of a piezoelectric ceramic and a weight. The weight adds extra force on the piezoelectric ceramic depending on the up/down vibration and the G-sensor outputs an electric signal according to the vibration due to the piezoelectric effect.

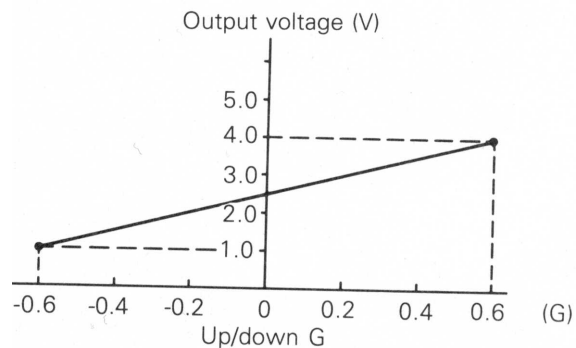
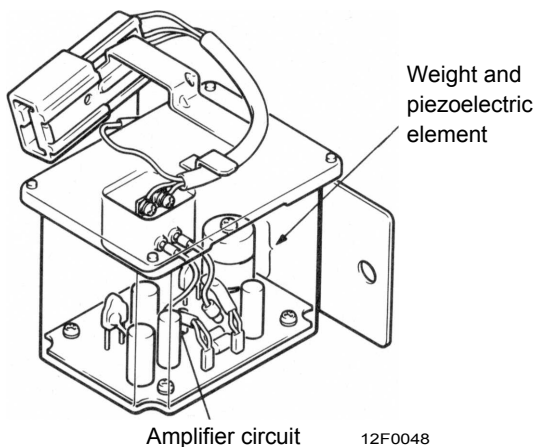

G-sensor output characteristics

12F0003

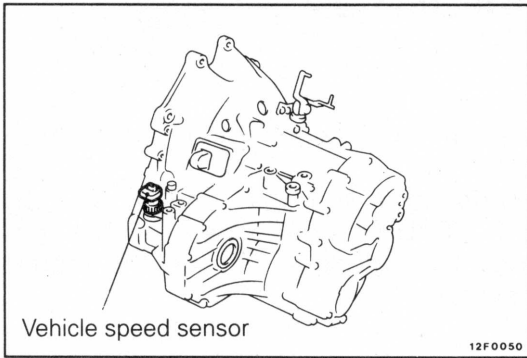

Vehicle Speed Sensor

The vehicle speed sensor is mounted directly onto the transmission. For the structure of the vehicle speed sensor, refer to GROUP 7 - Meters and Gauges.

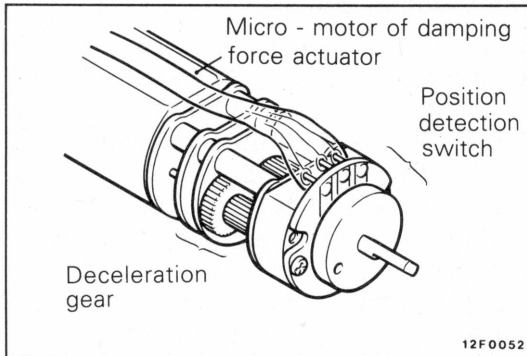

Position Detection Switch

The position detection switches are combined with the damping force changeover actuator built into each shock absorber. It detects the orifice changeover position of the damping force changeover actuator by the combination of the 2 switches (ON/OFF).

The control unit controls the stop position of the orifice changeover based on the signal from this position detection switch.

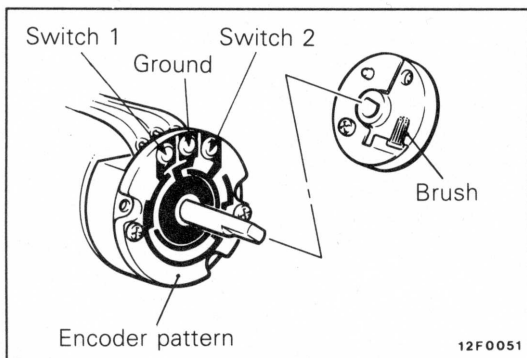

The inside structure of the position detection switch is as shown in the figure on the left and it is made up of the encoder pattern and the brush rotating above it. Switches 1 and 2 are turned ON and OFF by the rotations of the brush. The relation between the switch output and the damping force characteristics is shown in the table below. For one revolution of the switch, the damping force changes from SOFT → HARD → MEDIUM → HARD → (unfixed)

Damping force	SOFT	HARD	MEDIUM	HARD	(unfixed)
Switch 1	ON	OFF	ON	OFF	OFF
Switch 2	OFF	ON	ON	ON	OFF

Rotation angle 0°

360°

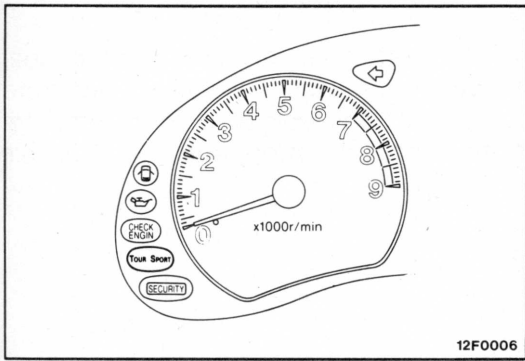

ACTUATOR

ECS Indicator Lamp

There is an indicator lamp (green) to indicate the mode in the combination meter. When a breakdown is detected, it flashes at intervals of 0.5 second to warn the driver.

Mode	TOUR	SPORT	When breakdown
TOUR lamp	ON	OFF	Flashing
SPORT lamp	OFF	ON	Flashing

Damping Force Changeover Actuator

The damping force changeover actuator is built into the front and rear shock absorbers and designed for compactness, lightweight and reduction of mounting space. It is made up of the micro-motor section, deceleration gear section, position detection switch

section and output shaft. The output shaft has a high torque output because the high revolutions of the micro-motor are reduced by the deceleration gear.

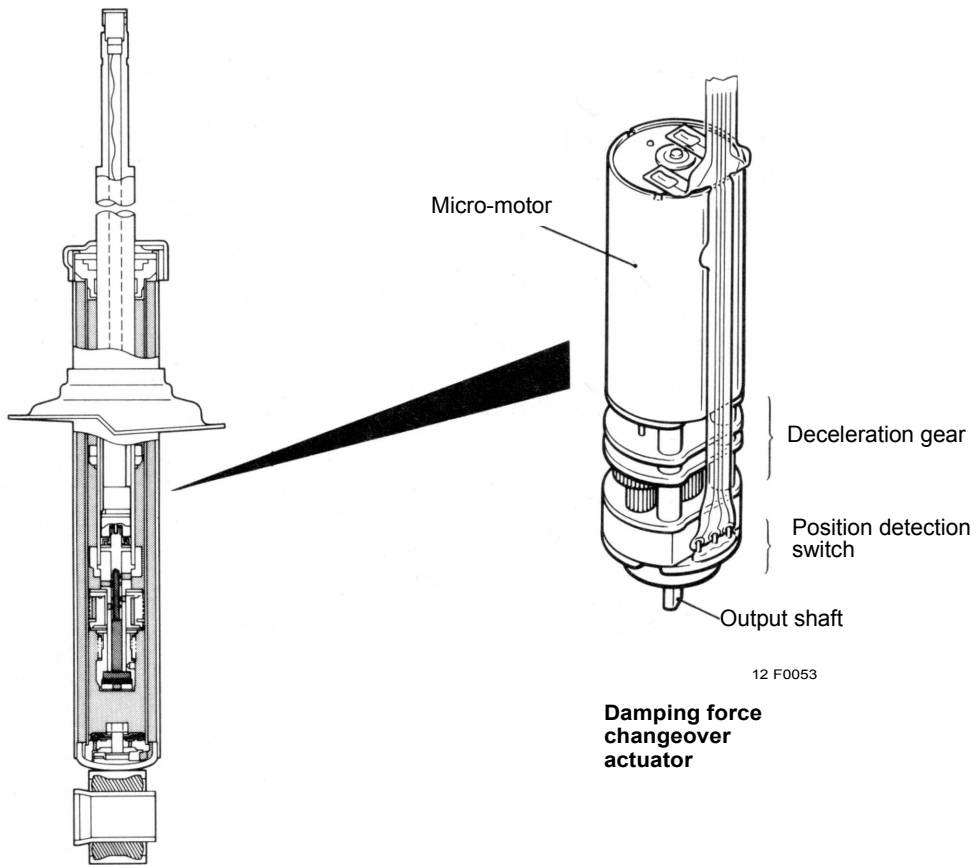

12F0004

12 F0053

Damping force changeover actuator

3-14 DRIVE-CONTROL COMPONENTS - Electronic Control Suspension (ECS)

SHOCK ABSORBER

The shock absorber comes with a built in damping force changeover actuator (including a position detection switch) and the damping force can be changed in 3 steps (SOFT, MEDIUM and HARD) with this actuator.

Furthermore, the piston valve has a double seat and the base valve is made of 2 valves; accurate control is possible at any damping force step for achieving both safe operation and comfortable riding.

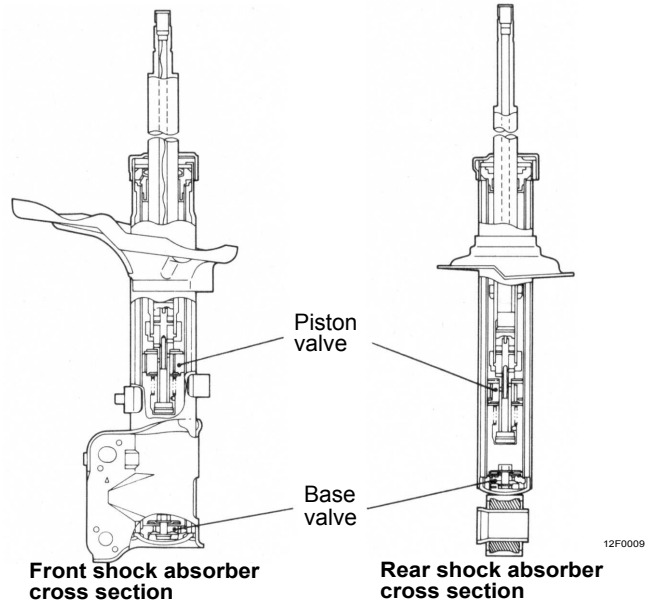
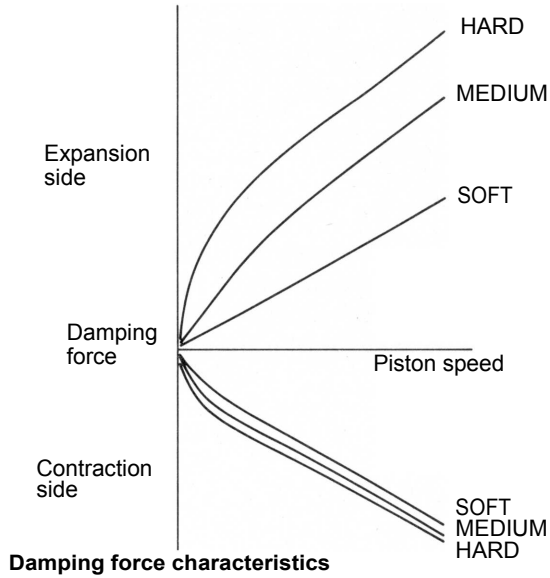

Damping Force Changeover Mechanism

For damping force changeover, the damping force changeover actuator is operated by a signal from the control unit which causes the rotary valve built into the piston rod to rotate and changes the opening/closing of the orifice and the oil flow passage area. The rotary valve has large and small orifices (1 each for a total of 8) as shown in the cross sections A-A, B-B, C-C, and D-D in the figure below. There is also one passage (for a total of 4) for each cross section in the piston rod.

The damping force is changed in 3 steps by combining the rotary valve and piston rod passages. When the ECS control unit confirms the change in the damping force by the command from the position detection switch, it stops the signal sent to operate the damping force changeover actuator.

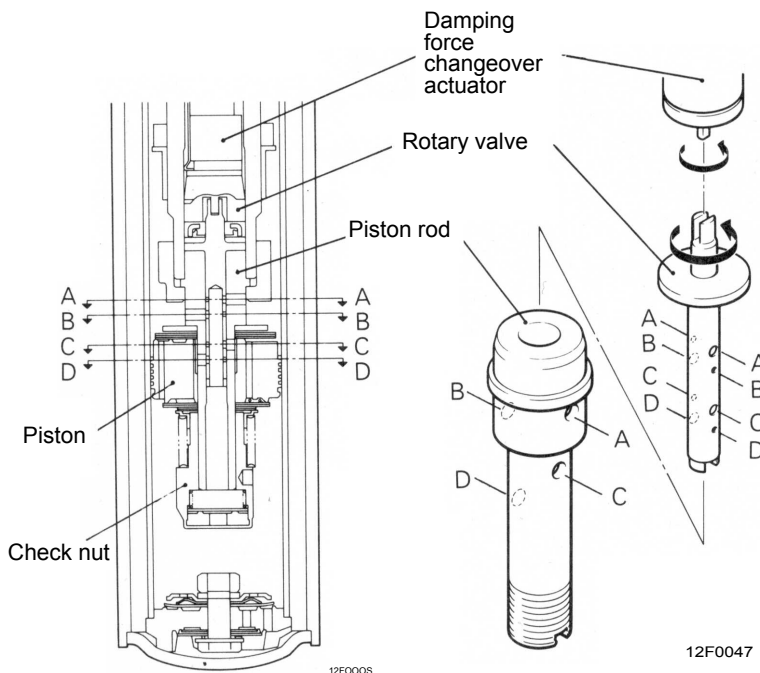

	Damping Force		
	SOFT	MEDIUM	HARD
Cross section A-A	Orifice (large dia.) 	Orifice (small dia.) 	Orifice (closed)
Cross section B-B	Orifice (large dia.) 	Orifice (small dia.) 	Orifice (closed)
Cross section C-C	Orifice (large dia.) 	Orifice (small dia.) 	Orifice (closed)
Cross section D-D	Orifice (large dia.) 	Orifice (small dia.) 	Orifice (closed)

12F0008

12F0047

12F0037

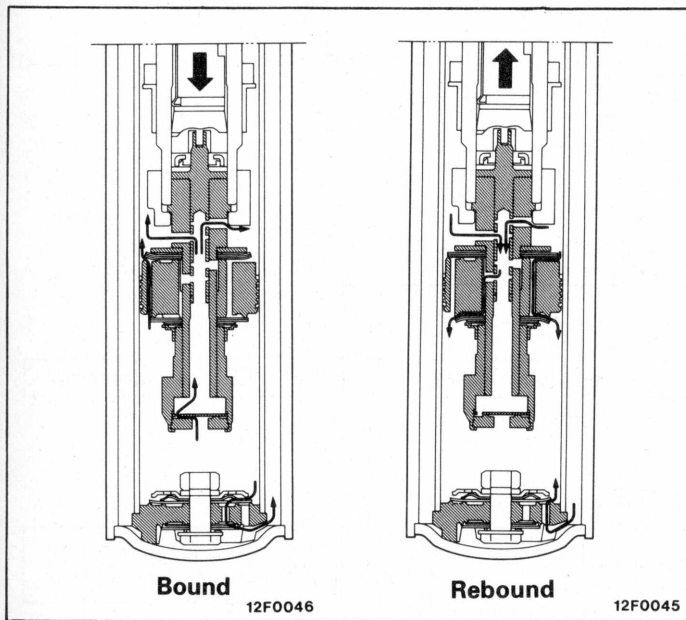

Internal Operation of Shock Absorber

SOFT (low damping force)

When bounding

The damping force is determined mainly by the flow resistance on the base valve side and a low damping force is obtained by passing oil in the lower part of the piston through the check valve built into the check nut and the orifice (large dia.) with no resistance.

When rebounding

As the piston rod rises, oil flows as shown in the figure on the left and the damping force is determined by the flow resistance of the piston valve.

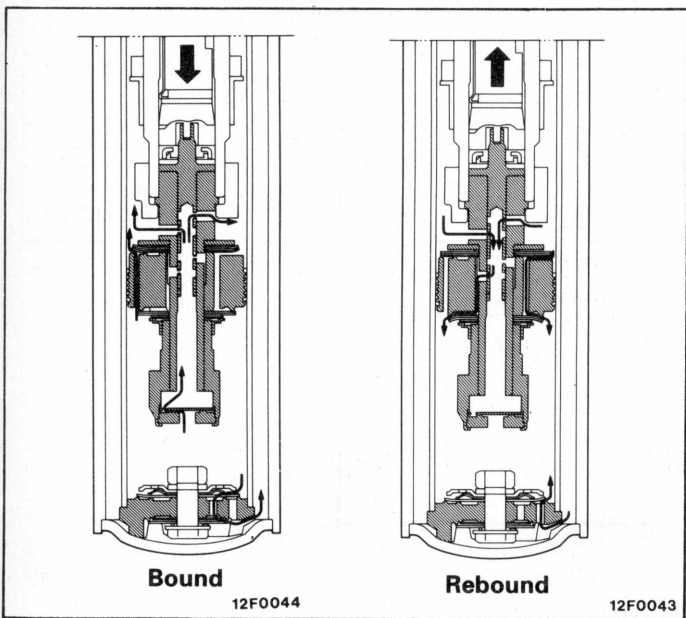

MEDIUM (medium damping force)

When bounding

Compared to SOFT damping force, the orifice diameter is smaller, piston rod flow resistance increases and the damping force is the force combined with the flow resistance on the base valve side.

When rebounding

The orifice diameter is smaller just as when bounding and a higher damping force than at SOFT is obtained.

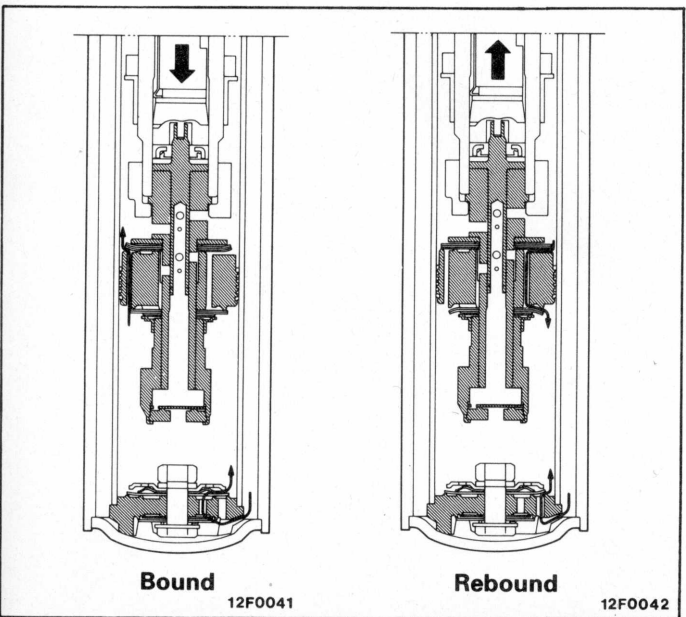

HARD (high damping force)

When bounding

Since the orifice is closed, oil in the lower part of the piston pushes wide the valve in the upper part of the piston and flows out so flow resistance increases and a higher damping force than at MEDIUM is obtained.

When rebounding

This is the same as when bounding. Since the orifice is closed, damping force is at its maximum.

3-16 DRIVE-CONTROL COMPONENTS - Electronic Control Suspension (ECS)

ECS CONTROL UNIT

The ECS control unit is mounted on the inside of the rear side trim. The ECS control unit sends a signal to the damping force changeover actuator to simultaneously

change the damping force of the 4 shock absorbers.

Structure

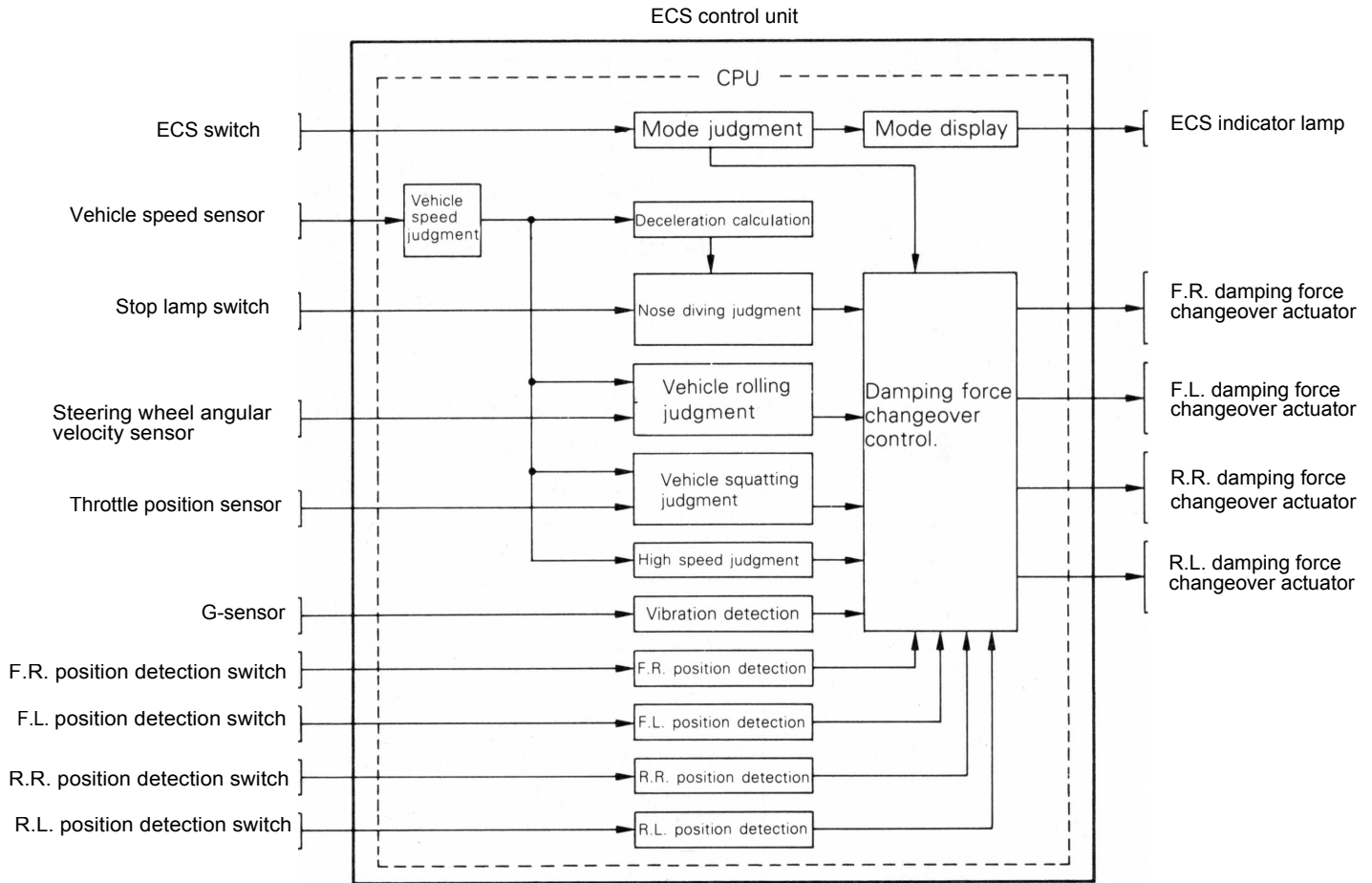

Function Chart

Control function		Control	Related sensor	Damping force mode	
				TOUR	SPORT
Selection of control mode		Selects 2 modes (TOUR and SPORT) by input from the ECS switch	ECS switch	—	—
Safe operation control	Anti-rolling control	Changes the damping force using map (steering wheel angular velocity to the vehicle speed) to control rolling when going into a corner and also to improve safe operation.	Steering wheel angular velocity sensor Vehicle speed sensor	(S) (M) (H)	(H)
	High speed response control	Changes the damping force according to speed when driving at high speed to improve operation safety.	Vehicle speed sensor	(S) (M)	(H)
Position control	Anti-diving control	After the stop lamp switch goes ON, it calculates the deceleration from the vehicle speed and changes the damping force in accordance with that to control nose diving.	Stop lamp switch Vehicle speed sensor	(S) (M) (H)	(H)
	Anti-squatting control	Changes the damping force using map (throttle opening (closing) speed to the vehicle speed) to control squatting when starting and accelerating.	Throttle position sensor Vehicle speed sensor	(S) (M) (H)	(H)
Riding comfort control	Pitching/bouncing control	Changes the damping force according to the up/down vibration of the vehicle to control pitching and bouncing of the vehicle.	G-sensor	(S) (H)	(H)
	Bad road detection control	Suppresses the damping force according to the up/down vibration of the vehicle to improve driving on bad roads and driving comfort.	G-sensor	(S) (M)	(H)
Fail-safe and diagnosis		It functions on the fail-safe side when there is a breakdown and outputs a self-diagnosis code.	—	—	

S: SOFT M: MEDIUM H: HARD

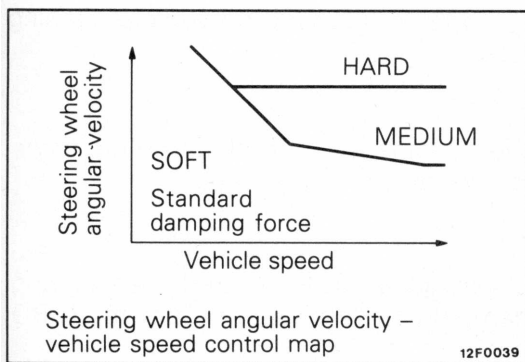

Anti-Rolling Control

CONTROL START

Change to a higher damping force according to the control map for the vehicle speed and steering wheel angular velocity which depends on the operation of the steering wheel.

CONTROL HOLD

After switching to a high damping force and holding that condition for 1 second, return to normal damping force (SOFT).

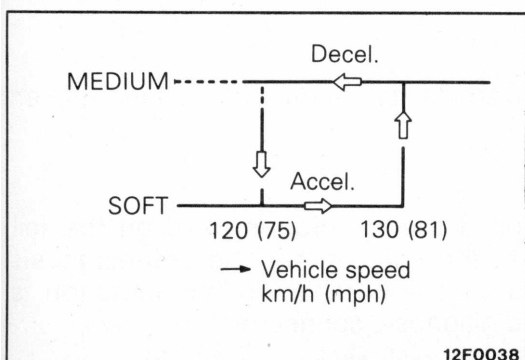

High Speed Response Control

CONTROL START

When vehicle speed exceeds 130km/h (81 mph) in the TOUR mode, the damping force changes from SOFT to MEDIUM to improve high speed stability.

CONTROL HOLD

Damping force which is changed to MEDIUM is held while the vehicle speed is over 120km/h (75 mph) but when it falls to 120km/h (75 mph), the damping force returns to SOFT.

3-18 DRIVE-CONTROL COMPONENTS - Electronic Control Suspension (ECS)

Anti-Diving Control

CONTROL START

When the stop light switch goes ON, the ECS control unit calculates deceleration from the change in vehicle speed. As a result, after the stop light goes ON, if deceleration calculated within 0.4 sec. exceeds 0.15G, the shock absorber damping force is changed to MEDIUM.

If the stop light switch is ON and the computed degree

of deceleration exceeds 0.4G, there will be a change to HARD.

CONTROL HOLD

The damping force after changeover is held while calculated deceleration is over 0.15G and when it falls below 0.15G, the damping force returns to normal (SOFT).

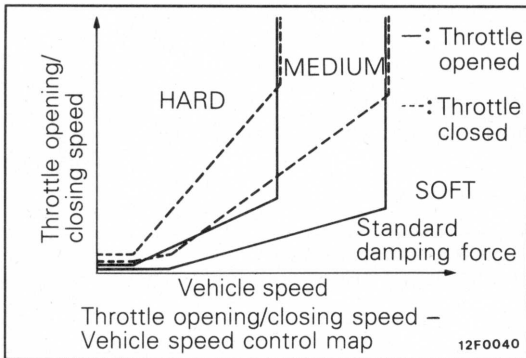

Anti-Squatting Control

CONTROL START

When the accelerator pedal is pressed (returned), it changes to a higher damping force through map control of the vehicle speed and speed change in throttle opening (closing).

There are 2 control maps - when the accelerator pedal is pressed and when it is returned (throttle opened and closed). Furthermore, when the throttle position sensor output voltage stays over 4.0V for more than 1 second at vehicle speed of 3 - 100km/h (2 - 62 mph), it is judged that there is full throttle acceleration and the damping force is switched to MEDIUM.

CONTROL HOLD

After changing from a high damping force, there is first a 1 second hold in that condition and then the suspension reverts to the normal damping force (SOFT).

When full throttle acceleration is judged, the suspension reverts to the normal damping force (SOFT) in one second after the control conditions are not satisfied.

Pitching/Bouncing Control

CONTROL START

When the ECS control unit judges that there is serious pitching and bouncing of the vehicle (washboard road driving) via the output of the G-

CONTROL HOLD

When the ECS control unit judges that there is no more pitching and bouncing of the vehicle via the output of the

sensor, the damping force is changed to HARD for a flat and comfortable ride with no vehicle pitching and bouncing.

G-sensor, normal damping force (SOFT) takes over at the same time.

Bad Road Response Control

When the ECS control unit judges that there is fine pitching and bouncing of the vehicle (bad road such as gravel road, etc.) via the output of the G-sensor, the suspension is changed to MEDIUM for improved riding

comfort and bad road driving even if the damping force should be set to HARD by some other control.

Warning Display Function

When a breakdown is detected, the TOUR and SPORT ECS indicator light in the meter blinks at 0.5 sec.

intervals to warn the driver of an abnormality.

Fail-safe and Diagnosis Function

When the ECS control unit detects a breakdown, control related with that breakdown phenomenon stops and the

damping force is fixed on the fail safe side. At the same time, the self-diagnosis code related to the breakdown phenomenon is output to the diagnosis connector.

FAIL-SAFE AND DIAGNOSIS CODE TABLE

Diagnosis code No.	Diagnosis item	Fail-safe function						Damping force condition of shock absorber
		Anti-rolling control	Anti-diving control	Anti-squatting control	High speed response control	Pitching/bouncing control	Bad road detection control	
-	Normal	X	X	X	X	X	X	_____
11	G-sensor abnormal*	X	X	X	X	—	—	_____
21	Steering wheel angular velocity sensor, broken wire*	—	X	X	X	X	X	_____
24	Vehicle speed sensor, broke wire*	—	—	—	—	—	—	Shock absorber is fixed at MEDIUM
61	F.R. damping force changeover actuator, abnormal	—	—	—	—	—	—	Normal shock absorber is fixed HARD
62	F.L. damping force changeover actuator, abnormal	—	—	—	—	—	—	
63	R.R. damping force changeover actuator abnormal	—	—	—	—	—	—	
64	F.L. damping force changeover actuator, abnormal	—	—	—	—	—	—	

NOTE

1. An "X" indicates normal operation and a "---" indicates stop of control.
2. Control stop, warning display and fixing of damping force return to normal operation when the ignition switch is turned OFF. However, in the case of breakdowns marked with an asterisk (*), normal operation is resumed if normal output is generated even when the ignition switch is in ON (e.g. transient breakdown). In this case, the self-diagnosis code is in memory in the ECS control unit even while normal operation resumes.

3-20 DRIVE-CONTROL COMPONENTS - Electronic Control Suspension (ECS)

Service data output function

The ECS control unit receives the data input for control and outputs it to the diagnosis connector as a serial signal.

SERVICE DATA CHART

Item No.	Service data items
11	G-sensor output
14	Throttle position sensor output
21	Steering wheel angular velocity sensor output
24	Vehicle speed sensor output
26	Stop lamp switch
61	F.R. actuator condition
62	F.L. actuator condition
63	R.R. actuator condition
64	R.L. actuator condition

Actuator test function

By using the multi-use tester to send an order to the ECS control unit, it is possible to force-drive the actuator.

ACTUATOR TEST CHART

Item No.	Actuator test items	Shock absorber damping condition
01	Damping force SOFT	Damping force for 4 shock absorbers set to SOFT
03	Damping force MEDIUM	Damping force for 4 shock absorbers set to MEDIUM
04	Damping force HARD	Damping force for 4 shock absorbers set to HARD

NOTE

The damping force set is released under the following 3 conditions

- Ignition switch is turned OFF
- Vehicle speed becomes 3km/h (1.9 mph) or more
- Multi-use tester is disconnected

WHEEL AND TYRE**SPECIFICATIONS**

Items	Specifications
Tyre size	225/50R17
Wheel type	Aluminum type
Wheel size	17 x 7 1/2 JJ
Amount of wheel offset	46 (1.8)
Tyre inflation pressure	mm (in.)
Front	kPa (kg/cm ² , psi)
Rear	220 (2.2, 32)
	200 (2.0, 29)

POWER STEERING

- The steering wheel comes with SRS (Supplemental Restraint System). (Refer to GROUP 6-SRS for SRS.)
- The steering column has a shock absorbing structure and tilt steering mechanism.
- The oil pump is a vane type oil pump with a fluid flow control system so the steering force varies according to engine speed.
- The steering gear and linkage uses an integral type rack and pinion system.

SPECIFICATIONS

Items	Specifications
Steering wheel maximum turns	2.52
Steering angle (vehicle in unladen)	
Inner wheel	33°45' ± 2°
Outer wheel	28°21'
Steering gear and linkage	
Type	Integral type
Gear type	Rack and pinion
Gear ratio	(infinity)
Rack stroke	144 (5.7) mm (in.)
Oil pump type	Vane type with fluid flow control system
Displacement	cm ³ /rev. (cu.in. / rev.) 9.6 (0.59)
Relief set pressure	MPa (kg / cm ² , psi) 8 (80, 1,138)

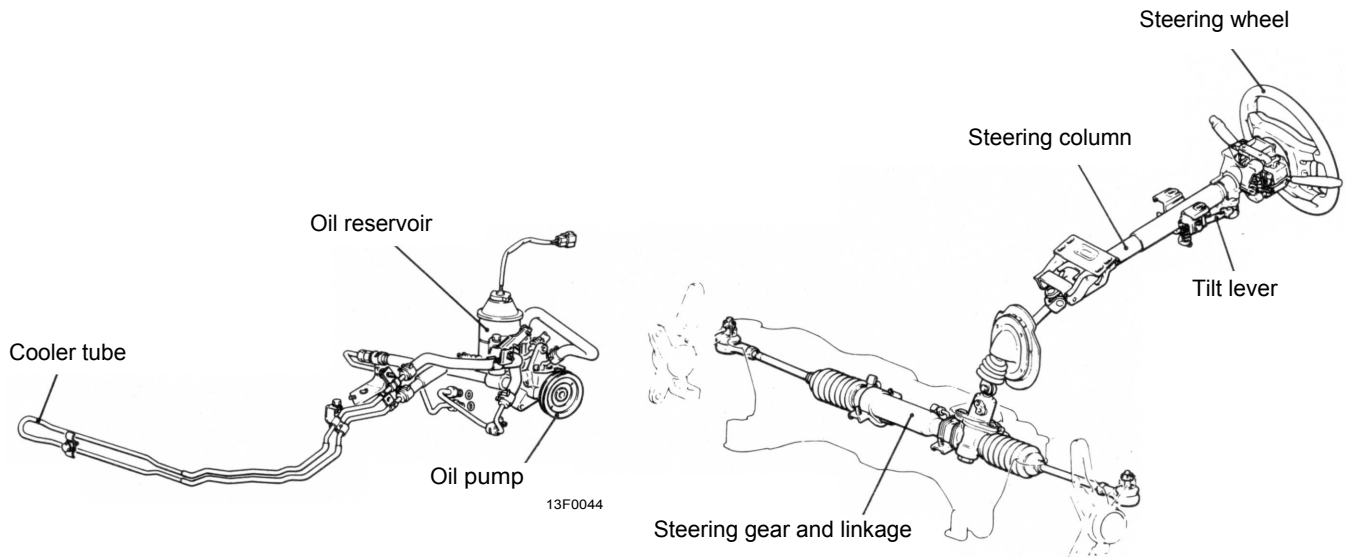

STEERING WHEEL AND COLUMN

The steering wheel and column have the following features that make maneuverability and safety really outstanding.

- The steering wheel has an outstanding design that promotes maneuverability and a good view of the meters.
Furthermore, SRS is built into the steering wheel to assure driver protection.
- The steering shaft and column absorb shock energy when there is a collision with its shock absorbing structure that protects the driver.
- The height of the steering wheel can be adjusted. A tilt steering mechanism is used to obtain the best driving position and the ideal driving posture.

STEERING WHEEL CONSTRUCTION

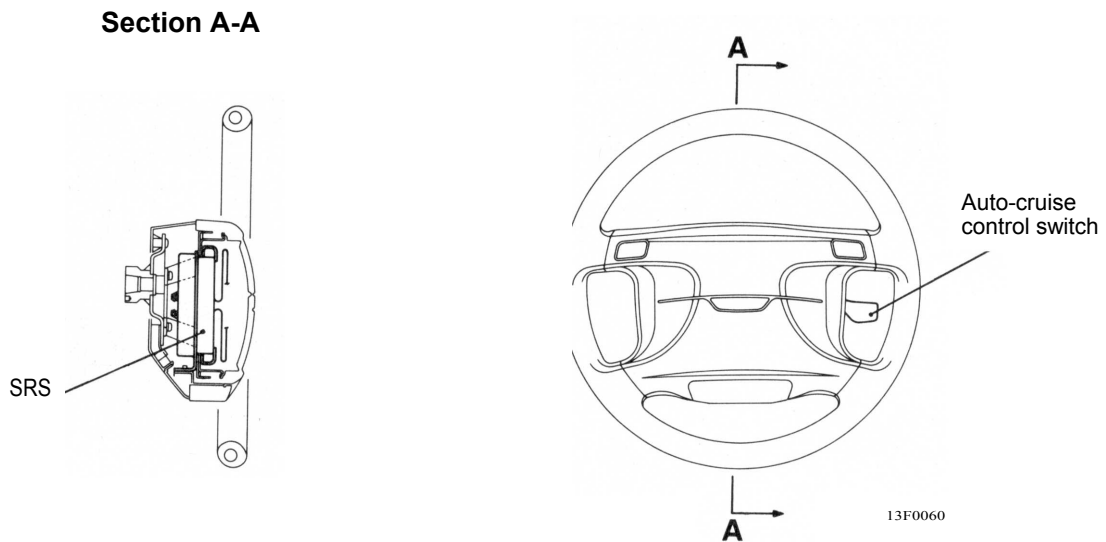

TILT STEERING CONSTRUCTION

The tilt steering consists of the tilt lever, tilt bolts (A, B), tilt bracket and column plate, etc. The tilt bolts (A, B) are attached to the end of the tilt lever; tilt bolt A

has right threads and tilt bolt B has left threads, and the tilt bracket is pressed and fixed to the column plate with the tilt bolts (A, B).

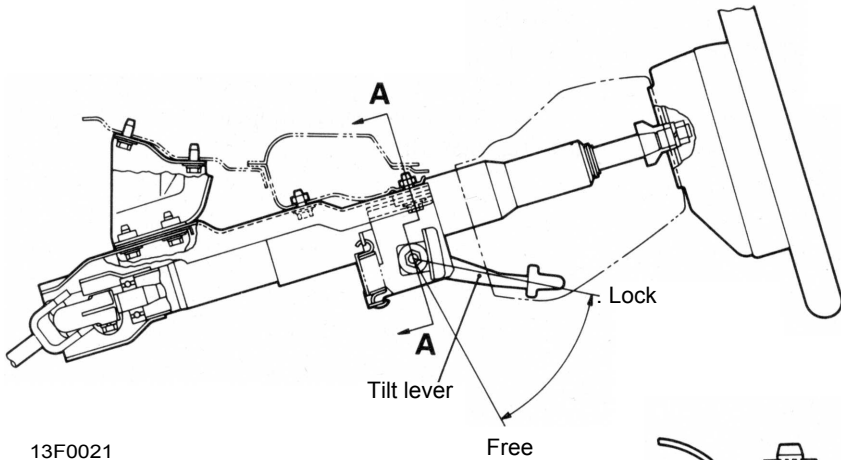

13F0021

Cross section A-A

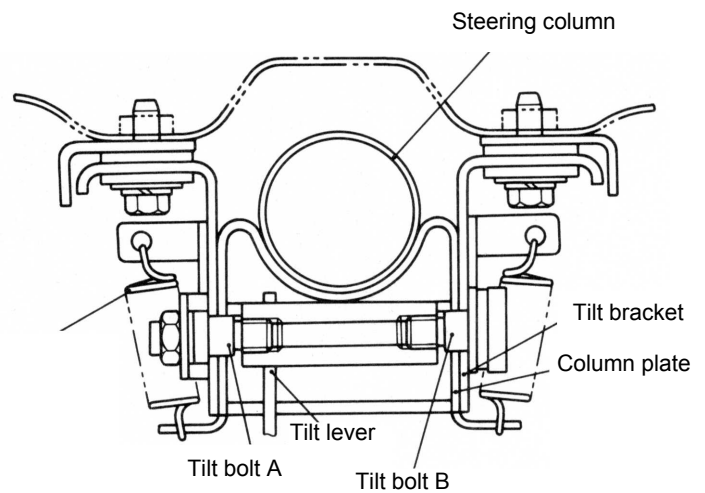

13F0016

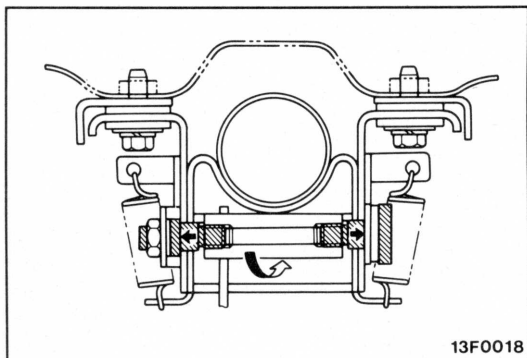

13F0018

TILT STEERING OPERATION

(1) If the tilt lever is lowered to the free position, the tilt bolts (A, B) move in the loosening direction (outer side) so the steering column can be slid up and down.

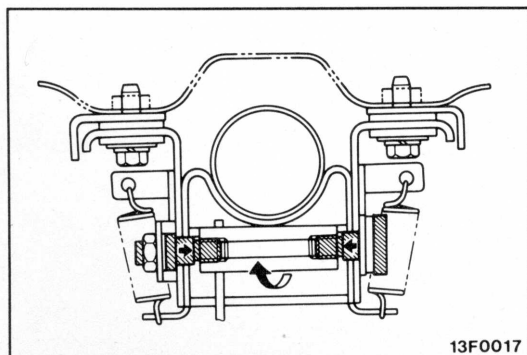

13F0017

(2) If the tilt lever is pulled up to the lock position, the tilt bolts (A, B) move in the tightening direction (inner side) so the tilt bracket is pressed to the column plate, fixing the steering column.

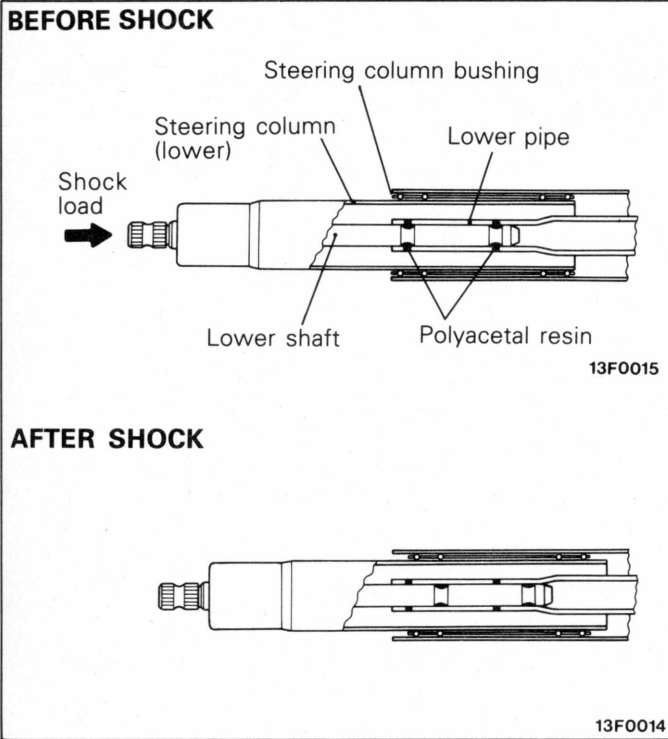

SHOCK ABSORBING STRUCTURE

(1) When the vehicle collides with something and there is a load added to the steering shaft from the gear box (primary shock), the lower shaft of the steering shaft assembly crushes the polyacetal resin, absorbing the shock load using the friction of the steering column (lower) and steering column bush as it slides into the lower pipe.

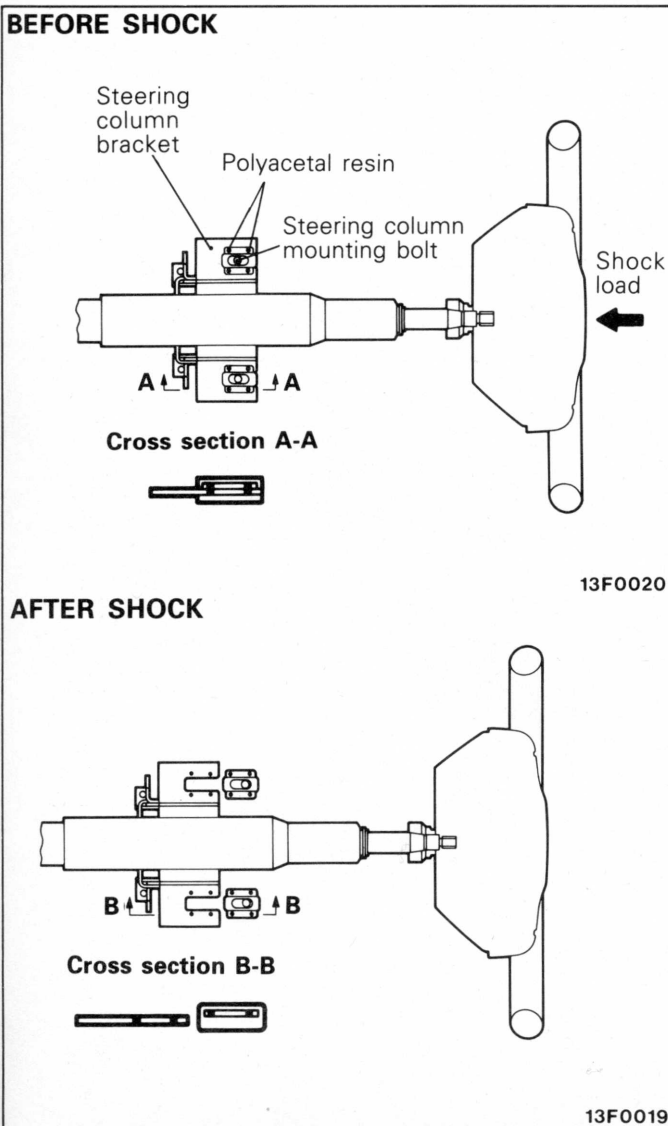

(2) When the driver strikes his body on the steering wheel (secondary shock), the steering column bracket crushes the polyacetal resin, pushing it to the front and absorbing the shock load.

OIL PUMP

The oil pump is a vane type oil pump with fluid flow control system that provides light steering at low

engine speed and ideal harder steering at high speed.

OIL PUMP PERFORMANCE

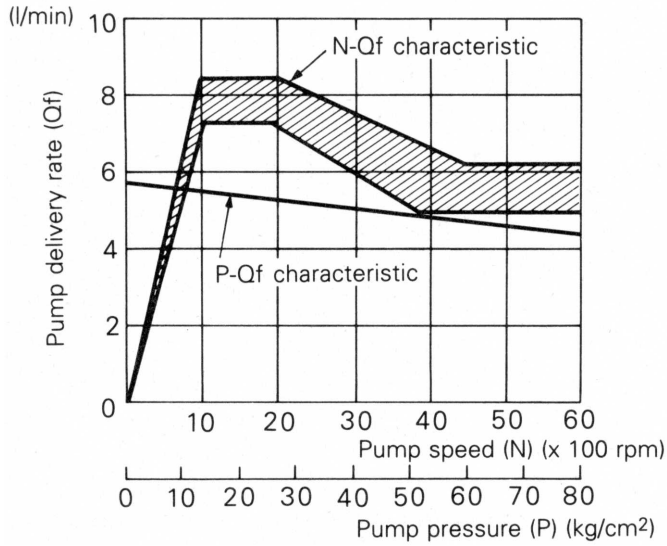

13F0042

NOTE

- (1) P-Qf characteristic: Pump pressure and pump delivery rate
- (2) N-Qf characteristic: Pump speed and pump delivery rate

4 WHEEL STEERING (4WS) SYSTEM

By adding steering to the rear wheels, a 4 wheel steering system has been established which improves controllability and stability in the medium and high speed range.

NOTE

The 4WS vehicles are basically identical to Galant 4WD in the construction and operation of the 4WS.

SPECIFICATIONS

Items	Specifications
Rear wheel max. steering angle (deg)	1.5
Steering gear & linkage Type Gear type Gear ratio Rack stroke	Integral type Rack & pinion type Infinite 144 ± 1 (5.67 ± 0.04) mm (in.)
Power steering oil pump Type Delivery rate Relief set pressure Rotating direction	Vane type (with flow control valve) 9.6 (0.59) cm ³ / rev. (cu.in. / rev.) 8 (80, 1,138) MPa (kg / cm ² , psi) Clockwise (viewed from pulley side)
Rear wheel steering oil pump Type Delivery rate Relief set pressure Rotating direction (normal)	Vane type (with flow control valve) 3.3 (0.20) cm ³ / rev. (cu.in. / rev.) 4 (40, 569) M Pa (kg / cm ² , psi) Clockwise (viewed from gear side)
Power cylinder Type Full stroke Cylinder bore	Hydraulic double-acting type 20 (0.8) [10 (0.4) for one side] mm (in.) 43 (1.7) mm (in.)

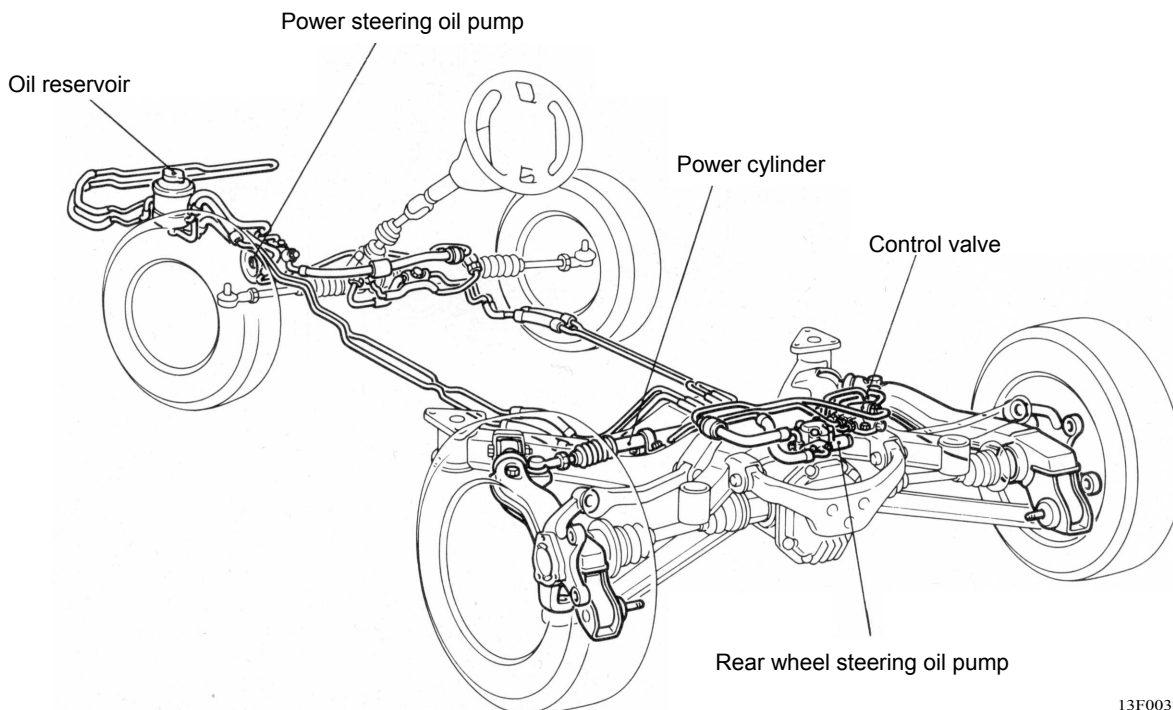

3-28 DRIVE-CONTROL COMPONENTS - 4 Wheel Steering (4WS) System

SYSTEM CONSTRUCTION

- The hydraulic power cylinder is connected to the middle joint of the rear trailing arms.
- Hydraulic pressure for the rear steering power cylinder is generated by an oil pump driven by the rear differential gear. This pressure is controlled by the power steering hydraulic pressure via the control valve. In this way, the rear wheel steering angle is controlled according to the front wheel steering effort.
- The oil pump for the rear wheel steering delivers the amount of oil proportional to the rear wheel speed. This allows rear wheel steering angle control proportional to the vehicle speed at middle and high speeds [over approx. 50 km/h (31 mph)].
- This construction allows the rear wheels to be steered in the same phase with the front wheels when cornering at middle and high speeds, developing side force at the rear tyres almost simultaneously with side force generation at the front tyres.

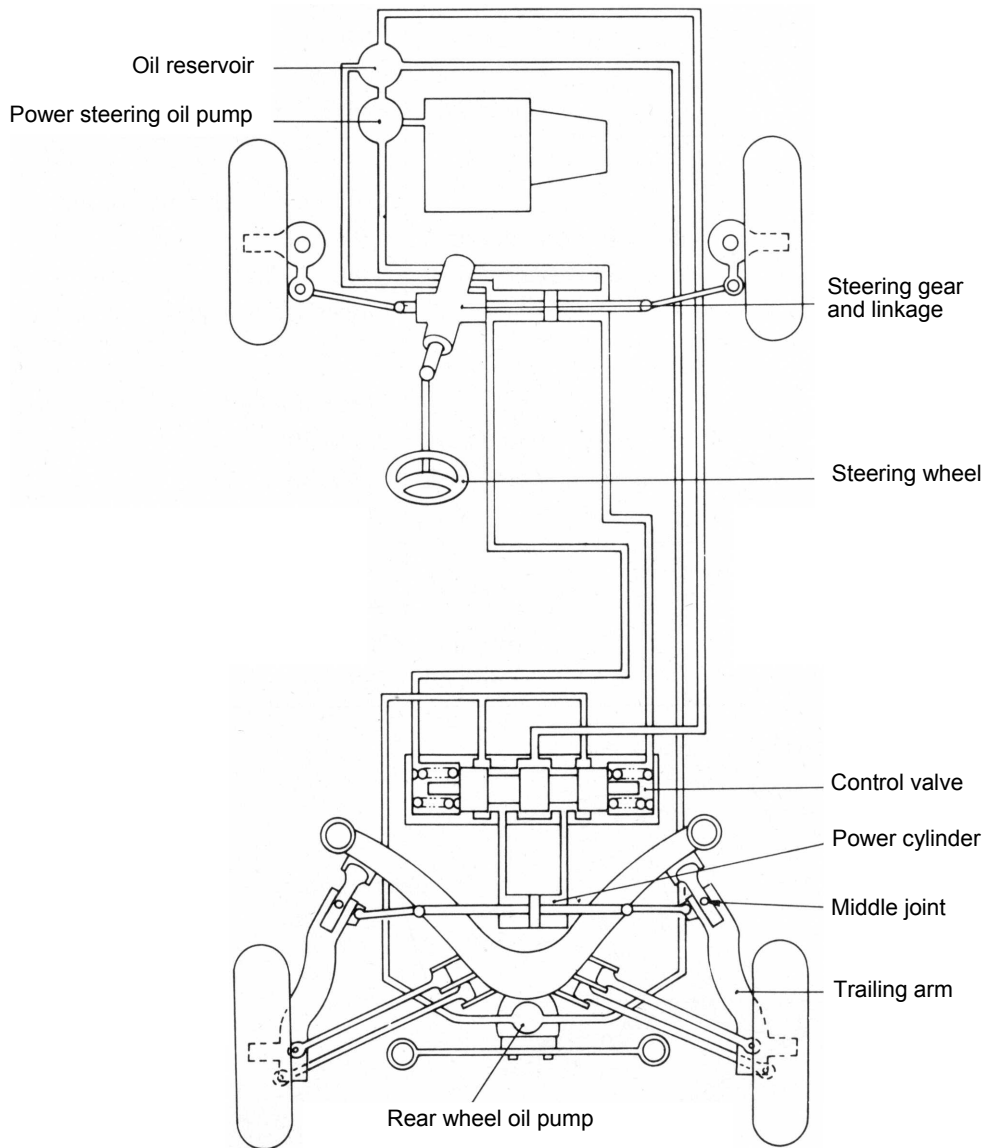

REAR WHEEL STEERING OIL PUMP

The rear wheel steering oil pump driven by a dedicated drive gear in the rear differential carrier delivers the amount of oil corresponding to the rear wheel speed.

The basic construction of the pump is the same as the power steering oil pump.

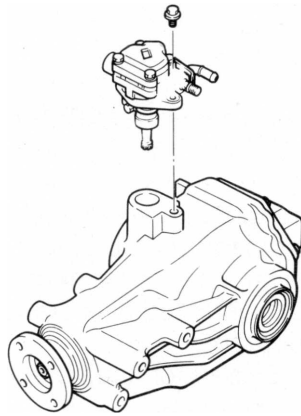

13F0010

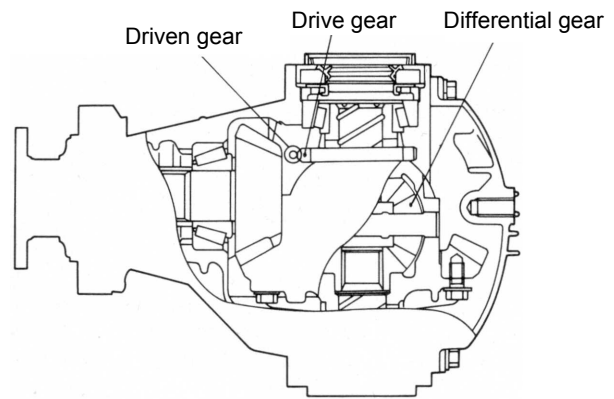

13F0006

CONTROL VALVE

Mounted on the top of the rear suspension cross-member, this control valve controls oil pressure to the power cylinder by controlling the spool that switches the

oil flow path by pilot oil pressure from the steering gear box.

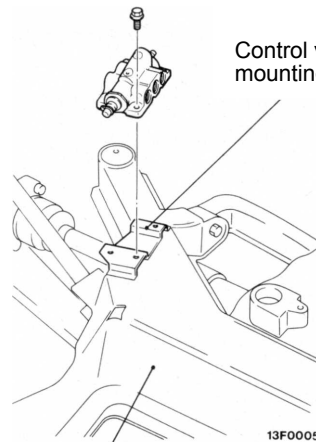

13F0005

POWER CYLINDER

The power cylinder tie rod is linked to the middle joint of the right and left trailing arms. The piston rod in the power cylinder moves either to the right or left ac-

ording to the steering wheel effort and vehicle speed, thereby steers the rear wheels.

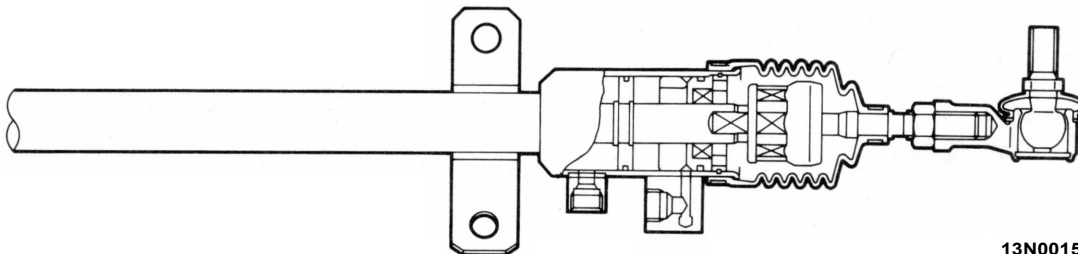

13N0015

BRAKES

The service brakes use a brake system featuring excellent braking force and a high level of reliability and durability.

FEATURES

Improved braking performance

1. Four-wheel anti-lock braking system (4ABS) to prevent slipping due to locking of the wheels and for applying the ideal braking force is used.
2. Ventilated brake discs are used on all four wheels.
3. Face-to-face and different diameter 4-piston front ventilated disc brakes made from aluminium have been adopted.
4. Face-to-face 2-piston rear ventilated disc brakes made from aluminium have been adopted.
5. A tandem brake booster is used for a big braking force with a light pressure on the brake pedal.

Improved serviceability

1. A diagnosis function has been adopted in the ABS.

Improved safety

1. An audible wear indicator is adopted to warn the limit of pad use.
2. The X-arrangement of the brake lines for front and rear wheels is used.

**SERVICE BRAKES
SPECIFICATIONS**

Items	Vehicles for Europe		Vehicles for General Export, GCC and Australia	
Master cylinder Type 1.0.	mm (in.)	Tandem (with level sensor) 26.9 (1 1/16))	Tandem (with level sensor) 26.9 (1 1/16)	
Brake booster Type Effective dia. of power cylinder	mm (in.)	Vacuum type, tandem 205 (8.0) + 230 (9.0)	Vacuum type, tandem 205 (8.0) + 230 (9.0)	
Proportioning valve Type Split point Decompression ratio	kPa (kg/cm ² , psi)	Dual type 3,750 - 4,250 (37.5 - 42.5, 533 - 604) 0.37	Dual type 2,750 - 3,250 (27.5 - 32.5, 391 - 462) 0.25	
Front brakes Type Disc effective dia. x thickness Cylinder I.D. Clearance adjustment	mm (in.)	Rigid caliper, 4-piston, ventilated disc (M-R76Z) 270 x 30 (10.6 x 1.18) 40.4 (1 19/32) x 2 + 42.8 (1 11/16) x 2 Automatic	Rigid caliper, 4-piston, ventilated disc (M-R66Z) 249 x 30 (9.8 x 1.18) 40.4 (1 19/32) x 2 + 42.8 (1 11/16) x 2 Automatic	
Rear brakes Type Disc effective dia. x thickness Cylinder I.D.	mm (in.)	Rigid caliper, 2-piston, ventilated disc (M-R68X) 250 x 20 (9.8 x 0.79) 38.1 (1 1/2) x 2	Floating caliper, 1-piston, ventilated disc (M-R58V) 237 x 20 (9.4 x 0.79) 38.1 (1 1/2)	
Rotor teeth Front Rear		47 47	47 47	
Speed sensor		Magnet coil type	Magnet coil type	

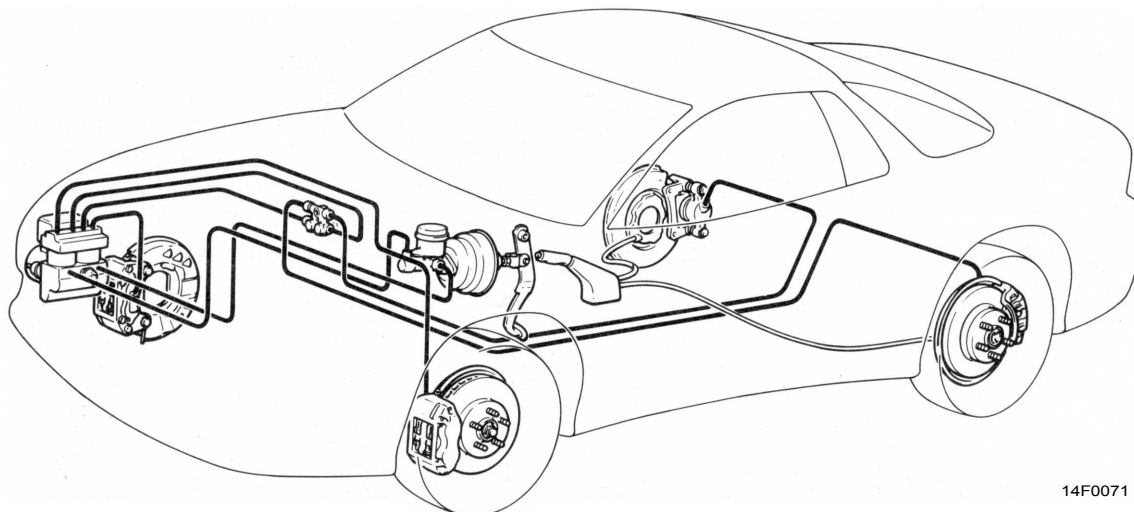

FRONT DISC BRAKE

A face-to-face and different diameter 4-piston type made from aluminium has been adopted for the front disc brakes.

Not only is braking force well balanced with pressure applied evenly over the entire pad surface but there is also outstanding and stable braking performance preventing uneven pad wear and providing a good

braking feeling.

For safety, there is an audible wear indicator on the inner side of the pad to warn when the limit of pad use has been reached.

Clearance is automatically adjusted by pressing on the brake pedal.

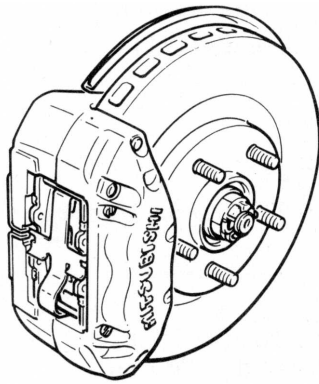

14F0029

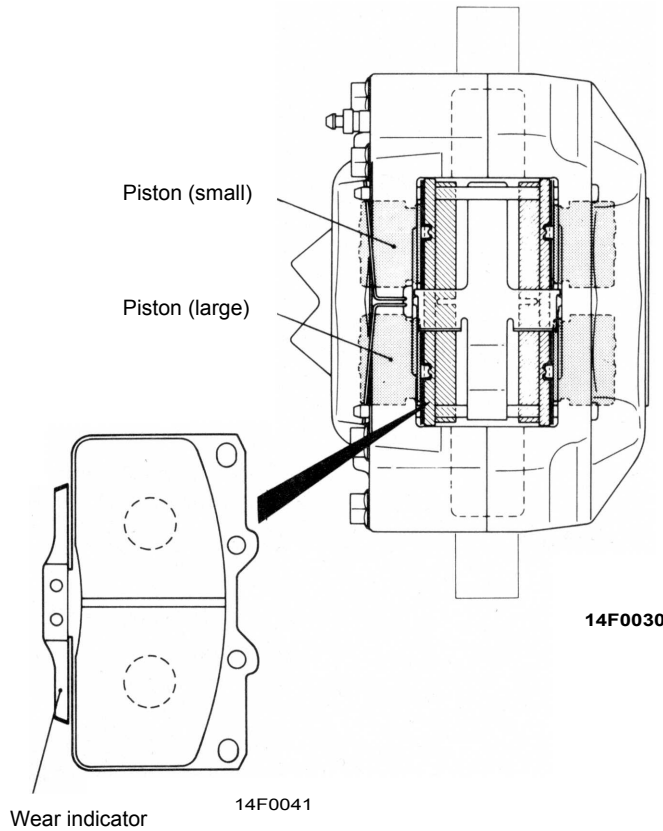

14F0030

14F0041

Wear indicator

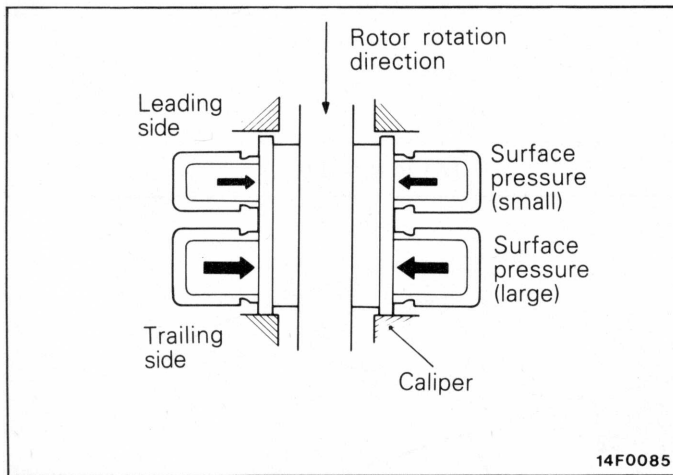

14F0085

DIFFERENT DIAMETER PISTONS

During braking, hydraulic pressure is generated in each piston to press the pad against the rotor. Since there is a lengthwise play between the pad and the caliper, the pad is pressed against the trailing side caliper and a gap is made on the leading side.

At this time, not only the piston surface pressure but also the moment act on the leading side pad and wear on the leading side pad is increased. Therefore, since the leading side piston diameter is made small and the surface pressure distribution is smaller than on the trailing side, the pad acting force both on leading side and trailing side is balanced for equal wear.

REAR DISC BRAKE

A face-to-face 2-piston type made from aluminium has been adopted for the rear disc brakes in vehicles for Europe, and floating caliper single piston type has been adopted in vehicles for General Export, GCC and Australia.

In addition, a drum in disc method is used with a parking

brake built into the brake disc.

For safety, there is an audible wear indicator in the inner side of the pad to warn when the limit of pad use has been reached.

Clearance is automatically adjusted by pressing on the brake pedal.

<Vehicles for Europe>

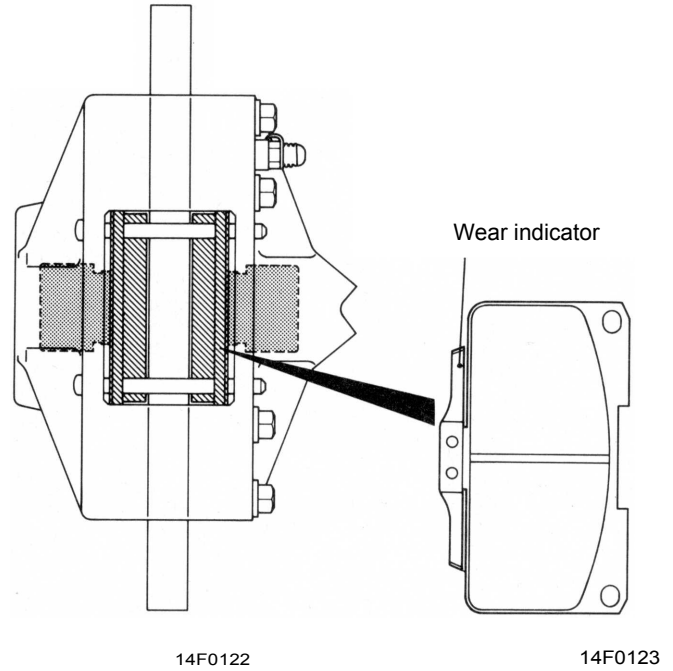
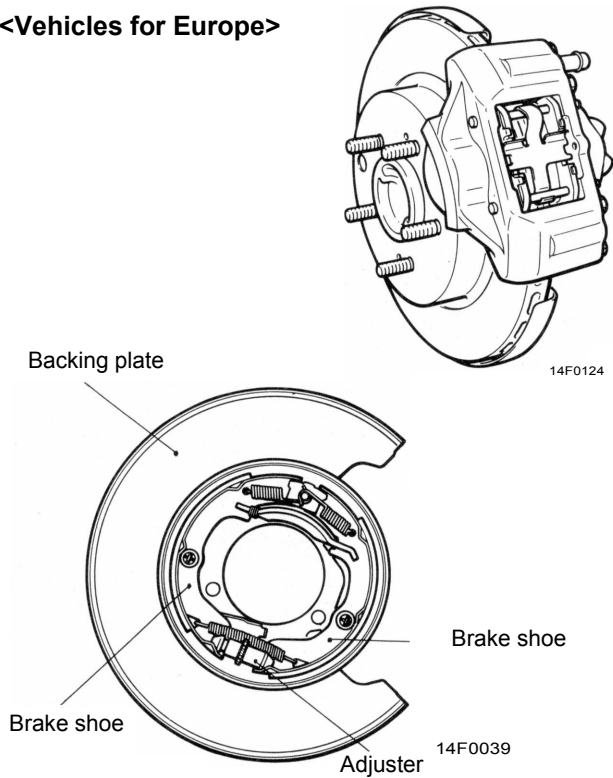

<Vehicles for General Export, GCC and Australia>

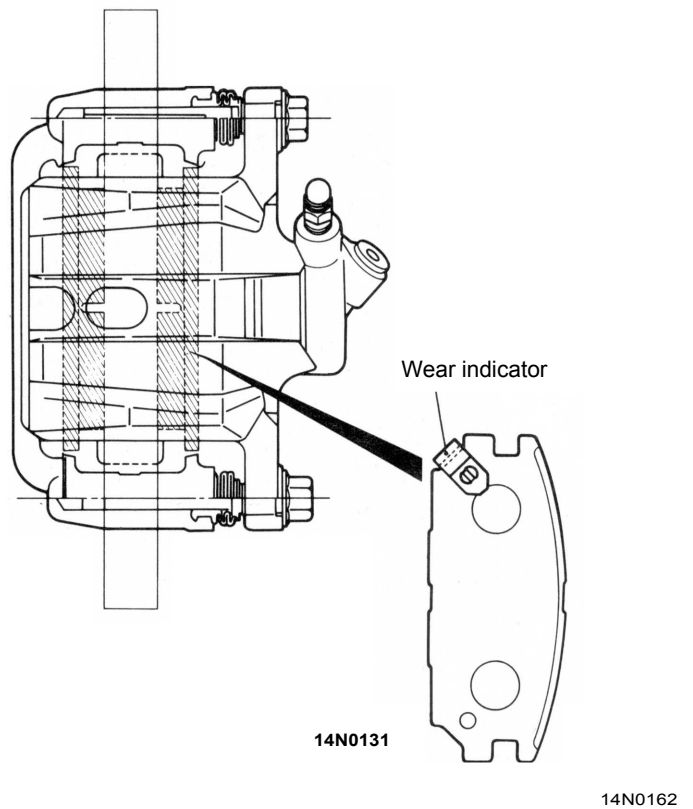
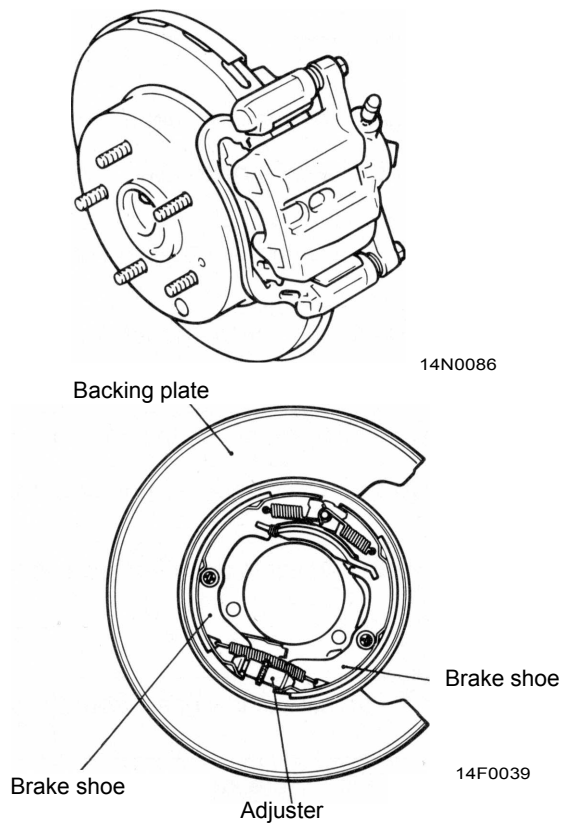

ANTI-LOCK BRAKING SYSTEM (ABS)

With the use of ABS in 4WD models, not only is the "driving" of a 4WD model improved but the "stopping" performance is also greatly improved. Driving performance is well balanced in all ways from better

performance on dry roads to better performance under all conditions such as slippery road surfaces, etc. The ABS is a 4 sensor, 2 channel system, and is basically the same as that equipped in the GALANT 4WD.

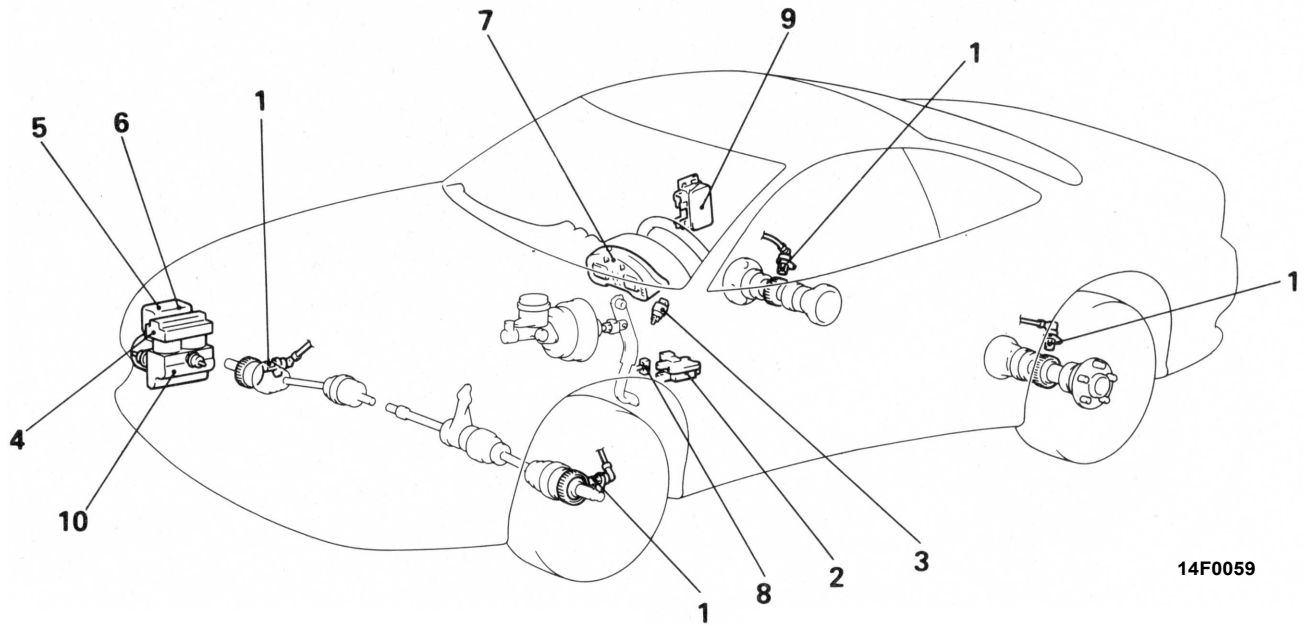

14F0059

Part name		No.	Function
Sensor	Wheel speed sensor	1	Sends a wheel speed signal from each wheel to the ECU.
	G-sensor	2	Sends an ON/OFF signal to the ECU depending on vehicle acceleration.
	Stop lamp switch	3	Sends a signal to the ECU indicating whether the brake pedal is pressed on not.
Actuator	Hydraulic unit (HU)	4	Controls braking pressure for each wheel depending on the signal from the ECU. Includes built-in select-low valve
	Motor reltly	5	Is turned ON by the ECU signal and drives the pump motor in HU.
	Valve relay	6	Is turned ON by the ECU signal and supplies power to the solenoid valve in HU.
	ABS warning lamp	7	Is in the combination meter and lights up when there is trouble iO ABS.
	Diagnosis connector	8	Outputs diagnosis codes.
Electronic control unit (ECU)		9	Drives the hydraulic unit, etc. based on signals from the various sensors.
Select-low valve		10	Is in HU and matches brake pressure in the rear right and left wheels to the pressure on the low side.

SYSTEM DRAWING

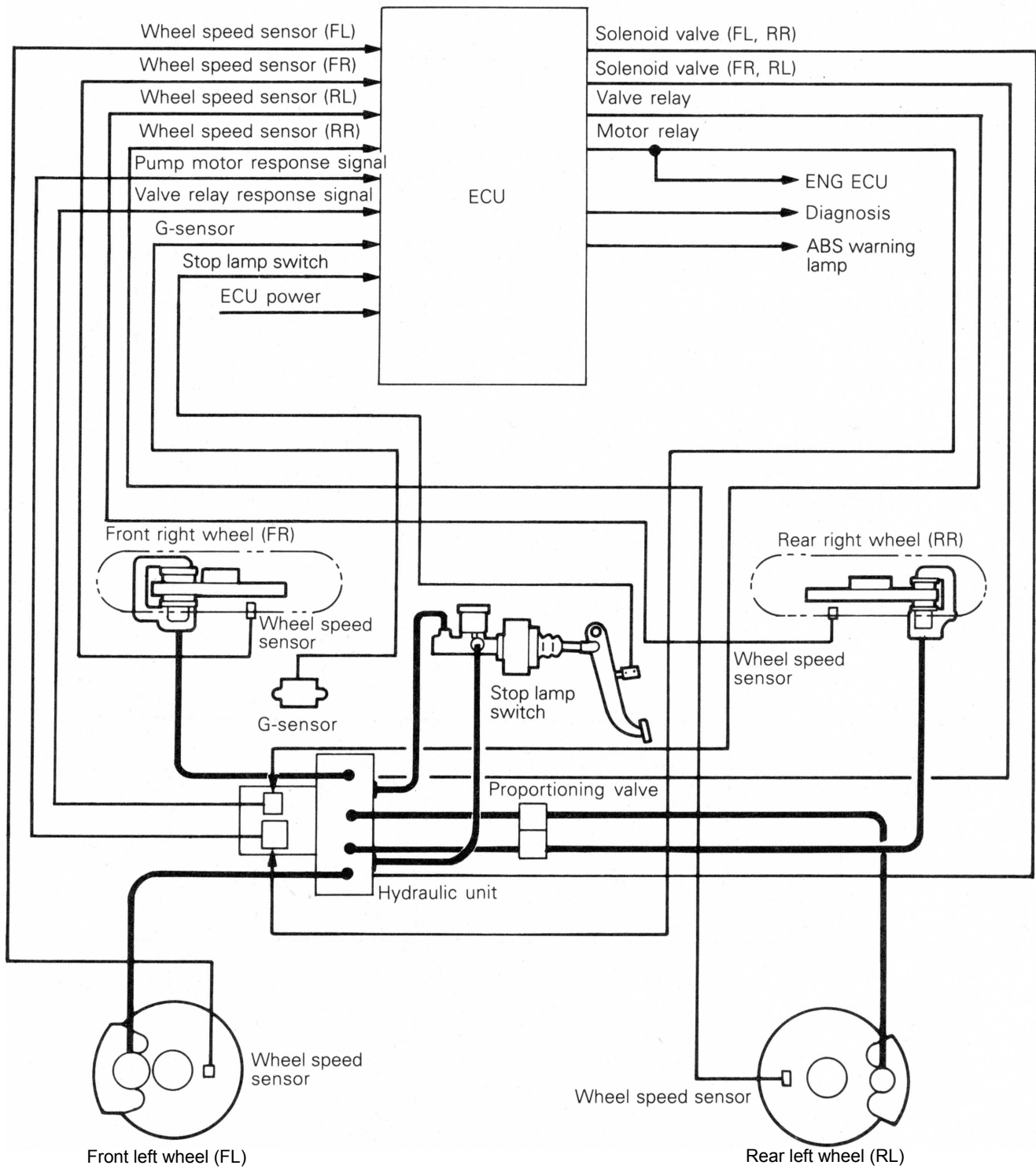

3-36 DRIVE-CONTROL COMPONENTS - Anti-lock Braking System (ABS)

ABS ELECTRIC DIAGRAM

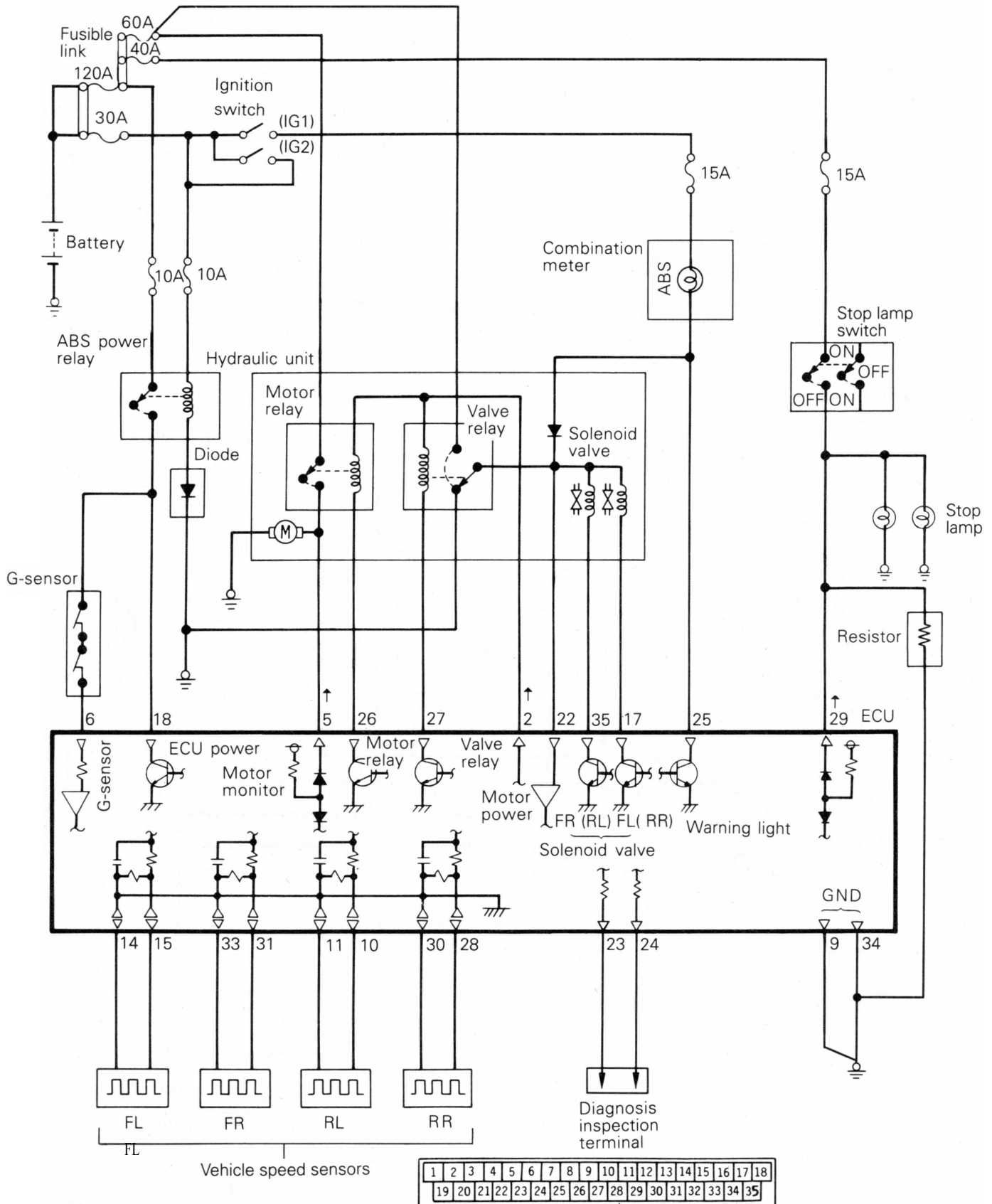

ABS HYDRAULIC FUNCTION DRAWING

The ABS uses 2 channels (2 hydraulic systems) with the hydraulic control method being as follows. It controls the front and rear wheels on the same side with select-low and drives the solenoid valve including the one for the front wheel. For example, when either the front or rear wheel on the right side is about to lock, it maintains or loosely controls the solenoid valve including the one for the front right wheel. And in order to prevent locking of one rear wheel, there is a select-low valve and the rear right and left wheels are controlled mechanically by select-low. Consequently, a total of three wheels - the front right or left wheel and the

rear right and left wheels - are controlled hydraulically at the same time. Also, if vehicle speed exceeds approximately 8 km/h (5.0 mph), the brake hydraulic pressure control is applied and when it becomes less than approximately 3 km/h (2.0 mph), the control is completed. Select-low: this is a method of providing the same hydraulic control to both wheels when either wheel is about to lock, matching it to the side about to lock, or a method to control by matching pressure to the low side.

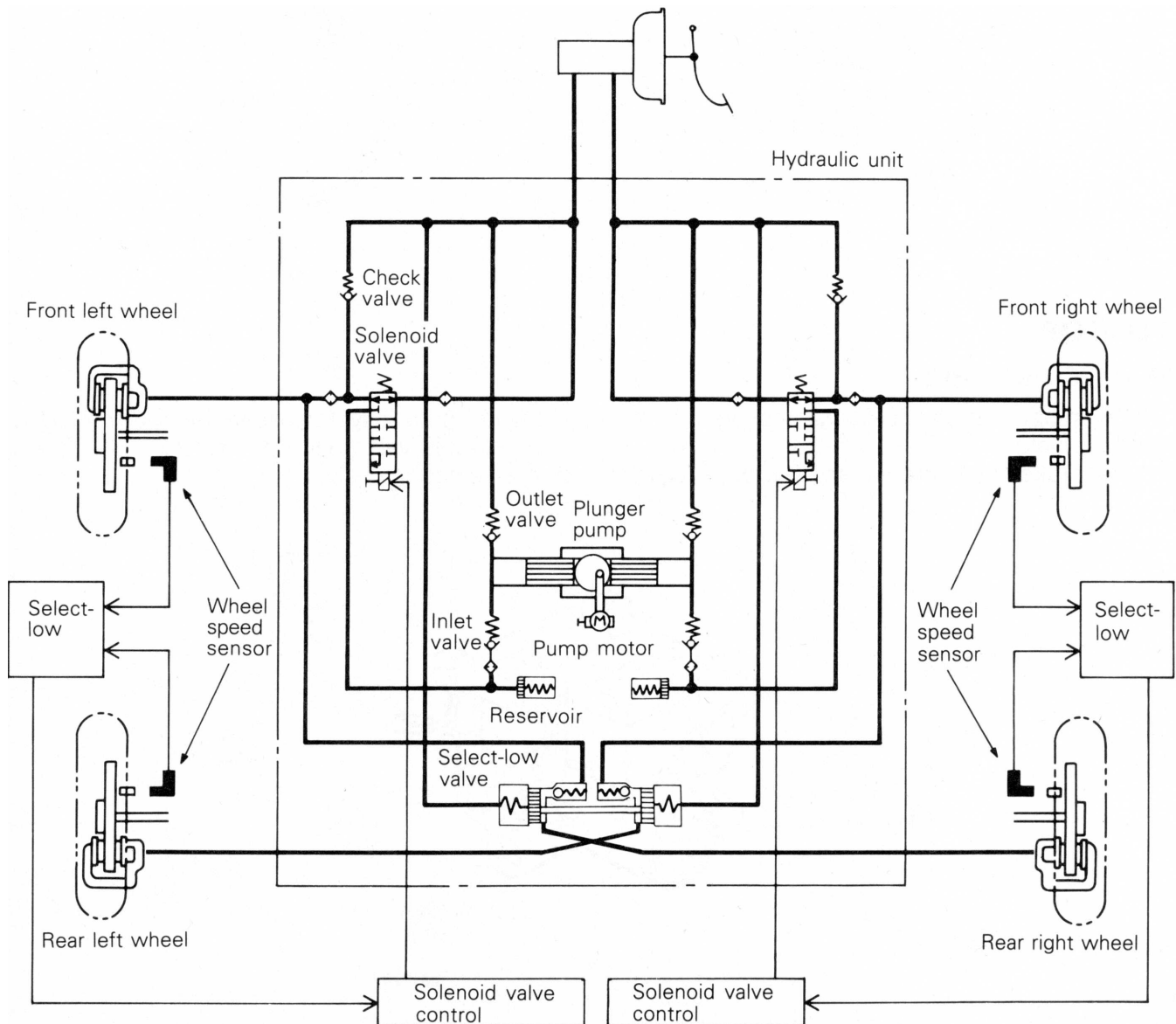

3-38 DRIVE-CONTROL COMPONENTS - Anti-lock Braking System (ABS)

SENSOR

WHEEL SPEED SENSOR

- The sensors for the front wheel consist of a speed sensor mounted on the knuckle and a rotor (47 teeth) that is mounted on the drive shaft (B.J. outer race).
- The sensors for the rear wheel consist of a speed sensor mounted on the trailing arm axle housing and a rotor (47 teeth) that is mounted on the rear axle shaft.
- By improving the mounting precision of the sensor, it is possible to make the speed sensor and rotor gap unadjustable types.

Front wheel

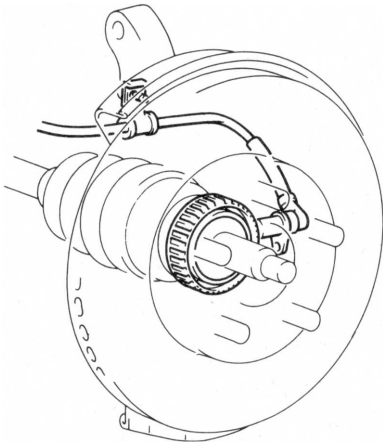

14F0057

Rear wheel

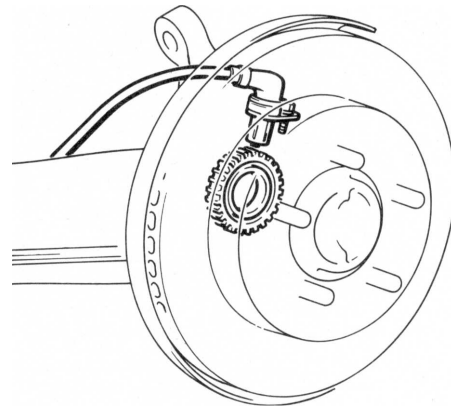

14N0118

ACTUATOR

HYDRAULIC UNIT (HU)

The HU is supported elastically via the bracket in the fender shield.

Since the brake lines are in an X-arrangement, there is

also a 2-system separation in the HU with one solenoid valve each (for total of 2). There is also a select-low valve.

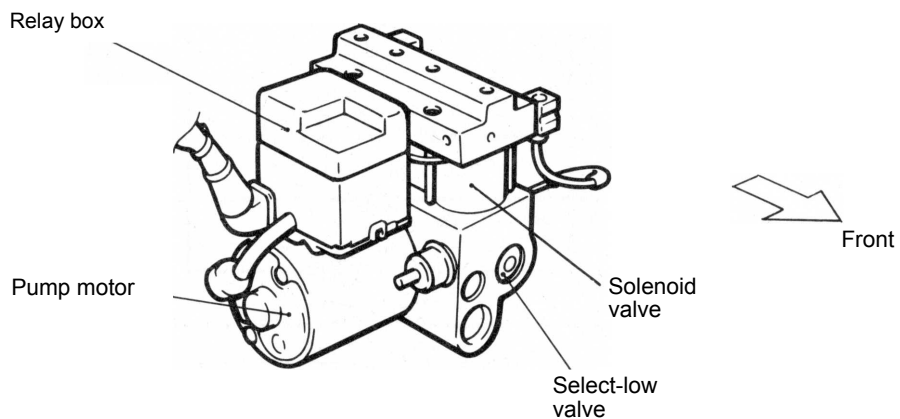

14F0072

ELECTRONIC CONTROL UNIT (ECU)

The ECU is mounted on the quarter inner lower panel (RH). The ECU is made up of 2 microprocessors, input/output interface, etc. Since there are two central processing units (CPU), there is a double check; the wheel speed sensor signal and valve control signal are

compared by both CPUs and, if the data do not match, ABS control is stopped. Furthermore, there is a diagnostic function for easy diagnosis of breakdowns.

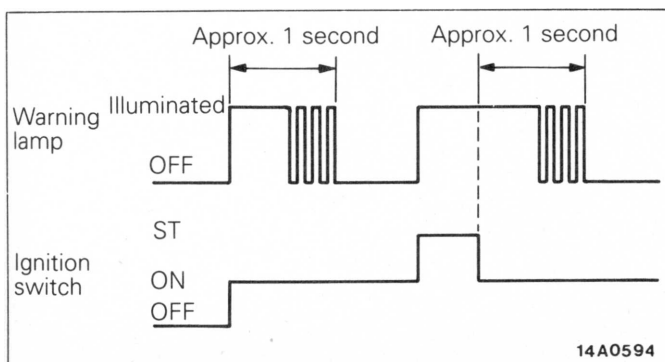
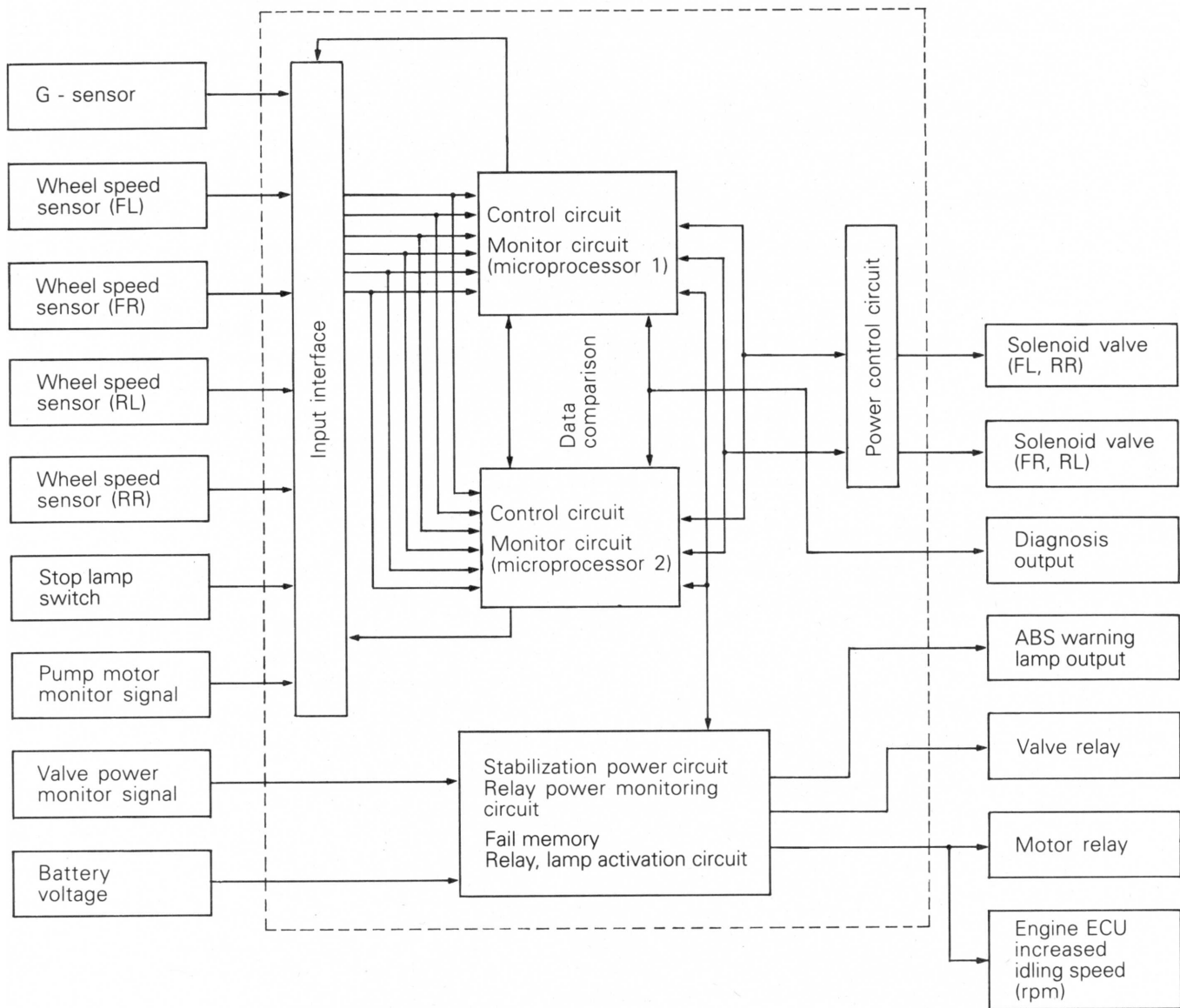

WARNING LAMP CONTROL

The lamp illuminates when an abnormality is detected in the system. Also, the lamp will illuminate as shown in the illustration at left in conjunction with operation of the ignition switch when checking a lamp blowout.

3-40

DRIVE-CONTROL COMPONENTS - Anti-lock Brake System

DIAGNOSIS FUNCTIONS

The ECU has the following functions to facilitate inspection of the system.

- Self-diagnosis code output function
- Actuator test function
- Diagnosis erasure function

SELF DIAGNOSIS CODE OUTPUT FUNCTION

There are 13 diagnosis items, and the diagnosis result is recorded even if the battery terminals are disconnected.

Output code	Diagnosis item	Output code	Diagnosis item
--	Normal	22	Stop lamp switch ON malfunction or broken wire
11	Broken wire or short in wheel speed sensor (FL.)	41	Abnormality in solenoid valve (FL., R.R.)
12	Broken wire or short in wheel speed sensor (F.R.)	42	Abnormality in solenoid valve (FR., R.L.)
13	Broken wire or short in wheel speed sensor (R.R.)	43	Solenoid valve drift error
14	Broken wire or short in wheel speed sensor (R.L.)	51	Abnormality in valve relay
15	Wheel speed sensor abnormality	52	Abnormality in motor relay or pump motor
21	Broken wire in G sensor or OFF malfunction	55	Abnormality in ECU

ACTUATOR TESTER FUNCTION

The actuator can be force-driven using the multi-use tester to enable easy operation inspection to be carried out.

NOTE

1. If the ECU function has been cancelled, then an actuator test cannot be carried out.

2. Actuator testing is only possible when the vehicle is stationary. If the vehicle speed during actuator testing exceeds 10 km/h (6 mph), forced actuation will be cancelled.
3. The following item numbers are the numbers input to the multi-use tester when an actuator test instruction has been given.

Item No.	Drive object	Drive pattern
04	Solenoid valve in each response channel in the hydraulic unit and pump motor (manual pattern)	<p>Increase in pressure Steady Decrease in pressure</p> <p>44 ms 3 s 3 s 8 ms</p> <p>ON OFF</p> <p>Start of forced actuation End of forced actuation</p> <p>14A0588</p>
05		

PARKING BRAKE

The parking brake is of the mechanical rear wheel braking type.

The parking brake is offset toward the driver's seat from the vehicle centreline for greater ease of operation.

The parking brake cable is of the V-type and is accessible for adjustment through the service hole provided in the floor console.

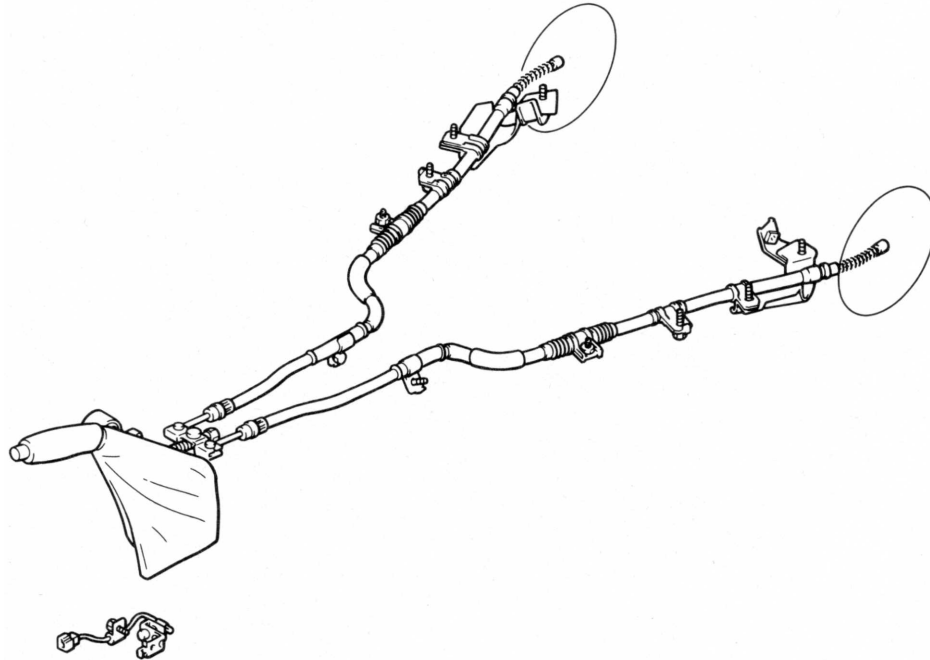

14F0064

NOTES

BODY

CONTENTS

GENERAL DESCRIPTION	2	DOORS	10
Features	2	Door Panel	10
MAIN BODY	3	Door Lock	11
Body Panelling	3	Window Glass Regulator	12
Body Shell	4	LID	13
Interference Panel Coating	6	Hood	13
3C1B Pearl Coating	7	Tailgate	13
Coloured Pearl Coating	7	WINDOW GLASS	13
Body Colour Charts	8	SUNROOF	14
AIR PRESSURE NOISE REDUCTION	9		
Flush Surface	9		
Full Glass Catch	10		

GENERAL DESCRIPTION**FEATURES**

Light weight
Added rigidity

1. Ample use of high strength steel sheets
2. Improvement in rigidity of outer door panels by use of effective reinforcements

Corrosion
control

1. Ample use of anti-corrosion steel sheets

Reduction in
vibrations,
noises and
aerodynamic
noise

1. Thorough utilization of flush surfaces
2. Adoption of full glass catches

Improved
controllability
and safety

1. Improvement in door operation feeling due to adoption of a roller type 2-step door check
2. Use of side door beams
3. Adoption of gas springs to reduce the operation force for opening and closing the hood

Improved
merchantability
and appearance

1. Rubber coating on door latches to improve the door operational feel and for less noise when opening and closing
2. Adoption of a detachable sunroof

**MAIN BODY
BODY PANELING**

High-tensile steel panels are used extensively and a structure that assures sufficient rigidity while maintaining the lightweight body is adopted.

Also, galvanized steel panels are used extensively in order to improve anti-rust performance.

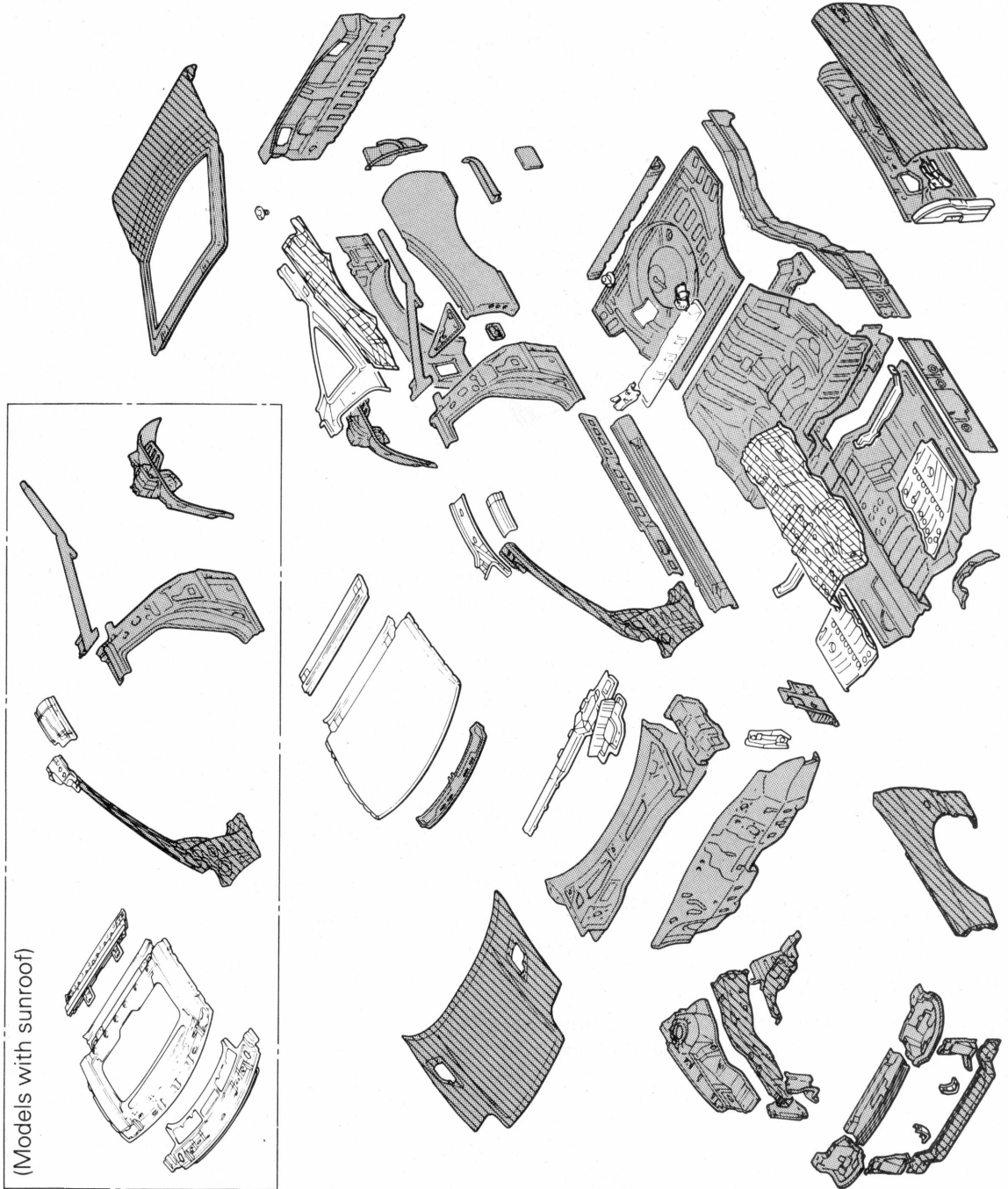
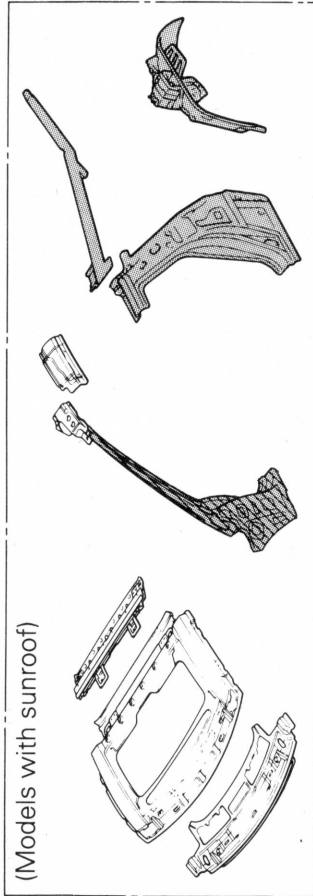

 : High-tensile steel panels
 : Galvanized steel panels

BODY SHELL

HEADLAMP SUPPORT

A structure as shown below is used with the large soft fascia which consists of the front bumper, skirt panel and header panel moulded into one unit.

(1) A large and very rigid front end upper bar is used.

Furthermore, the hood latch bracket has a closed cross section to improve strength.

(2) A large headlamp housing is used to improve strength.

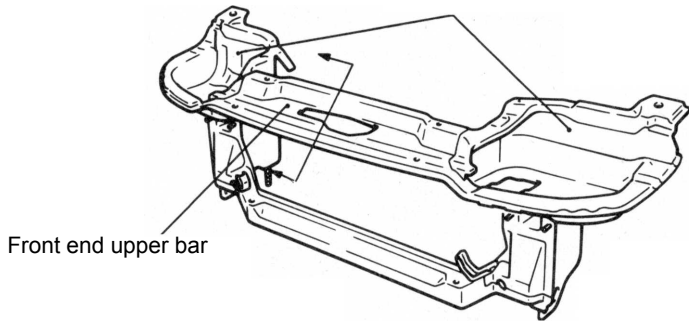

30F0064

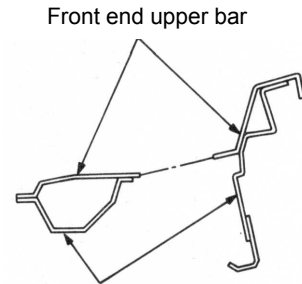

31 F0124

DASH PANEL

The dash panel is not a double-walled structure consisting of the dash panel and dash panel reinforcement as in former models but is made

from a single thick plate. The engine compartment has effectively expanded while preserving rigidity.

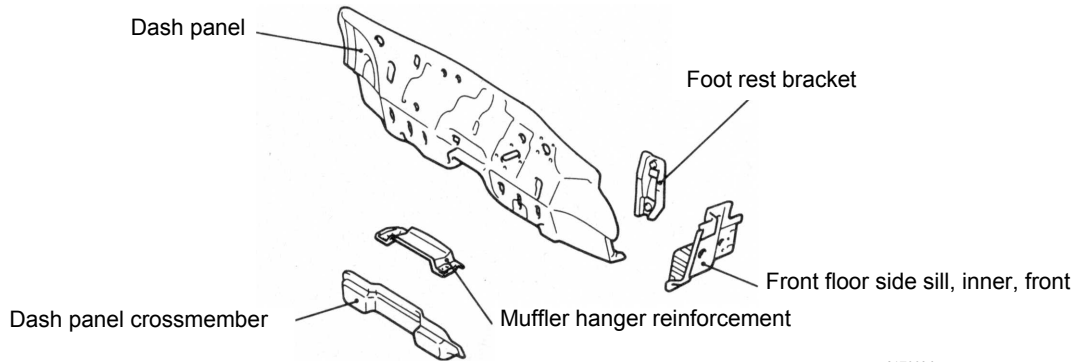

31F0096

REAR END PANEL

The rear end panel is mounted on the outside of rear lamp housings so the panel replacing work becomes easier.

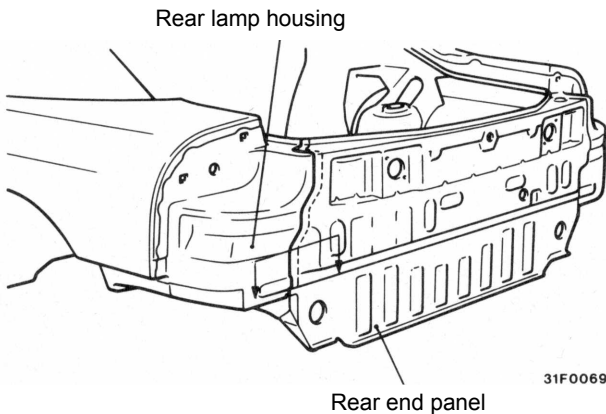

31F0069

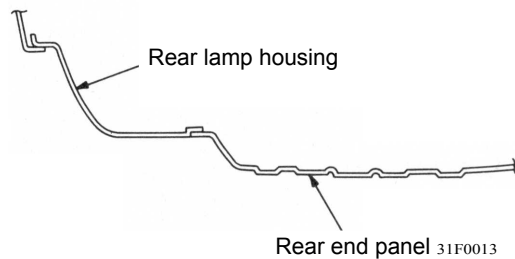

31F0013

FRONT FLOOR

A double-floor structure is adopted, this not only improves rigidity but also reduces air resistance because of the flatness of the floor's bottom surface.

(1) A very rigid, double-layer floor is used with a front floor sidemember on the upper surface of the front floor and also a front floor upper panel on top.

(2) There is large, integrated backbone reinforcement on the upper surface of the front floor to improve rigidity.

(3) The number of beads in the front floor pan is reduced to make the bottom surface of the floor flat.

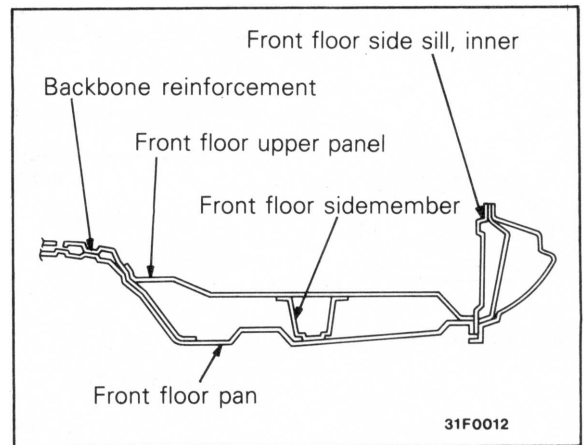
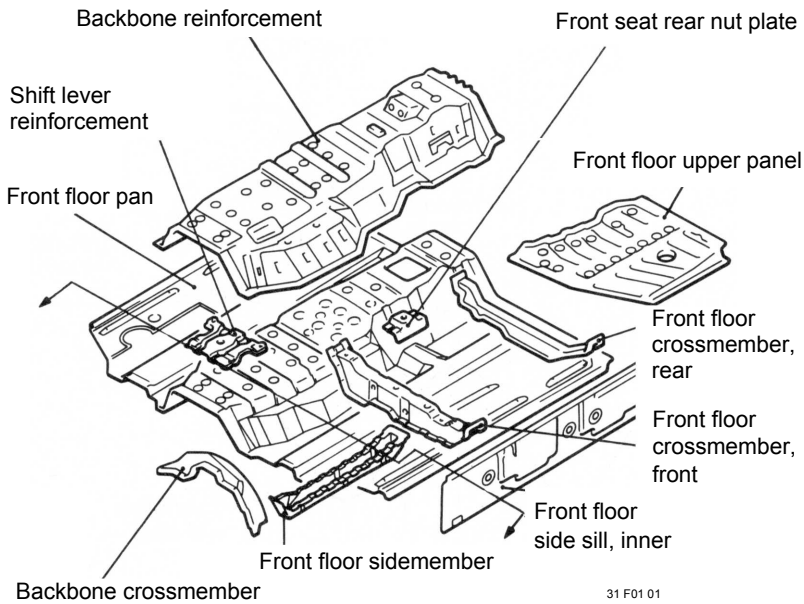

DOOR

A tubular type side impact bar has been adopted.

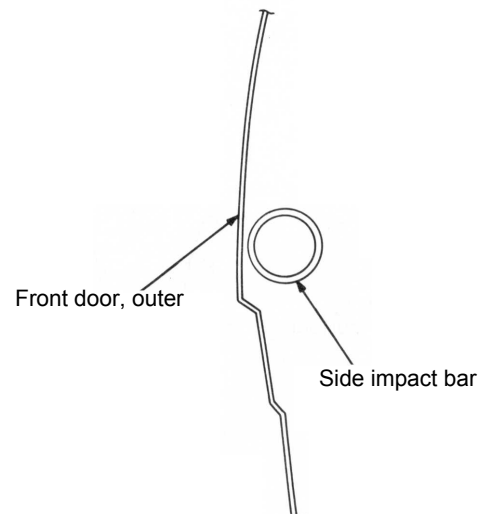
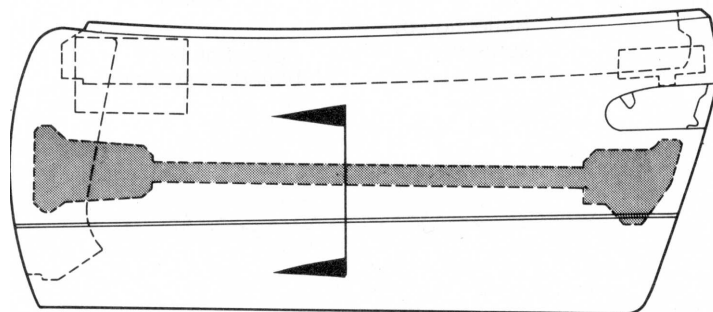

INTERFERENCE PEARL COATING

Powder mica used in interference pearl coating has its surface coated with titanium dioxide in the same way as the powder mica used in conventional white pearl coating. Since light is reflected by a boundary surface between objects of different density, the reflection of light occurs first on the titanium surface and then on the boundary surface between titanium and mica. Therefore, there is a phase lag between these two events of reflection of light. When, however, the amount of titanium dioxide is small as in the case of powder mica used in white pearl coating, the phase lag is almost negligible and a nearly total reflection takes place, giving a pearl white luster tinted by mica.

In interference pearl coating, the thickness of titanium dioxide coating on powder mica is increased to make the phase lag longer so that colours may be developed by interference of light. When the coating is thin, light of short wave length is damped and that of long wave length is amplified. This tendency is reversed when the coating is thick. As the coating thickness increases, the colour changes from white to gold (yellow), red, purple, blue and green in that order.

- Toscana black: Interference blue mica

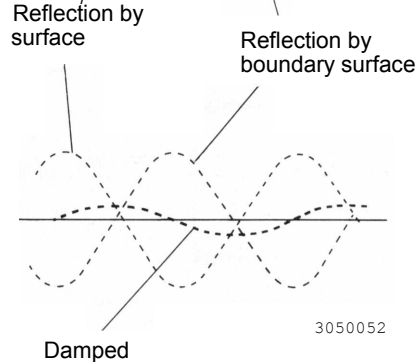
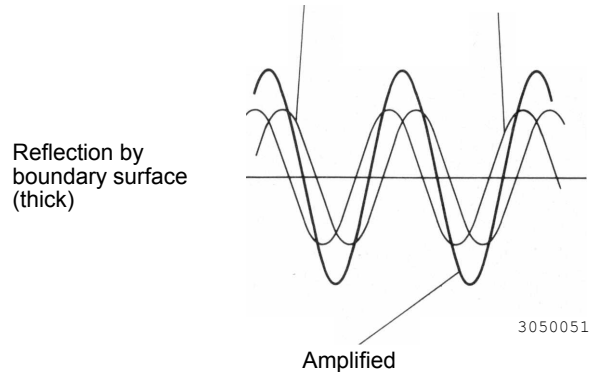
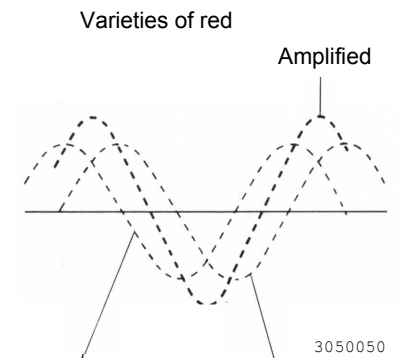
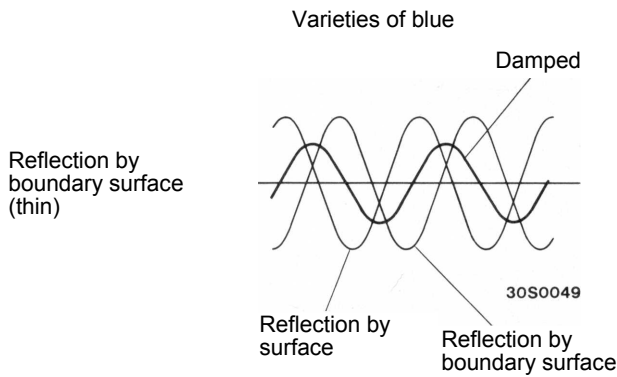
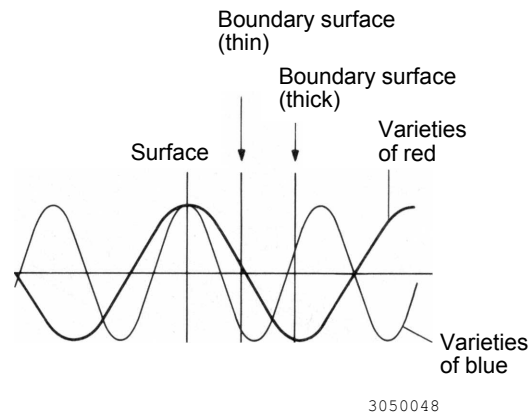
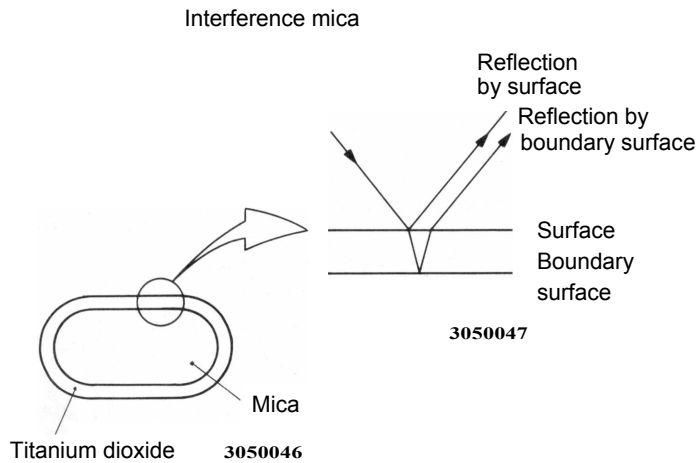

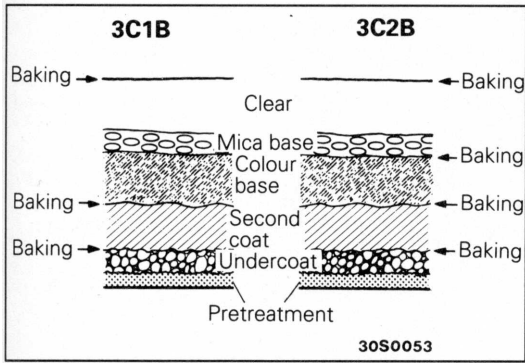

3C1B PEARL COATING

The 3-coat pearl coating so far effected by 3C38 (3-coating and-2-baking method) has been made possible by 3C1B (3-coating-and-1-baking method).

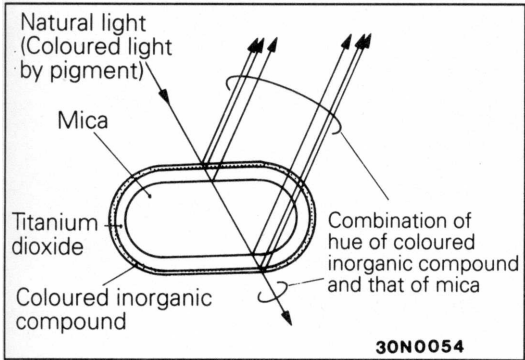

COLOURED PEARL COATING

The powder mica surface coated with titanium dioxide is further coated with coloured inorganic compound for its colouring. The hue is determined by combination of the hue of powder mica (base) and that of the coloured inorganic compound used.

- Kutani red: White mica powder coated with a strong red-coloured iron oxide is in use.

BODY COLOUR CHARTS

(M): Metallic paint
(P): Pearl paint

Body colour code		Colour	Colour number	Body colour name	Composition of film	Engine compartment and luggage compartment colour	
						Colour number	Colour
W29	WHITE	AC11029	Misty White (P)	White pearl (3C1B)	AC11064	LIGHT GRAY	
X02	BLACK	AC11002	Toscana Black (P)	Interference pearl (2C1B)	AC10903	BLACK	
R25	RED	AC10925	Kutani Red (P)	Coloured pearl (2C1B)	AC10632	MAROON	
R71		AC11071	Passion Red	Solid	AC10795	RED	
B34	BLUE	AC11034	Mariana Blue (P)	Coloured pearl (2C1B)	AC11066	BLUE	

Paint used by manufacturer

AIR PRESSURE NOISE REDUCTION

FLUSH SURFACE

Measures were taken to improve the feeling of quality and to reduce air resistance and air noise by making all parts matched with flush surface. Furthermore, indentations of the vehicle underbody have been

drastically reduced to improve the air pressure effect by regulating the flow under the floor.

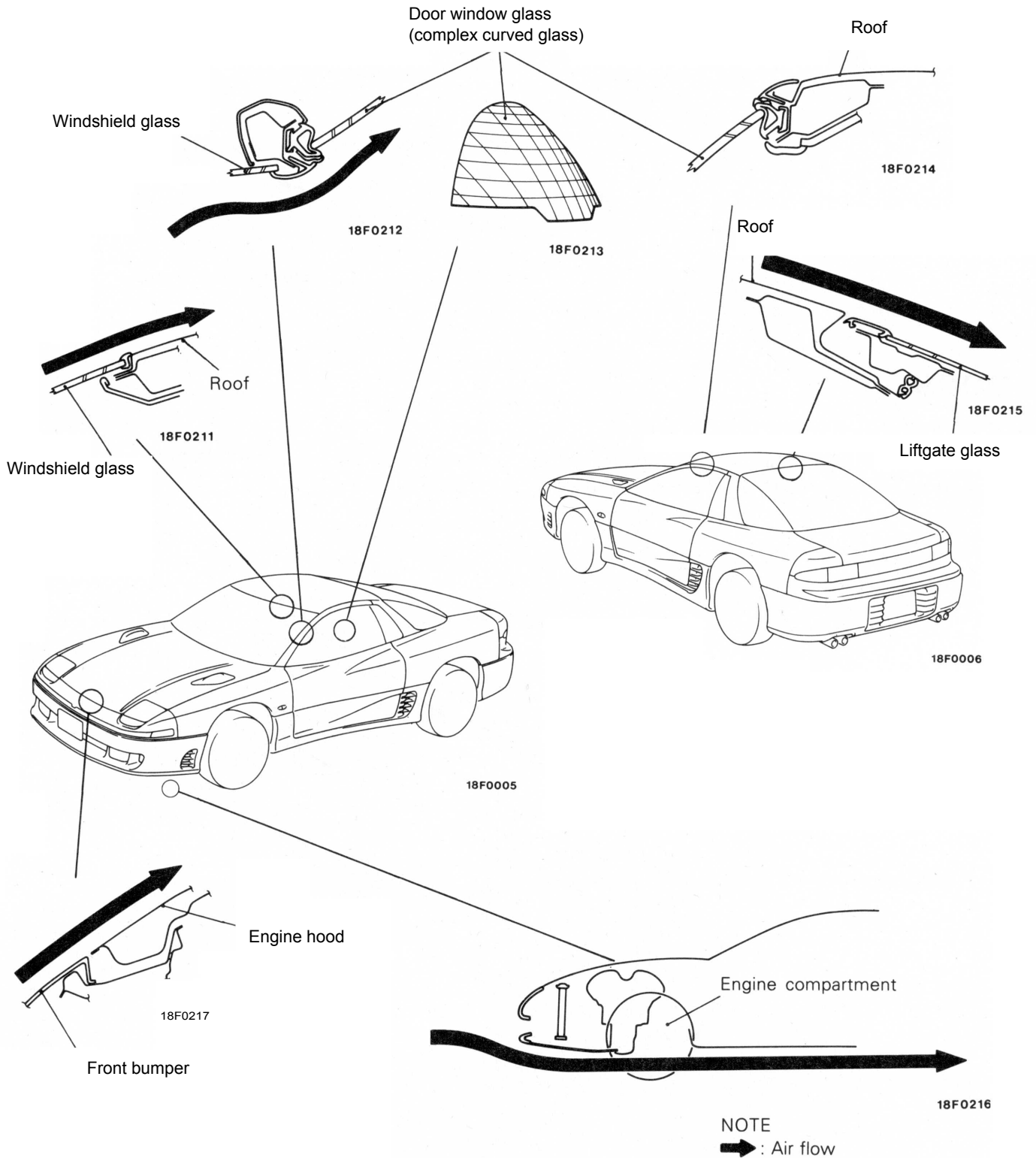

Since the door glass is sucked out by the vacuum caused by air flow when driving at high speed, a full glass catch is mounted to the weather-strip holder in order to press the door glass in place. As a result, a

good seal between the drip line weather-strip and the door glass is assured and the sucking noise when driving at high speed is shut down.

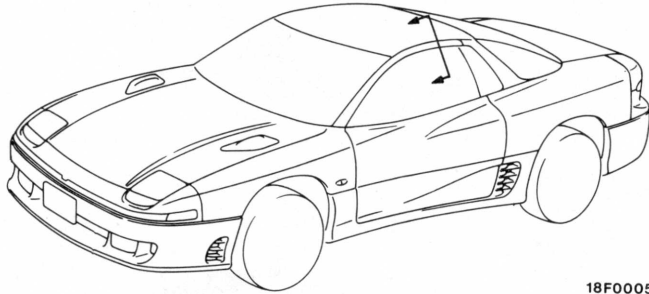

18F0005

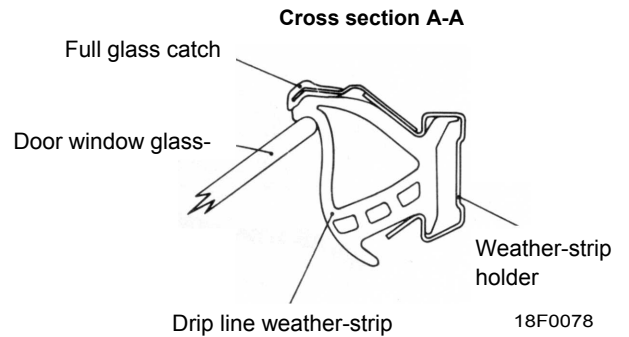

18F0078

DOORS

DOOR PANEL

A sashless door is used. Furthermore, rigidity of the outside panel is improved by efficient use of a light-

weight side door beam made of pipe and reinforcements.

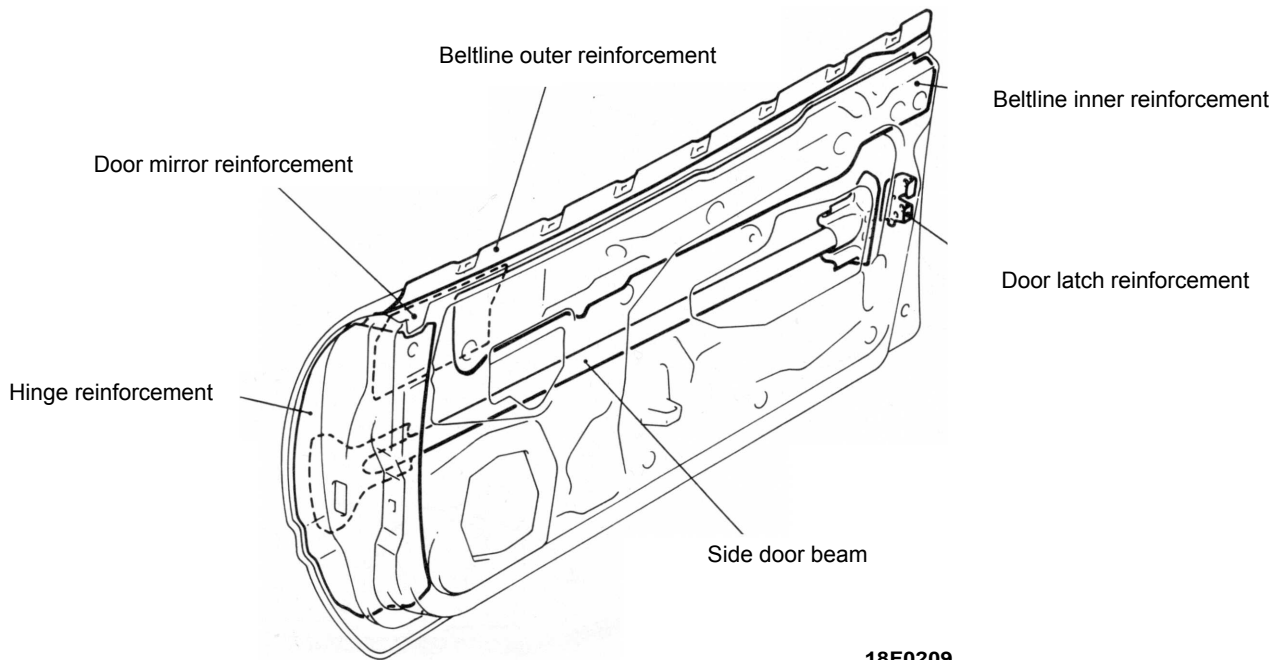

18F0209

DOOR LOCK

A roller type 2-step door check is used on all models which improves the operational feel when opening and closing the door and it holds the door securely at the midway position.

The door latch is rubber coated to improve the operation feel and for less noise when opening and closing the door.

Central door locking with a key reminder system has been adopted so that all doors can be locked and unlocked by means of the driver's side inside lock knob or by the door lock key.

NOTE

Refer to GROUP 54 - ETACS for central door locking.

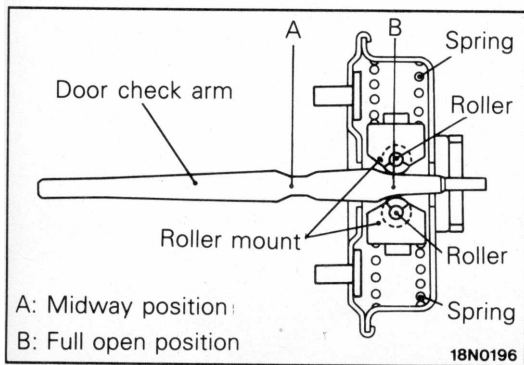
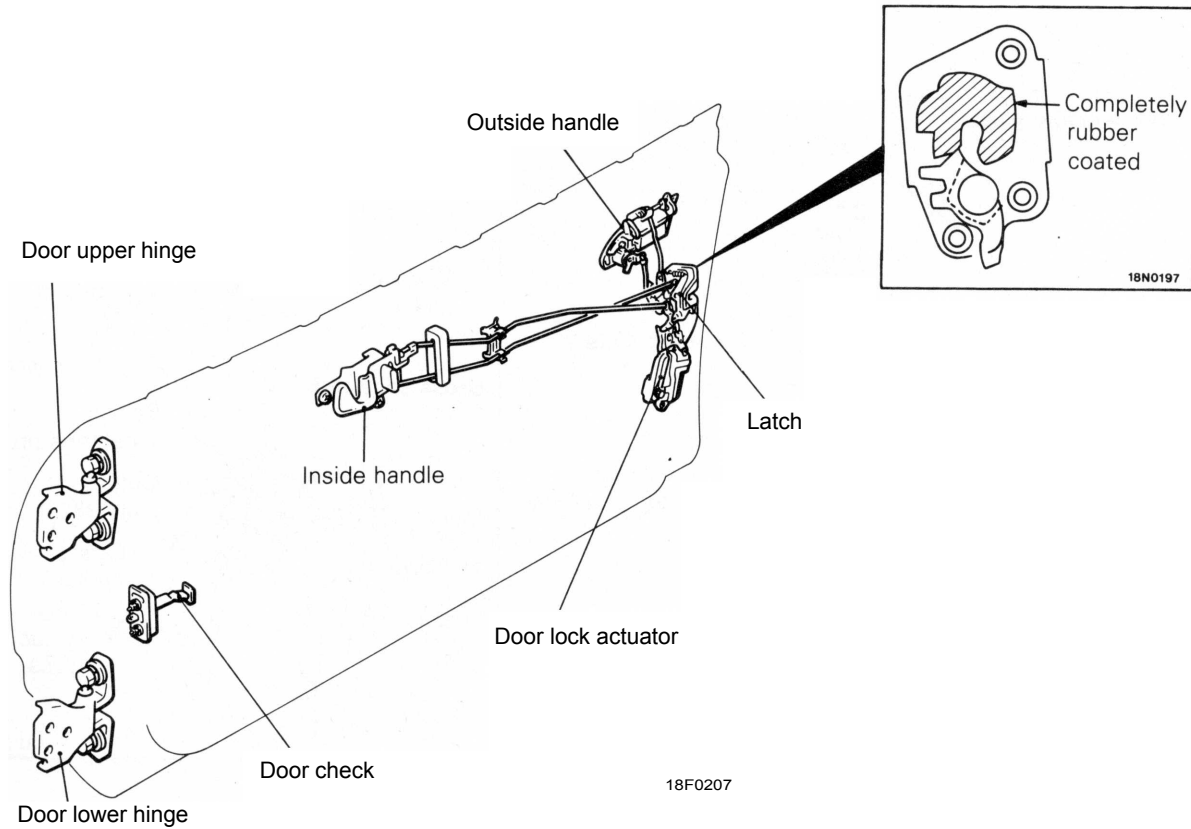

OPERATION OF DOOR CHECK STRAP

It is made so the rollers which can rotate in the door check arm is pushed up and down by the spring.

When the door is opened/closed and the roller reaches the indented position in the door check arm, the door can be held securely in the opened position.

Because the roller rotates, the operational feeling is good when opening/closing the door.

WINDOW GLASS REGULATOR

A wire winding system is used in the window glass regulator. Power windows which use a wire winding system in the window glass regulator are equipped on all models. Furthermore, the amount of lateral movement of the window glass regulator carrier plate is increased so the lateral deflection of the glass which happens when opening and closing the complex curved glass door window can be absorbed. In

order to prevent the glass from getting scratched, a glass striker is mounted on the outside of the door glass so the beltline weather-strip outer stabilizer is only effective when the window is fully closed. When the window is fully closed, the glass striker is inserted between the outer stabilizer and door glass and firmly presses the door glass.

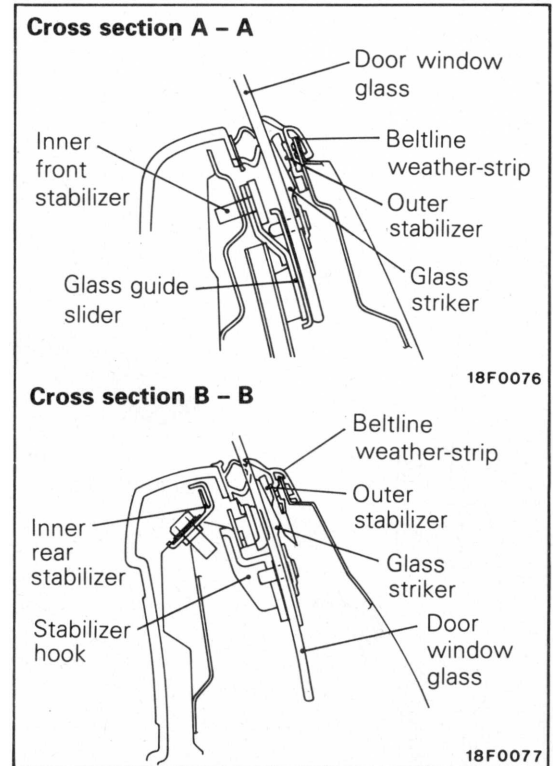
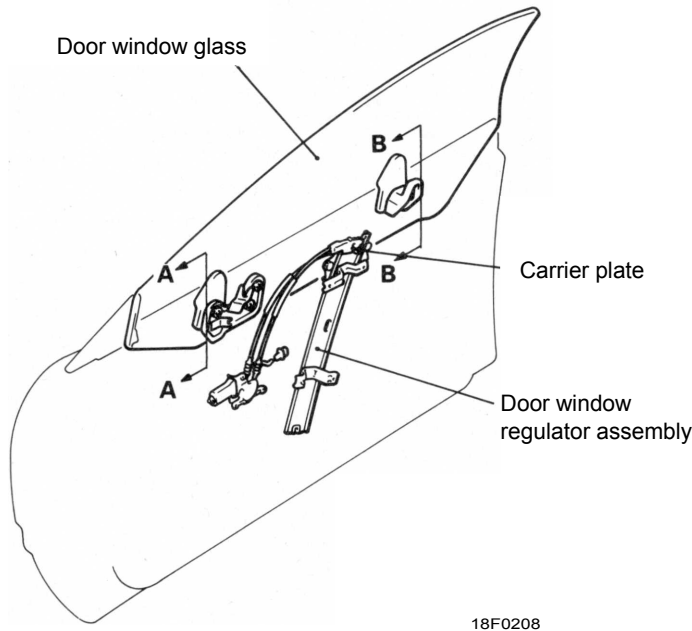

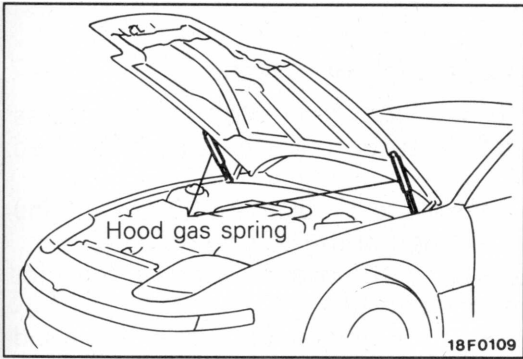

**LID
HOOD**

Since the hood has been enlarged, a gas type spring is used to reduce the force needed for opening and closing it.

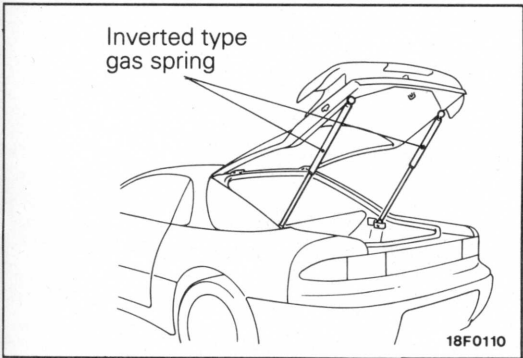

TAILGATE

The tailgate uses an inner hinge system with inverted gas springs.

Furthermore, a cable type tailgate opener is used for all models.

WINDOW GLASS

- An adhesive method is used to mount the windshield glass, quarter window glass and tailgate glass.
- Laminated glass is used for the windshield glass and reinforced glass is used for the door window glass, quarter window glass and tailgate glass in order to improve safety.
- In order to preserve the image of a capsule cabin, complex curved glass is used for the door window glass.

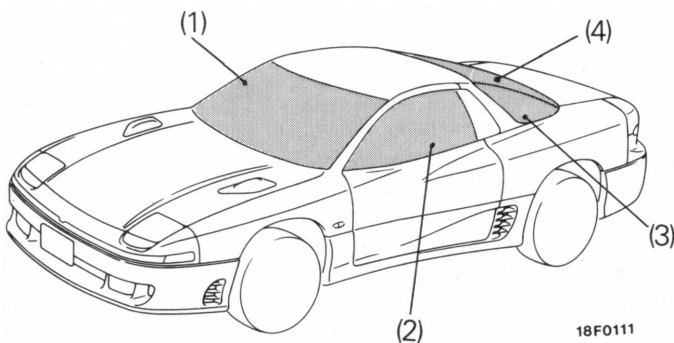

Name	Thickness mm (in.)
(1) Windshield glass	5.3 (0.21)
(2) Door window glass	5.0 (0.20)
(3) Quarter window glass	3.5 (0.14)
(4) Tailgate glass	

SUNROOF

A tilt-up and detachable sunroof with excellent lighting ability and a feeling of space and made from strengthened glass has been adopted, thereby providing improved comfort.

This sunroof has the following features.

- Adoption of a sunroof regulator which enables the sunroof tilt to be adjusted to any desired angle (Tilting is possible to a maximum 50mm (2.0 in.) from the rear edge of the sunroof.)
- Equipped with a removable sunroof trim for blocking strong sunlight
- Equipped with a deflector for preventing wind drag when the sunroof glass is removed

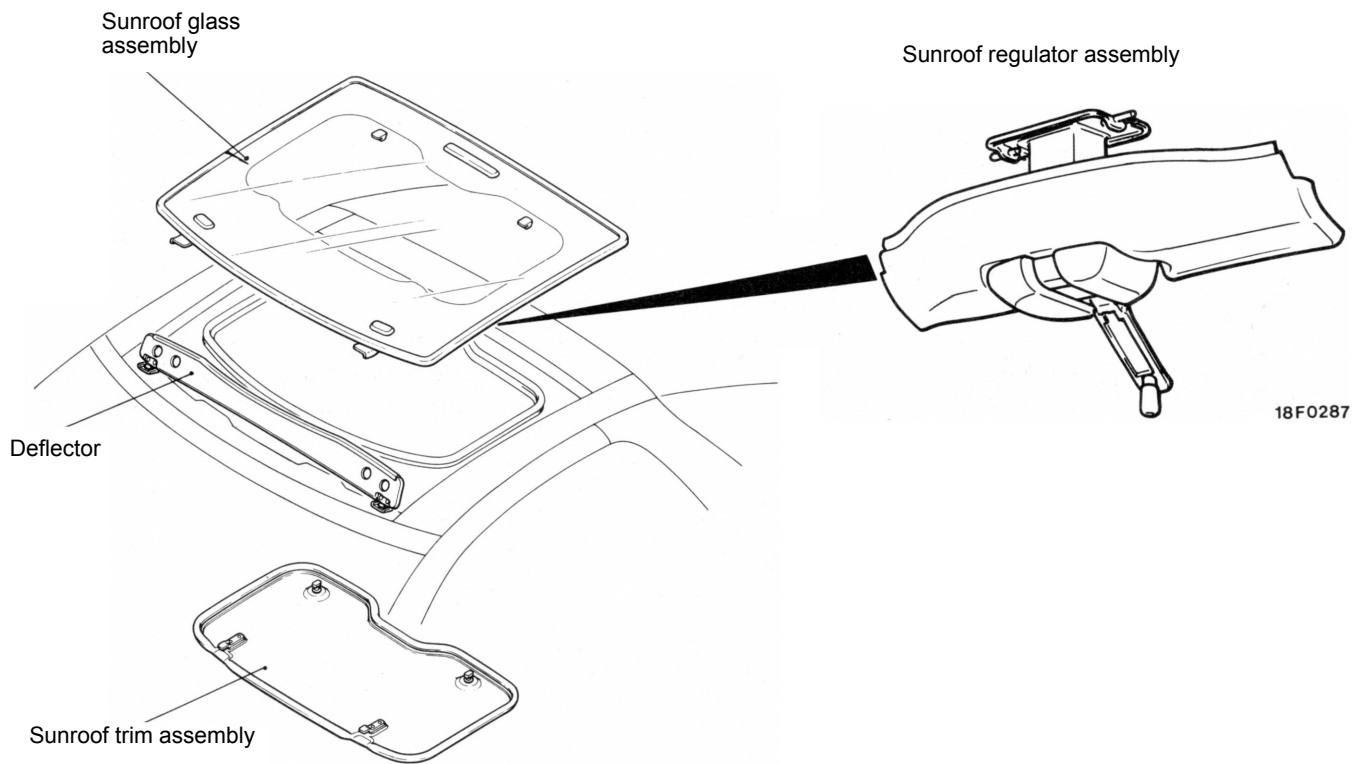

EXTERIOR

CONTENTS

SUMMARY OF EXTERIOR PARTS	2	ACTIVE AERO SYSTEM	6
BUMPERS	3	Construction Diagram	7
DOOR MIRRORS	4	Construction and Operation	8
AERO PARTS	5		



SUMMARY OF EXTERIOR PARTS

Large resin bumpers have been adopted on both the front and rear in all vehicles to emphasize the sporty look. Together with this, an air intake side air dam and a fixed type rear spoiler have also been equipped to provide improved aerodynamic characteristics.

In addition, an active aero system that operates at vehicle speeds of 80 km/h (50 mph) or more has also been provided.

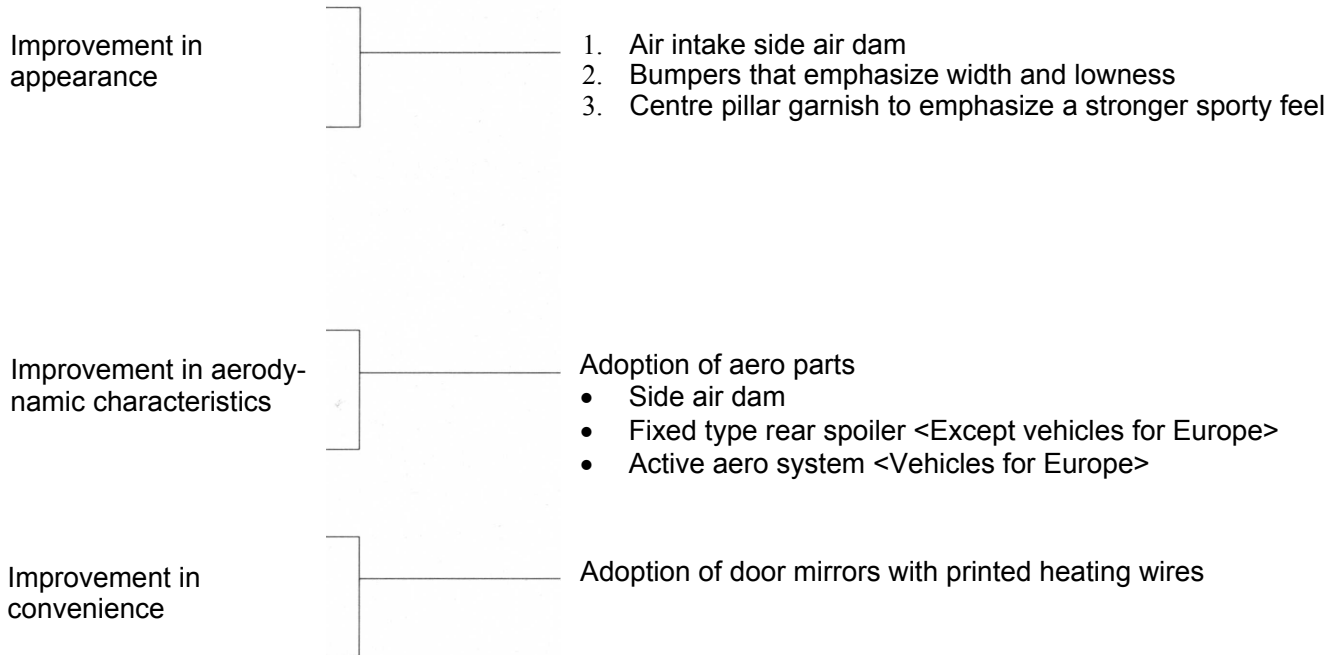

BUMPERS

Bumpers that seem to be an integral part of the body are installed.

- To improve safety, both front and rear bumpers have built-in bumper absorbers to absorb shock.
- The side of the front bumper bends around to the wheel cut and line up with the fender so that the flash surfaced body is realized.

- TPO (Thermo Plastic Olefin elastomer) is used as the material for the bumper face and, by improving molding precision, it seems to be one unit with the body with no gaps between bumper and body.

<Front Bumper>

<Rear Bumper>

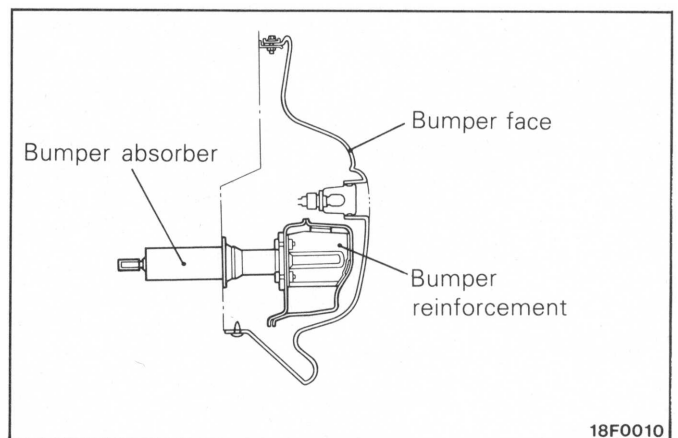
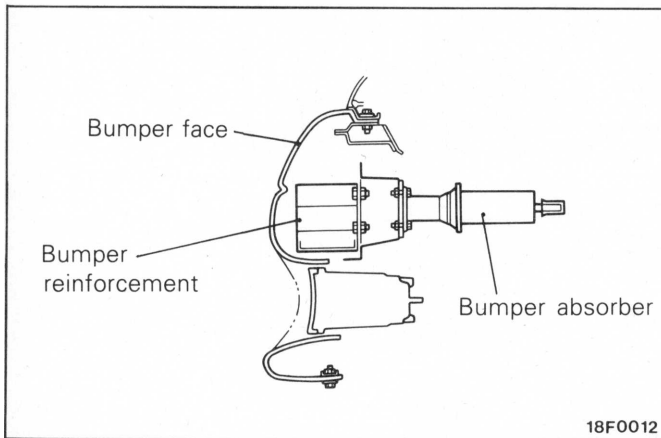
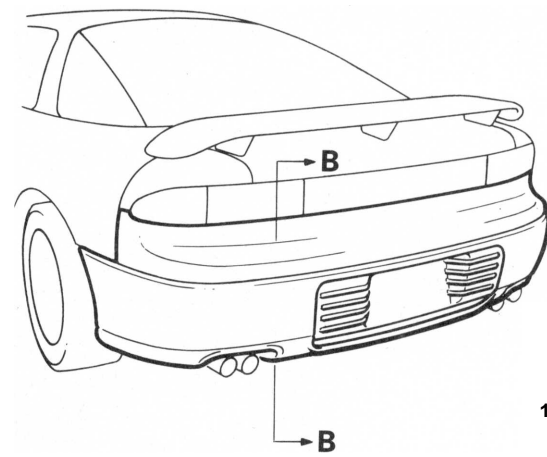
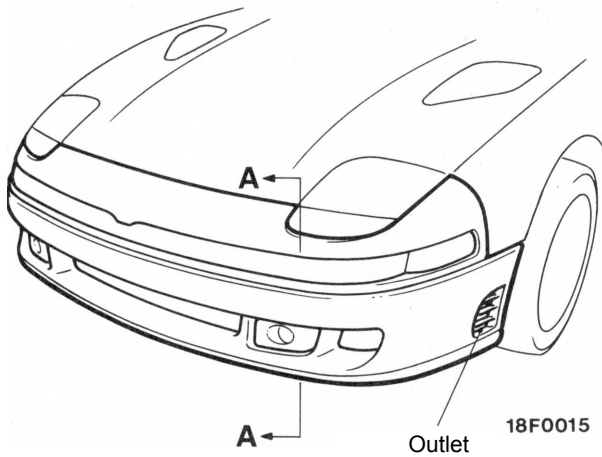

DOOR MIRRORS

The door mirrors are collapsible types with a sporty and aerodynamic design.

- The door mirror is installed a little away from the front pillar (off-body type) which takes into consideration the slanted field of view to the front.
- All models are equipped with the electric remote control mirror. The electric remote control switch is installed on the left side of the instrument panel.
- Door mirrors with printed heating wire are adopted on some models to clear frost and dew, etc. from the surface of the mirror.

MECHANISM OF DOOR MIRROR WITH PRINTED HEATING WIRE

There is a printed heating wire inside the mirror. When the rear window defogger switch is turned ON, it operates under the control of the ETACS for

approximately 11 minutes along with the rear window defogger.

For details, refer to GROUP 7 - ETACS.

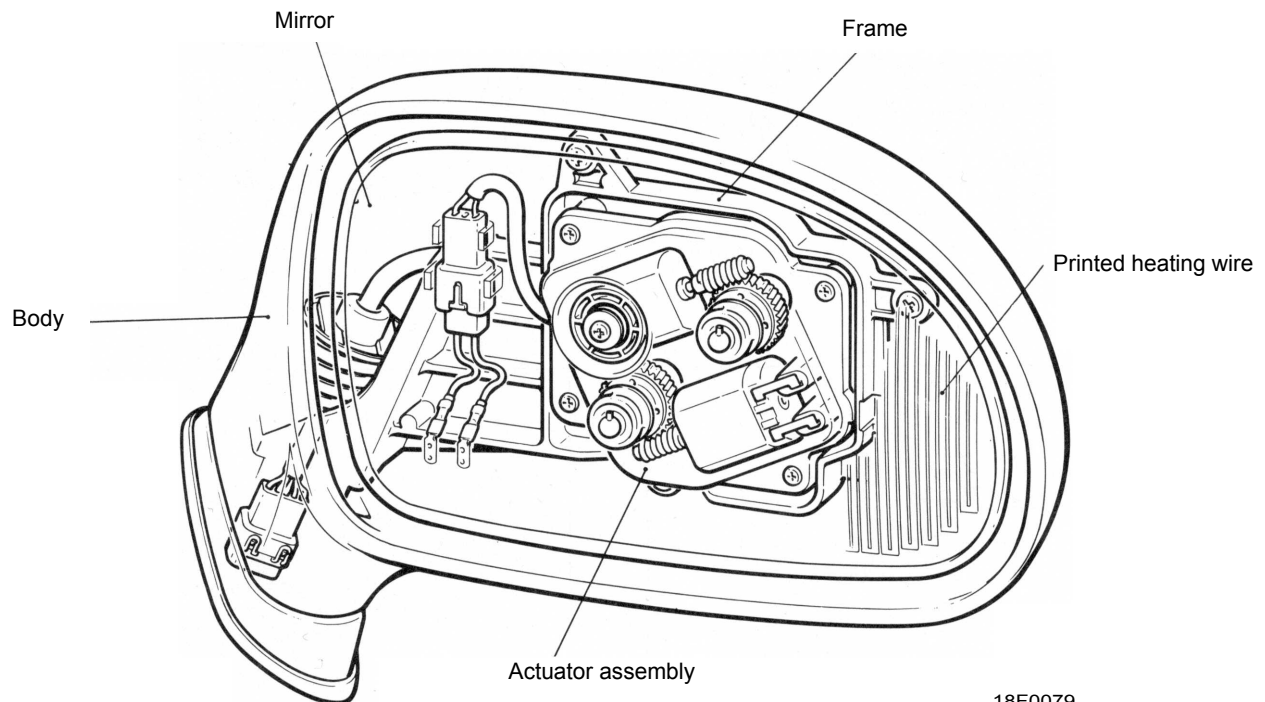

18F0079

AERO PARTS <Except vehicles for Australia>

The following aero parts are used to improve aerodynamic characteristics and marketability.

- Fixed type rear spoiler to improve the aerodynamic characteristics of the rear of the vehicle.
- A side air dam is installed to improve the aerodynamic characteristics of the side of the vehicle.

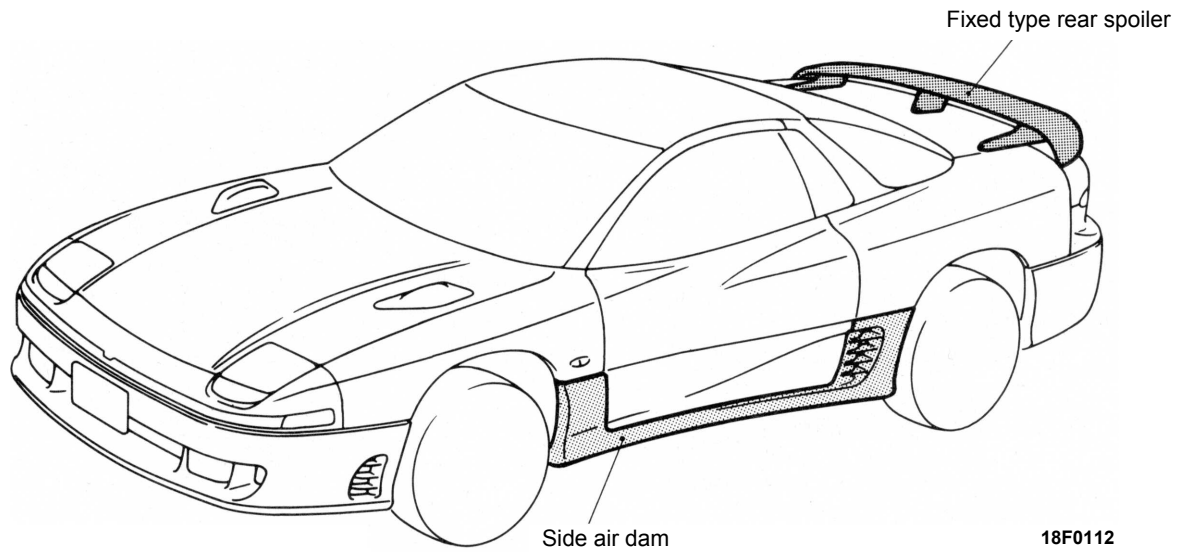
<Small Type>

18F0112

ACTIVE AERO SYSTEM <Vehicles for Europe and General Export>

In order to improve aerodynamic characteristics when driving at high speed, a variable front venturi skirt and a variable rear spoiler which automatically move to the operated positions at vehicle speeds of 80 km/h (50 mph) or more and automatically 'move back to the standard positions at 50 km/h (31 mph) or less are equipped.

This active aero system has the following features.

- Front wheel lifting force has been reduced by means of the front venturi skirt, and rear wheel

lifting force has been reduced by means of the rear spoiler.

- A function is provided to set the aero parts to the standard positions when driving on poor road surfaces, and to the operated position at times such as when washing the vehicle.
- A deflector has been provided on the rear spoiler to prevent dirtying of the rear of the vehicle by sand, etc.
- A high-mounted stop lamp has been equipped on the rear spoiler. <L.H. drive vehicles>

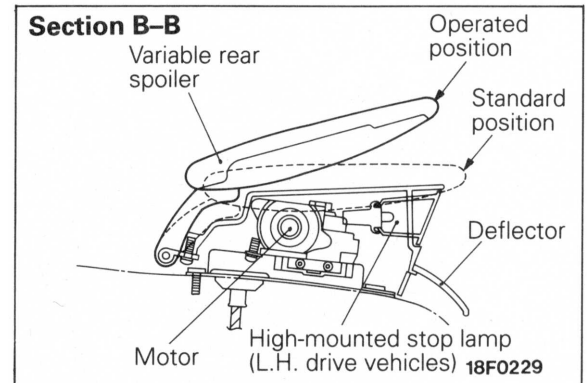
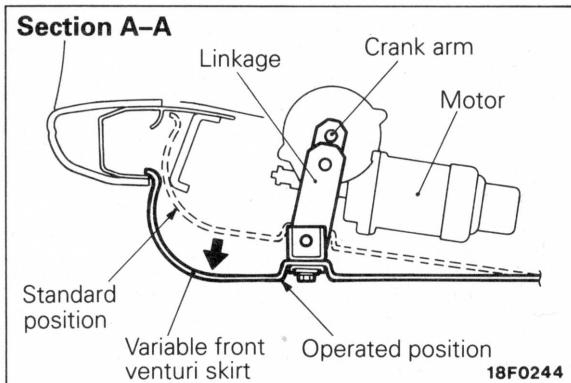
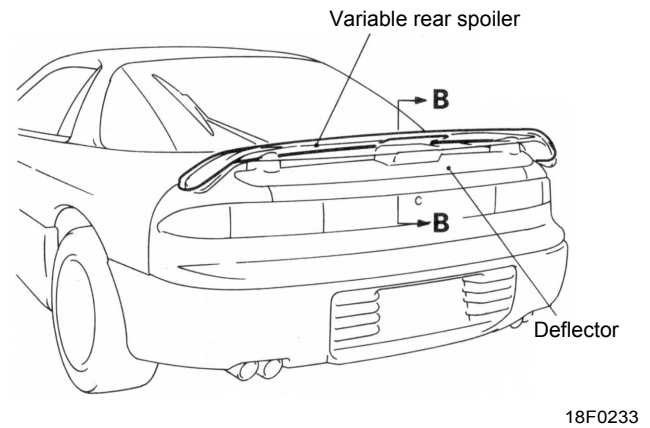
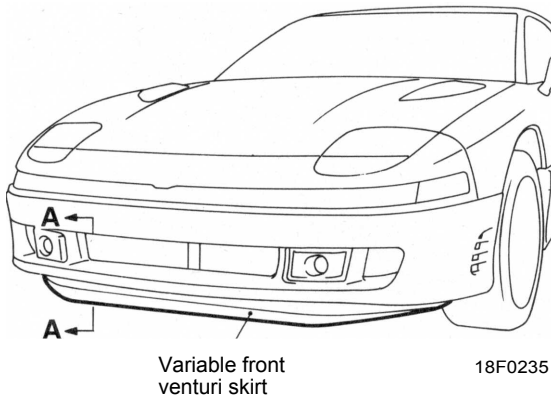

CONSTRUCTION DIAGRAM

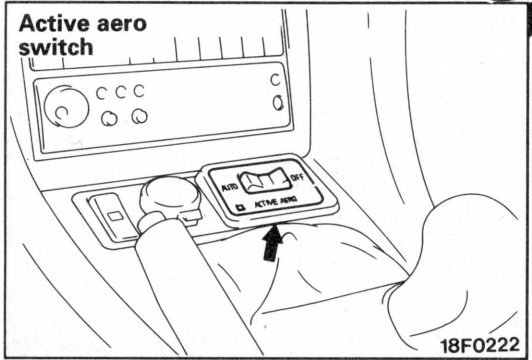
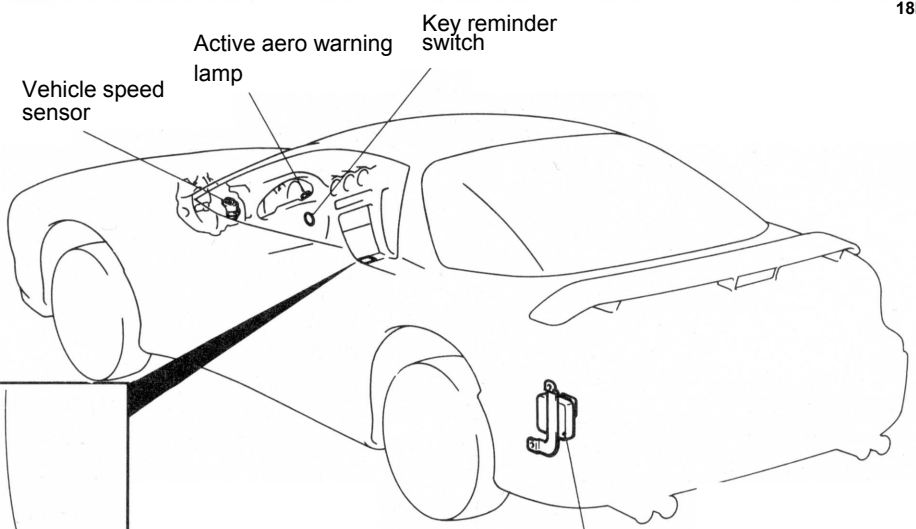
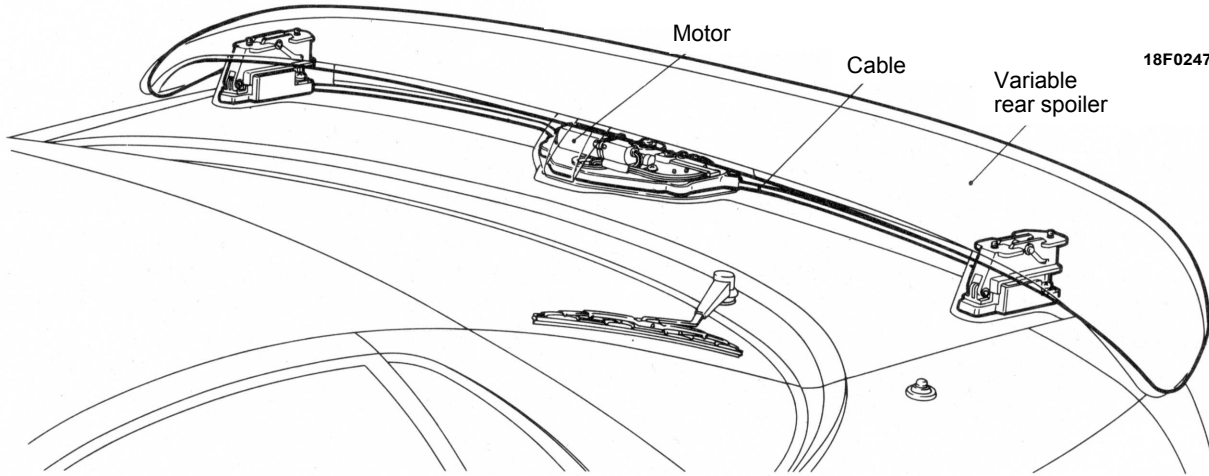
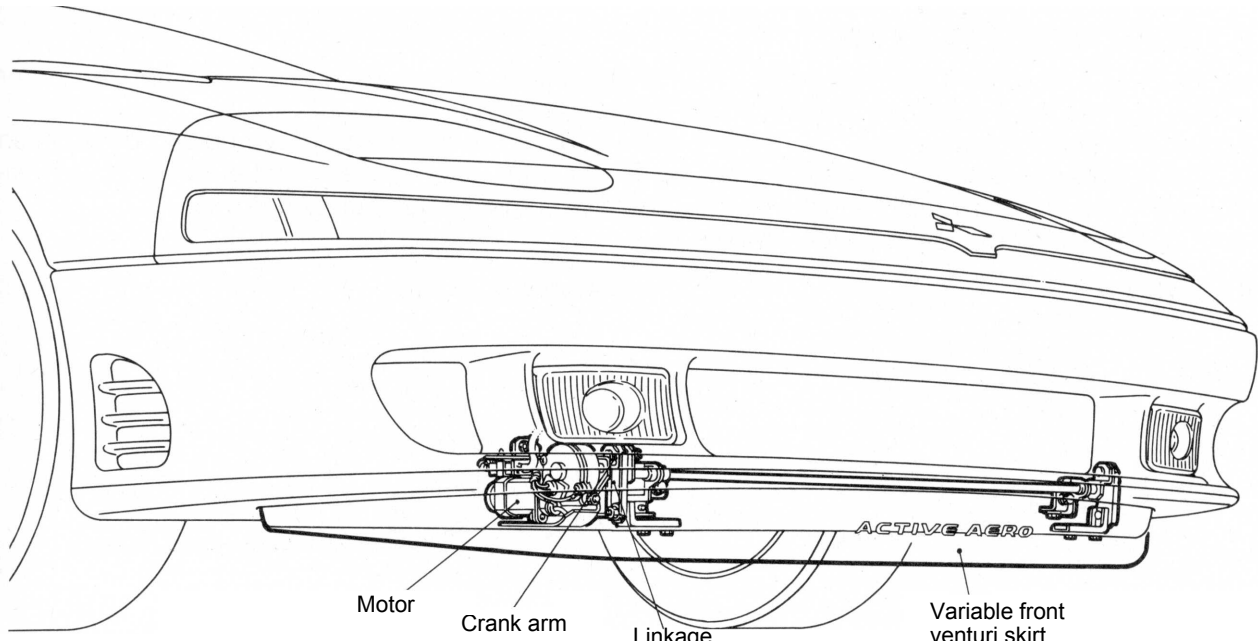

18F0301

CONSTRUCTION AND OPERATION

VARIABLE FRONT VENTURI SKIRT

The motor is mounted on the front end crossmember, and the motor and the front venturi skirt are connected via a crank arm and a linkage. When the motor operates, the crank arm turns while pushing the linkage. Then, when the skirt is in the operated position or the standard position, the limit

switch inside the motor turns OFF and the motor stops operating. This causes the linkage to move up and down in an elliptical path, moving the front venturi skirt approximately 50 mm (2.0 in.) up and down.

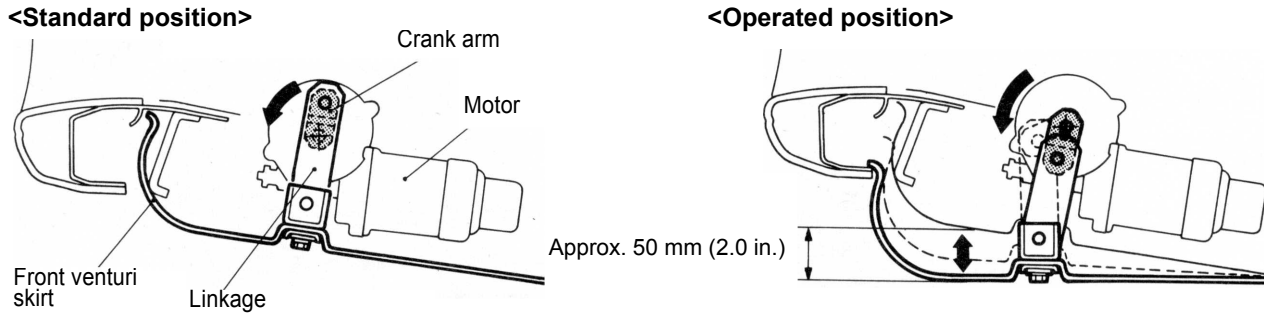

18F0245

18F0246

VARIABLE REAR SPOILER

Operation mechanism

The motor in the centre stay of the spoiler turns the drive gear which operates the cable. When the slider is pulled by the cable due to this action, pin A of the slider moves to the rear of the oblong hole in the guide, so that the rear edge of the spoiler lifts pin B to the support point in accordance with the shape of the oblong hole, and the spoiler is tilted forward

approximately 15°. In addition, when the motor is reversed, the slider is pushed by the cable and the spoiler is lowered by the reverse operation to that of lifting. Then, when the operated position or standard position is reached, the limit switch inside the motor turns OFF and the motor stops operating.

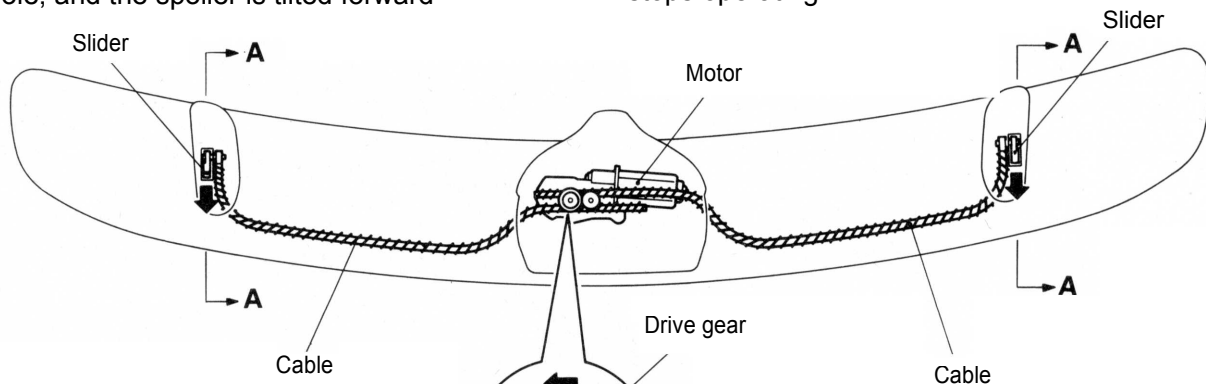

Section A-A

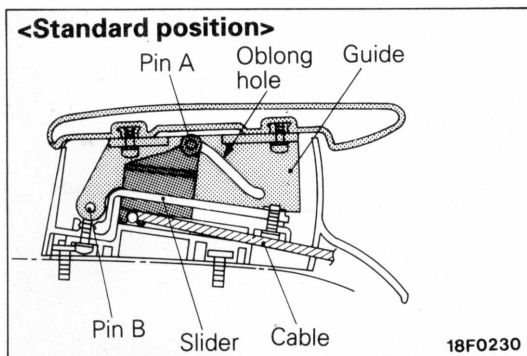

18F0230

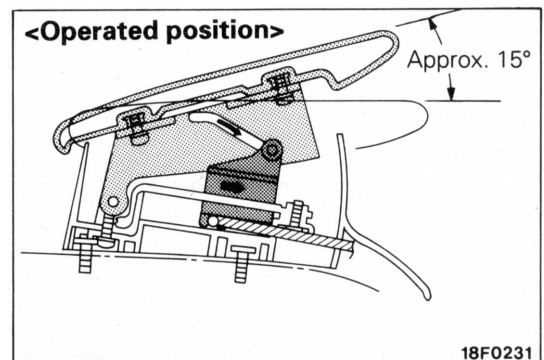

18F0241

18F0231

DEFLECTOR

The deflector that is located on the rear spoiler prevents dust from being drawn up from underneath the vehicle and dirtying the rear of the vehicle by increas-

ing the air flow speed over the rear surface of the vehicle.

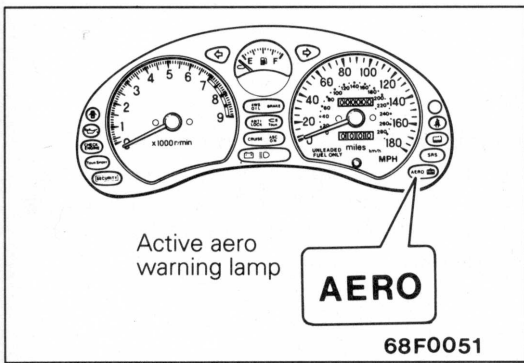
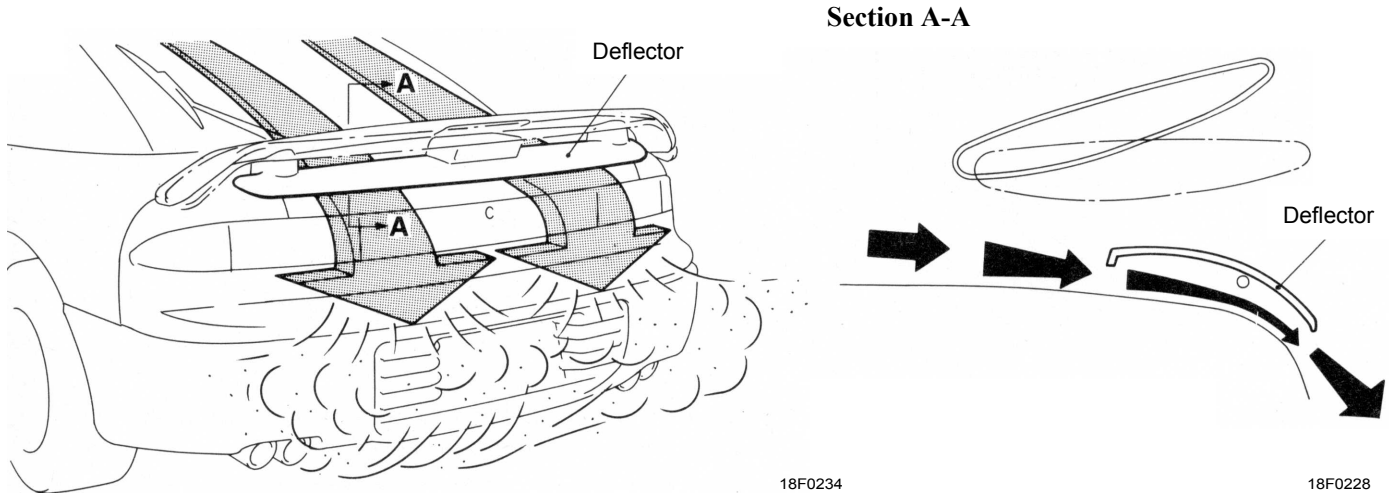

ACTIVE AERO WARNING LAMP

Illuminates at the following times:

- (1) For 3 seconds when the ignition switch is turned from OFF to ON.
- (2) When the following problems occur with the front venturi skirt.
 - When the front venturi skirt does not fully return to the standard position due to blocking by foreign particles or freezing, etc.
 - When front venturi skirt does not return to the normal standard position due to a defective limit switch.

Re-output function when there is a malfunction

When the front venturi skirt and rear spoiler are not fully in the operated position or the standard position, the active aero control unit outputs a signal after 0.5 seconds, as shown in the illustration at left, to re-operate the motor.

If the skirt and spoiler are still not in the fully operated position or standard position after this second output signal, output stops. However, when the front venturi skirt has returned to the standard position, the signal will be output a maximum of three times.

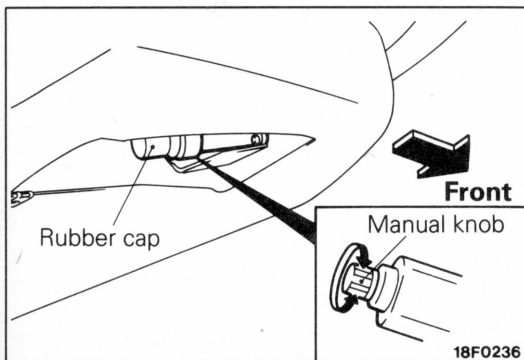
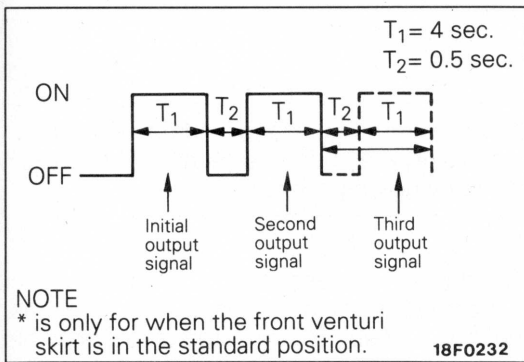

Manual operation of the variable front venturi skirt

If the front venturi skirt has not fully returned to the standard position, carry out the following procedure.

- (1) Remove the cover at the right of the front venturi cover.
- (2) Remove the rubber cap at the back of the motor.
- (3) Turn the manual knob either to the left or the right to return the skirt to the standard position.

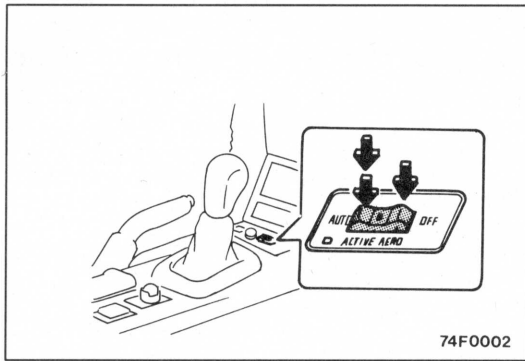



ACTIVE AERO SWITCH

The active aero switch has three contact positions: AUTO1, AUTO2 and OFF. The front venturi skirt and rear spoiler move to the operated position and the standard position in accordance with the position of this switch and the vehicle speed.

In addition, this switch has an operating indicator that indicates the operated position.

The operation of the active aero system is conditional on the ignition key being inserted into the ignition key

cylinder. If the key is removed, the system returns to the standard position.

Active aero switch	Operating conditions	Remarks
<p>AUTO1</p> 	<p>When the vehicle speed is 80 km/h (50 mph) or higher, the front venturi skirt and rear spoiler move to the operated position, and at 60 km/h (31 mph) or less, they return to the standard position.</p>	<p>Driving stability at high speeds is improved.</p>
<p>AUTO2</p>  <p>Press down fully (Self-return type)</p>	<p>When the vehicle is stopped, if the active aero switch is set to AUTO2, the front venturi skirt and rear spoiler move to the operated position. However, because the switch is a self-return type, it will move from the AUTO2 position back to the AUTO1 position. Because of this, the front venturi skirt and rear spoiler will return to the standard position at a vehicle speed of 2 km/h (1.2 mph) or more, and after that they will operate according to the AUTO1 setting.</p>	<p>Use this when washing the front venturi skirt and rear spoiler, or when checking their operation. If the switch is set to OFF or the ignition key is removed, they will return to the standard position.</p>
<p>OFF</p>  <p>74F0026</p>	<p>The front venturi skirt and rear spoiler are always in the standard position.</p>	<p>Use when there is a danger that the front venturi skirt may become damaged, such as when driving on poor road surfaces.</p>

NOTES

- (1) When driving at speeds of 2 km/h (1.2 mph) or above, the AUTO2 setting on the active aero switch is not effective.
- (2) There may be cases where the active aero system does not operate due to strong winds or freezing. At such times, stop the vehicle, (unfreeze the frozen section), remove the ignition key and then re-insert it. This will make it possible to operate the system.

Operation circuits

Moving from standard position to operated position

When the front venturi skirt and rear spoiler are in the standard position, each drive circuit outputs a vari-

able signal in cases 1 and 2 for the following order of conditions 1 and 2.

		Condition 1	Condition 2	
		Key reminder switch	Active aero switch	Vehicle speed sensor
Case 1	OFF		AUTO 1	80 km/h (50 mph) or more
Case 2	(Ignition key is inserted into the ignition key cylinder)		AUTO 2	Vehicle stopped

Because the operation of each limit switch is as shown in the tables below, the DOWN side and SLANT side are ON in the standard position and there is continuity.

Because of this, the front venturi skirt drive circuit turns transistor Tr2 ON, thereby turning the contact of relay 1 ON. This causes current to flow from fusible link (11) to the relay 1 contact, motor and earth, operating the motor and moving the front venturi skirt to the operated position.

At this time, the limit switches are also turned by the motor, and when the operated position is reached, the DOWN side contact of the limit switches becomes OFF, relay 1 turns OFF and the motor stops. In the same way, the rear spoiler drive circuit turns transistor Tr3 and relay 2 ON, operating the motor and moving the rear spoiler to the operated position. When the operated position is reached, the SLANT side of the limit switch becomes OFF, and the motor stops.

<Operation chart for front venturi skirt limit switches>

Skirt position / Limit switch	UP (Standard position)	During operation	DOWN (Operated position)
Limit switch (Up Side)	OFF	ON	ON
Limit switch (Down Side)	ON	ON	OFF

<Operation chart for rear spoiler limit switches>

Spoiler position / Limit switch	FLAT (Standard position)	During operation	SLANT (Operated position)
Limit switch (FLAT Side)	OFF	ON	ON
Limit switch (SLANT Side)	ON	ON	OFF

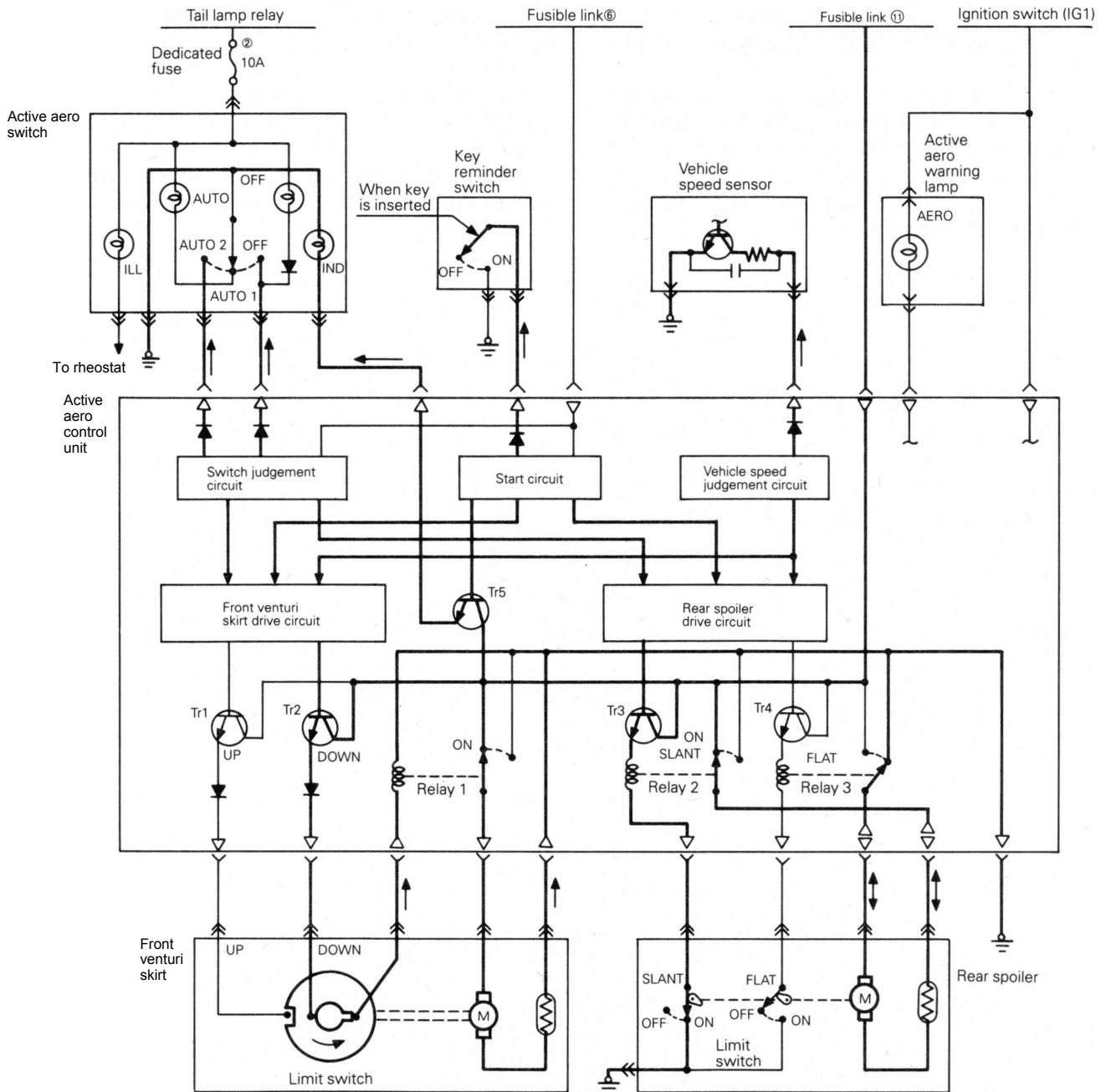

Moving from operated position to standard position

When the front venturi skirt and rear spoiler are in the operated position, each drive circuit outputs a standard

signal in any of the cases 1 - 4 for the following order of conditions 1, 2 and 3.

	Condition 1	Condition 2	Condition 3
	Key reminder switch	Active aero switch	Vehicle speed sensor
Case 1	ON (Ignition key is removed from the ignition key cylinder)	-	-
Case 2	OFF (Ignition key is inserted into the ignition key cylinder)	OFF	-
Case 3		AUTO 1	When decelerating to 50 km/h (31 mph) or less
Case 4		AUTO2 (automatically returned to AUTO1)	When driving off at 2 km/h (1.2 mph) or higher

Because the operation of each limit switch is as shown in the tables below, the UPSide and FLAT side are ON in the operated position and there is continuity. Because of this, the front venturi skirt drive circuit turns transistor Tr1 ON, thereby turning the contact of relay 1 ON. This causes current to flow from fusible link (11) to the relay 1 contact, motor and earth, operating the motor and moving the front venturi skirt to the standard position. At this time, the limit switches are also turned by the

motor, and when the standard position is reached, the UP side contact of the limit switches becomes OFF, and the motor stops. In the same way, the rear spoiler drive circuit turns transistor Tr4 and relay 3 ON, operating the motor and moving the rear spoiler to the standard position. When the standard position is reached, the FLAT side of the limit switch becomes OFF, and the motor stops.

<Operation chart for front venturi skirt limit switches>

Skirt position / Limit switch	UP (Standard position)	During operation	DOWN (Operated position)
Limit switch (Up side)	OFF	ON	ON
Limit switch (Down side)	ON	ON	OFF

<Operation chart for rear spoiler limit switches>

Spoiler position / Limit switch	FLAT (Standard position)	During operation	SLANT (Operated position)
Limit switch (FLAT side)	OFF	ON	ON
Limit switch (SLANT side)	ON	ON	OFF

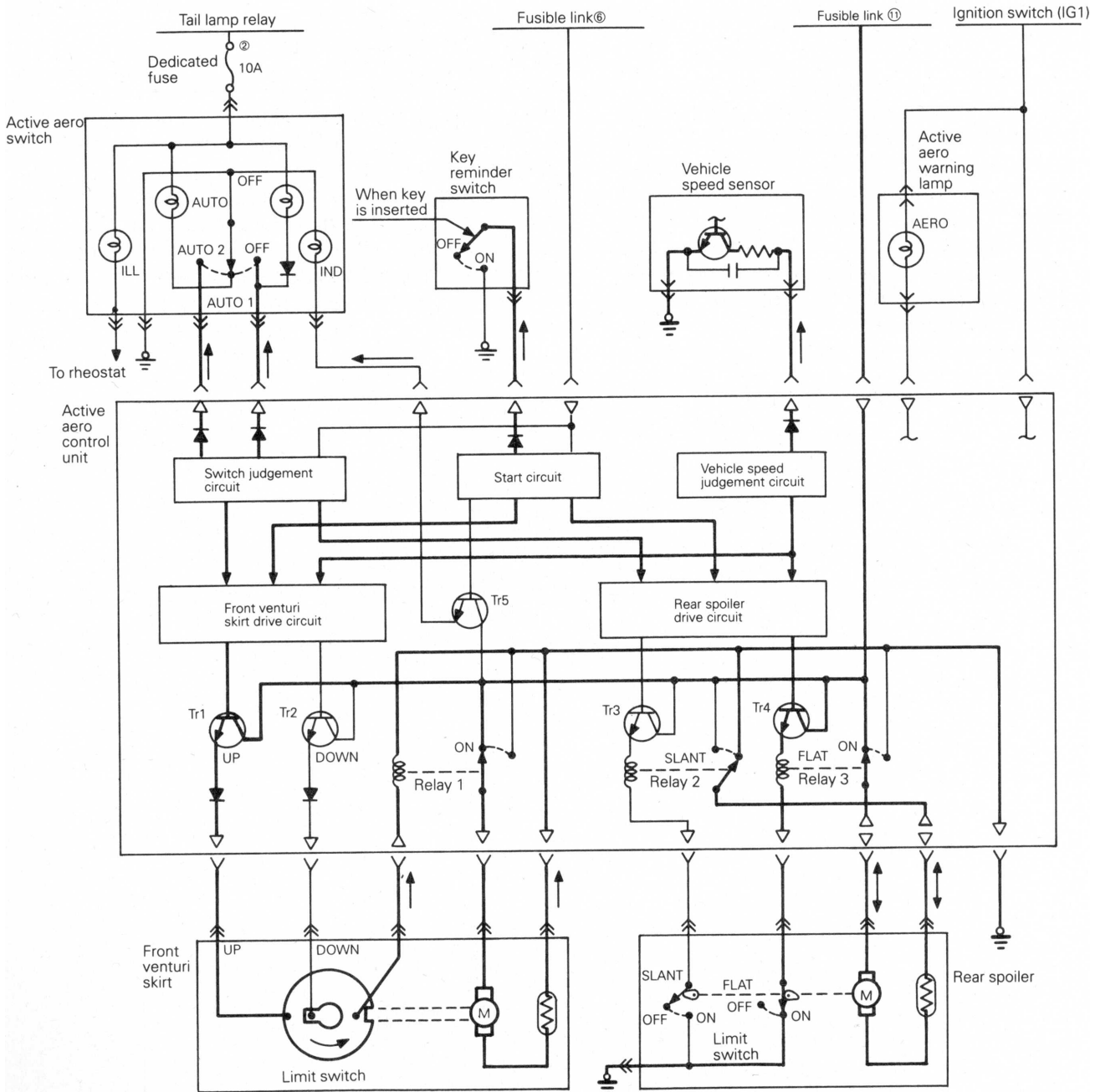

INTERIOR

CONTENTS

SUMMARY OF INTERIOR PARTS	2	SEAT BELT	9
INSTRUMENT PANEL AND CONSOLE		Construction and Operation of the	
BOX	3	Energy-absorbing Belt and the Buckle	9
SHELF COVER	3	Electric Type Low Tension Seat Belt	10
SEATS	4	<Vehicles for General Export and GCC>	
Structure Diagram	4	SUPPLEMENTAL RESTRAINT	
Construction and Operation	5	SYSTEM (SRS)	13
Head Restraint (Horizontal Adjustment		SRS Schematic	14
Mechanism)	8	Warning/Caution Labels	15
		Construction and Operation	17



SUMMARY OF INTERIOR PARTS

In addition to being easier to use, the interior parts improve the feeling of fitness and solidity and create a high-quality sports car atmosphere.

FEATURES

Improvement of quality feeling	— [<ol style="list-style-type: none">1. Full trim interior2. Round and one-unit instrument panel3. Single formed headlining4. Cubic-formed door trim
Improvement of easy use	— [<ol style="list-style-type: none">1. Large floor console2. Split type rear seat3. Automatic roll-up .type shelf cover
Convenient small storage compartments] — [<ol style="list-style-type: none">1. Ash tray (front part of console)2. Cup holder (in console box)3. Floor console box (in console box)
Improved safety	— [<ol style="list-style-type: none">1. Instrument panel pad2. Knee protector3. 3-point seat belt with ELR4. Supplemental restraint system (SRS)
Consideration of ideal driving position	— [<ol style="list-style-type: none">1. 10-way power seat (driver's seat)2. Electric type low tension seat belt (front) <Vehicles with General Export and GCC>

INSTRUMENT PANEL AND CONSOLE BOX

A round instrument panel is used, creating the feeling of being in a cockpit. The panel surface is covered with padding to improve safety.

The console box is divided into two sections, front and rear. The rear console has a large lid and there is a cup holder inside the box.

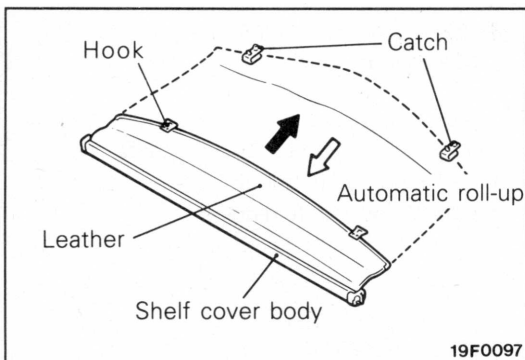
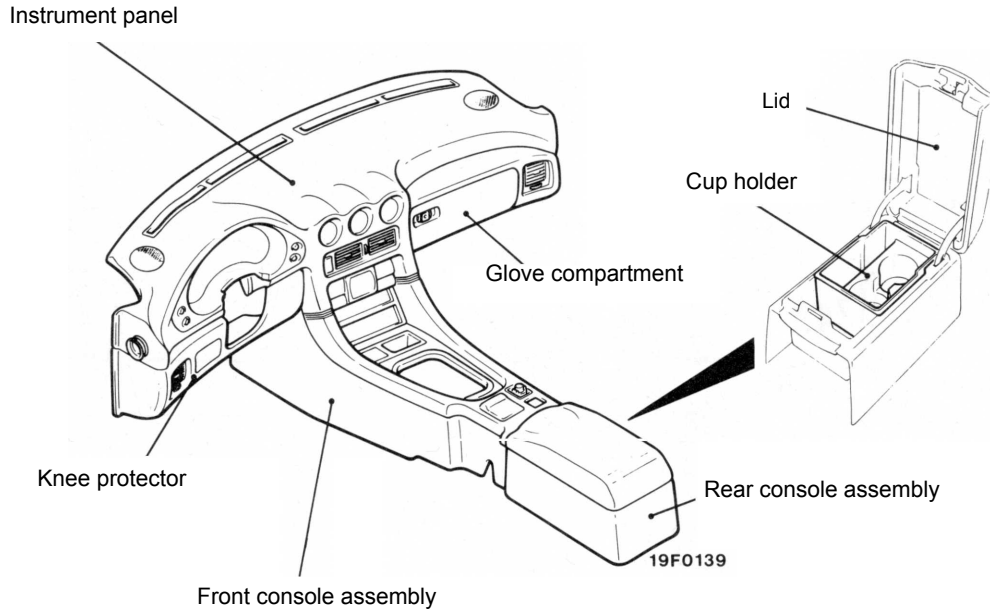

SHELF COVER

An automatic roll-up type shelf cover is used for easy use. When used, the hooks catch on the liftgate trim. When the hooks are released, a spring automatically rolls the leather into the body. The shelf cover body can be removed easily to fold-down the rear seat forward for an additional space when loading a big cargo.

SEATS

A sports type of front seat that emphasizes the feeling of being supported has been provided, and also real leather seats have been provided as an option. The sports type of seat on the driver's side is a 10-way power seat. The lumbar support, side support, dual height (front height and rear height), of the power seat can be adjusted continuously (stepless) for the ideal driving position. In addition, the reclining adjustment in the driver's seat comes with a memory. In addition

to the conventional reclining adjustment, there is a special function in this seat; when the seatback is forward-reclined and then set upright again, it fixes to the original seatback angle. The passenger's seat has a walk-in function so it is easy to get through the rear seat.

A split type rear seat for left and right being separated is adopted in order to improve functional use.

STRUCTURE DIAGRAM

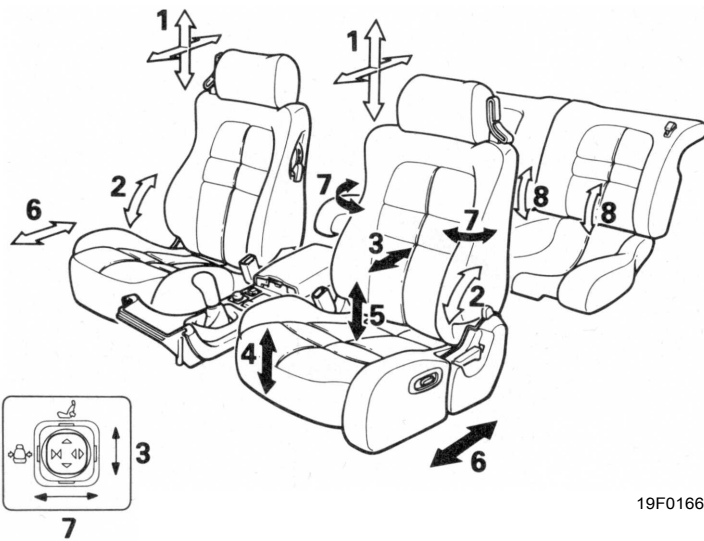

19F0166

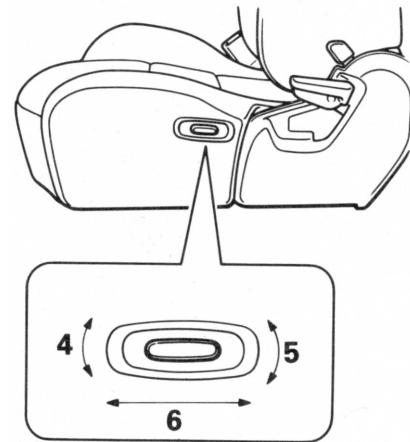

19F0031

Power seat switch A
(lumbar and side support adjustments)

Power seat switch B
(slide, front and rear height adjustments)

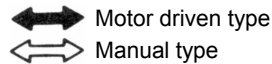

- 1. Front/back (horizontal movement) and up/down adjustment of head restraint
 - 2. Reclining adjustment (driver's seat with memory)
 - 3. Lumbar support adjustment
 - 4. Front height adjustment
 - 5. Rear height adjustment
- } Dual height adjustment

- 6. Slide adjustment (motor driven type for driver's seat)
- 7. Side support adjustment
- 8. Seatback forward-fold-down

CONSTRUCTION AND OPERATION

POWER SEAT

Lumbar Support Structure

If the switch on the front console is pushed to the front as shown in the figure, the lumbar support motor revolves, the screw nut and the arm move in the direction indicated by the arrows respectively. Then, the rod joined to the arm moves, pushing the lumbar

support plate to the front. This is a stepless, continuous stroke adjustment. In addition, if the switch is pushed to the rear, the operation is reversed.

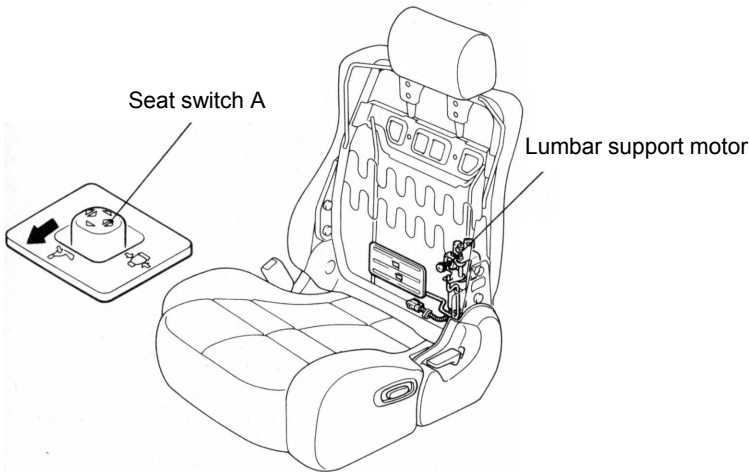

19F0146

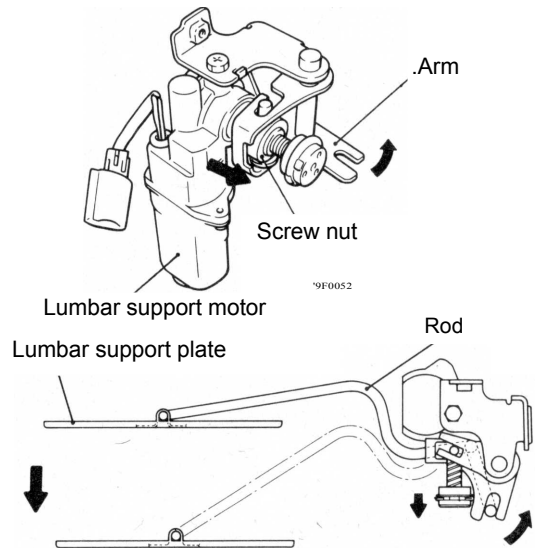

19F0064

Side Support Structure

If the switch is pushed as shown in the figure, the side support motor revolves, the screw nut and the arm move in the direction indicated by the arrows respectively. The link connected to the arm moves the connecting

rod in the direction indicated by the arrow and the side support frame moves to the inside. This is a stepless, continuous stroke adjustment. In addition, if the switch is pushed to the opposite side, the operation is reversed.

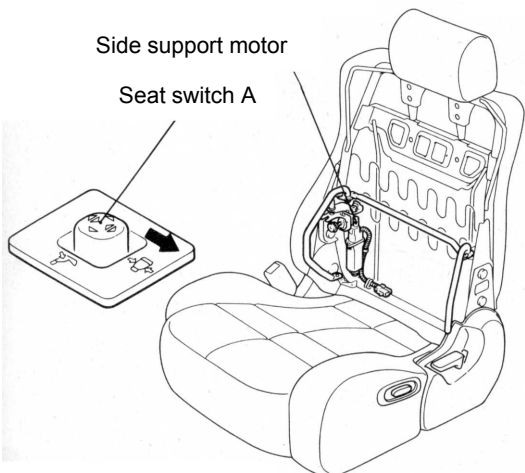

19F0145

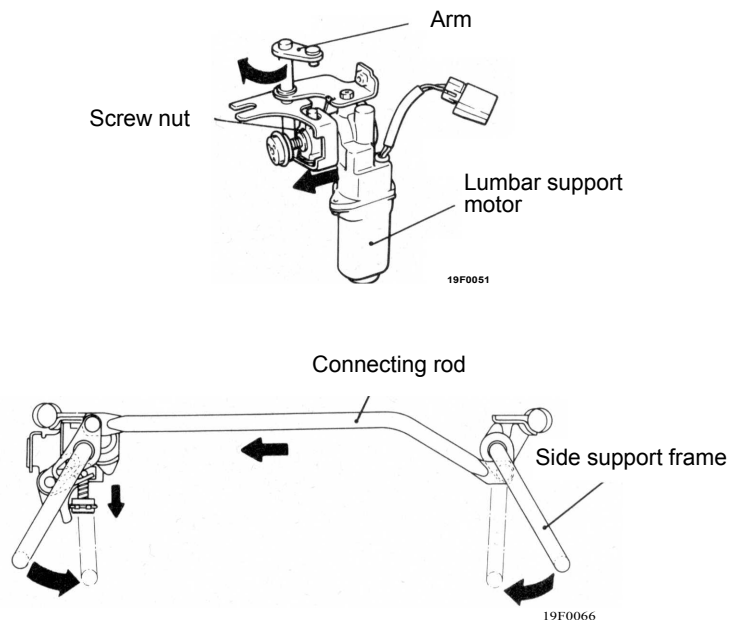

19F0066

Front Height and Rear Height Adjusting Structure

The front and rear portions of the seat cushion can be raised and lowered independently. If the front height and rear height switch is pushed to the UP side, motor revolutions will be transferred to gear A to gear B to sector gear. Since the sector gear, shaft and arm are fixed, the seat cushion rises continuously (stepless) along with the revolution of the sector gear.

As the seat cushion continues to rise, the claw on the shaft turns the limit switch from ON to OFF, cutting off power to the motor and stopping it. In addition, if the front height and rear height switch is pushed to the DOWN side, operation is reversed with the motor revolving in the opposite direction and lowering the seat cushion.

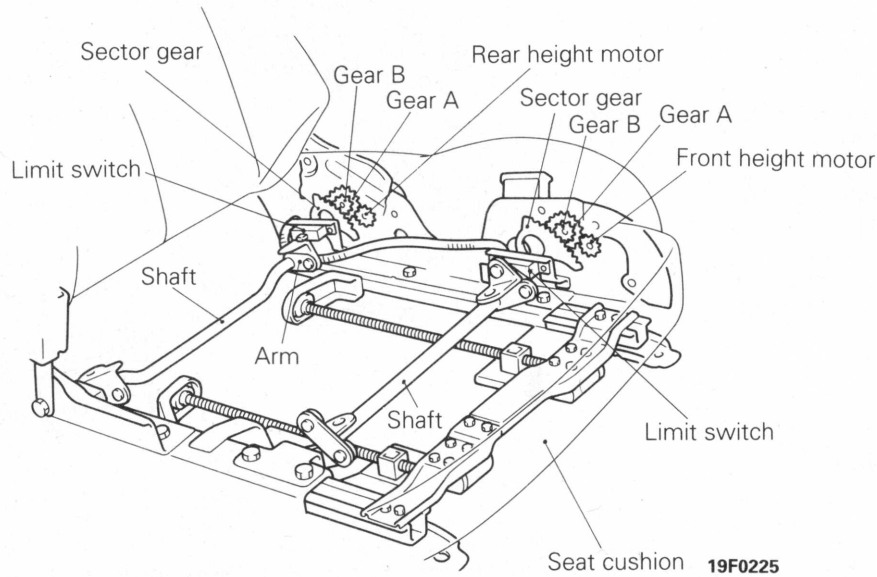

When raising front height



When raising rear height



When raising front and rear height



19F0049

<Raising>

Power seat switch B

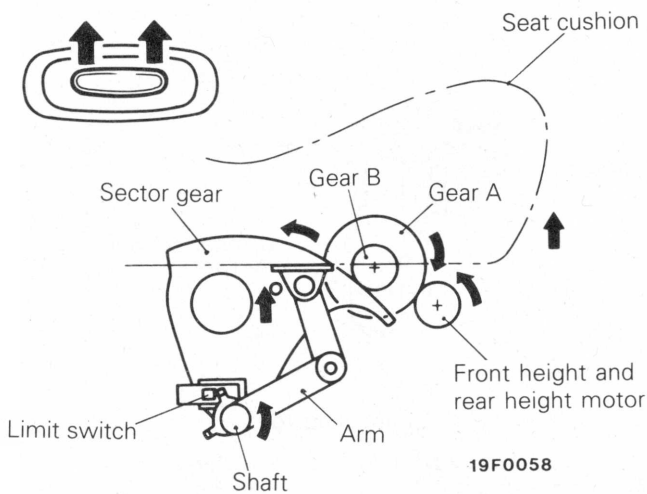

19F0058

<Lowering>

Power seat switch B

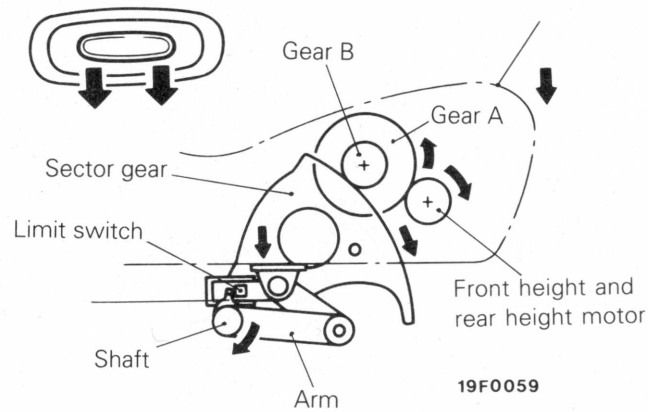

19F0059

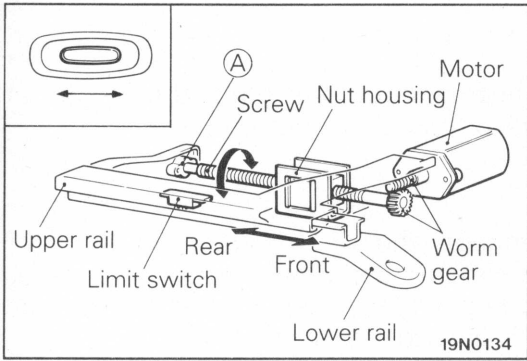

Slide Adjustment Structure

The motor and support **A** are fixed to the upper rail, and the nut housing is attached to the lower rail.

When the motor rotates, the worm gear drives the screw to shift the upper rail forward or backward. This controls the forward/backward seat sliding.

When the seat cushion reaches the forward or backwards limit, the upper rail pushes the limit switch on the lower rail to turn it OFF, and the motor stops.

RECLINING ADJUSTMENT MECHANISM WITH MEMORY

If the seatback is raised after being inclined to the front, it can be returned to the original angle set in memory by previously setting the seatback angle in memory.

Furthermore, even after it is reclined at any angle, if the seatback is raised after being inclined to the front, it can be returned to the original angle set in memory.

The construction and operation is the same as that for the '91 PAJERO.

HEADRESTRAINT (HORIZONTAL ADJUSTMENT MECHANISM)

There is a link mechanism in the headrest that can adjust the headrest in four steps forward and

backward without changing the angle at which the head touches its surface.

CONSTRUCTION

The stay and right/left bracket are one unit. The bracket and side frame are connected by right/left link B and link A and by the shaft. The shaft is one unit with the sector gear and right/left link A. There is a pawl on the left side frame and it is made to engage the sector gear by the

lock spring. The plate mounted on the shaft is pressed to pin A in the pawl by the spring and pin B in the sector gear is inserted in the oval hole.

OPERATION

When the headrest is pushed forward, link A and B rotate with support points A and B acting as the centre so the entire headrest moves forward. Since the sector gear rotates to the rear relative to the shaft in the centre, the engagement of the sector gear and pawl moves forward one tooth at a time and the headrest is fixed in each position. At this time, the plate is pushed forward by pin A.

ward. In addition, when it is pushed to the maximum forward position, pin A crosses over C in the plate and is caught in the catch. Then, the engagement of the sector gear and pawl is released and the headrest is returned to the maximum backward position by the force of the return spring. Since the oval hole hits pin B and the plate cannot move backward at a position just before the maximum backward position, pin A crosses over C. Then the pawl engages the sector gear, and the headrest is fixed in the maximum backward position.

When the headrest is pushed straight forward to the maximum forward position, the oval hole hits pin B in the sector gear and the plate cannot move for-

Maximum forward position

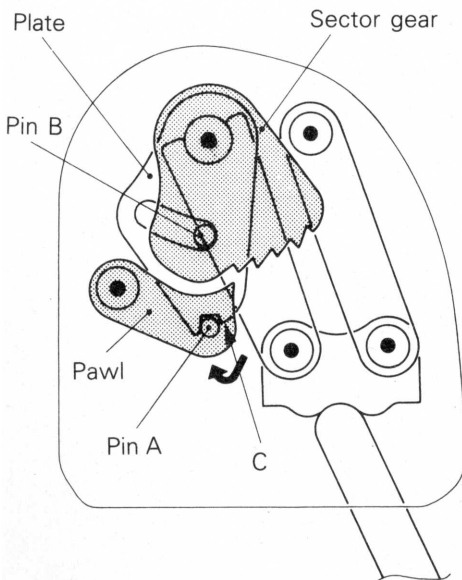

Maximum backward position

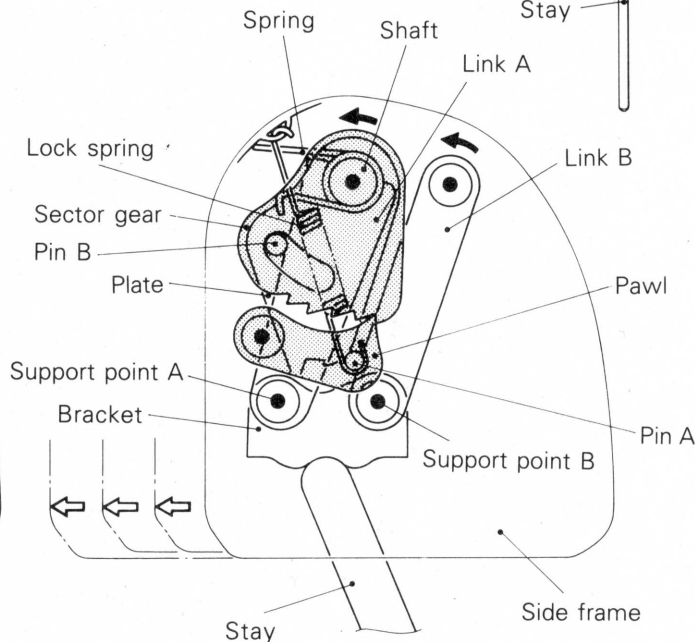

NOTE

- mark indicates centre of rotation of each part.

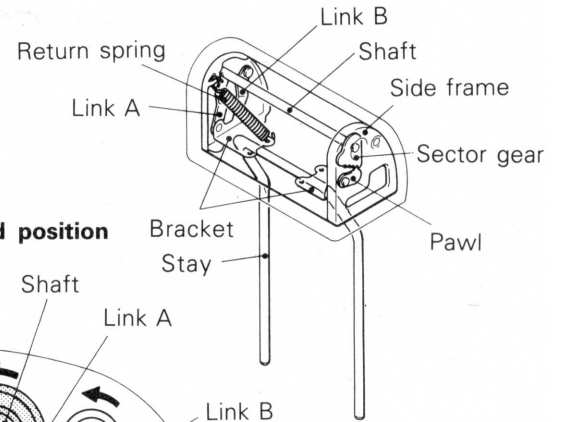

19N0052

19N0053

SEAT BELT

The seat belt has the following mechanisms.

FRONT SEAT BELT

- 3-point belt with ELR (electric type low tension seat belt) <Vehicles for General Export and GCC>
- 3-point belt with ELR <Vehicles for Europe and Australia>
- Buckle built in seat

REAR SEAT BELT

- 3- point belt with ELR

<Vehicles for Europe>

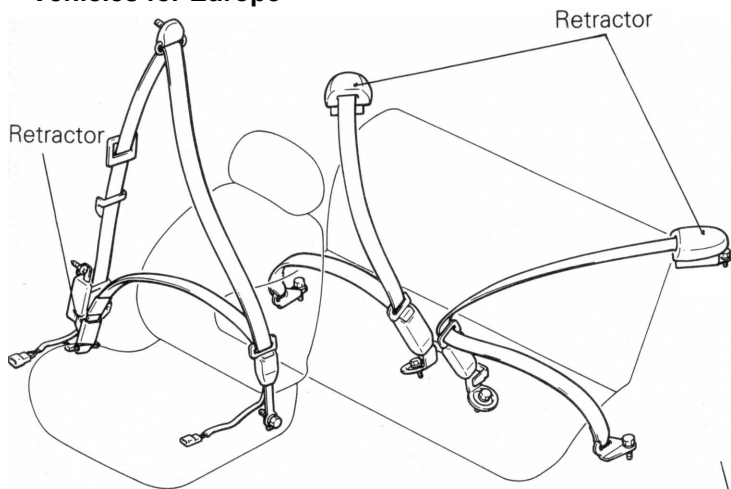

19F0219

<Vehicles for General Export, GCC and Australia>

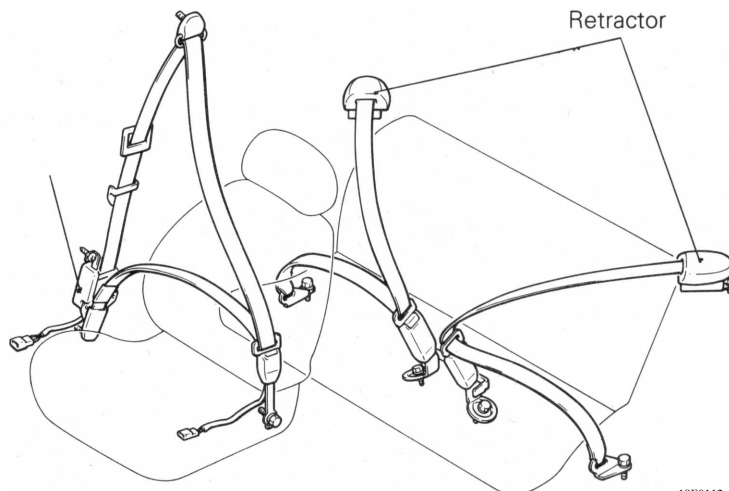

19F0112

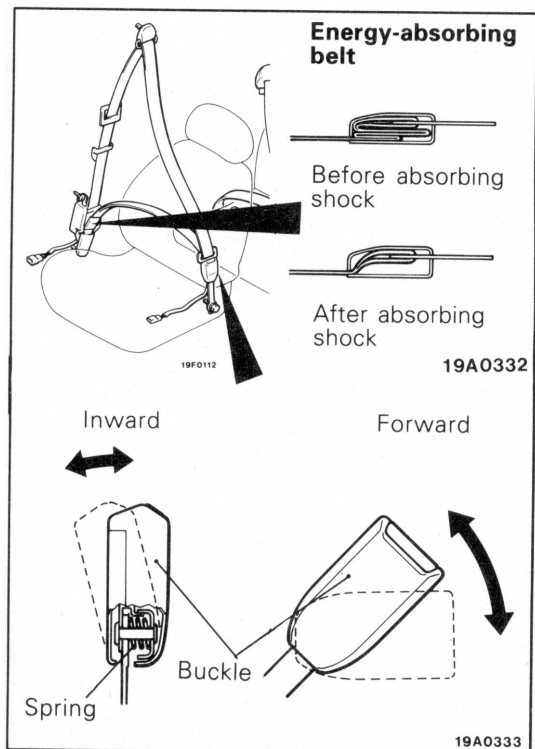

CONSTRUCTION AND OPERATION OF THE ENERGY-ABSORBING BELT AND THE BUCKLE

The front seat belt has on it a sleeve inside which the seat belt webbing is folded back over itself in a loop so as to absorb the energy of a shock by pulling loose and releasing slack. There is a spring installed in the portion connecting the buckle to the arm, allowing the buckle to tilt forward and inward so that the belts can be tight enough around the body.

**ELECTRIC TYPE LOW TENSION SEAT BELT
<Vehicles for General Export and GCC>**

There is an electric type low tension mechanism in the front seat belt retractor to reduce belt tension and the feeling of pressure when the seat belt is buckled. Furthermore, the tension reducer is maintained in an ON condition by the ETACS for 30 seconds after the ignition

key is turned OFF, and the belt winding force does not return to its original condition immediately after the ignition key is turned OFF so the passenger does not feel any physical disorder.

STRUCTURAL DESCRIPTION

The retractor shaft and bush shaft are coupled. The reducing spring and normal spring are springs used to wind the webbing. The reducing spring ends are fixed to the bush shaft and the spring case, and the normal spring ends are fixed to the tape holder and cover, and stored in the cover. There is a solenoid in the cover and when the seat belt is buckled, the solenoid is activated, the lever engages the tape holder, locks the normal

spring, thus lessening the feeling of constriction. The purpose of the memory tape is to eliminate the difference in elongation ratio of the reducing spring and normal spring. The ends are fixed respectively to the tape holder and bushing shaft and stored together with the bushing shaft in the tape holder in a wound up condition.

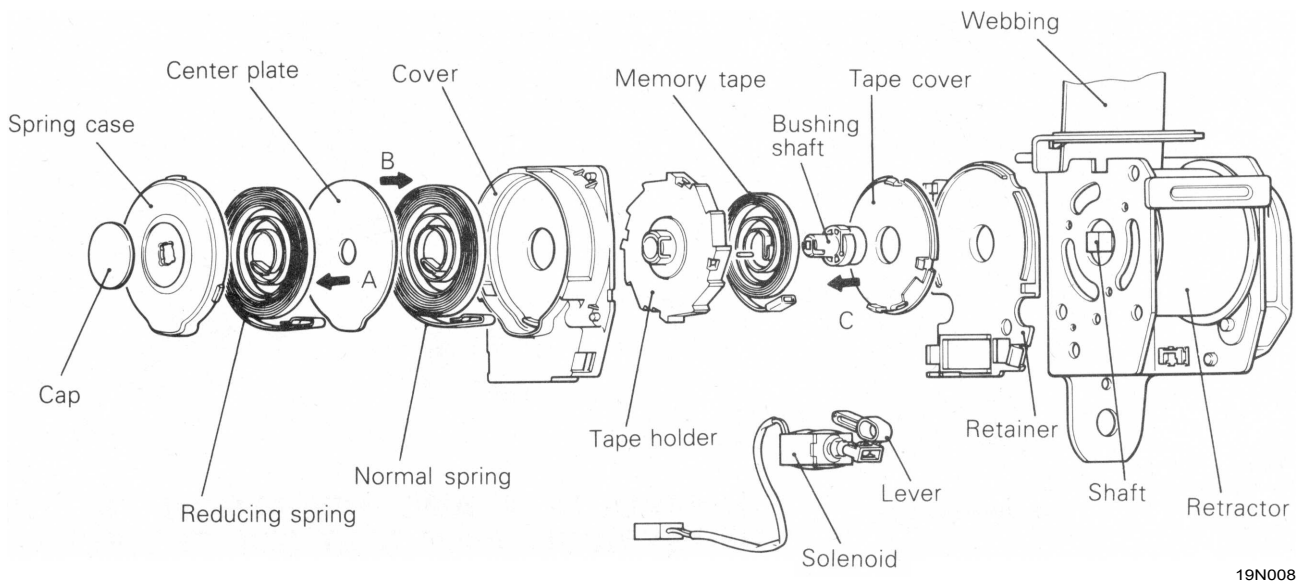

19N0080

View A

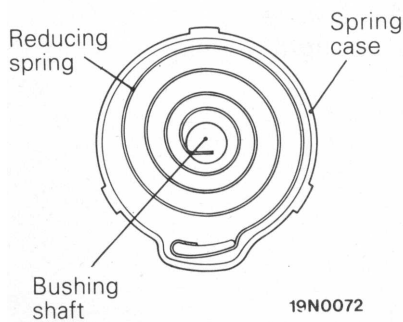

19N0072

View B

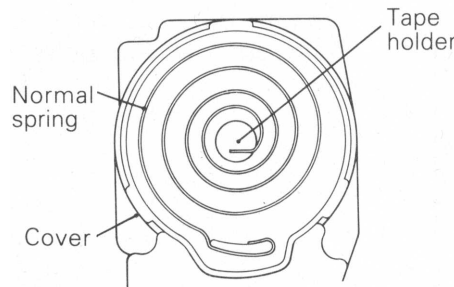

19N0073

View C

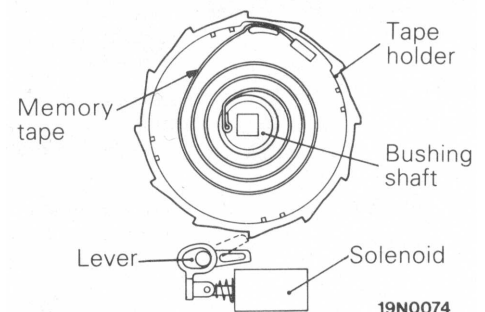

19N0074

OPERATIONAL DESCRIPTION

Seat Belt Stored Condition-7When Pulling Out

Since the memory tape is wound up, the bushing shaft and tape holder turn as one unit. The torque of the two springs, the reducing spring and normal

spring that are wound up, moves in the winding direction by the rotation of the bushing shaft and tape holder.

<When stored>

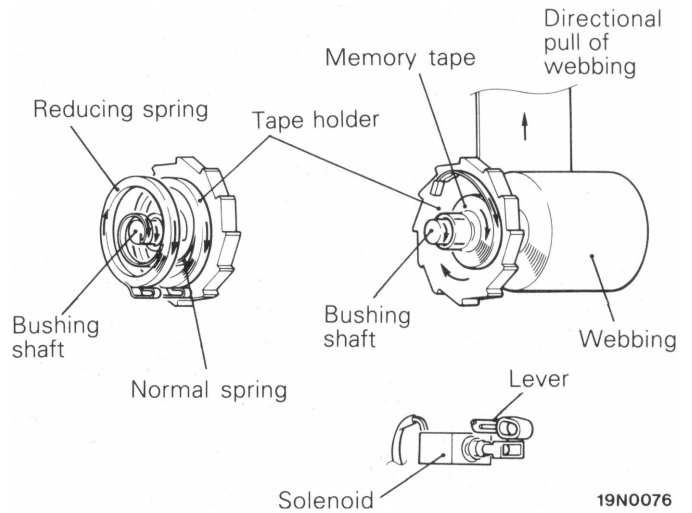
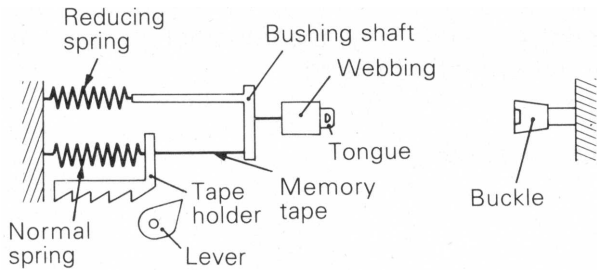

<When pulled out>

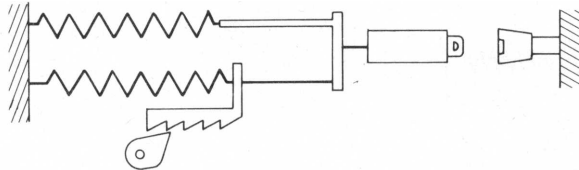

19N0077

19N0076

Buckle Switch ON → When Seat Belt is Initially Wound Up

When the webbing is pulled out and the tongue set in the buckle with the ignition switch in the ON position, the switch inside the buckle is turned ON, the solenoid functions and the lever meshes with the outer teeth of the tape holder. As a result, the tape holder is locked in the winding direction, torque of the normal spring falls to zero and the winding torque becomes only the torque of the reducing spring. Consequently, the feeling of oppression is reduced when the seat belt is initially buckled up and when it

remains buckles. Furthermore, since the tape holder is locked, the memory tape is loosened by the rotation of the bushing shaft in accordance with the winding of the reducing spring. The amount of loosening of the memory tape is the difference in the elongation ratio of the normal spring and reducing spring, and this serves to make the elongation ratio of the 2 springs the same when the seat belt is stored.

<When buckle switch is ON>

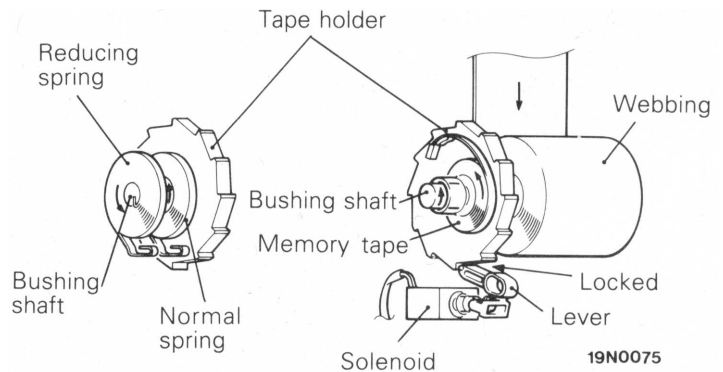
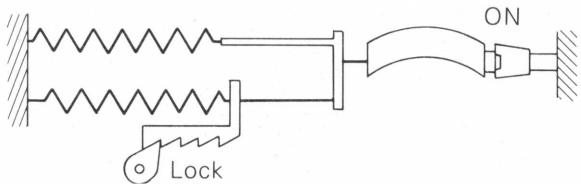

<When initially wound up>

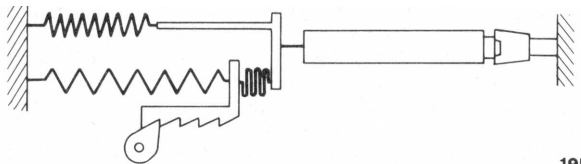

19N0078

19N0075

6-12

INTERIOR - Seat Belt

Buckle Switch ON → When Seat Belt is Initially Wound Up

When the tongue is released from the buckle with the ignition switch ON, the switch inside the buckle is turned OFF, current to the solenoid is cut off and the meshing of the lever and tape holder is released. As a result, the reducing spring begins winding. On the other hand, the normal spring turns the tape holder in the direction of winding and winds tight the

memory tape and, while the memory tape is loose, torque is not transferred to the bushing shaft. When the memory tape is wound completely tight, the elongation ratio of the normal spring and reducing spring is the same and the webbing is wound up by the torque of the 2 springs. In this way, the condition of the 2 springs is uniform when stored.

<When buckle switch is OFF>

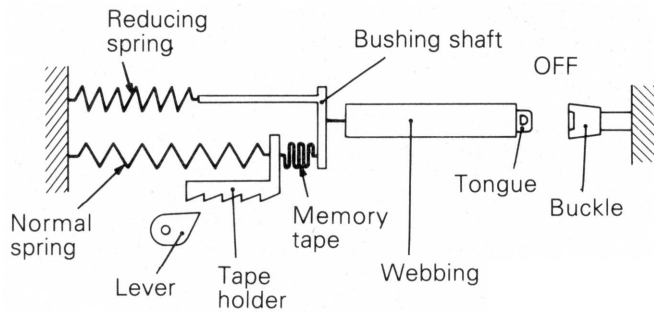

<When wound up>

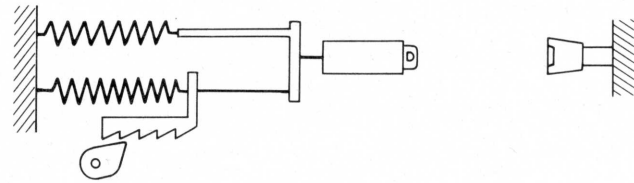

19N0079

SUPPLEMENTAL RESTRAINT SYSTEM (SRS)

The SRS is designed for use as a supplemental system for the seat belt, proving effective only when the seat belt is worn.

The SRS is provided for the driver's seat only.

The SRS consists of right and left front impact sensors, air bag module, SRS diagnosis unit (with built-in safing impact sensor), clock spring, SRS warning lamp knee protector, etc.

- Operates only when a front end collision applies an impact greater than a preset value to the whole vehicle, protecting the upper half of the driver's body.

- Has a double detection circuit to allow the air bag to deploy only when either of the right and left front impact sensors and safing impact sensor simultaneously enter the ON state, eliminating the possibility of accidental deployment.
- Has an SRS diagnosis unit in which the backup function (charge capacitor for the power supply) against a power failure that may occur when the bag is to deploy (at the time of an impact) and the voltage boosting function (D.C. - D.C. converter circuit) against a low voltage battery are accommodated.
- Has a self-diagnostic function for higher safety and reliability.

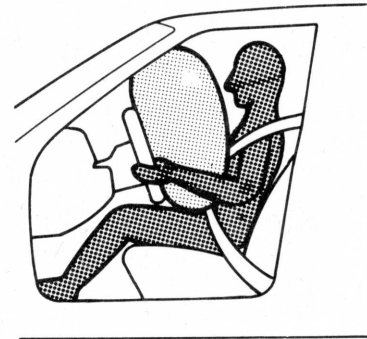
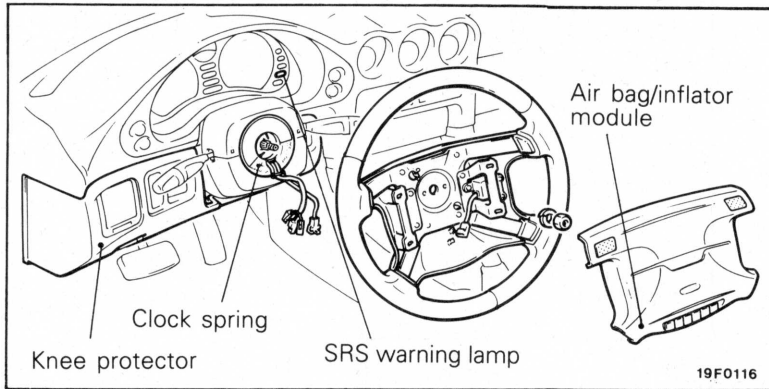

13R0707

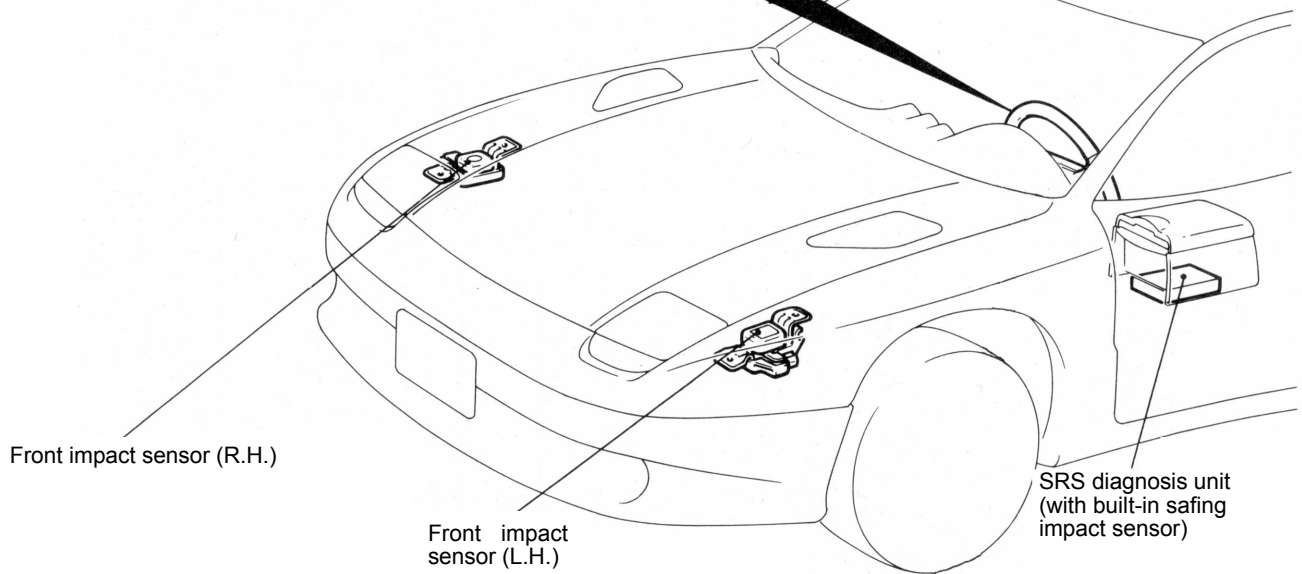

19F0115

SRS SCHEMATIC

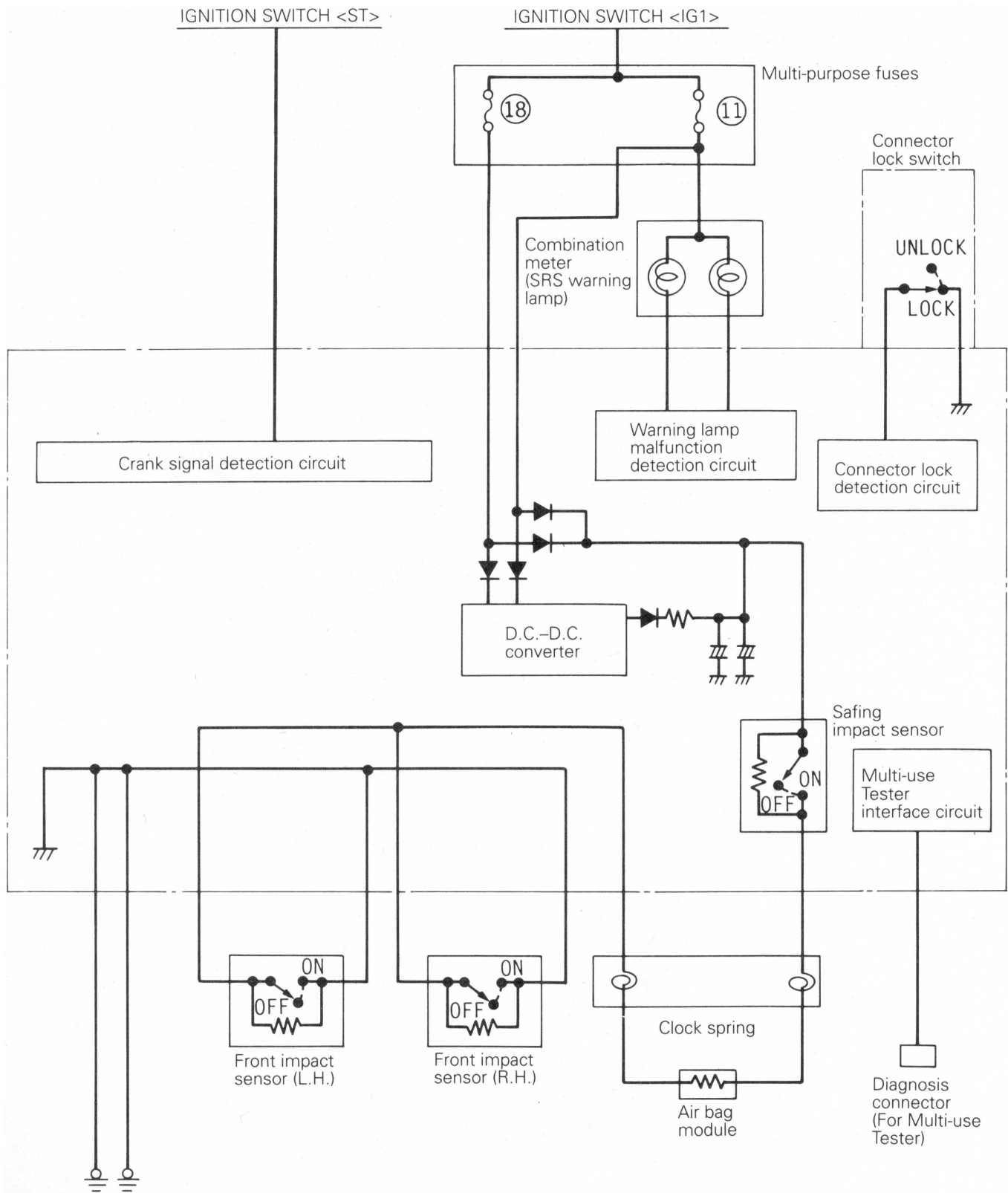

WARNING/CAUTION LABELS

A number of caution labels relating to the SRS can be found in the vehicle, as shown in the following illustration. Follow label instructions when servicing SRS.

The language written in the label is principally English, but some of the labels are written in German or French.

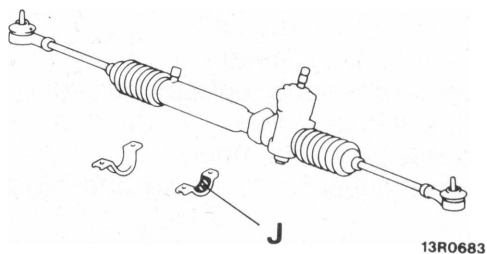
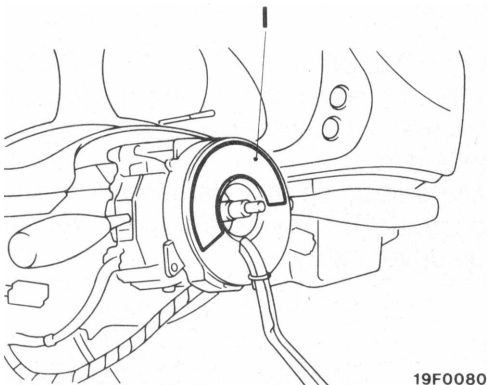
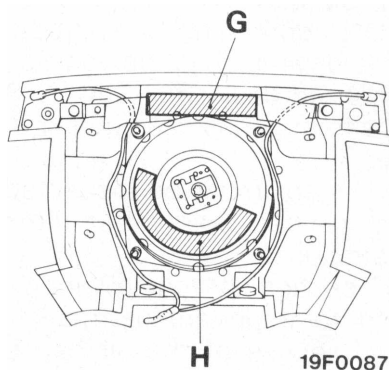
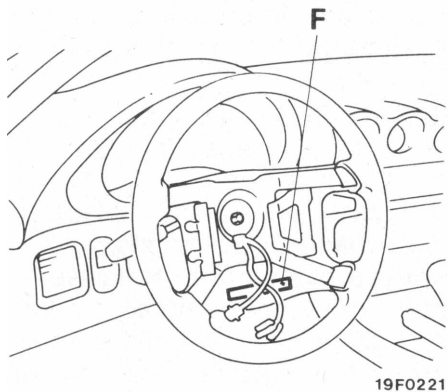
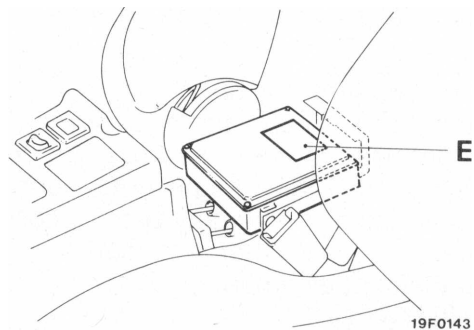
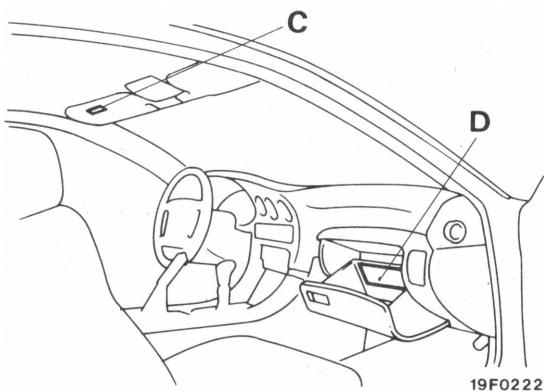
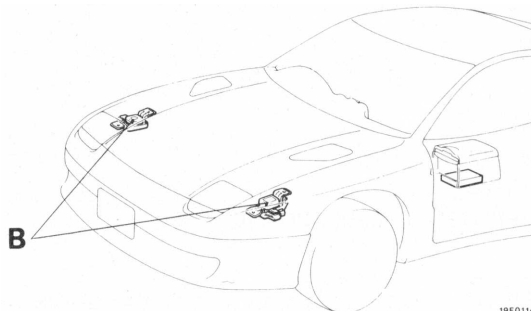
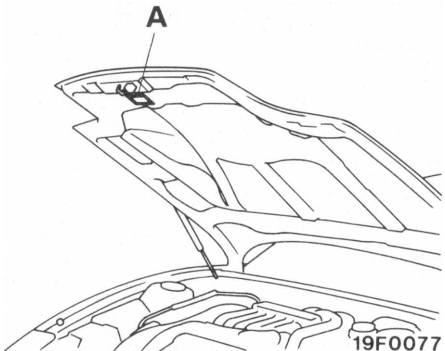

6-16

INTERIOR - Supplemental Restraint System (SRS)

- A. **WARNING**
This vehicle has a supplemental driver's side air bag.
Refer to service manual before servicing or disassembling underhood components. Read "SRS" section of manual for important instructions. Improper service procedures can result in the air bag firing or becoming inoperative, leading to injury.
- B. **CAUTION: SRS**
Read service manual.
Do not drop.
Do not tamper or disassemble.
- C. This vehicle has a driver's side air bag to supplement the driver's seatbelt in certain frontal collisions.
The driver and all other occupants must wear seatbelts at all times to reduce possible injury.
- D. **Driver's air bag information**
This vehicle has an air bag which will supplement the driver's seatbelt in certain frontal collisions. The air bag is not a substitute for the driver's seatbelt in any type of collision. The driver, and all other occupants, should wear seatbelts at all times.
WARNING!
If the "SRS" warning light does not come on for about 7 seconds when ignition key is turned to "ON" or engine is started, or if it stays on while driving, drive the vehicle to your nearest authorized dealer right away. Also do so if vehicle's front end is damaged or if air bag has deployed.
The air bag system must be inspected by an authorized dealer ten years after the date of vehicle registration.
Read "SRS" section of your owner's manual before driving, for important information, about operation and service of the air bag system. When you are going to scrap your gas generator or vehicle, please see your MITSUBISHI dealer.
- E. **CAUTION: SRS diagnosis unit**
This unit cannot be repaired.
If defective, remove and replace entire unit per service manual instructions.
Do not disassemble or tamper.
See service manual for handling and storage instructions.
Do no drop: keep dry.
Failure to follow instructions could render air bag inoperative and result in driver injury.
- F. **CAUTION: SRS**
Before replacing steering wheel, read service manual, centre front wheels and align SRS clock spring neutral marks.
Failure to do so may render SRS system inoperative, risking serious driver injury.
- G. **CAUTION: SRS clock spring**
This is not a repairable part. Do not disassemble or tamper.
If defective, remove and replace entire unit per service manual instructions.
Before replacement, read service manual, .centre front wheels and align neutral marks. Failure to follow instructions may render SRS system inoperative, risking serious driver injury.
- H. **Danger! Poison. Keep out of the reach of children.**
Contains sodium azide and potassium nitrate contents are poisonous and extremely flammable. Contact with acid, water, or heavy metals may produce harmful and irritating gases or explosive compounds. Do not dismantle, incinerate, bring into contact with electricity or store at temperatures exceeding (93°C) 200°F.
First aid: If contents are swallowed induce vomiting. For eye contact flush eye with water for 15 minutes. If gases from acid or water contact are inhaled, seek fresh air. In every case, get prompt medical attention.
For additional information; see material safety data sheet (MSDS) for this product.
- I. **CAUTION: SRS clock spring**
This is not a repairable part. Do not disassemble or tamper.
If defective, remove and replace entire unit per service manual instructions.
Before replacement, read service manual, center front wheels and align neutral marks. Failure to follow instructions may render SRS system inoperative, risking serious driver Injury.
- J. **CAUTION: SRS**
Before removal of steering gearbox, read service manual, centre front, wheels and remove ignition key.
Failure to do so may damage SRS clock spring and render SRS system inoperative, risking serious driver injury.

CONSTRUCTION AND OPERATION

IMPACT SENSORS

There are 2 different types of sensors used; 2 front impact sensors and safing impact sensor. One front impact sensor is provided in each of the right and left lower side members, and one safing impact sensor is built in the SRS diagnosis unit. The right and left front impact sensors are connected in parallel.

The front impact sensors are connected in series with the safing impact sensor. If a front-end collision causes either of the front impact sensors and the safing impact sensor to be simultaneously "ON", the air bag will deploy.

The front and safing impact sensors are essentially identical in construction.

They are constructed as shown below and contain a G sensor each.

The G sensor consists of a moving contact which is a roll spring wound around a roller, a fixed contact positioned in its moving direction, consisting of a base,

a metallic case, etc. If an impact greater than preset is applied in the direction of the arrow shown in the illustration, the inertial force causes the roller to rotate and move, so that contacts are brought into the ON state. To maintain a high measure of G sensor reliability, the contacts have been gold plated and the metallic case charged with an inactive gas.

Each impact sensor contains a resistor connected in parallel with the contacts for detection of a fault in the wiring. The SRS diagnosis unit always supplies a very small amount of current to the sensor circuit to monitor a change in the circuit resistance.

Caution

Make sure that the impact sensors are never disassembled.

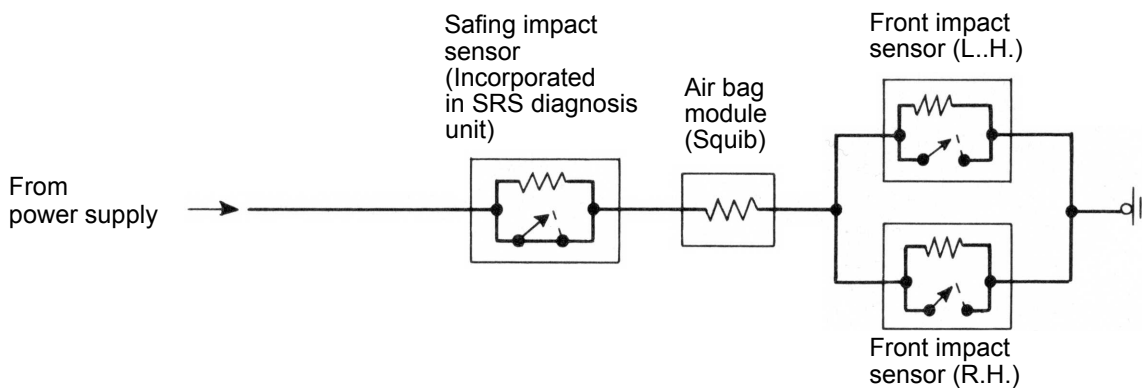

13R0724

Front impact sensor

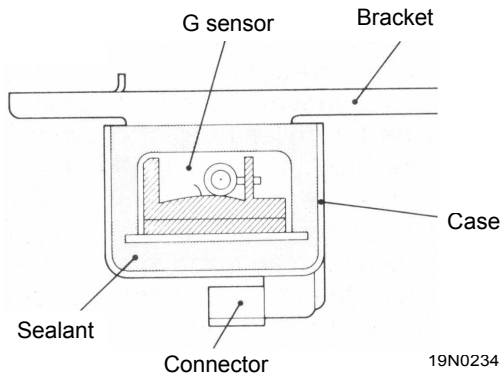

Safing impact sensor

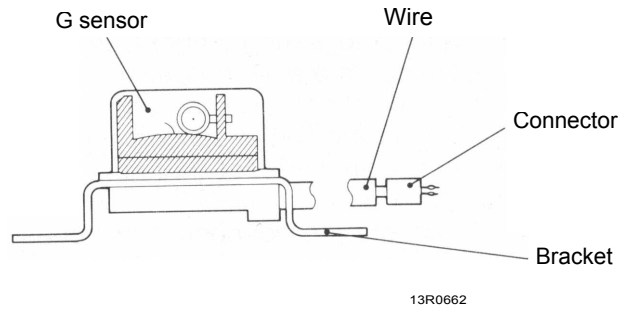

G sensor

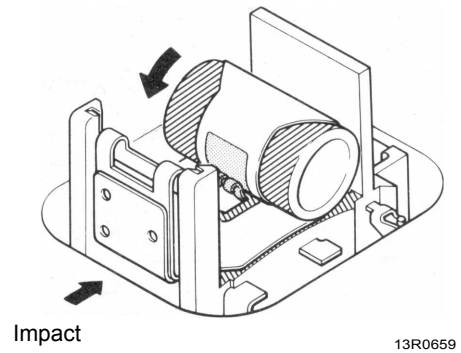
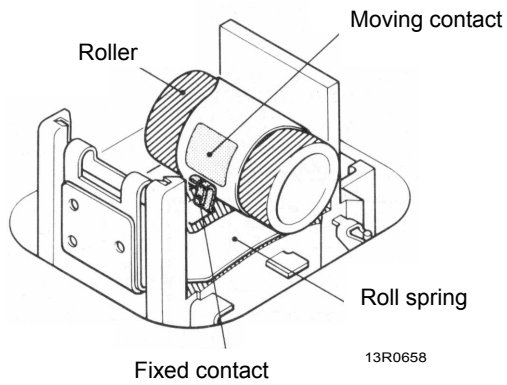
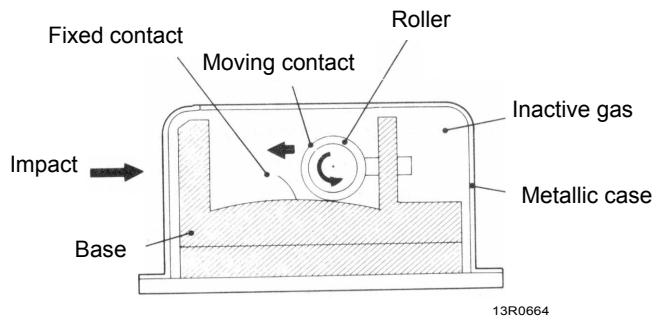

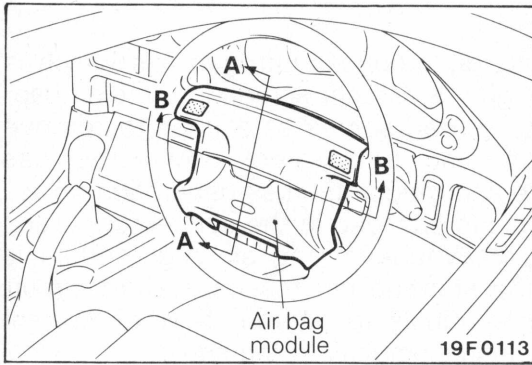

AIR BAG MODULE

The air bag module is an assembly part comprising of an air bag, pad cover, inflator, and parts for securing them. It is provided at the centre of the steering wheel.

Caution

Make sure that the air bag is never disassembled.

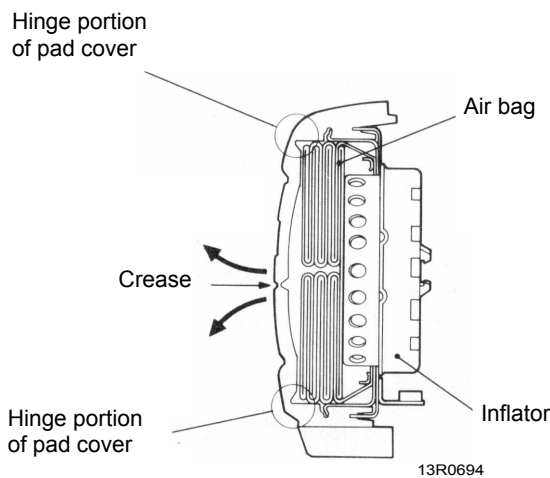

Section A - A

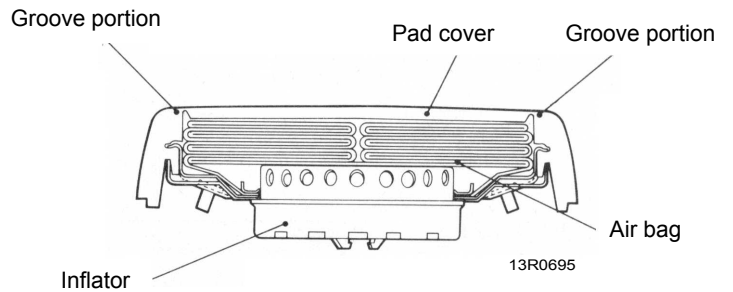

Section B - B

← : Pad cover deploying direction

Air bag

The air bag is made of a nylon cloth with a rubber coating inside. It is accommodated in the pad at the centre of the steering wheel together with the inflator. The air bag is inflated by the nitrogen gas from the inflator. The load of the driver pressed against the air

bag by the impact causes the nitrogen gas to escape through the two exhaust holes made on the rear, and the deflation helps lessen the impact.

Pad cover

The pad cover is made from urethane. When the air bag deploys, the crease is broken, allowing the air bag to move out and deploy with the hinge portions as its fulcrums. The pad cover has a net, etc. insert-molded

except for the crease to prevent the air bag from being broken as it deploys, and also to prevent broken pieces from scattering around.

Inflator

The inflator consists of a squib, igniter, gas generants, diffuser screen, etc. contained in an aluminum container. It is mounted in the air bag module housing.

The bottom of the inflator is provided with an electrical connection to which an ignition current is supplied. If current is supplied to the squib, a small amount of explosive in the squib is burnt causing the igniter to burn, and the resultant heat burns the gas generants. Combustion of the generants rapidly produces nitrogen

gas which is forced through the diffuser screen into the air bag. The diffuser screen serves as a filter to remove cinders and also helps cool down the gas temperature and reduce the gas generation noise. A shorting pin is provided in the connector portion of the squib. Whenever the air bag module is removed, the shorting pin makes a short circuit across the terminals to prevent flow of current caused by static electricity to the squib.

NOTE

The cross sectional view of the inflator was plotted on the basis of a sketch prepared by Moton Thiokol

Automotive Products Division.

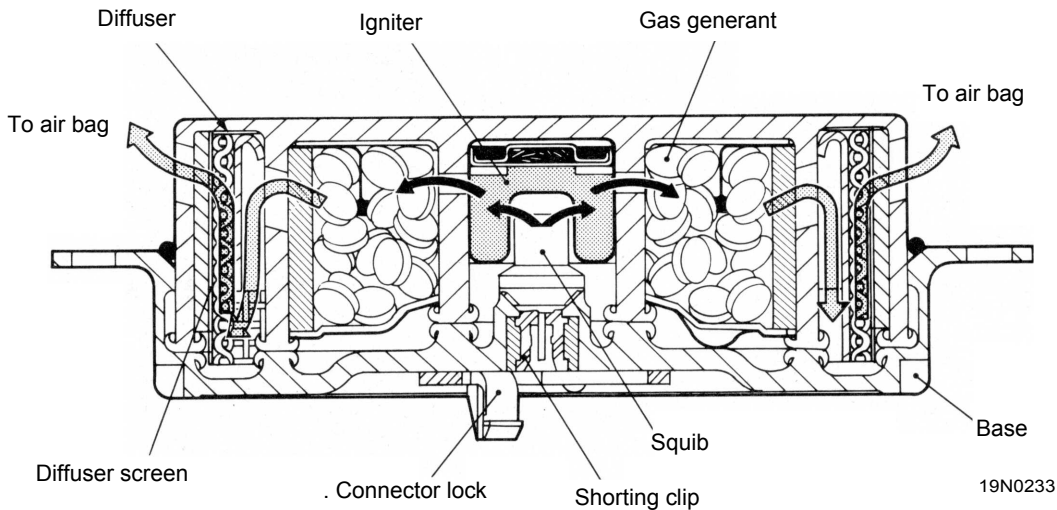

⇐ : Nitrogen gas
 ⇐ : Flame

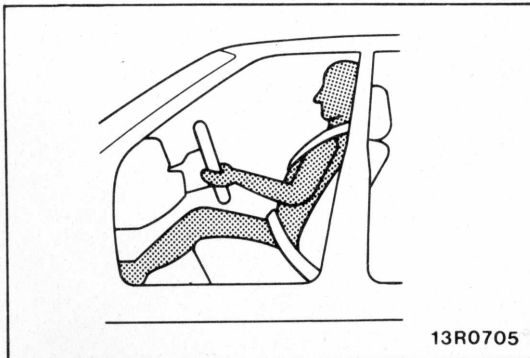

**Air bag deployment operation
 (in case of 50 km/h (30 mph) frontal impact)**

**(1) OPERATION FOR APPROXIMATELY 15 MILLISECONDS
 AFTER THE COLLISION**

If a strong impact produced by a collision is detected by either of the front impact sensors and the safing impact sensor in approximately 10 milliseconds after the collision, the SRS diagnosis unit will supply an ignition signal to the squib.

In approximately 3 milliseconds after the ignition signal has been supplied to the squib, gas generation will begin.

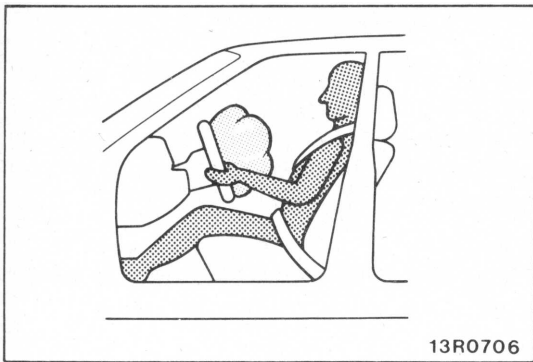

- (2) In approximately 20 milliseconds after the collision, the air bag folded in the pad cover will begin to inflate, the pad cover will break at its crease, and the air bag will expand outward.

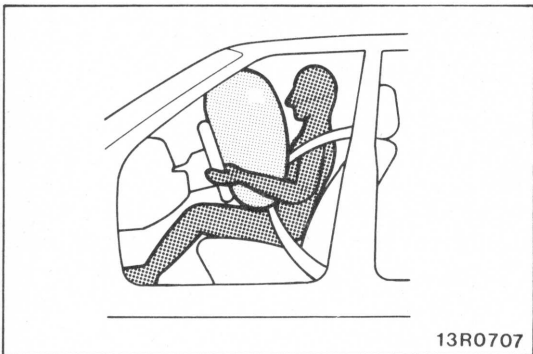

- (3) In approximately 35 milliseconds after the collision, the inflated air bag will touch the chest of the driver.

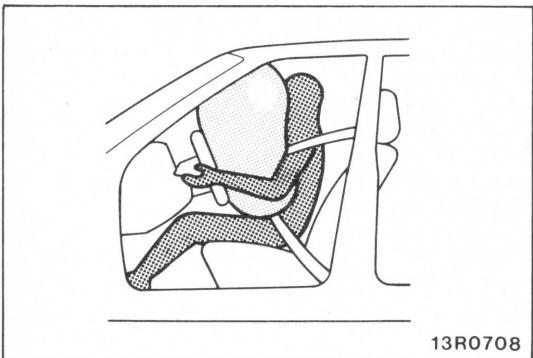

- (4) In approximately 40 milliseconds after the collision, the air bag will be fully inflated.

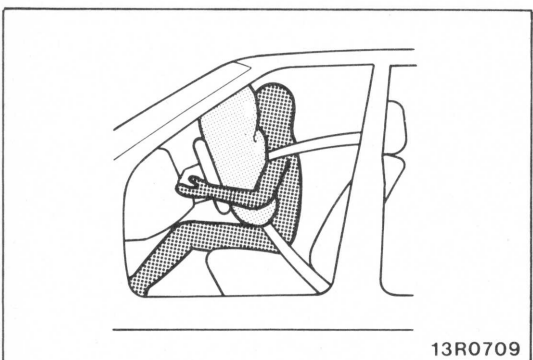

- (5) In approximately 55 milliseconds after the collision, the pressure of the driver against the air bag causes the gas to escape through the two exhaust holes on the rear of the module, and the deflation helps lessen the impact imposed on the driver.

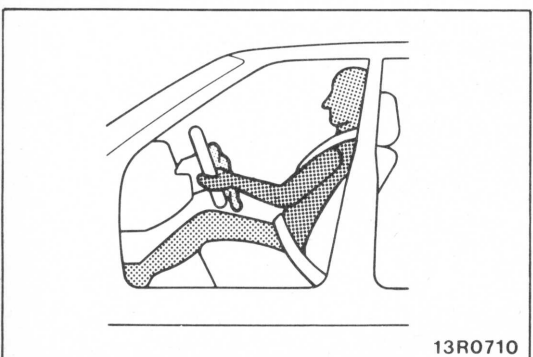

- (6) In approximately 105 milliseconds after the collision, the air bag that has absorbed the impact will rapidly deflate, providing visibility for the driver.

SRS DIAGNOSIS UNIT

The SRS diagnosis unit monitors the impact sensors, squib, wiring harness, condensers, battery voltage etc. It detects a problem, it and illuminates the "SRS" warning lamp to alert the driver. It also stores in memory what the problem is, and the duration of the problem (the duration during which the warning lamp kept ON). The condensers provided in the diagnosis unit accumulates electric energy during the period the

ignition switch is ON to supply the squib ignition current, even if the power cable from the battery is broken by the collision, to inflate the air bag as soon as the front impact sensor and safing impact sensor are simultaneously switched ON.

Caution

Make sure that the SRS diagnosis unit is never disassembled.

1. Monitoring function

The SRS diagnosis unit monitors the items of the wiring harness and SRS components shown in the following table to check whether they satisfy the specified values. When the ignition key is in "ON" or "START" position, the SRS warning lamp should illuminate for about 7 seconds and then turn off.

This indicates that the SRS system is in operational order. If the SRS warning lamp does any of the following, immediate inspection is needed.

- (1) The SRS warning lamp does not illuminate as described above.
- (2) The SRS warning lamp stays on for more than 7 seconds.
- (3) The SRS warning lamp illuminates while driving.

The data of the fault is stored in terms of a diagnosis code in the non-volatile memory (EEPROM) *. The duration of the fault is also stored in terms of the ON duration of the warning light.

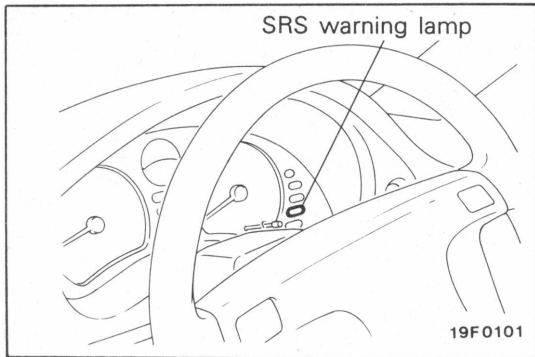

Component	Main Monitoring Point	Diagnosis Code No.
Front impact sensor	Short-circuit	11
	Open-circuit once	12
	Open-circuit twice	13
Squib	Short-circuit	21
	Open-circuit	22
Condenser	Terminal voltage high	31
	Terminal voltage low	32
Cranking detection circuit	Cranking signal detection time	33* ¹

Component	Main Monitoring Point	Diagnosis Code No.
Double lock connector	Unlock or lock switch open-circuited	34* ¹
Battery	IG1 voltage low (Multi-purpose fuse No. 11 is blown)	41* ¹
	IG 1 voltage low (Multi-purpose fuse No. 18 is blown)	42* ¹
SRS warning lamp	External circuit open-circuited or short-circuited	43* ¹
	Drive circuit defective	44
Diagnosis unit	EEPROM defective	45
	A/C converter defective	

NOTE

* EEPROM = Electrically Erasable Programmable ROM

A ROM to which data can be stored and be electrically written and from which data can be electrically erased.

*1: Equipped with the automatic diagnosis code erasure function. (Refer to P.6-25)

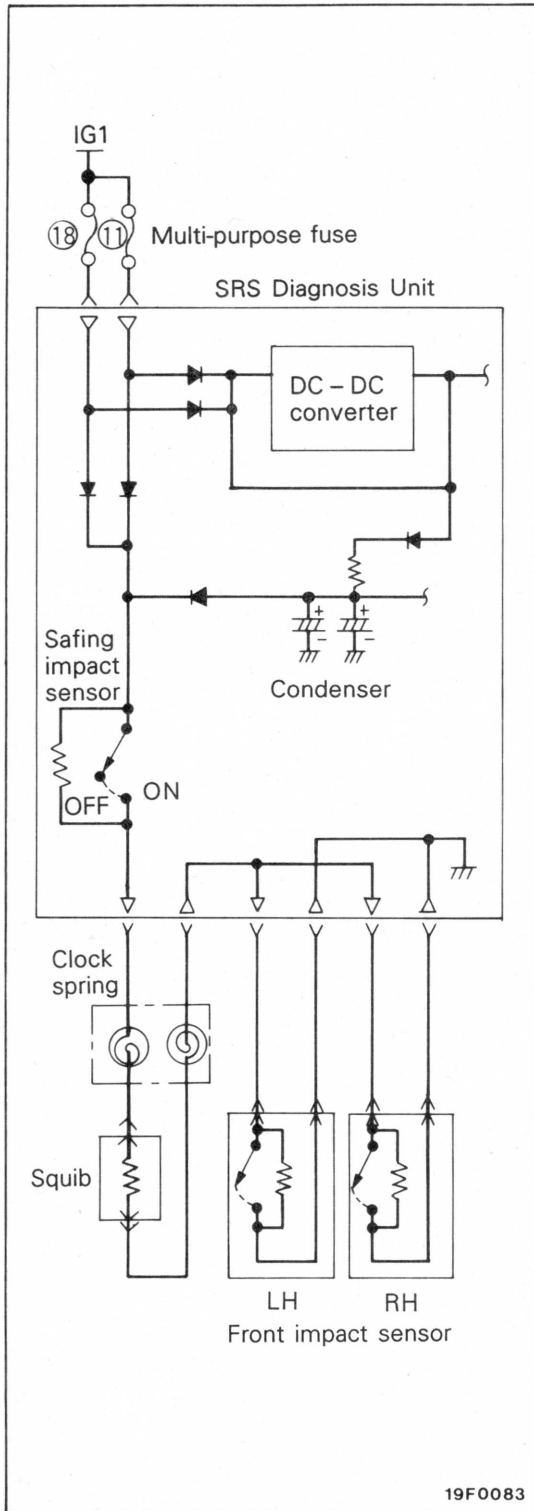

2. Supplying squib ignition energy

The energy for ignition of the squib is supplied by two circuits; the battery of the vehicle and the condensers. Even if the power voltage of the SRS diagnosis unit is lost, the ignition capability is retained by the condensers for more than 0.5 seconds.

- (1) The two independent battery power supplies (from fuses 11 and 18) are connected via diodes in the diagnosis unit. If the voltage is larger than 9V between the connector terminal of the unit and the ground, the squib can be ignited.
- (2) The IG 1 voltage is boosted to about 25V by the DC-DC converter to provide more in reserve than the low limit voltage mentioned above in charging the condensers that supply the ignition energy.

Caution

1. When the SRS is to be repaired or parts to be replaced, make sure that the negative (-) cable of the battery is disconnected beforehand for insulation. After the negative (-) cable of the battery has been disconnected, wait for more than 60 seconds before making any service attempt.

The condensers in the SRS diagnosis unit retains for a given period the voltage necessary for inflating the air bag even after removal of the battery voltage.

If a service attempt is made during the period, accidental inflation could cause serious personal injury.

2. Do not measure the resistance across the terminals of the SRS diagnosis unit. Do not directly touch the test probe to any of the terminals.

Even if an attempt is made to measure the resistance, no correct value can be obtained because of the effects of internal circuits. In addition, there is a danger of damage to the gold plated portion of the terminals.

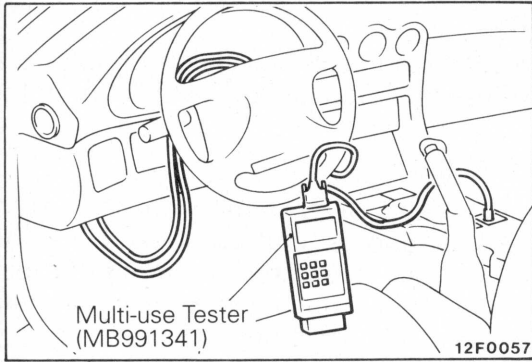

3. **Diagnosis function**

Fault diagnosis continues to be performed during the period the ignition switch is ON except during cranking. If a fault is detected, the SRS warning lamp is lit.

The microcomputer determines a diagnosis code on the basis of the results of measurements by various measuring circuits and stores it in "EEPROM".

The fault duration (the period the warning lamp has been ON) is integrated in increments of a minute and stored in the EEPROM together with the diagnosis code. The stored data can be read and erased by a Multi-use tester. The number of times the memory has been erased by a Multi-use tester is stored in the "EEPROM" to provide reference information on the past service history. The data can be read by a Multi-use tester in the same way as the fault durations.

Data to be stored	Description
Faults	All faults stored in diagnosis codes
Fault duration	The period the warning lamp is ON is integrated in minutes. (Maximum stored period: 9999 minutes ≈ 7 days)
Number of times memory can be erased	The number of times the diagnosis codes and fault durations have been erased by a Multi-use tester is integrated. (Maximum number of times to be stored: 250)

NOTE

Once a fault is detected, the SRS warning lamp continues to lamp, even if normal operation of the system is restored, until the diagnosis code is erased.

4. **Automatic diagnosis code erasure function**

The Automatic diagnosis code erasure function operates according to the indicated diagnosis code No. (Refer to P.6-23). Once the malfunction location that causes a diagnosis code to be displayed returns to the normal condition, if the malfunction reoccurs continuously at 5-second intervals, the appropriate malfunction code can be erased. At this time, if all other diagnosis codes have been erased, the SRS warning lamp will switch off and the intermittent durations of the malfunction will also be erased automatically. In this case, the erasure is not included in the number of times erased.

NOTE

If the AID converter inside the SRS diagnosis unit is malfunctioning, diagnosis codes No. 41, 42 and 43 will not be erased by the automatic diagnosis code erasure function. Furthermore, during cranking, none of the codes will be erased by this function.

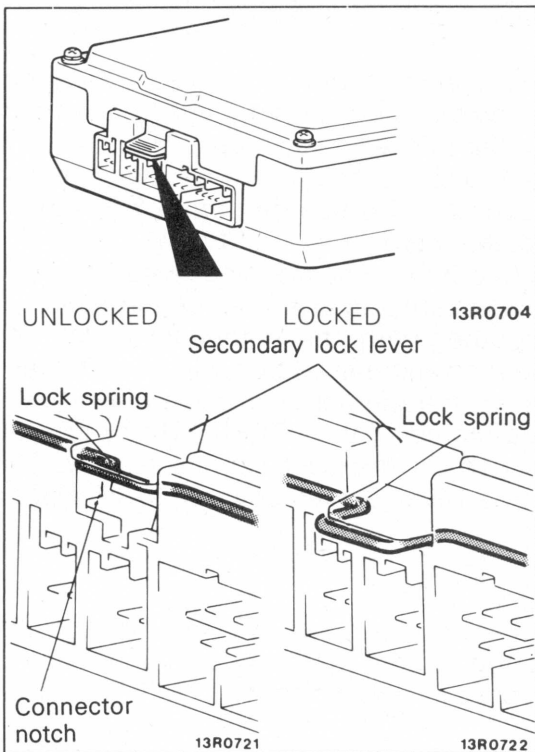

SRS CONNECTOR

The connector of the SRS diagnosis unit has a double lock mechanism, fit verification mechanism and connector shorting mechanism.

DOUBLE LOCK MECHANISM

The mechanism is composed of two mechanisms: each connector of the SRS diagnosis unit is locked to the connector of the harness, then these connectors (of the four harnesses) are locked with the secondary lock lever mounted on the connector of the SRS diagnosis unit side.

The secondary lock lever locking is done as the lock spring fits in the notch of the connector.

The operating principle is described below.

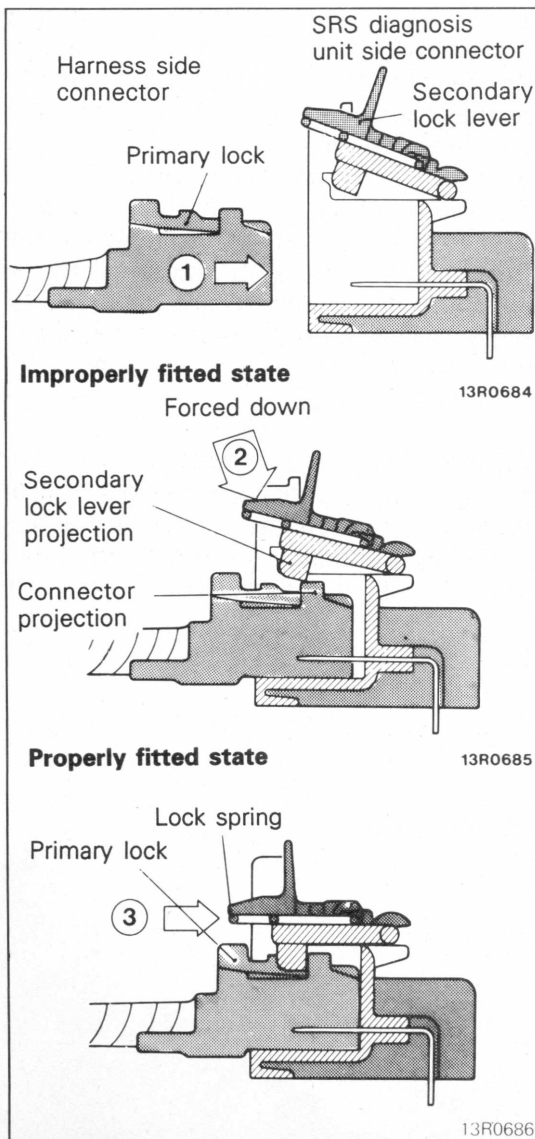

When Connectors Are To Be Fitted

- (1) The SRS diagnosis unit and harness side connectors are fitted. (Primary lock)
- (2) The secondary lock lever mounted to the SRS diagnosis unit side connector is pressed down by finger until a click is heard indicating that the connectors have been locked. (Secondary lock)

If the harness and SRS diagnosis unit connectors do not properly fit, the secondary lock lever side projection and the harness side connector projection interfere with each other, making it impossible to lock the connectors.

When Connectors Are Unlocked

- (1) Press in the lock spring with a flat tip (-) screwdriver to disengage the lock spring from the notch area of the connector, and release the lock (secondary lock) of the secondary lock lever.

Caution

Forced removal of the connector without releasing the secondary lock lever will result in a damaged lock lever.

- (2) Press the primary lock of each of the harness side connectors and remove the harness side connector.

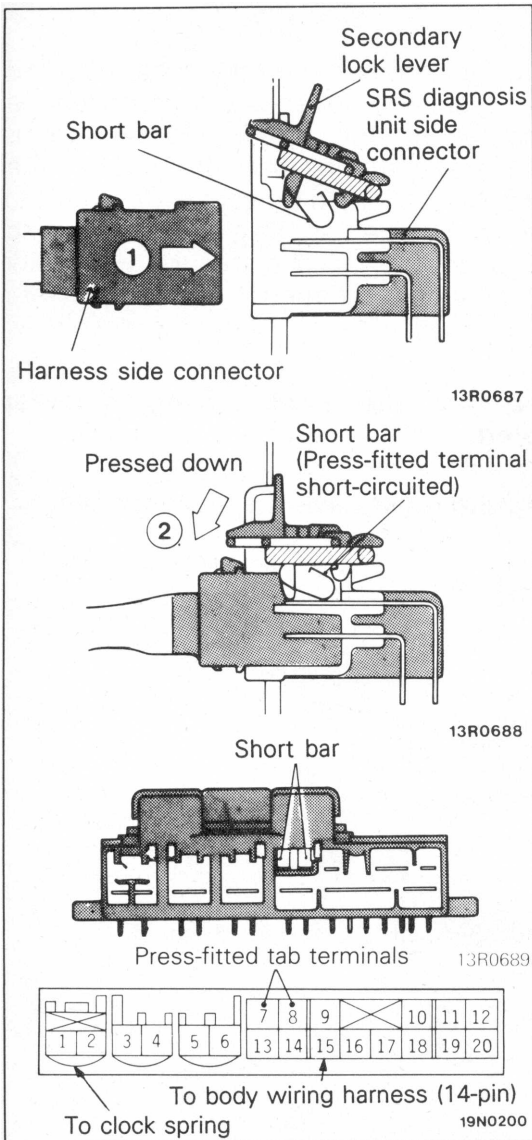

FIT VERIFICATION MECHANISM

The mechanism is used to electrically check the engagement of the connector between the SRS diagnosis unit and the body wiring harness. The operating principle is described below.

- (1) Securely connect the SRS diagnosis unit and harness side connectors and press the secondary lock lever down to lock the connectors.
- (2) At this time, the short bar provided on the rear surface of the secondary lock lever produces a short circuit across terminals No. 7 and 8 of the SRS diagnosis unit. The SRS diagnosis unit supplies monitoring current to the circuit to electrically verify that the connectors have been locked.

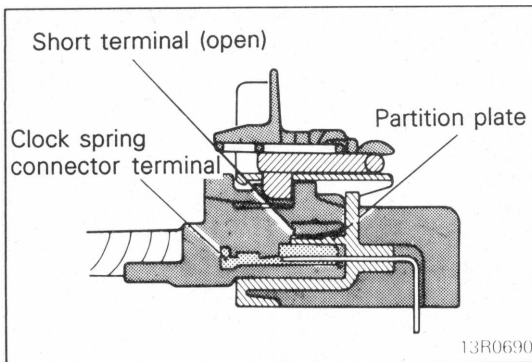

CONNECTOR SHORTING MECHANISM

The mechanism is designed for prevention of accidental explosion of the inflator when the clock spring connector (for the squib circuit) is removed from the SRS diagnosis unit. The operating principle is described below.

When Connectors Are Fitted

When the SRS diagnosis unit and clock spring connector are coupled, the circuit between the short terminals and clock spring connector terminals are kept in the OFF state by the partition plate provided in the connector of the SRS diagnosis unit.

When Connectors Are Disconnected

When the clock spring connectors are disconnected from the SRS diagnosis unit, the partition plate between the short terminals and clock spring connector terminals is removed. As a result, a short circuit is formed between the two poles of the clock spring connector terminals to prevent generation of a potential difference (current) between the squib terminals.

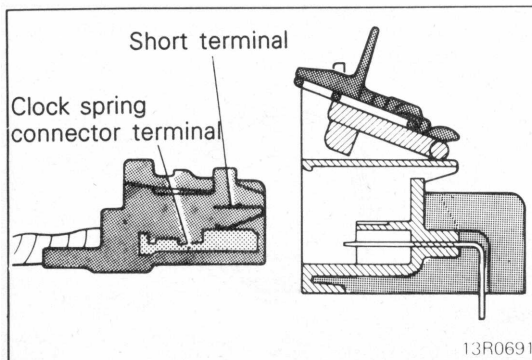

CLOCK SPRING

The clock spring is provided between the steering wheel (air bag module) and column switch body (steering column).

The clock spring provides harness connections, not contact connections like horn contact as in the past, between the air bag module and SRS diagnosis unit, between the horn switch and body wiring harness, and between the remote control switch and body wiring harness.

The clock spring consists of a neutral position indication mechanism, flat cable, upper case, lower case, rotor, etc.

The flat cable loosely wound like a coil is held in the upper and lower cases with one of its ends mounted to

the rotor and the other end mounted to the upper case. The upper and lower cases are mounted to the steering column. The rotor is coupled with the steering shaft. Rotation of the steering wheel (steering shaft) causes the rotor to rotate. Accordingly, the flat cable is wound round the rotor or loosened, and operates with the rotor as the steering wheel is turned.

Caution
Make sure that the clock spring is never disassembled.

Caution
The clock spring must never be disassembled.

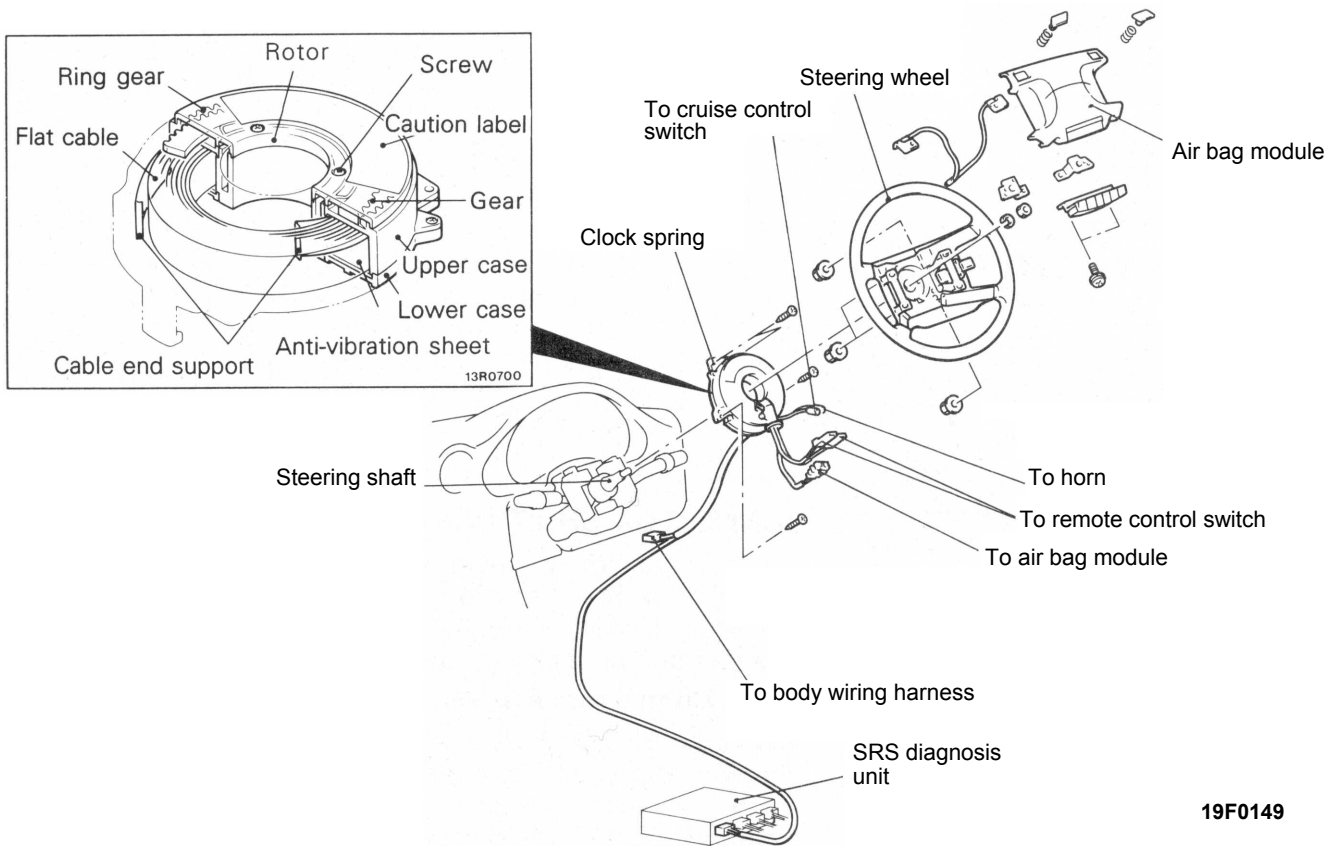

19F0149

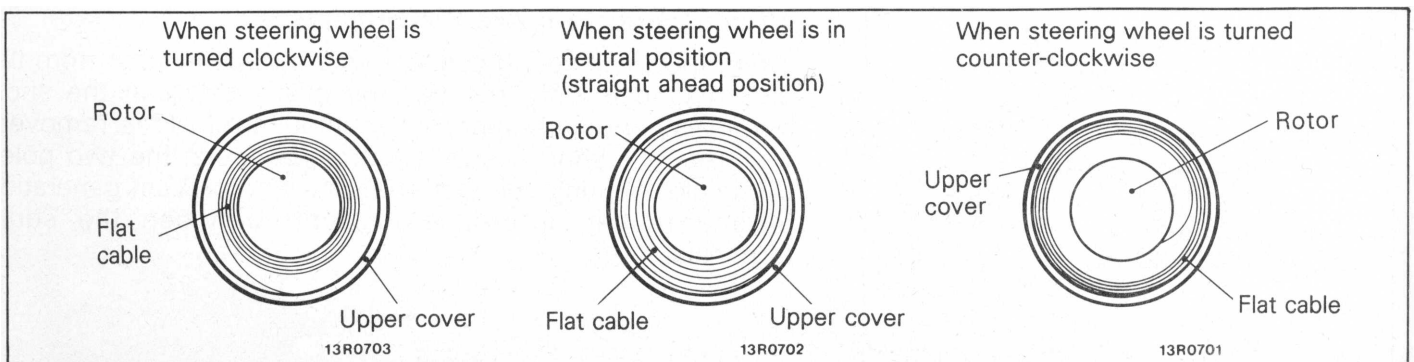

Neutral position indication mechanism

The system comprises of a ring gear (number of teeth: 90) provided in the upper case, a transparent cover mounted on the rotor with screws, and a gear (number of teeth: 80) which is in mesh with the ring gear and is driven by the convex portion of the cover.

The upper case is mounted on the steering column and is always held in position.

The rotor is coupled with the steering shaft and always operates with the steering wheel. The gear is always kept in mesh with the ring gear by the convex portion of the cover. If the rotor turns through a rotation, the convex portion of the cover also turns through a rotation. So the gear is displaced in the opposite direction to the

rotating direction of the rotor by the difference in the number of teeth between the gear and ring gear or by 10 teeth.

Markings R2, 1, NEUTRAL, 1, and 2L are made on the gear for every 10 teeth. An alignment mark is made on the upper case. The clock spring is placed in the neutral (straight ahead) position by lining up the alignment mark with the mark NEUTRAL of the gear. The mark "R" on the gear indicates that the rotor has been turned clockwise, whereas the mark "L" indicates counter-clockwise rotation of the rotor.

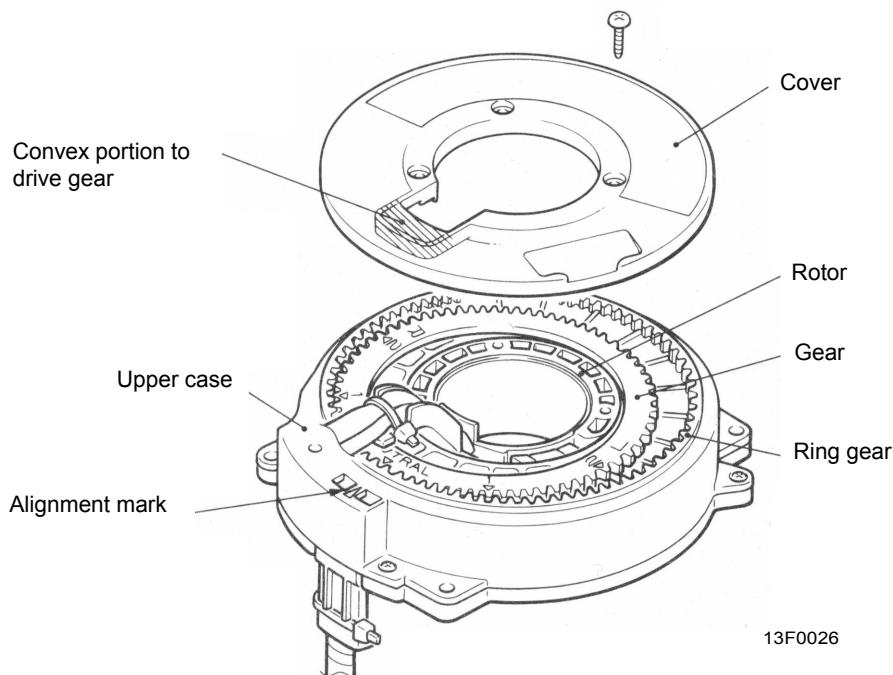

How the gear operates when the rotor is turned one rotation clockwise

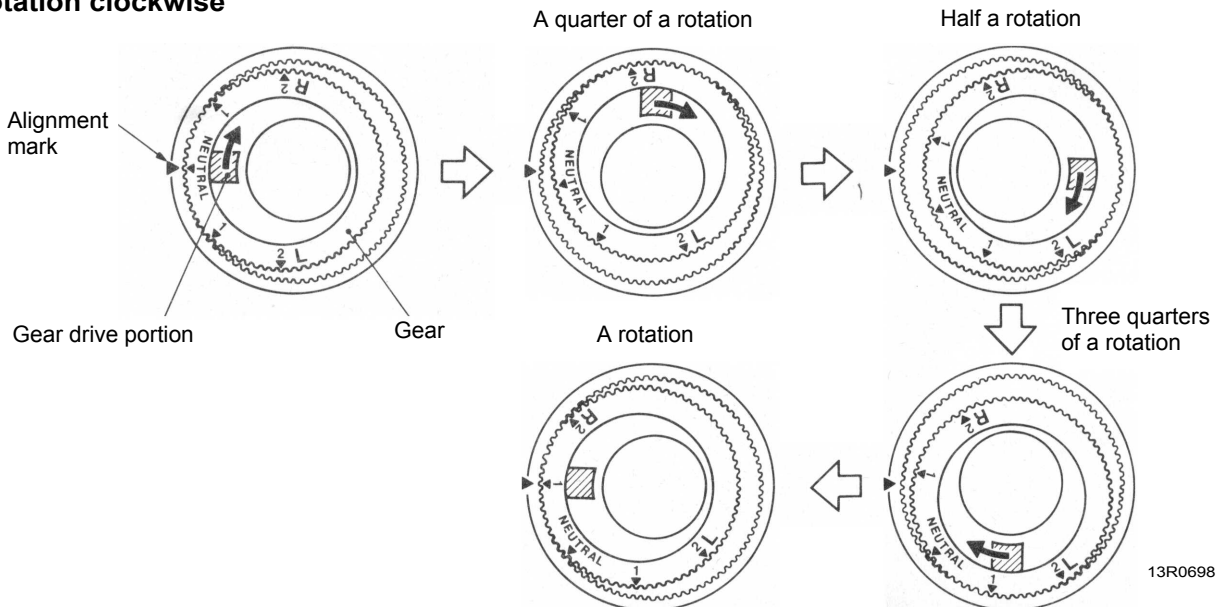

SRS WARNING LAMP

The SRS warning lamp is provided at the lower right corner of the combination meter.

When the SRS is in good order, the lamp should illuminate for approximately 7 seconds after the ignition key has been turned ON, or the engine has been started, and will then go out.

The SRS warning lamp has only one display area but contains two lamps. Even if one of the lamps is defective, the other one can be lit. The SRS warning lamp is checked by the SRS diagnosis unit for a defective lamp.

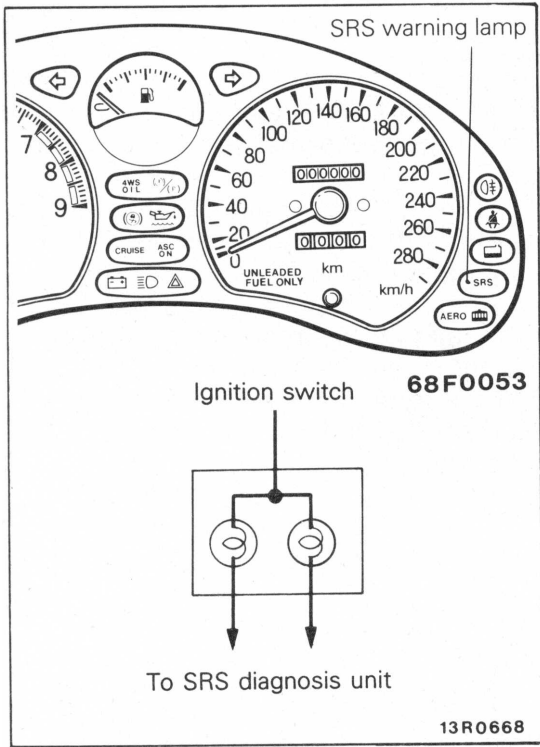

EQUIPMENT

CONTENTS

GENERAL INFORMATION ON EQUIPMENT	2	ACCESSORY SOCKET	20
Features	2	ETACS (ELECTRONIC TIME AND ALARM CONTROL SYSTEM)	21
WIRING HARNESS	3	Summary of Functions	21
Construction Diagram	3	Operation	23
DIAGNOSIS SYSTEM	4	Central Door Locking Preventing Doors From Being Locked When Ignition Key Is Left Behind	23
Diagnosis Connectors	4	Defogger Timer	24
BATTERY	5	Seatbelt Tension Reducer Timer	25
Specifications	5	Dimmer Type Lamp	26
LIGHTING	5	Seatbelt Warning Lamp	27
General Information	5	Intermittent Wiper, Mist Wiper and Washer Linked Wiper	28
Specifications	5	Input Check Facility of ETACS	29
Structural Diagram	6	Parts and Functions Related with ETACS	30
Headlamp	6	Theft Alarm System	31
Headlamp Leveling system	13	HEATERS AND AIR CONDITIONING	33
Engine Compartment Inspection Lamp	13	General Information	33
METERS AND GAUGES	14	Components	34
Combination Meter	14	Small Amount Refrigerant System	36
Combination Gauge	14	Heater Unit	37
Vehicle Speed Sensor	15	Air Conditioner Control Panel	37
Electric Type Speedometer	16	Compressor Control	38
WIPERS AND WASHERS	18	Control	40
Structural Diagram	18	Refrigerant Line	41
RADIO AND TAPE PLAYER	19	Self-diagnosis and Back-up Function	41
Structural Diagram	19		

GENERAL INFORMATION

New equipment and new functions have been added to make the equipment better.

FEATURES

Improved reliability

1. Gold plating of electronic control system terminals.
2. MWP (Multipole Water Proof type) connector.
3. Adoption of small amount refrigerant air conditioner system.

Improved visibility
and safety

1. Large combination meter.
2. High-mounted stop lamp.
3. Double action ignition switch.

Improved usability
and convenience

1. Adoption of engine compartment inspection lamp.
2. Adoption of combination gauge (3-set gauge) for a sporty feeling.

Improved serviceability

1. Diagnosis connector.
2. Ignition timing adjustment terminal.
3. Fuel pump operation check terminal.
4. Engine rpm detection terminal.
5. Adoption of one-touch plug-in method for easy installation and removal of combination meter.
6. Centralization of control harnesses and sensor connections.
7. Adoption of indicator lamp to show LOW position of front washer fluid.
8. Adoption of level gauge for easy inspection of amount of fluid in rear washer tank.

Improved marketability

1. Adoption of electric type speedometer for smooth, shake-free pointer movement in response to speed changes.
2. Adoption of accessory socket.
3. Adoption of theft-alarm system <Vehicles for Europe>

WIRING HARNESS

The wiring harness is divided into the main wiring harnesses [front wiring harness, body wiring harness (LH, RH), control wiring harness, instrument panel wiring harness] and sub wiring harnesses (door wiring harness, tailgate wiring harness, roof wiring harness) and has the following characteristics.

- A junction block, which is one unit consisting of intermediate connectors for the harnesses, fuse boxes and relay boxes, is used to improve reliability.

- CAVS (Compressed Conductor Automobile Vinyl Semi-rigid Wire) is used for the electrical wiring harness to make it lighter.
- There is central connector (diagnosis connector) for diagnosis inspection of each electronic control system for improved serviceability.
- Connector terminals in the control units and sensors where weak electric current from the electronic control systems flows are gold-plated to assure flow of current.

STRUCTURAL DIAGRAM

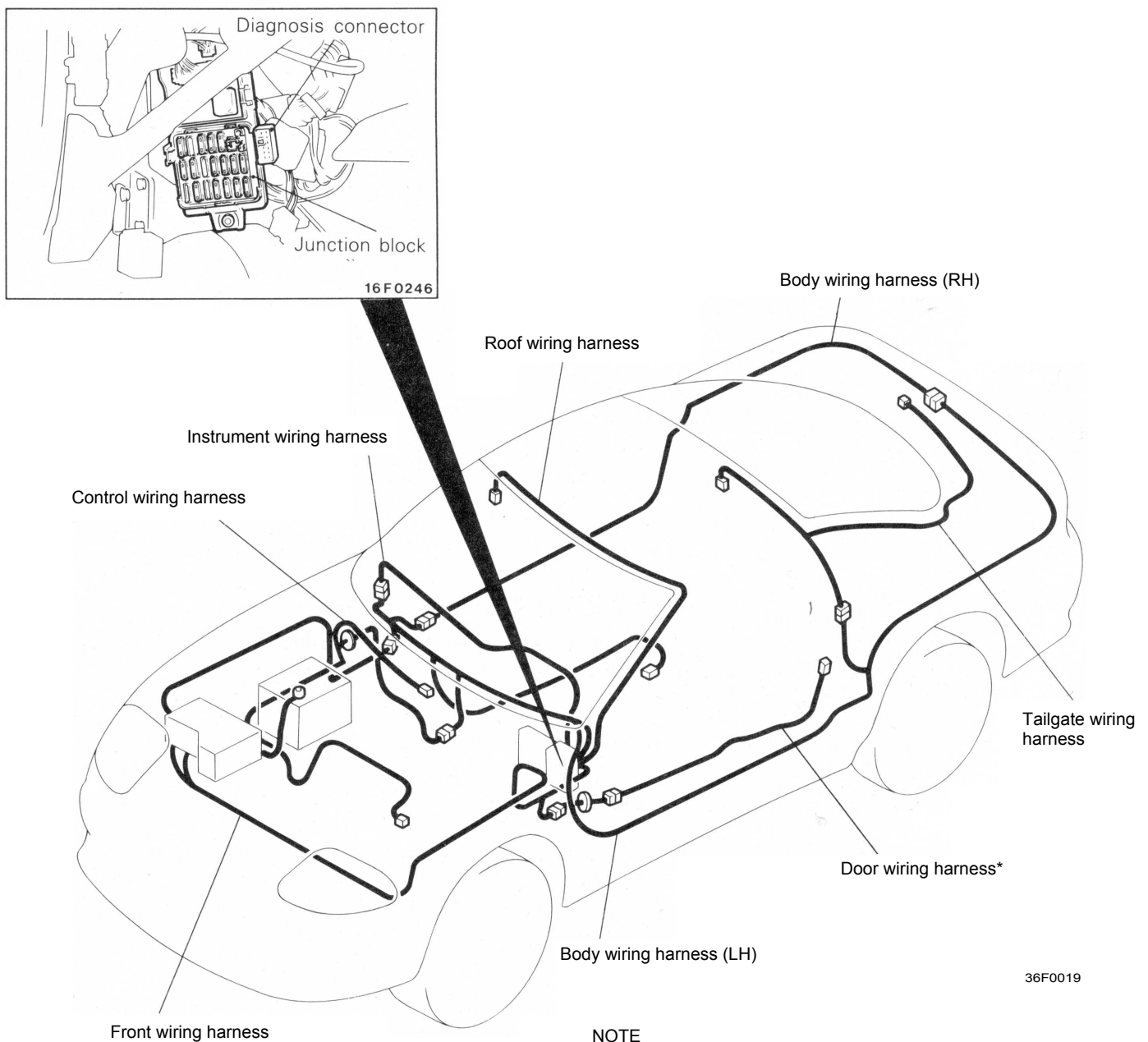

NOTE

- (1) This figure shows the main wiring harnesses only.
- (2) * mark indicates it is equipped on the right side also.

DIAGNOSIS SYSTEM

Diagnosis system is designed to improve serviceability and has the following functions

Function	Pulse check	Input inspection (same display pattern as diagnosis code)	Diagnosis memory save
Electronics system			
(1) MPI			○ Until battery OFF
(3) ECS			○ Until battery OFF
(4) ABS			○ Until battery OFF
(5) Cruise control		○	○ Until battery OFF
(6) Full auto air conditioner			○ Until battery OFF
(7) ETACS	○		
(8) THEFT ALARM	○		
(9) SRS (AIR BAG)			EEPROM*

NOTE

*: Saved in memory as long as the data is not electrically canceled.

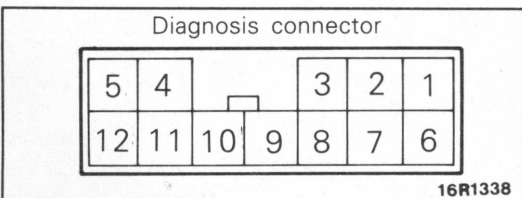
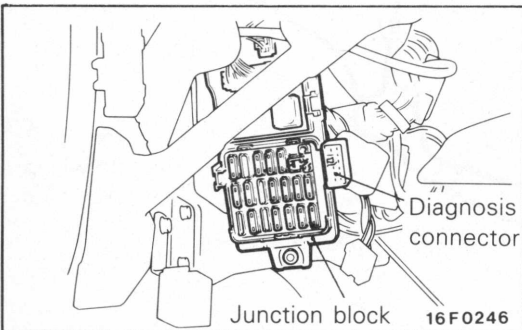

DIAGNOSIS CONNECTOR

The diagnosis connector for the following systems is located on the right side of the junction block.

1. MPI
2. -
3. ECS
4. ABS
5. Cruise control
6. -
7. Full auto A/C
8. SRS (Air Bag)
9. ET ACS (Theft Alarm)
10. Diagnosis control
11. Vehicle simulated speed
12. Earth

BATTERY

The battery of the following specifications has been established.

SPECIFICATIONS

Items	STANDARD	OPTIONAL
		<Except vehicles for Australia>
Type	55D23R-MF	75D26R-MF
Capacity (5H R) Ah	50	52
Reserve capacity min.	99	123
Cold cranking current A	300	490

LIGHTING

GENERAL INFORMATION

Parallel link type pop-up headlamp that go up and down vertically are used. Air resistance when driving is reduced by the aerodynamic shape.

There is also a convenient engine compartment inspection lamp for inspecting at night and for service to improve serviceability.

SPECIFICATIONS

Items	Specifications
Exterior lamps	
Headlamps	W 65/45
Fog lamps or driving lamp	W 35
Clearance lamp	W 5
Front combination lamp	J
Turn-signal lamp/position lamp	W 21/5
Side turn signal lamp	W 5
Rear combination lamp	
Turn-signal lamp	W 21
Stop lamp/tail lamp	W 21/5
Rear fog lamp	W 21
Back-up lamp	W 21
Licence plate lamp	W 5
High-mounted stop lamp	W
Vehicles for Europe	W 5 x 3
Vehicles for General Export	W 5 x 3 or LED (Light Emitting Diode)
Vehicles for Australia	W LED (Light Emitting Diode)
Engine compartment inspection lamp	W 3.8
Interior lamps	
Foot lamps	W 3.4
Room lamp	W 8
Door courtesy lamp	W 5
Glove box lamp	W 3.4

STRUCTURAL DIAGRAM

<Vehicles for Europe>

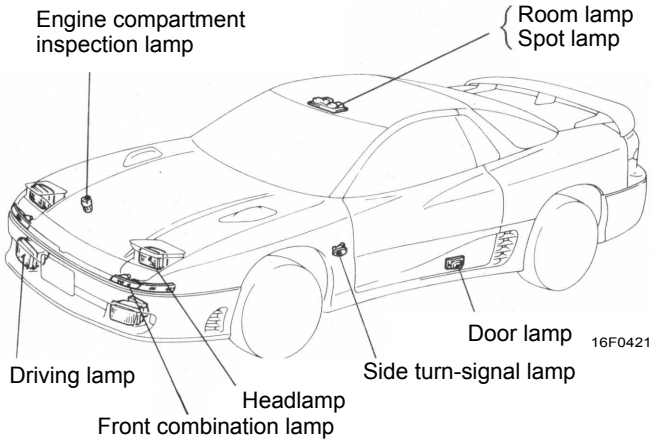

<Vehicles for General Export and GCC>

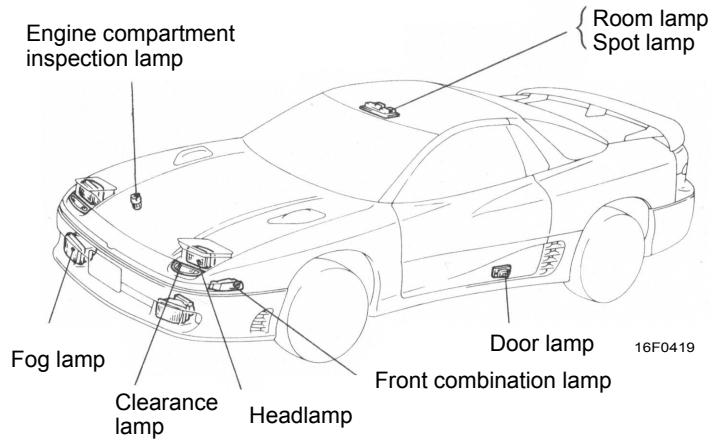

<Vehicles for Australia>

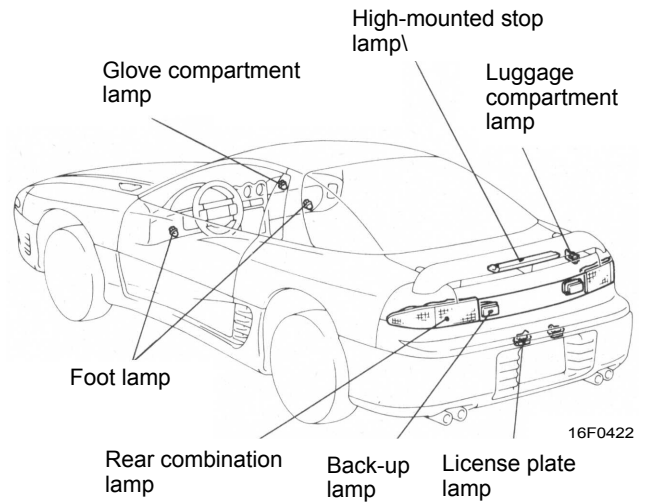
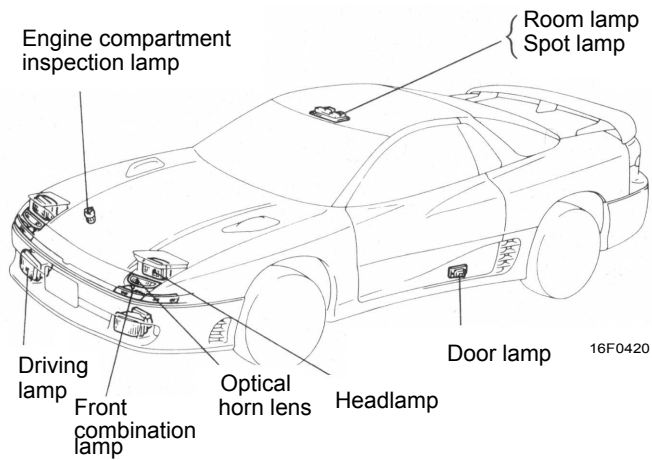

HEADLAMP

The headlamps go up and down when the lighting switch or pop-up switch is operated. The operating mechanism for the head lamps is such that the right and left head lamps operate independently so that if

there should be trouble in one side, the other side can still operate. Furthermore, when there is trouble in the electric system, there is a manual knob so the headlamps can be moved up and down manually.

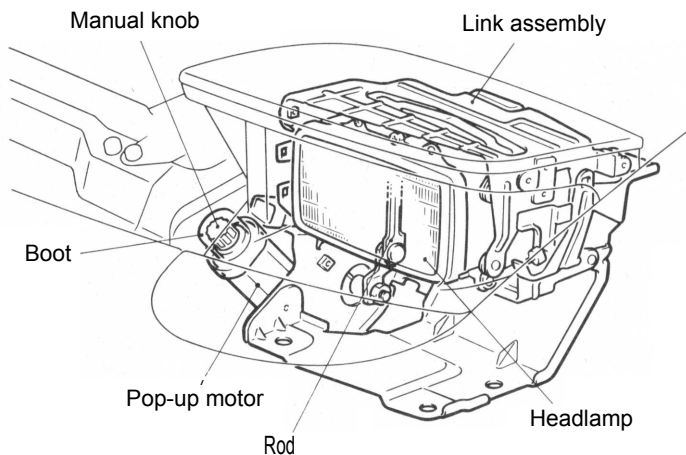
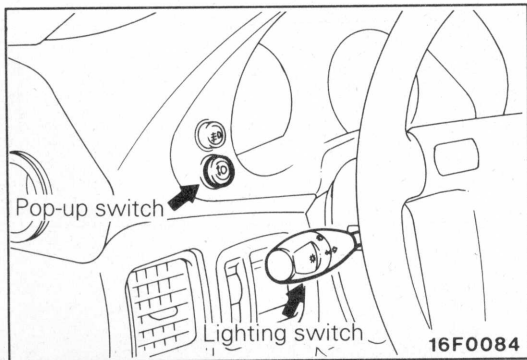

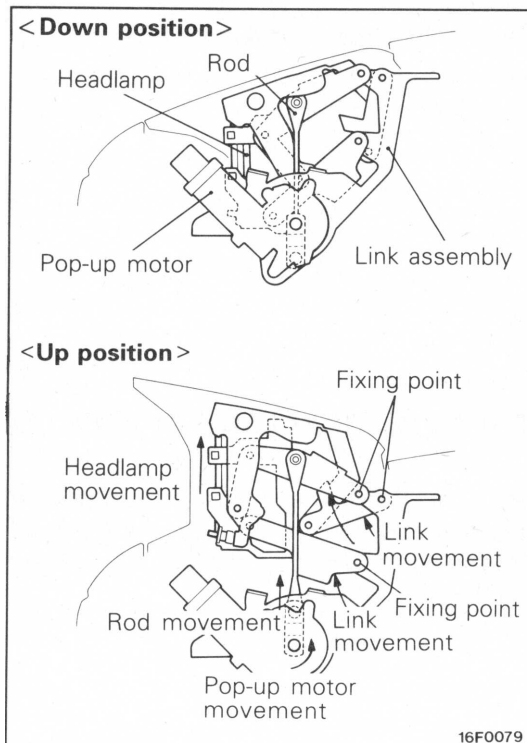

EXPLANATION OF STRUCTURE

Pop-up Headlamp

The pop-up head lamp consists of the pop-up motor, link assembly, rod connecting the pop-up motor and link assembly, and head lamp to raise and lower the headlamp.

When the pop-up switch or lighting switch is turned ON, the pop-up motor rotates, the rod connected to the pop-up motor moves the link assembly to raise the headlamp. The link assembly uses a parallel link system so each link operates through the three fixing points on the right and left to raise and lower the headlamp vertically.

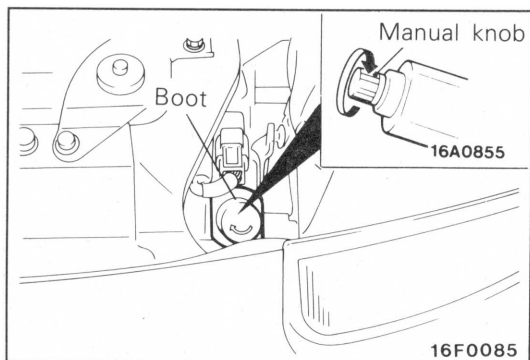

Manual Knob

When the headlamp pop-up mechanism does not function due to trouble in the electric system, this manual knob can be used to turn the pop-up motor to raise and lower the head lamp manually.

The manual knob is operated by removing the boot and turning the manual knob clockwise.

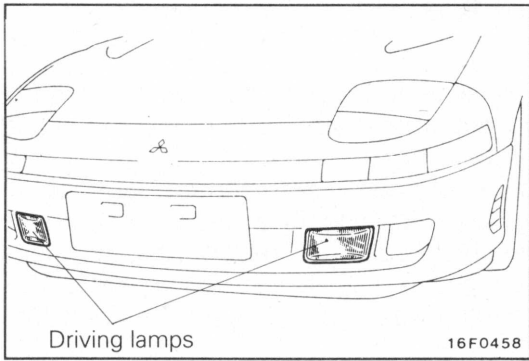

Driving Lamp <Vehicles for Europe and Australia>

The driving lamps come on when the head lamps are flashed for passing or when the headlamp switch is turned to the high beam.

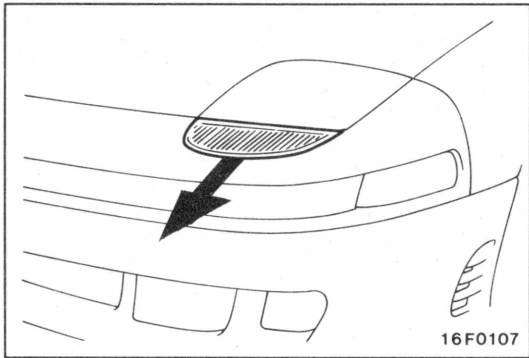

OPTICAL HORN LENS (FOR PASSING LAMP IN VEHICLES FOR AUSTRALIA)

Since the head lamp faces the front even when retracted, the head lamp, if used when passing, lamps up and shines in retracted condition through the optical horn lens (place for the lens so lamp can pass through).

OPERATION

Headlamp and Driving Lamp Operating Conditions <Vehicles for Europe and Australia>

Headlamp and driving lamp operation or position				Headlamp				Driving lamp	
				UP	DOWN	ON	OFF	ON	OFF
Pop-up switch	ON	Lighting switch	ON	<input type="radio"/>		<input type="radio"/>		<input type="radio"/>	When head-lamps are on high beam
			OFF	<input type="radio"/>			<input type="radio"/>		<input type="radio"/>
		Passing switch	ON	<input type="radio"/>			<input type="radio"/>		
			OFF	<input type="radio"/>			<input type="radio"/>		<input type="radio"/>
	OFF	Lighting switch	ON	<input type="radio"/>				<input type="radio"/>	When head-lamps are on high beam
			OFF		<input type="radio"/>		<input type="radio"/>		<input type="radio"/>
		Passing switch	ON		<input type="radio"/>			<input type="radio"/>	
			OFF		<input type="radio"/>			<input type="radio"/>	<input type="radio"/>

NOTE

"O" indicates the resultant headlamp operation or position. When the lighting switch is ON, it is in the "HEAD" position.

<Vehicles for General Export and GCC>

Switch position				Headlamp operation and position			
				Headlamp	Headlamp	Headlamp	Headlamp
				Raise	Lower	ON	OFF
Pop-up switch	ON	Lighting switch	ON	○		○	
			OFF	○			○
		Passing switch	ON	○		○	
			OFF	○			○
	OFF	Lighting switch	ON	○		○	
			OFF		○		○
		Passing switch	ON	○		○	
			OFF		○		○

NOTE
 "○" indicates the head lamp operation or position resulting from switch operation. Lighting switch ON means that the head-lamps are in the illumination position.

Raising Headlamp

When the Pop-up Switch is Turned From OFF to ON and the Lighting Switch is OFF or at TAIL

When the pop-up switch is turned ON, the judgment circuit in the ETACS control unit senses the ON signal and activates the UP timer circuit. Then, since transistor Tr1 is turned ON, transistor Tr2 is also ON, current from transistor Tr2 flows through the U-contact in the pop-up motor U/D (UP/DOWN) switch and from the pop-up motor relay (coil side) to earth, the pop-up motor relay

(contact side) goes ON, current flows in the pop-up motor and the headlamp starts to go up.

When the crank arm rotates approximately 180° and reaches the UP position where it stops automatically, current to the pop-up motor is cut off since the connecting U/D switch contact changes from the U-contact to the D-contact, the pop-up motor stops and the head lamp remains in the up position.

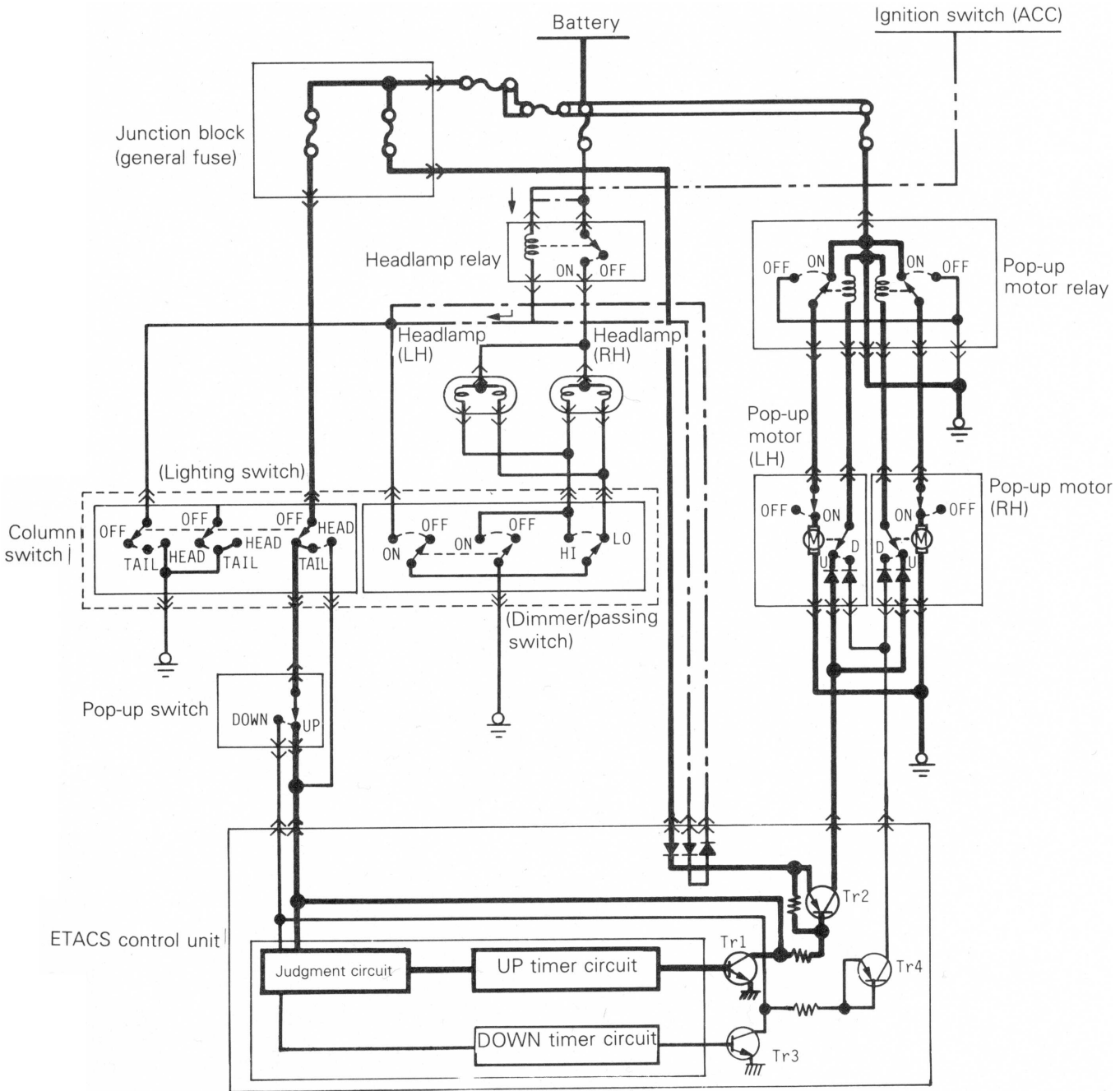

16F0109

NOTES

- (1) The dotted line (— — — —) indicates a model with the theft-alarm system installed.
- (2) The two-dotted line (— · — · —) indicates models without a theft-alarm system.

When the Pop-up Switch is OFF and the Lighting Switch is Turned OFF or From TAIL to HEAD

When the lighting switch is turned to HEAD (on models without the theft-alarm system, lighting switch is turned to HEAD after the ignition switch is turned to ACC), current flows from the headlamp relay (coil side) to earth via the column switch (lighting switch),

the head lamp relay (contact side) goes ON, current flows in the headlamp, the judgment circuit in the ETACS control unit senses the ON signal at the same time as the headlamp lights up, and just as in the item mentioned on the previous page, the pop-up motor relay goes ON and the head lamp goes up.

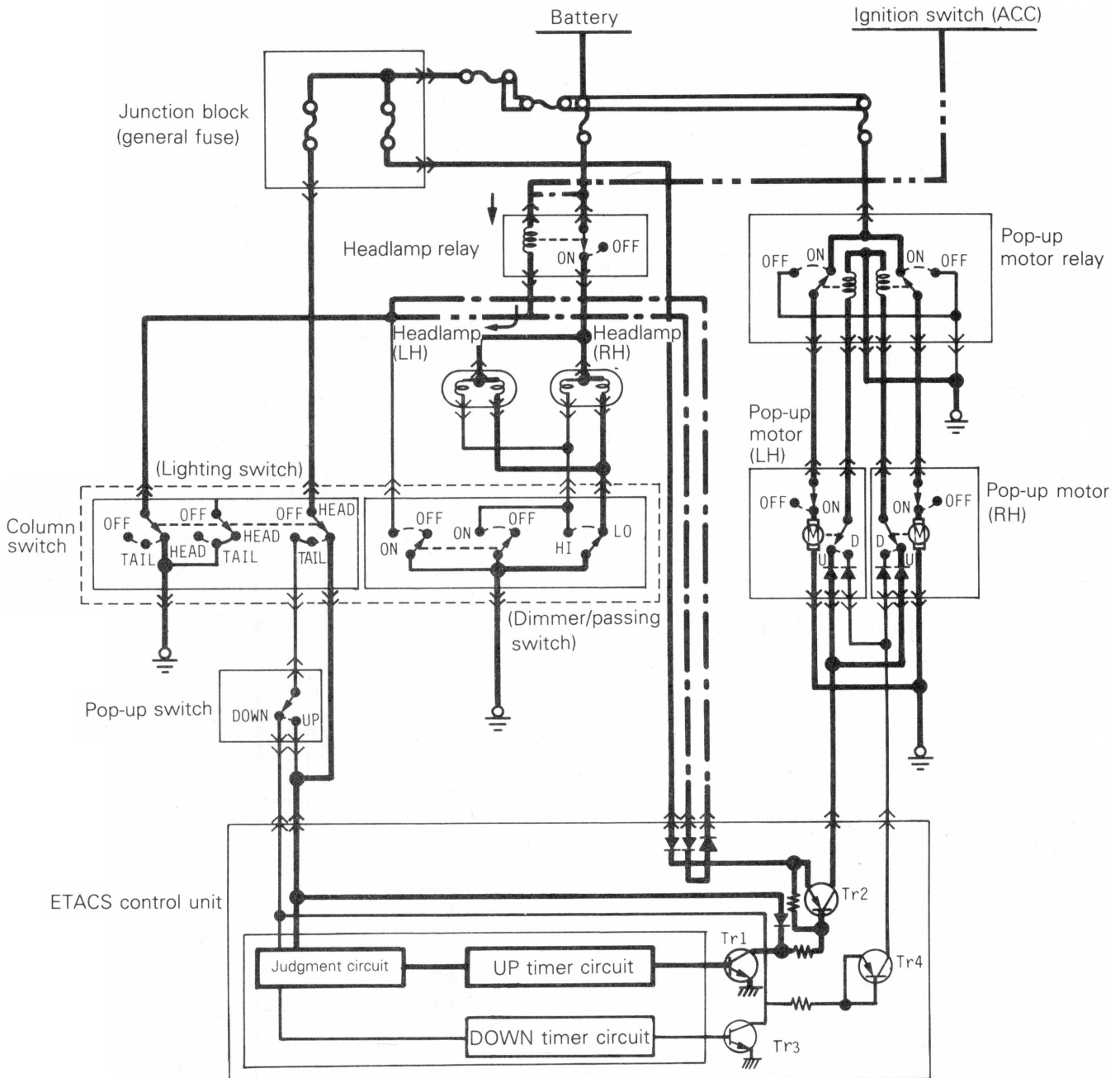

16F0110

NOTES

- (1) The dotted line (— — — —) indicates a model with the theft-alarm system installed.
- (2) The two-dotted line (- - - - -) indicates models without a theft-alarm system.

**Lowering Headlamp
When the Pop-up Switch is Turned From ON to OFF and the Lighting Switch is OFF or at TAIL**

When the pop-up switch is turned OFF, the judgment circuit in the ETACS control unit senses the OFF signal and the DOWN timer circuit functions. Then, transistor Tr4 also is ON since transistor Tr3 is turned ON, current from transistor Tr4 passes through D-contact in the U/D (UP/DOWN) switch and flows from the pop-up motor relay (coil side) to earth, the pop-up motor relay (contact side) goes ON, current flows to the pop-up motor and the headlamp starts to go down. Since the connecting U/D (UP/DOWN) switch contact changes from the D-contact to the U-contact when the pop-up motor rotates approximately 180° and reaches the position for auto-

matically stopping the down movement, current to the pop-up motor is cut off, the pop-up motor stops and the headlamp stays in the down position.

When the Pop-up Switch is OFF and the Lighting Switch is Turned from HEAD to TAIL or OFF

When the lighting switch is turned to TAIL or OFF, current to the headlamp relay (coil side) is cut off, the headlamp relay (contact side) goes OFF and the judgment circuit in the ETACS control unit senses the OFF signal at the same time as the headlamp is extinguished and, just as in the item mentioned above, the pop-up motor relay goes ON and the head lamp goes down.

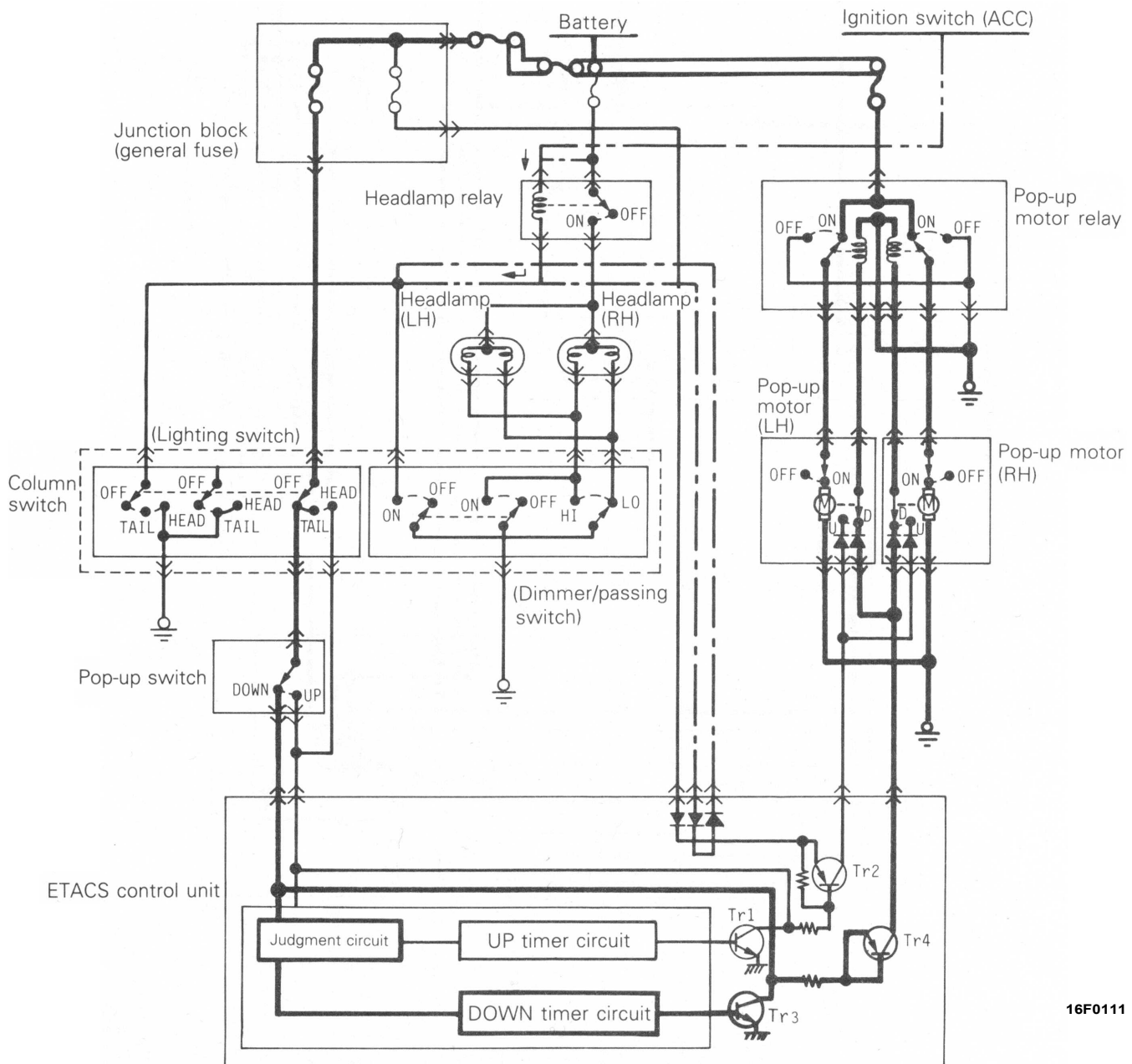

16F0111

NOTES

- (1) The dotted line (— — —) indicates a model with the theft-alarm system installed.
- (2) The two-dotted line (- - - -) indicates models without a theft-alarm system.

HEADLAMP LEVELING SYSTEM

The headlamps leveling system is a system that the driver can, if desired, use to change the head lamps illumination angle in the vertical direction so as to prevent approaching vehicles from being subjected to excessive brightness due to a change in the attitude of this vehicles because of the number of people or the amount of load carried. This system is composed of the headlamp leveling unit (installed to the rear of the head lamps) and the headlamp leveling switch (located at the lower left part of the instrument panel). When the headlamps are illuminated, the illumination angle in the vertical direction (lower beam only) can be set to anyone of four steps by using the headlamp leveling switch.

NOTE

For the construction and operation of the headlamp leveling system, refer to the 1990 LANCER HATCHBACK Technical Information Manual.

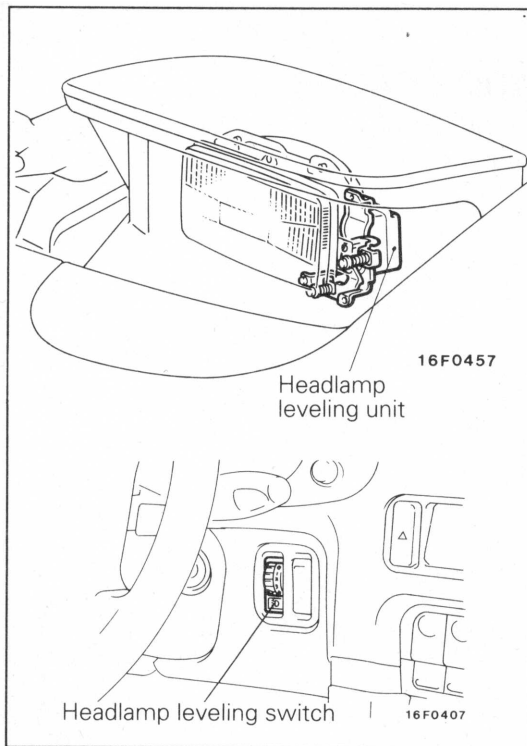
**ENGINE COMPARTMENT INSPECTION LAMP**

When the hood is opened with the lighting switch in the TAIL or HEAD position, the inspection lamp switch goes ON, the inspection lamp in the hood lamps up to illuminate the engine compartment.

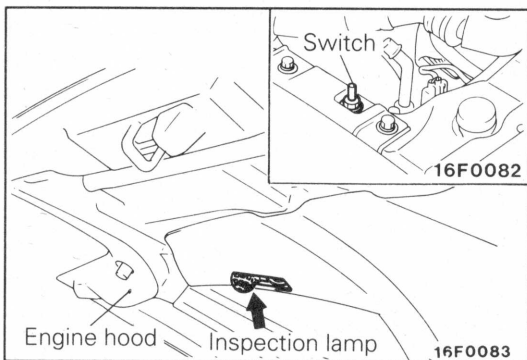

METERS AND GAUGES

COMBINATION METER

The combination meter uses analogue meters that are large, and easy-to-read, indicator lights and warning lights. The speedometer is an electric type that is operated by pulse signals from the vehicle speed sensor so the pointer moves smoothly in response the speed variations without pointer shaking.

COMBINATION GAUGE

The combination gauge used is a 3-set gauge type with sporty feeling.

<Vehicles for Europe>

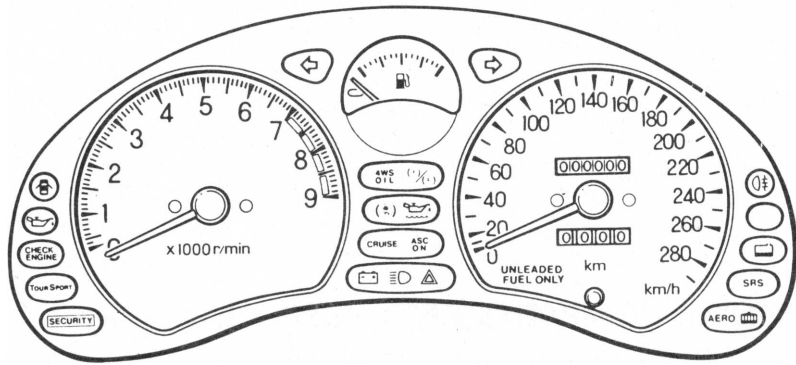

68F0053

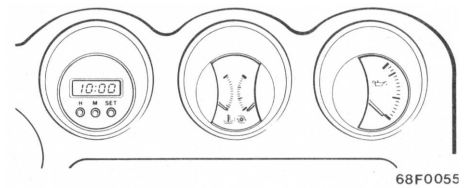

68F0055

<Vehicles for General Export and GCC>

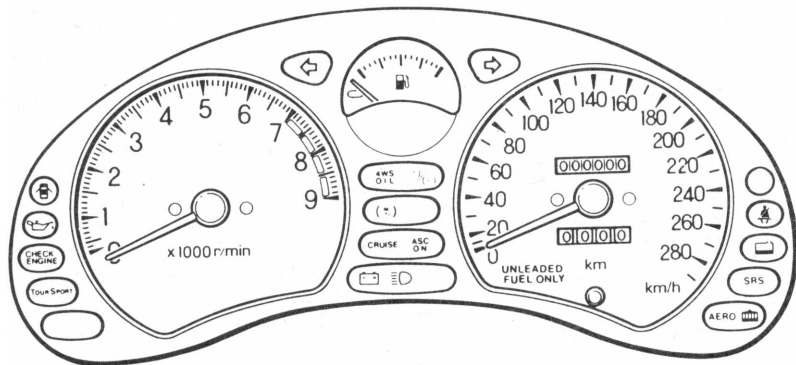

68F0053

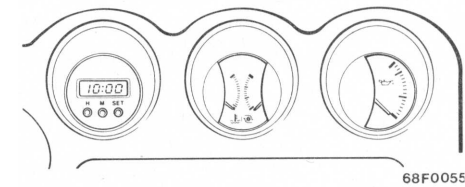

68F0055

<Vehicles for Australia>

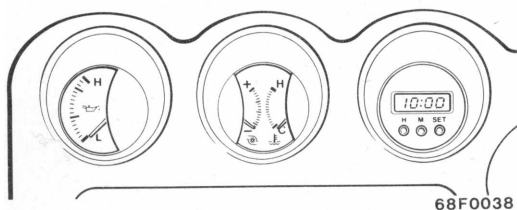

68F0038

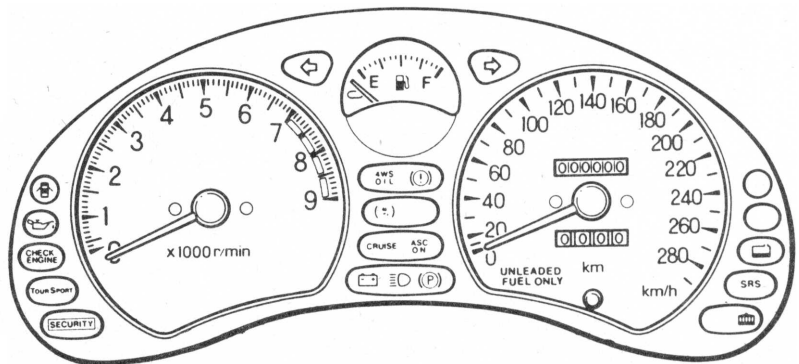

68F0054

**VEHICLE SPEED SENSOR
STRUCTURE**

The rotating shaft of the vehicle speed sensor is mounted directly on the transmission speedometer driven gear. The rotation of the driven gear is transmitted to a magnet via the rotating shaft. The IC built into the

Magneto Resistive Element (MRE) in the top of the magnet detects the rotation of the magnet and generates a 4-pulse electric signal for each rotation of the speedometer driven gear.

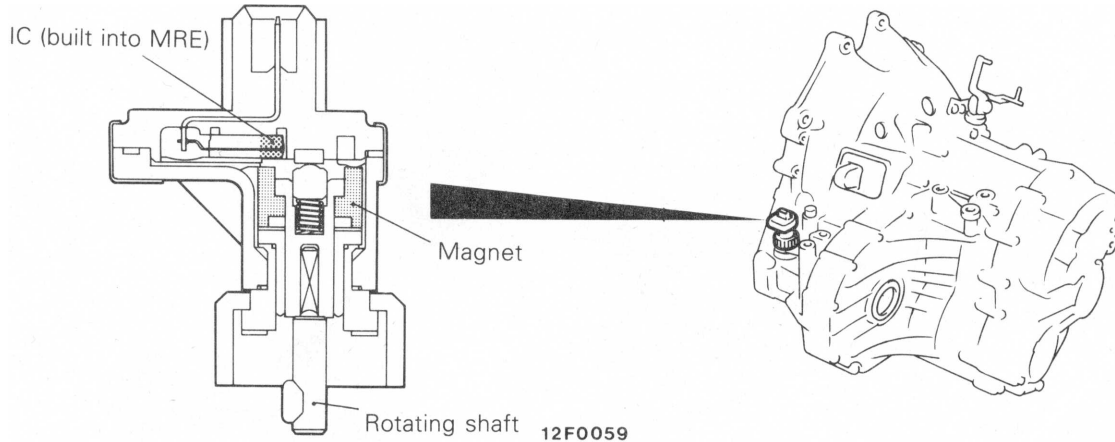

MAGNETO RESISTIVE ELEMENT (MRE)

Characteristics

The magneto resistive element (MRE) has the characteristic that its resistance value varies according to the direction of the magnetic field. When the direction of the magnetic field is parallel to the Magneto Resistive Element (MRE), the resistance value is maximum; when

the direction of the magnetic field is vertical to the Magneto Resistive Element (MRE), the resistance value is minimum.

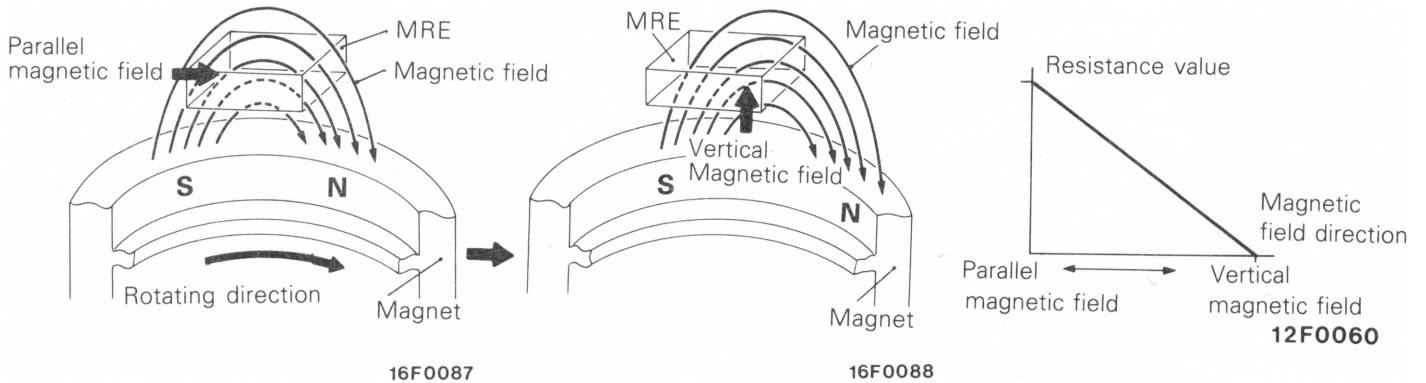

Operation

Since the resistance value of the MRE varies with the variations in the magnetic field when the magnet rotates, the output voltage also varies. The shape of the wave of this output voltage is shaped by the comparator and then, after it is divided by the frequency divider circuit

into a 1rotation, 4-pulse signal, the transistor turns it ON-OFF when it is output to the transistor base to produce a 4-pulse electric signal per one rotation of the speedometer driven gear.

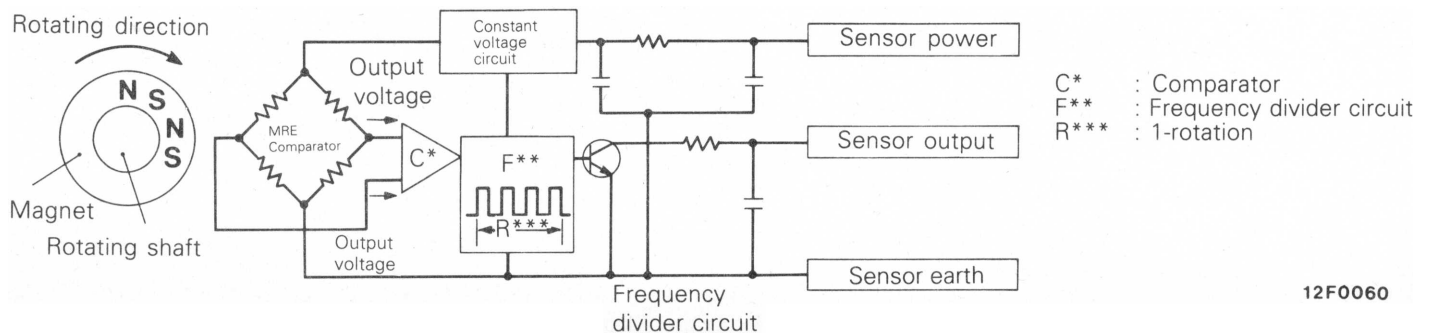

ELECTRIC TYPE SPEEDOMETER

CONSTRUCTION

The electric type speedometer uses an electronic circuit to control the electric signal from the vehicle speed sensor and a cross coil type speedometer that has a magnet fixed to the pointer shaft and two coils

that pass directly through it. Furthermore, the odometer and trip meter are directly driven by the stepping motor with built-in gear.

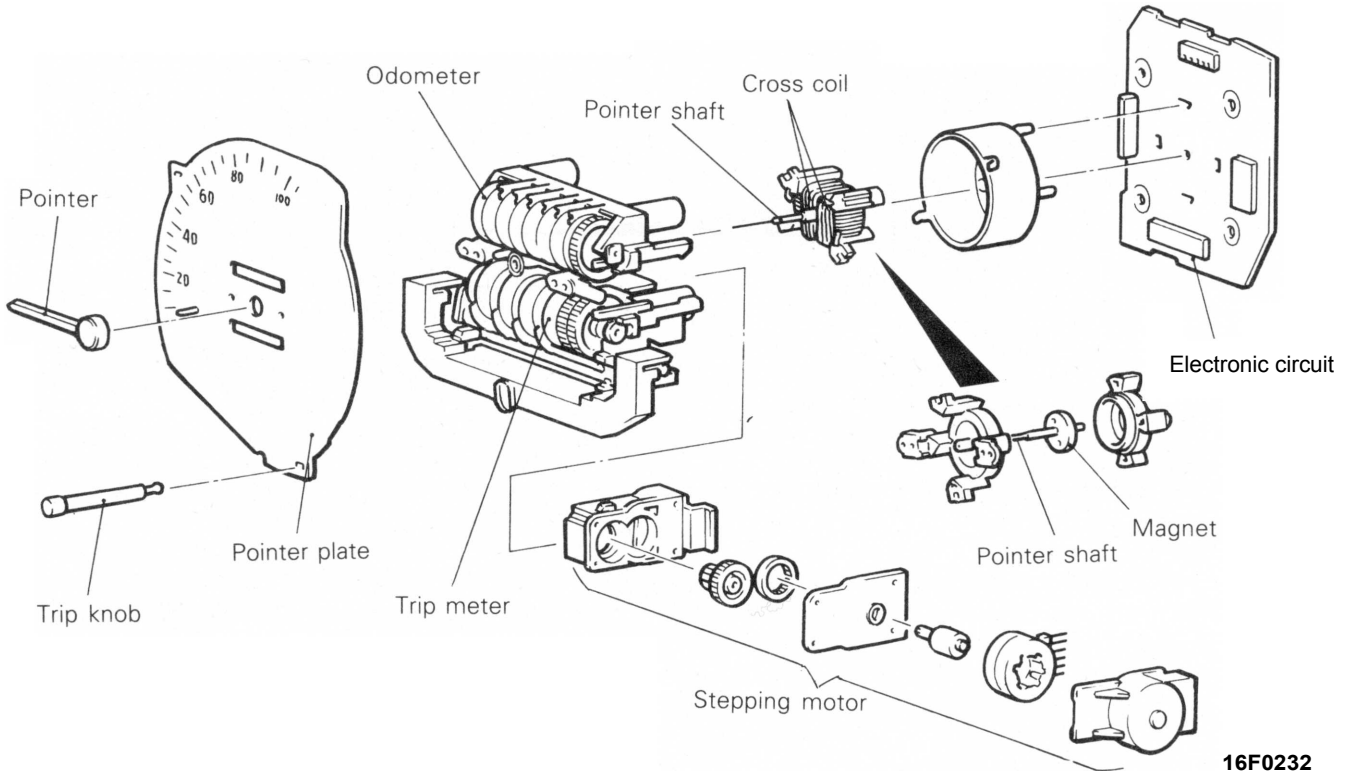

16F0232

OPERATION

Electronic Circuit

It shapes the wave of the electric signal from the vehicle speed sensor in the shaping circuit and, after calculating vehicle speed at the calculation circuit, it controls current flow to the cross coil and stepping motor.

It determines the direction of current flowing in each cross coil by using the quadrant indicating circuit and, at the same time, it determines the current value

using the duty data circuit, and sends current from the meter drive circuit to drive the pointer.

It determines the current value flowing to the stepping motor by using the pulse motor data circuit, and sends current from the pulse motor drive circuit to drive the odometer and trip meter.

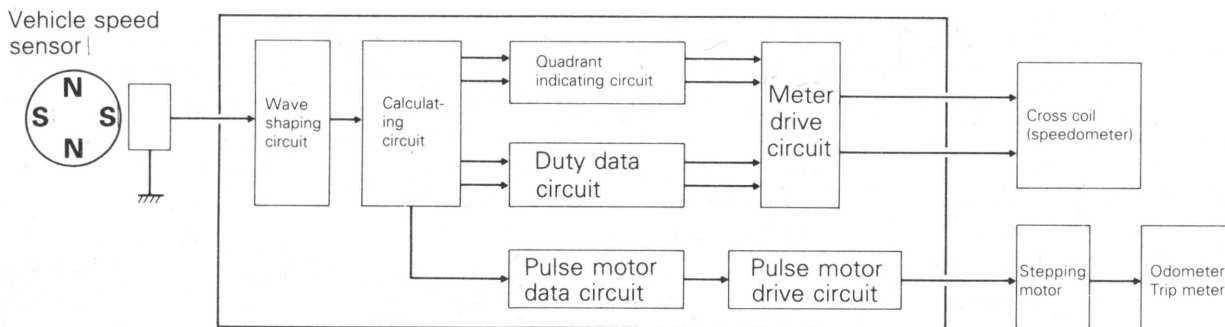

16F0233

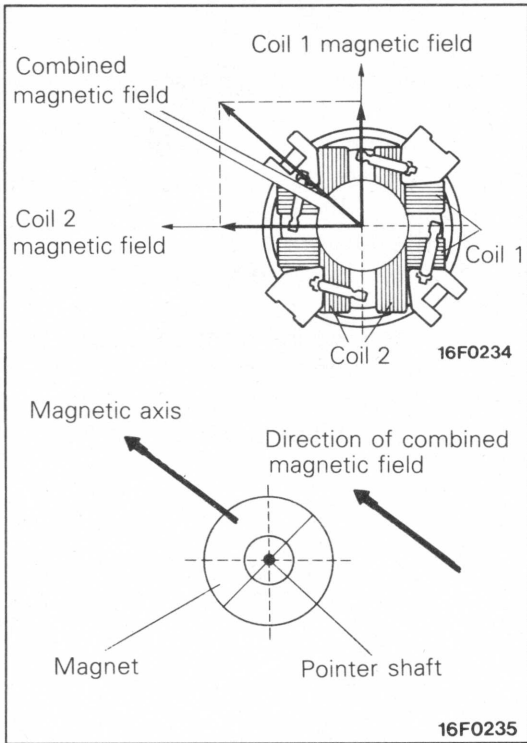

Cross Coil

When current flows in the cross coil, a magnetic field is generated in coil 1 and coil 2. Since the two magnetic fields pass directly through, the actual magnetic field is a combination of the two magnetic fields. Since the magnet is fixed to the pointer shaft, the magnet rotates to try to align the magnetic axis of the magnet in the direction of the combined magnetic field and thus rotates the speedometer pointer.

NOTE

The speedometer pointer is attached to the pointer shaft 20° counterclockwise to the magnetic axis of the magnet.

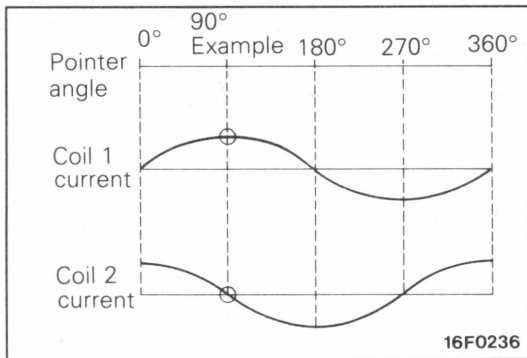

RELATION BETWEEN POINTER ANGLE AND CURRENT VALUE

The angle of the pointer is determined by a variation of the current value flowing in coil 1 and coil 2.

Example:

- When the pointer is at 90°
- Maximum current flows in coil 1.
 - No current flows in coil 2.

NOTE

When the pointer is at an angle of 0°, it indicates a speed of 0 km/h (0 mph).

WIPER AND WASHER

The front wiper is a semi-concealed type with the following features.

- A variable time intermittent wiper under ETACS control is used on all models. (Refer to ETACS for operation of the variable time intermittent wiper.)
- There is a mist wiper function for more convenience.
- The washer is a 2-nozzle 4-jet type and there is a level gauge switch to inform by an indicator lamp in the combination meter that the washer in the washer tank is low. The rear wiper is used for improved rear

visibility when it rains, etc. It has the following additional features.

- It uses a fixed time intermittent wiper.
- The washer is a 1-nozzle 2-jet type and there is a level gauge in the washer tank for easy detection of the amount of liquid. It is mounted in the right rear of the cargo compartment.
- The wiper/washer switch is mounted on the right side of the knee protector. It is a combination wiper/washer switch and can be operated when the ignition switch is at ACC or ON.

STRUCTURAL DIAGRAM

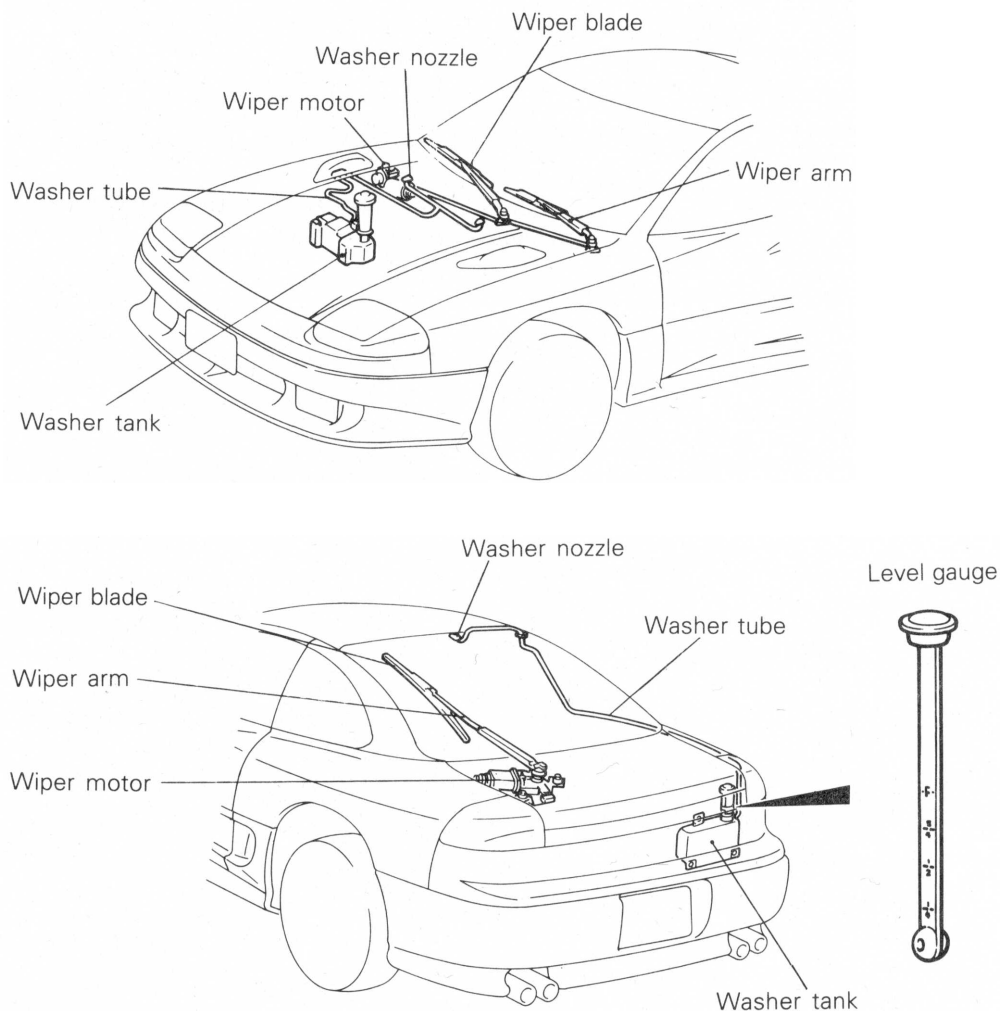

RADIO AND TAPE PLAYER

There are two types of AM/FM multi-electronic tuning radios for the radio and stereo .

- 6 speakers (front speaker: single cone for high-frequency sound, door speaker: double cone for high/low-frequency sound, rear speaker: single cone for high/low-frequency sound)

- 7 stop retractable motor driven antenna with a total length of 900mm (35.4 in.).

STRUCTURAL DIAGRAM

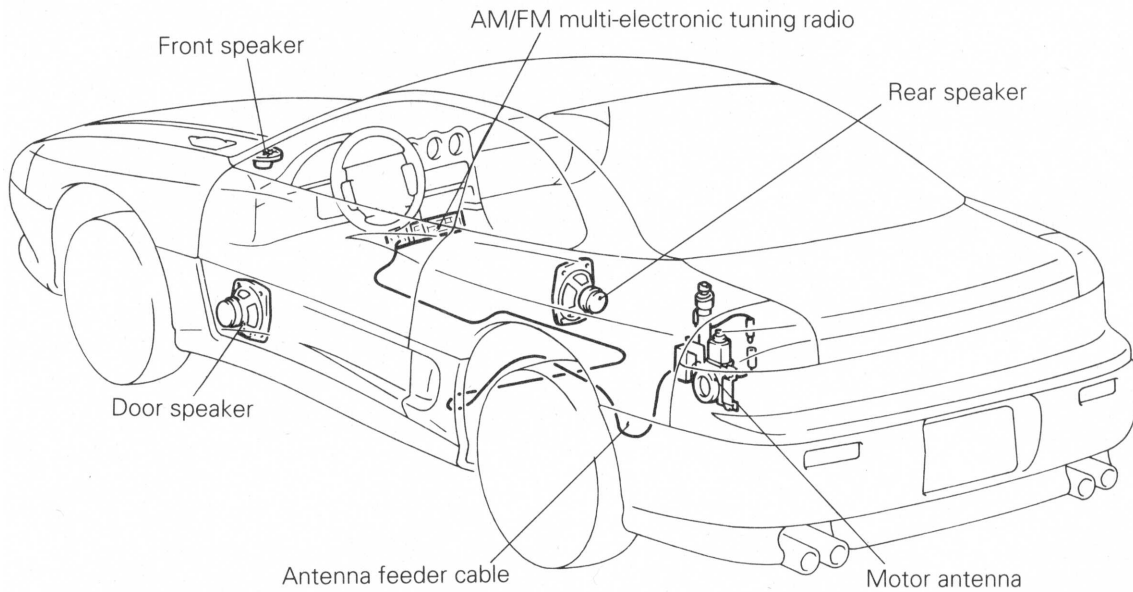

16F0414

NOTE

Speakers are also installed on the right side.

AM/FM multi-electronic tuning radio and tape player

Type 1

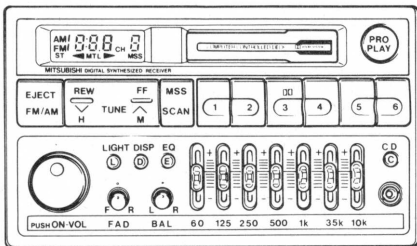

70F0019

Type 2

Vehicles for Europe

LW/MW/FM electronic tuning radio with tape player (1 DIN)

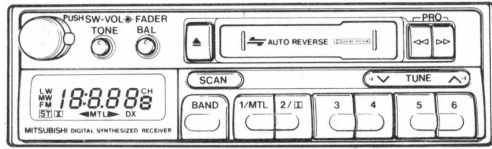

16N0598

Vehicles for General Export, GCC and Australia

AM/FM electronic tuning radio with tape player (1 DIN)

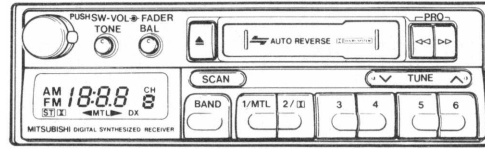

16N0597

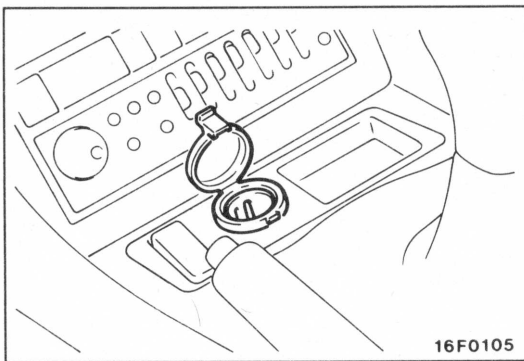

ACCESSORY SOCKET

There is a convenient accessory socket for use when using plug-in type accessories. The maximum load that can be used is 120W.

ETACS (ELECTRONIC TIME AND ALARM CONTROL SYSTEM)

ETACS (Electronic Time and Alarm Control System) is adopted and uses a micro-computer for centralized control of all timer and alarm functions.

This control unit has an input check function to check normality or abnormality of the circuit from the input switch to micro-computer in the control unit.

SUMMARY OF FUNCTIONS

Item	Functions and operations	
<p>Prevention of door lock when key is left in ignition</p>	<p>When the key is left in the ignition key cylinder, if the driver's side door is opened and an attempt is made to lock the door lock knob, the unlock output works for 5 seconds to prevent the door from locking.</p>	<p>Key reminder switch: OFF, ON</p> <p>Driver's door switch: OFF (closed), ON (open)</p> <p>Driver's door lock switch: OFF (LOCK), ON (UNLOCK)</p> <p>UNLOCK output: ON, OFF (pulses of 5 sec.)</p>
<p>Defogger timer</p>	<p>When the ignition switch is ON, if the defogger switch is turned ON, the defogger output turns ON for 11 minutes.</p>	<p>Defogger: ON, OFF (Approx. 11 min.)</p> <p>Defogger switch: ON, OFF</p> <p>16R0096</p> <p>16F0303</p>
<p>Seat belt tension reducer timer</p>	<p>When the ignition key is turned OFF, the ETACS timer function is activated, and the seat belt tension reducer functions for 30 seconds. The seat belt tension reducer timer stops, however, if a door is opened within 30 seconds.</p>	<p>Ignition switch: ON, OFF</p> <p>Door switch: OFF (closed), ON (open)</p> <p>Tension reducer output: ON, OFF (30 sec.)</p> <p>16F0302</p>

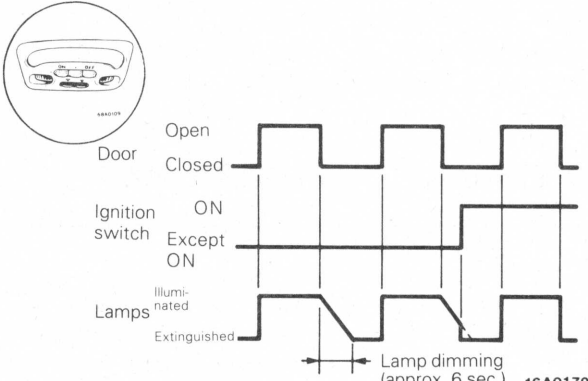
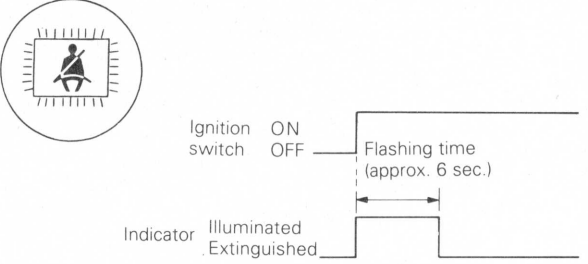
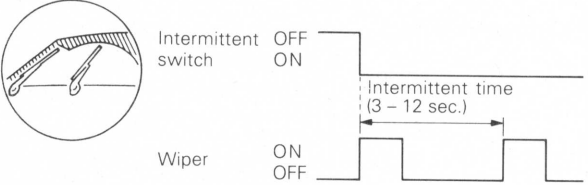
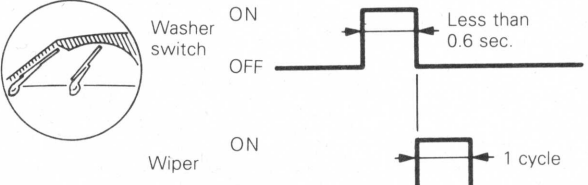
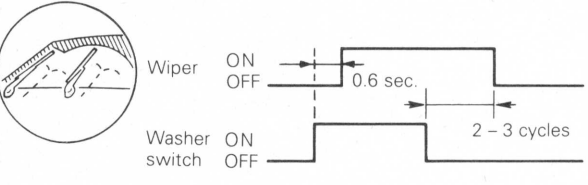
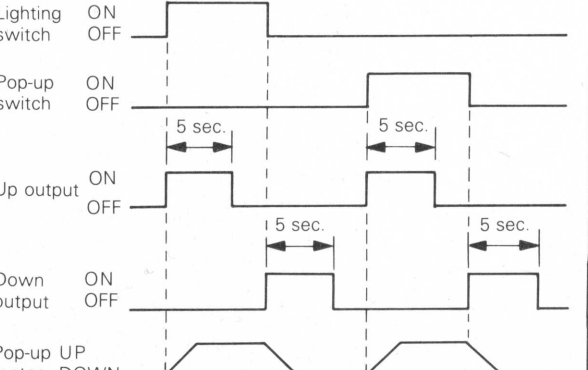
Items	Functions and operations	
<p>Dimming lamps room lamp, foot lamp, ignition key cylinder illumination lamp)</p>	<p>Except when the ignition switch is ON, if the room lamp is in the position connecting it to the door, the lamps dim gradually and go out completely after approximately 6 seconds when the door is closed.</p> <p>NOTE If the ignition switch is on, there is no dimming of the lamps when the door is closed.</p>	 <p>16A0179</p>
<p>Seat belt warning (except vehicles for Europe)</p>	<p>When the ignition key is turned ON, the seat belt warning lamp flashes for approximately 6 seconds (approximately 4 times).</p>	 <p>16R0094</p> <p>16F0299</p>
<p>Intermittent wiper</p>	<p>If the wiper switch is turned to INT when the ignition switch is in the ON or ACC position, the wipers move intermittently in a range of 3 – 12 second intervals according to the setting of the intermittent variable volume switch.</p>	 <p>16R0080</p> <p>16F0300</p>
<p>Mist wiper</p>	<p>If the washer switch is turned on for less than 0.6 second when the ignition switch is in the ON or ACC position, the wipers move through one cycle.</p>	 <p>16R0080</p> <p>16A0178</p>
<p>Washer linked wiper</p>	<p>If the washer switch is turned ON for 0.6 second or more when the ignition switch is in the ON or ACC position, the wipers begin to function 0.6 second after washer fluid is sprayed out, continue wiping for 2 – 3 cycles after the switch is turned OFF and then stop.</p>	 <p>16R0081</p> <p>16R0099</p>
<p>Headlamps UP/DOWN control</p>	<p>The headlamps are raised and lowered by operating the pop-up switch and lighting switch. (Refer to page 7-7 for raising and lowering the headlamps.)</p>	 <p>16F0298</p>

OPERATION

CENTRAL DOOR LOCKING

- (1) When the inside lock knob on the driver's side is locked, AND1 outputs an H signal which causes Tr2 to turn ON for 0.5 seconds by means of timer circuit I, and all of the doors lock. In addition, when the inside lock knob on the driver's side is unlocked, the L signal is reversed by the NOT1 and a H signal is input to the unlock output side of timer circuit I. This causes Tr1 to turn on for 0.5 seconds, and all of the doors unlock.
- (2) When the driver's side door is locked by means of the key, the operation is the same as in step (1).
- (3) If the passenger's side door is locked by means of the key, an H signal is input to the door lock switch

judgement circuit, and when the key cylinder switch ON signal is input, an H signal is input to the lock output side of timer circuit I. This causes Tr2 to turn ON for 0.5 seconds, and all of the doors lock. Also, if the passenger's side door is unlocked by means of the key, an L signal is input to the door lock switch judgement circuit, and when a key cylinder switch ON signal is input, an H signal is input to the unlock side of timer circuit I. This causes Tr1 to turn ON for 0.5 seconds, and all of the doors unlock.

PREVENTING DOORS FROM BEING LOCKED WHEN IGNITION KEY IS LEFT BEHIND

If the key is left in the ignition switch (key reminder switch OFF), when the driver's side door is opened (door switch ON) and the driver's side inside lock knob is locked, AND3 and AND2 output H signals.

This causes timer circuit II to operate to turn Tr1 ON, and all of the doors unlock to prevent the key from being left behind.

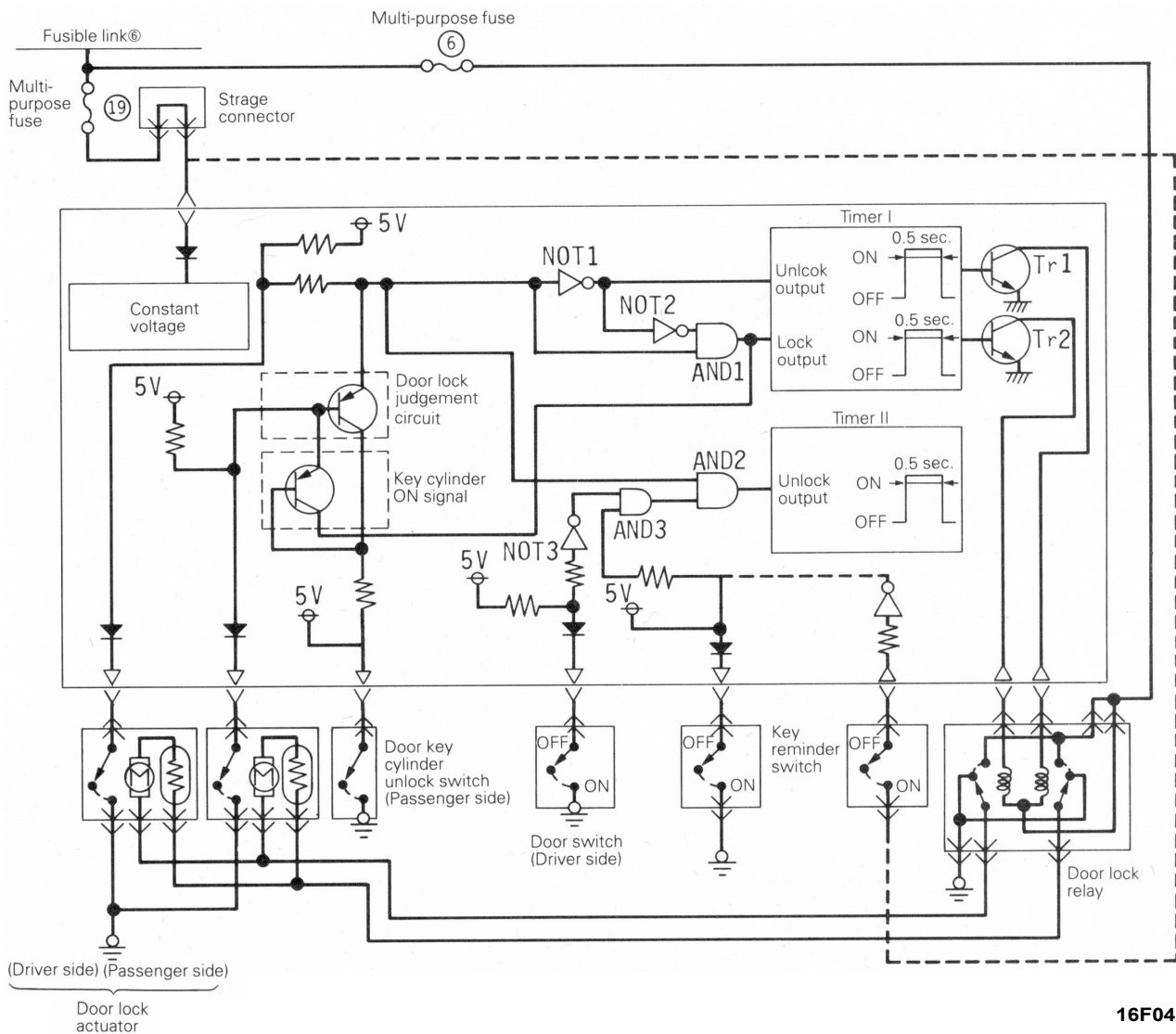

NOTE

--- indicates area of theft-alarm system.

DEFOGGER TIMER

(1) When the ignition switch is ON, if the defogger switch is turned ON, the signal input to the NOT becomes an L signal, and the converted H signal makes the timer circuit operate. Next, an H signal of the power circuit and an H signal of the timer circuit are input to the AND and the output H signal turns transistor Tr1 ON. This causes the defogger relay to operate, and current flows to the defogger.

After 11 minutes, the signal output by the timer circuit becomes an L signal, and the defogger operation is stopped.
 (2) Even if the defogger is operating, if the defogger switch is turned once more to ON, the defogger relay turns OFF and the defogger operation is stopped.

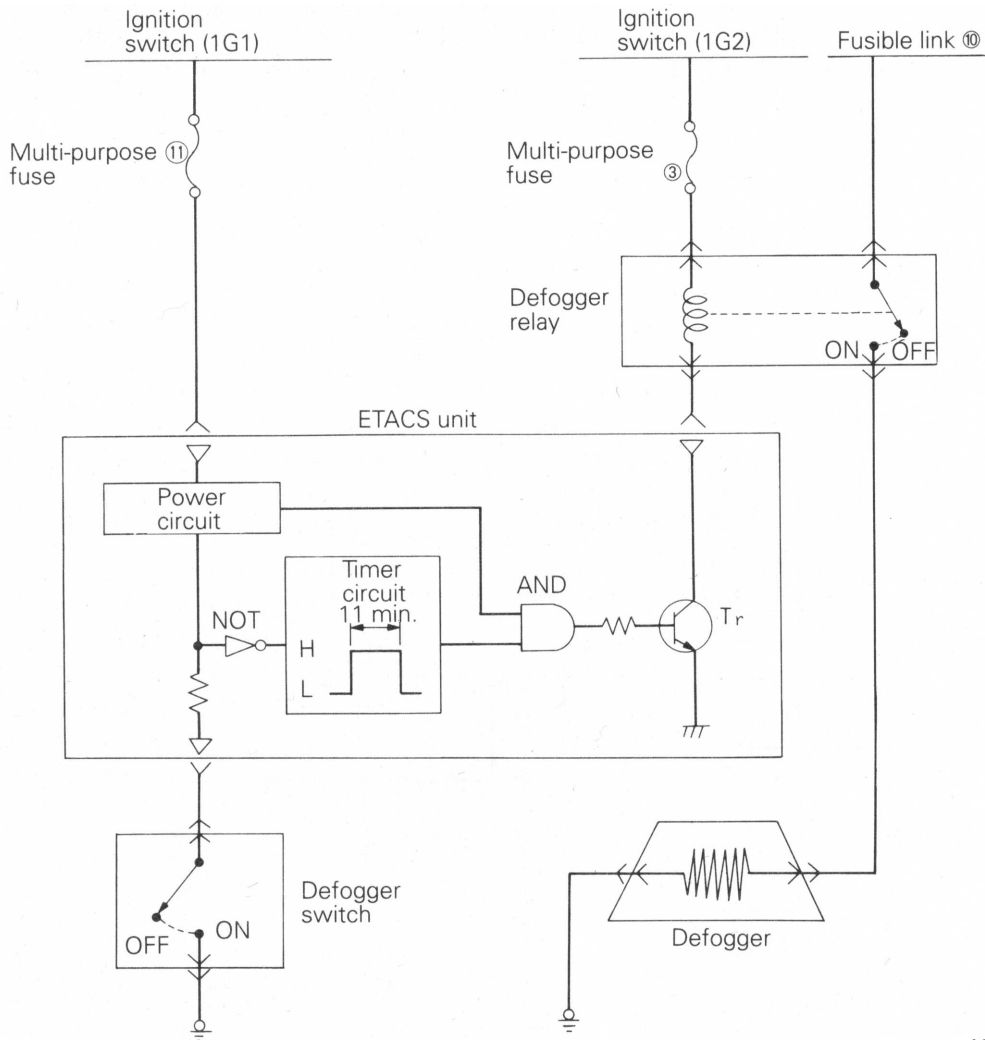

SEAT BELT TENSION REDUCER TIMER

- (1) Because an H signal is input to the OR1 when the ignition switch is turned to ON, OR2 outputs an H signal, and transistor Tr turns ON, enabling the front seat belt solenoid (tension reducer function) to operate. (For the tension reducer, refer to GROUP 6 - Seat Belt.)
- (2) When the ignition switch is turned from ON to OFF, the H signal converted by NOT1 causes timer I to output an H signal for 30 seconds. Because the H signal is input to OR 1, the front seat belt solenoid can operate in the same way as in step (1). (30 seconds)
- (3) When the ignition switch is turned from ON to OFF, an H signal is output from timer I for 30 seconds, but if the driver's side door is opened during this time, the door switch turns ON. The input side of NOT2 then becomes an L signal and the converted H signal is input to the AND. It is matched with the H signal from timer I and the output from the AND is an H signal. This causes timer II to input an H signal to OR2 for 30 seconds. This in turn causes Tr to turn ON, and the front seat belt solenoid can operate for a further 30 seconds.

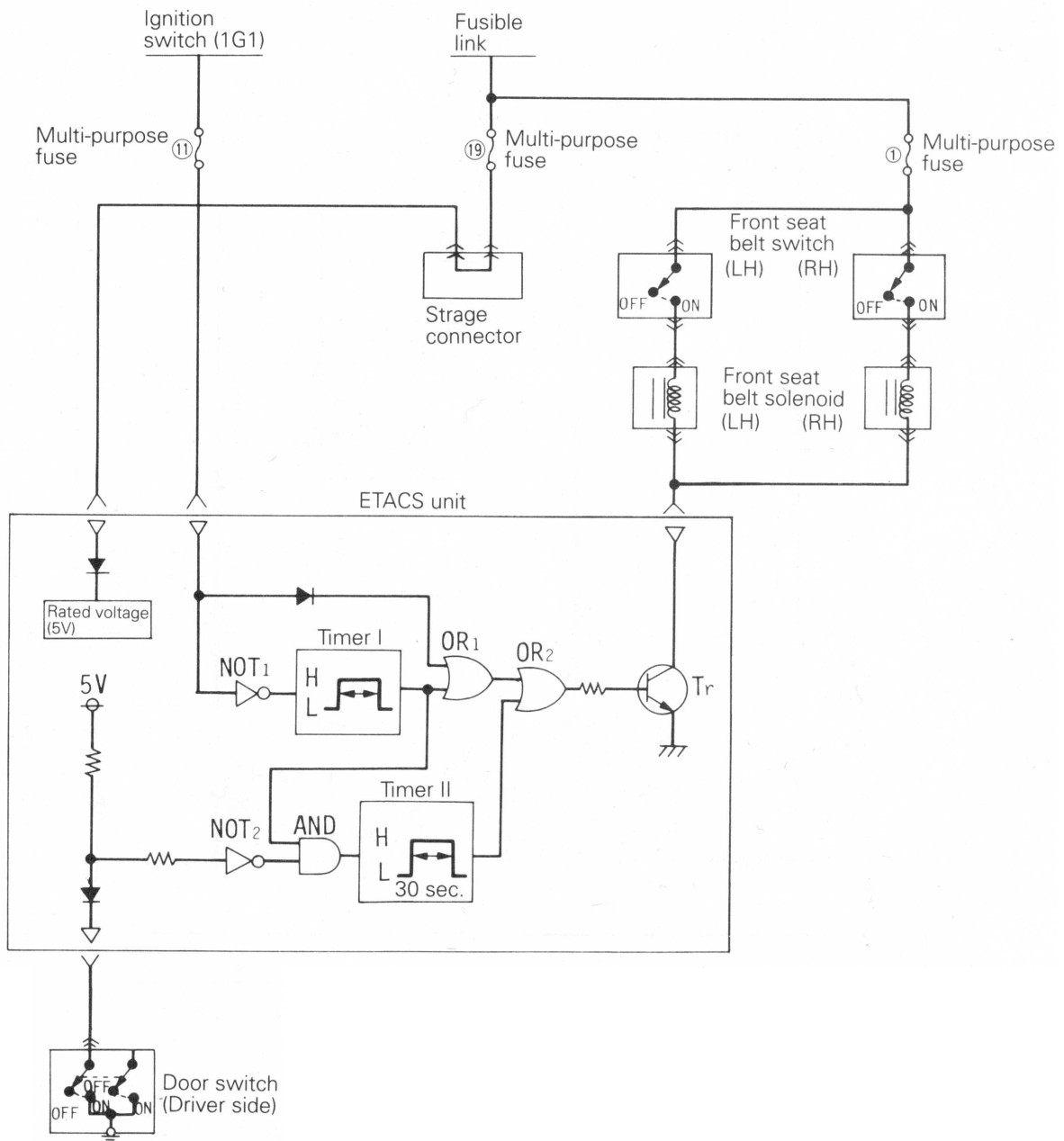

DIMMER TYPE LAMP

- (1) If the room lamp switch is the DOOR position and the door is opened (door switch ON), current from the battery flows from lamps (room lamp, 'foot lamp ignition key cylinder illumination lamp) → ETACS unit → door switch → earth and the lamp go on.
- (2) If the ignition switch is OFF, input to NOT becomes an L signal and the reversed H signal is input to AND. If a door is closed at this time (door switch OFF), the circuit of door switch → earth is cut off and, since an H signal is input to AND, AND outputs an H signal

and activates the timer circuit.

The timer circuit outputs to the Tr base a signal that gradually varies for 6 seconds due to duty control, and the voltage for the lamps is gradually reduced to dim the lamps.

- (3) If the ignition switch is turned ON, the input to NOT becomes an H signal and the reversed L signal is input to AND. As a result, even if the door is closed, the lamp does not dim but is extinguished immediately since the timer circuit is not activated.

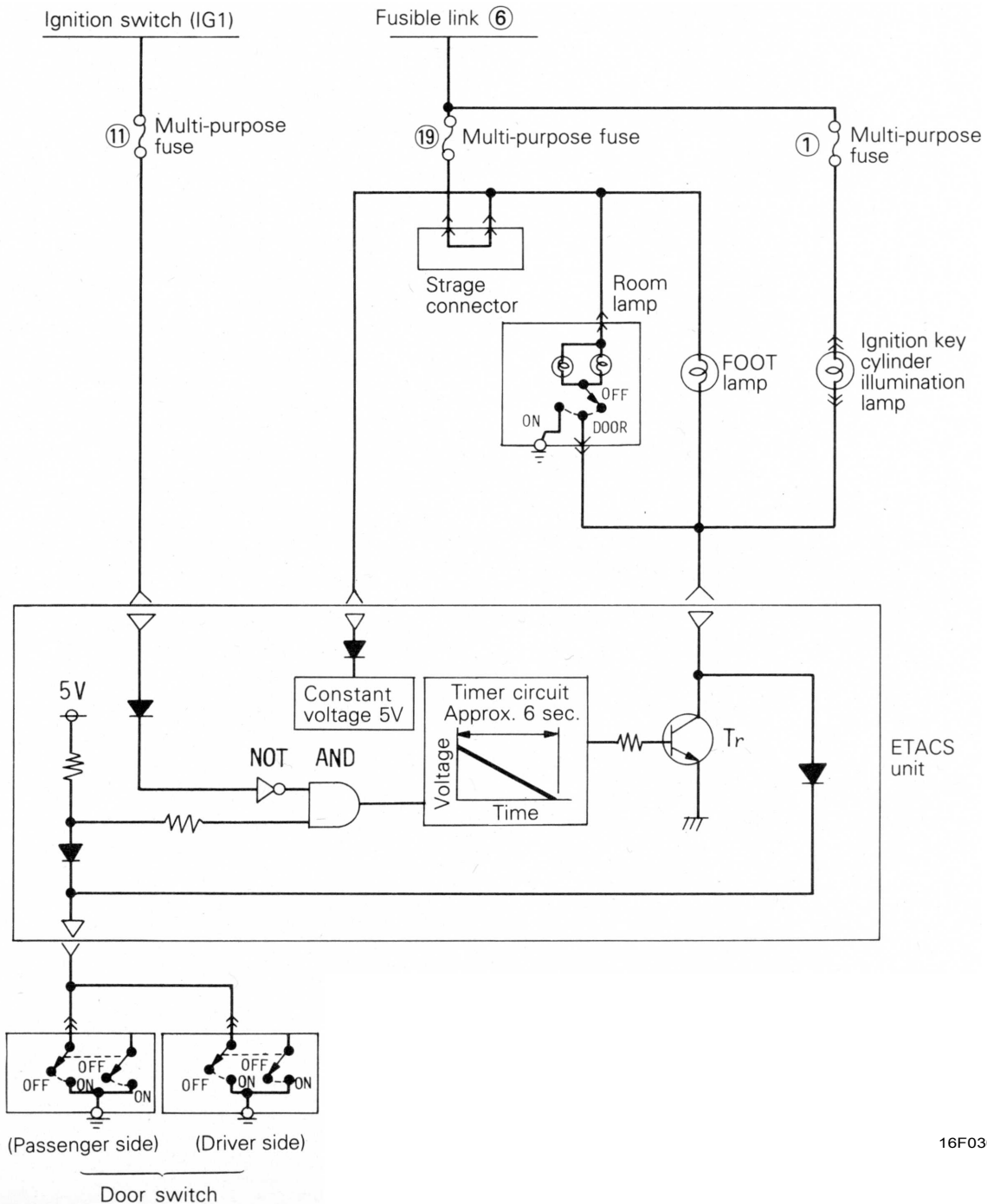

SEAT BELT WARNING LAMP

- (1) Voltage is applied from the battery via the seat belt warning lamp to the Tr collector.
- (2) When the ignition switch is turned ON, the timer circuit outputs an H signal for 6 seconds and an L signal and H signal are output alternately from the pulse circuit.
- (3) When there is output from both the timer circuit and pulse circuit to AND, Tr is turned ON. Consequently, the 6 second lamp flashes.
- (4) After flashing for 6 second, the lamp goes out.
- (5) If the ignition switch is turned OFF during the 6 seconds, the lamp goes out.
- (6) If the seat belt switch is turned OFF (seat belt buckled) during the 6 seconds, the warning lamps go out.

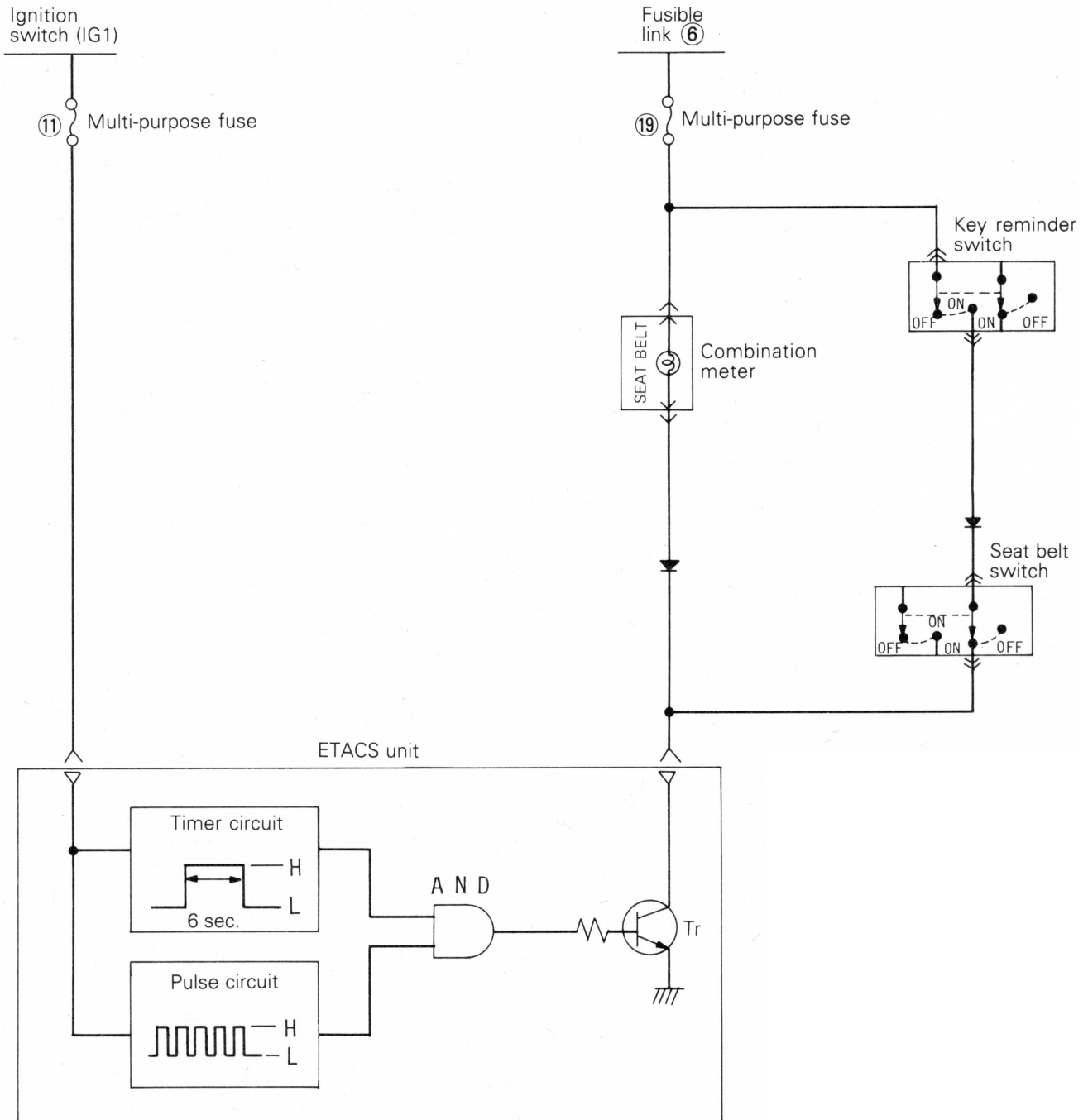

INTERMITTENT WIPER

- (1) If the wiper switch is turned to the INT position when the ignition switch is in the ON or ACC position, the voltage value from the intermittent variable volume switch is input to the intermittent time detection circuit.
- (2) The intermittent time detection circuit outputs an H signal at the intermittent time according to the set value of the intermittent variable volume switch and, via OR, turns the Tr on and off to operate the wiper.

- (washer switch On time) delay, and the Tr is turned on via OR for one wiper cycle (mist wiper).
- (2) When the washer switch ON time is 0.6 second or more, washer switch timer circuit I I is activated, there is a 0.6 second delay due to the functioning of the ON delay timer and the Tr is turned on via OR for one wiper cycle.
- (3) In addition, if the washer switch is turned OFF, the timer circuit II operates the wiper for 2-3 cycles after the washer switch is turned OFF since there is a 2.5-3.8 second delay before the output is turned off.
- (4) During intermittent operation with the wiper switch in the INT position, the mist wiper and washer linked wiper operate.

MIST WIPER AND WASHER LINKED WIPER

- (1) If the washer switch is turned on when the ignition switch is in the ON or ACC position and the wiper switch is off, an H signal is input to the washer switch ON time detection circuit and, when the washer switch ON time is less than 0.6 second, timer circuit I is activated, there is a t second

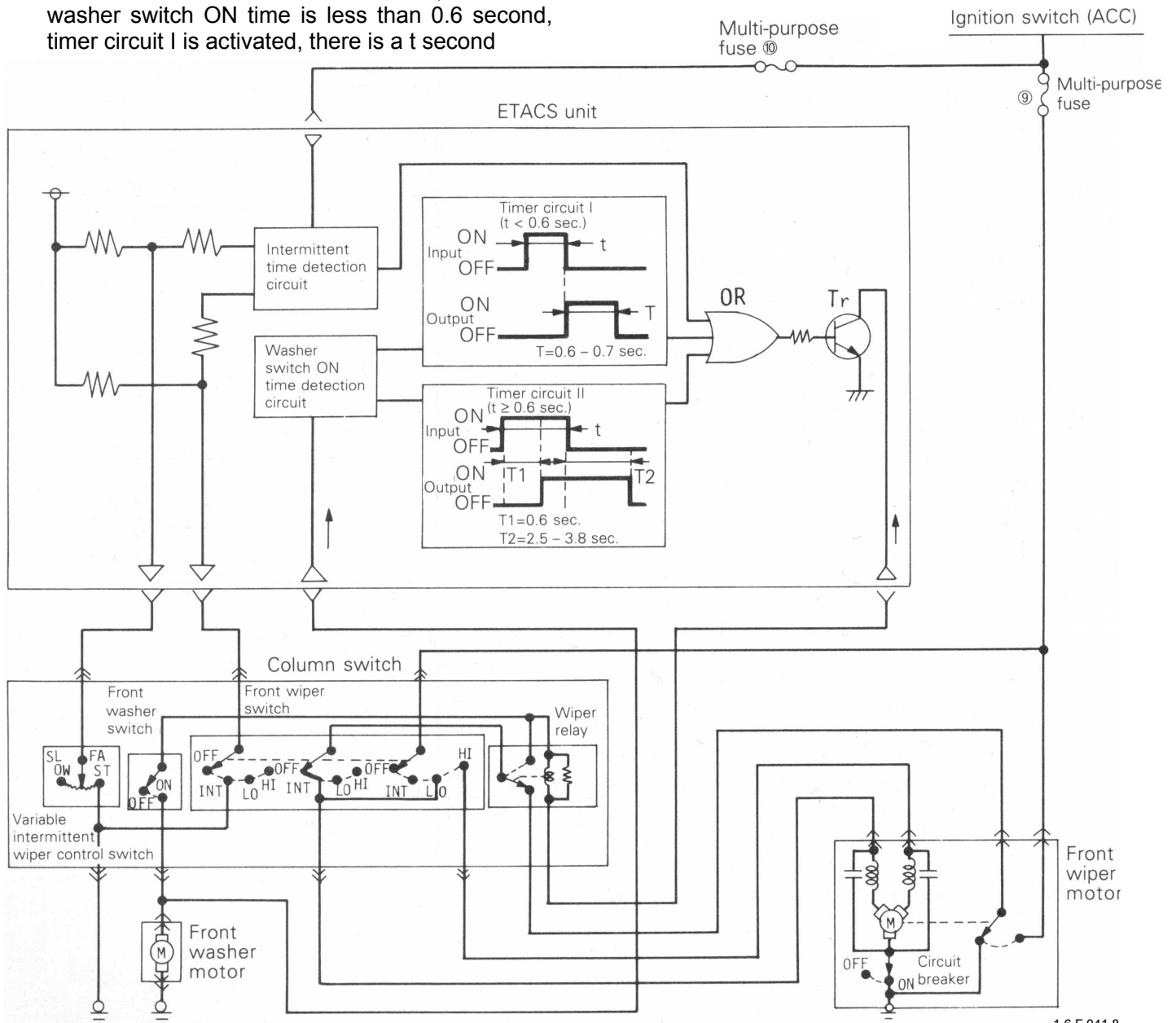

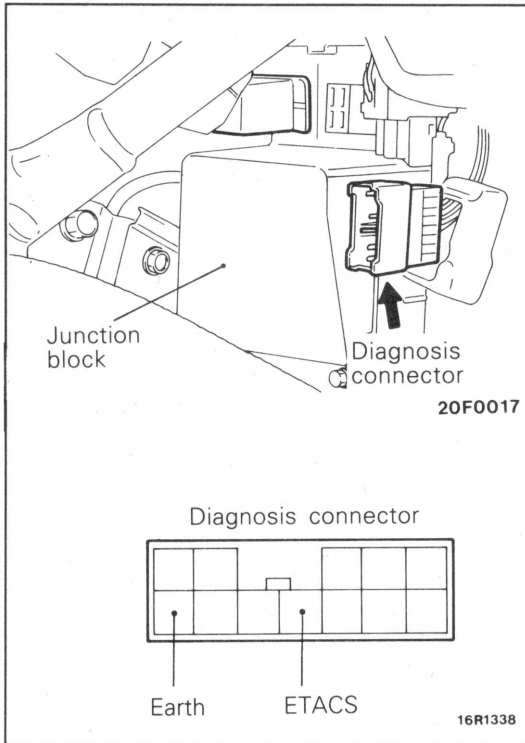

INPUT INSPECTION FUNCTIONS OF ETACS

The ETACS control unit has an input inspection function that can check everything from each switch to the ETACS control unit by using a multi-use tester to measure the voltage variations at the ETACS terminals on the diagnosis connector.

The diagnosis connector is installed on the side of the junction block on the lower left-side of the instrument panel.

The ETACS input inspection function has the following functions.

- (1) Ignition switch (ACC and ON)
- (2) Wiper switch (I NT)
- (3) Variable intermittent wiper control switch
- (4) Washer switch
- (5) Key reminder switch
- (6) Door switch
- (7) Door lock switch
- (8) Defogger switch
- (9) Pop-up switch

PARTS AND FUNCTIONS RELATED WITH ETACS

Components		Functions		Prevention of door lock when key is left ignition	Defogger timer	Seat belt tension reducer timer	Dimming lamp	Seat belt warning lamp	Intermittent	Mist wiper	Washer linked wiper	Headlamps UP/DOWN control	
Input side	Ignition switch	ACC*							<input type="radio"/>	<input type="radio"/>	<input type="radio"/>		
		ON*	1G1			<input type="radio"/>	<input type="radio"/>	<input type="radio"/>	<input type="radio"/>	<input type="radio"/>	<input type="radio"/>	<input type="radio"/>	
			1G2			<input type="radio"/>							
	Key reminder switch*				<input type="radio"/>			<input type="radio"/>					
	Column switch	Wiper switch (INT)*								<input type="radio"/>			
		Variable intermittent wiper control switch*								<input type="radio"/>			
		Washer switch*									<input type="radio"/>	<input type="radio"/>	
		Lighting switch											<input type="radio"/>
	Door switch*				<input type="radio"/>		<input type="radio"/>	<input type="radio"/>					
	Door lock actuator*				<input type="radio"/>								
	Defogger switch*					<input type="radio"/>							
	Pop-up switch*												<input type="radio"/>
	Seat belt switch	Driver seat					<input type="radio"/>		<input type="radio"/>				
		Passenger seat					<input type="radio"/>						
Output side	Wiper relay								<input type="radio"/>	<input type="radio"/>	<input type="radio"/>		
	Room lamp, foot lamp, ignition key cylinder illumination lamp						<input type="radio"/>						
	Door lock power relay				<input type="radio"/>								
	Seat belt solenoid					<input type="radio"/>							
	Seat belt warning lamp							<input type="radio"/>					
	Pop-up motor relay											<input type="radio"/>	
	Defogger relay					<input type="radio"/>							

NOTE

(1) *mark indicates a switch or sensor that can be used for input inspection with the multi-use tester.

(2) mark indicates a part relevant for each function.

THEFT-ALARM SYSTEM

When the theft-alarm system has been armed by a fixed sequence for locking the doors without the key, if thereafter a door, the tailgate or the hood is opened in an unauthorized way, the horn will sound intermittently for a period of 30 seconds, thus providing audible warning signals.

Furthermore, the starter circuit is interrupted in such a way that the engine cannot be started, if the ignition key is not used.

Note that this system is controlled by the Electronic Control Unit (ECU) as one function of the ETACS (Electronic Time and Alarm Control System).

The system is composed of the components described below.

NOTE

The "ECU" (Electronic Control Unit) indicates the ETACS control unit.

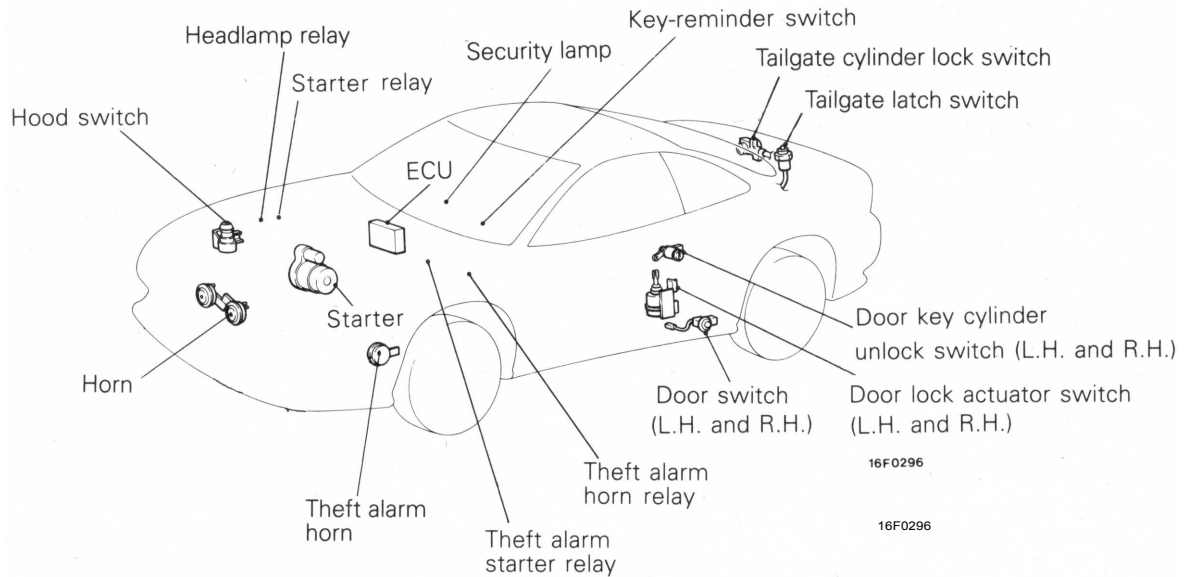

OPERATION

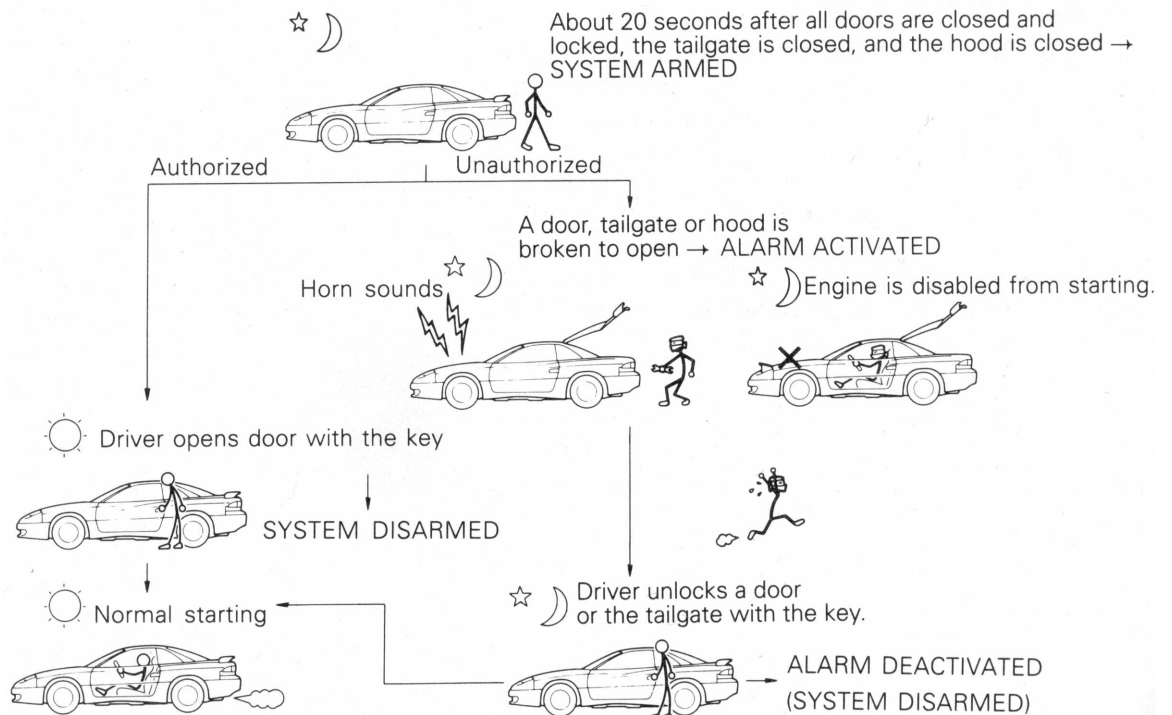

ARMING THE SYSTEM

After the following procedures have been completed, the SECURITY lamp illuminates for about 20 seconds, and when illumination stops, the system is armed.

- (1) Pullout the ignition key from the key cylinder.
- (2) Open a door. (The other door is locked.)
- (3) Lock the door with the key or the keyless-locking method.
(The central door locking system will then function to lock all doors.)

NOTE

- (1) The system is set regardless of whether the hood and tailgate are open or closed, and is armed as soon as the lamp goes out.
- (2) While the timer is functioning (approximately 20 sec.), it is not reset even if the hood or tailgate is opened and closed.

DISARMING THE SYSTEM

The system will be disarmed,

- (1) If the key is used to unlock a door.
- (2) If the system is armed while the driver is still in the vehicle, the system can be disarmed by inserting the ignition key and turning it to the ACC or ON position.
- (3) If the door is unlocked while closing the door or the door is ajar.
- (4) If the door is unfastened while the SECURITY lamp illuminates.
- (5) If, after the keyless warning is set, the door on the driver's side or passenger's side is locked but not completely closed (door-ajar).

ACTIVATING THE ALARM

- (1) If an attempt is made to open a door, the tailgate or hood, without using the key, while the system is armed, the horn will sound intermittently for approximately 30 sec.
Furthermore, the starter circuit is interrupted at this time also, making starting of the engine impossible.
- (2) If a further attempt at forcible entry is made after the first 30 sec. alarm has finished, the 30 sec. alarm will be activated again.

DEACTIVATING THE ALARM

- (1) To deactivate the alarm, insert the key into the door's key cylinder and turn the key.
- (2) The alarm is deactivated and the system is disarmed when the tailgate is unlocked with the key.

CHECKING THE SYSTEM OPERATION

The activation/operation of the system can be checked by following the steps below.

- (1) Turn the ignition key to the ON position and then use the power-window switch to fully open the window on the driver's side.
- (2) Turn the ignition key to the LOCK position and then remove the key from the ignition.
- (3) Open only the driver's door, and close all the other doors, as well as the hood and the tailgate.
- (4) Lock the driver's door with the key or the keyless-locking method.
- (5) All doors will then be locked, and the SECURITY lamp (within the combination meter) will illuminate; check to be sure that illumination stops in about 20 seconds.
- (6) After about two seconds have passed after the SECURITY lamp illumination stopped, reach through the window of the driver's door, pull up the lock lever to unlock the door, and then open the door.
- (7) Check to be sure that, when the door is opened, the horn starts sounding.
- (8) To stop the alarm, insert the key into the door's key cylinder and turn the key.

NOTE

To check the alarm for the opening of the tailgate or hood, open the tailgate (or the hood) by using the remote tailgate release lever (or the hood release lever), located on the driver's side either before the alarm is activated by the opening of a door, or after the finish of the first 30 sec. alarm.

HEATER AND AIR CONDITIONING

GENERAL INFORMATION

The heater and air conditioning have outstanding cooling and heating performance and use a small amount refrigerant system.

FEATURES

Improvement of visual recognition	Adoption of air conditioner colour monitor
Improvement of reliability and serviceability	<ol style="list-style-type: none"> 1. Adoption of a 2-step control system for the condenser and radiator fan speed. 2. Flange fitting of the receiver piping joints. 3. Belt protection by belt lock controller when compressor is locked.
Improvement of performance	<ol style="list-style-type: none"> 1. Adoption of multi-flow type condenser. 2. Adoption of small amount refrigerant system. 3. Adoption of heater unit with maximum cool by-pass.
Improvement in performance	<ol style="list-style-type: none"> 1. Adoption of a multi-flow type condenser. 2. Adoption of a small amount refrigeration system.

SPECIFICATIONS

Items	Specifications
Heater unit	
Type	Three-way-flow full-air-mix system
Heater control switch	Push button type
Compressor	
Model	Scroll type (FX-105VS)
Refrigerant unit lubricant	cm ³ (cu.in.) FREOL S-83 or SUNISO 5GS 160 +20 / -0 (9.8 +1.2 / -0)
V-belt size	mm (in.) 1,150 (45.3)
Condenser	
Type	Multi-flow type
Dual-pressure switch	
High pressure switch	kPa (kg cm ² , psi) OFF: 2,700 (27, 384) ON: 2,100 (21, 299)
Low pressure switch	kPa (kg cm ² , psi) OFF: 210 (2.1,30) ON: 235 (2.35, 33)
Freezer prevention	°C (°F) Fin temperature thermostat
	OFF: -2 (28.4) ON: 2 (35.6)
Refrigerant and quantity	g (oz) R-12 MAX 770-870 (27-31)

COMPONENTS

<AIR CONDITIONER>

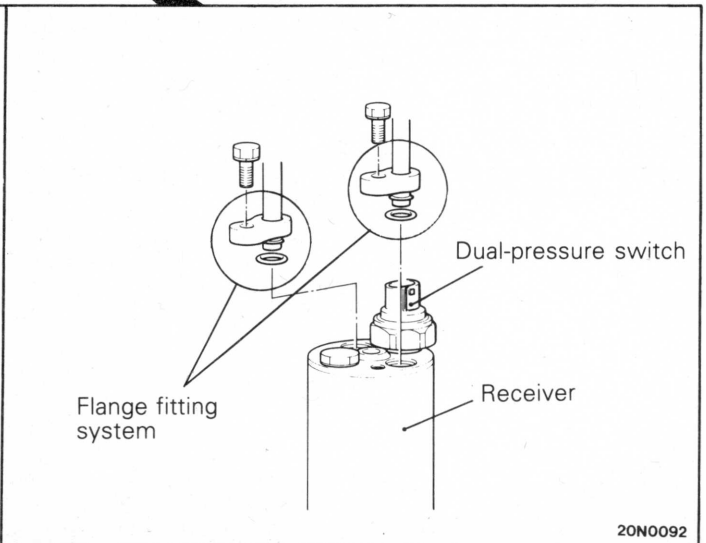
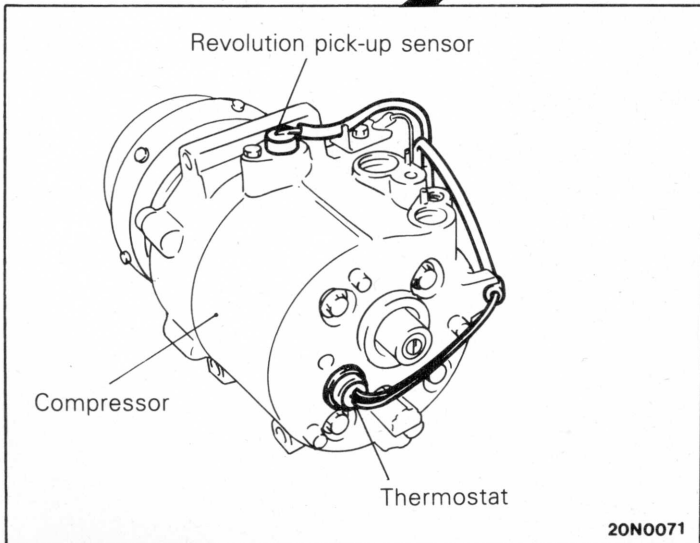
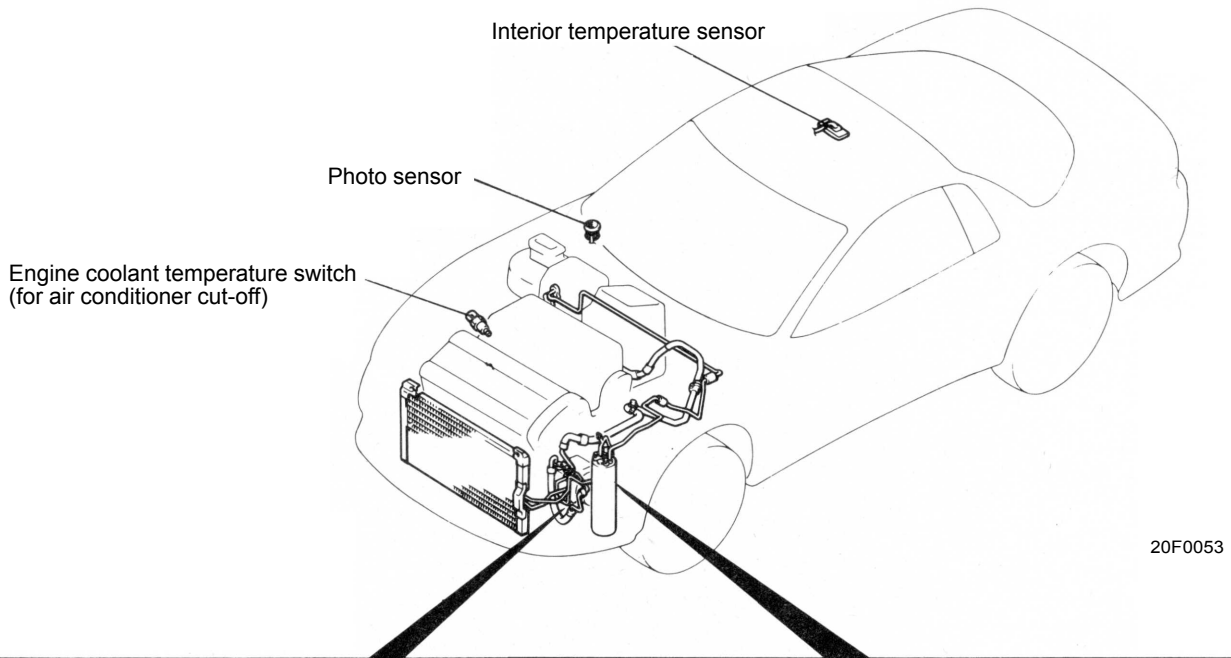
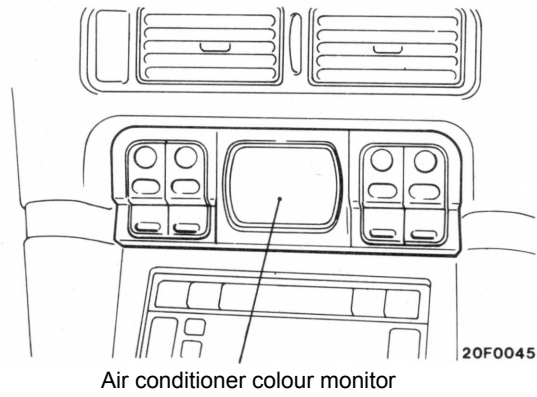

<HEATER>

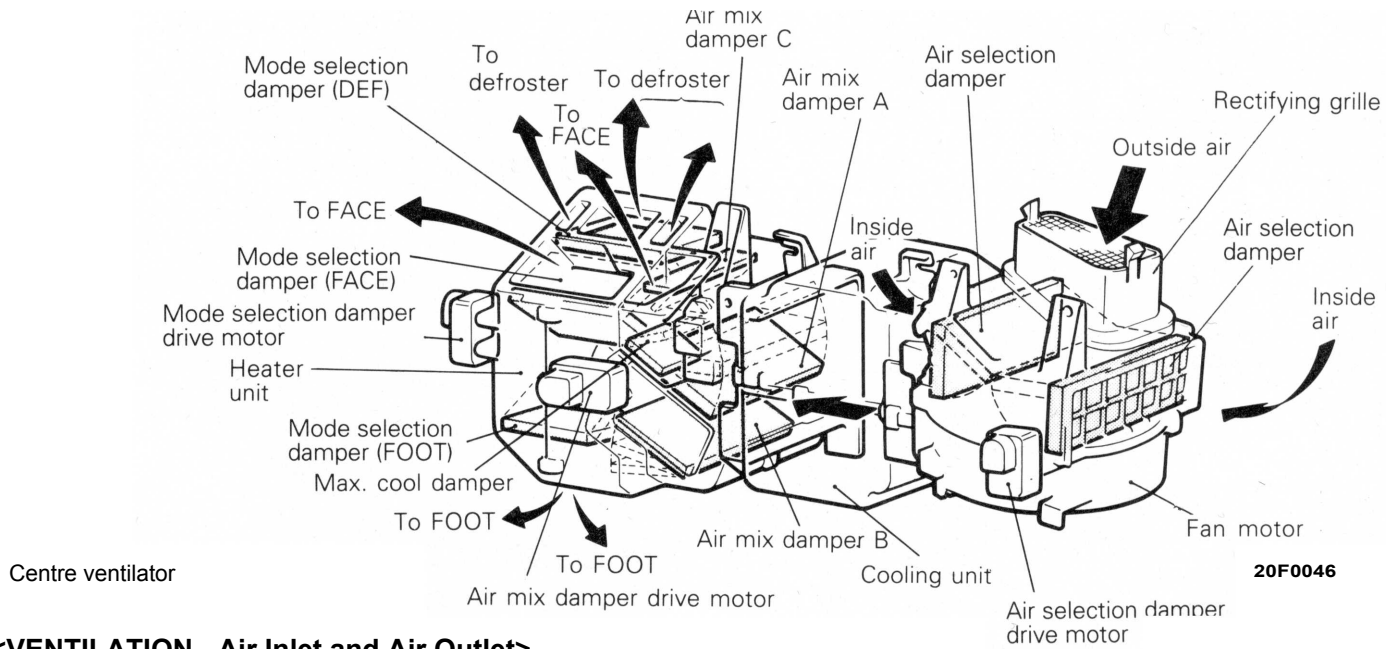
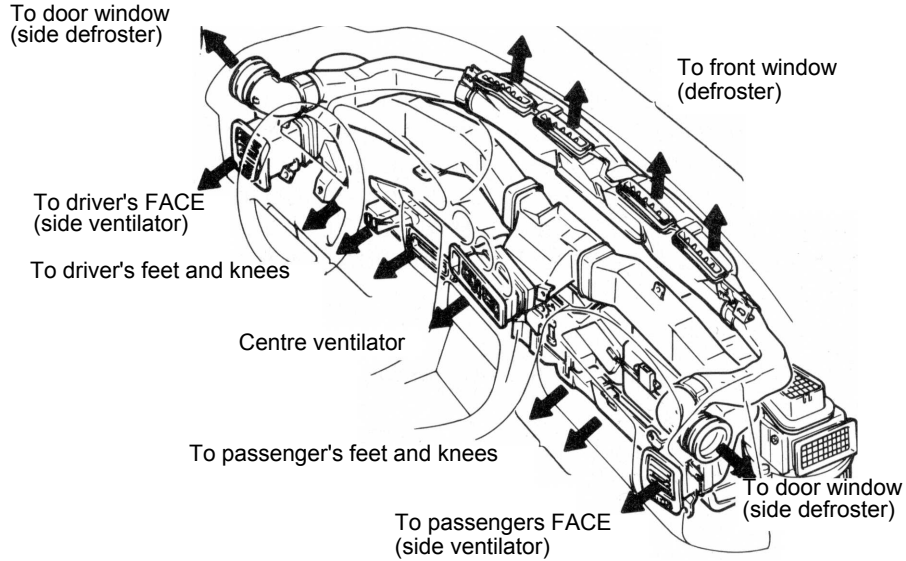

<VENTILATION - Air Inlet and Air Outlet>

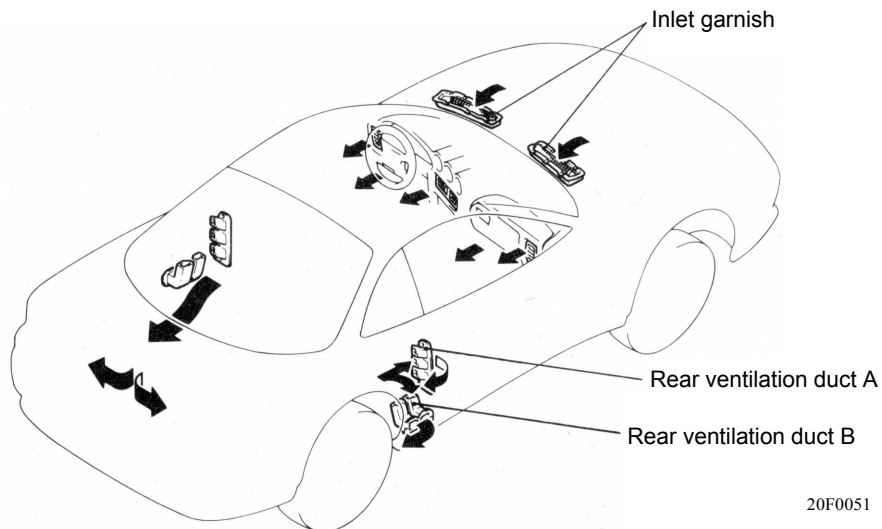

SMALL AMOUNT REFRIGERANT SYSTEM

From July 1989, the consumption and production of specially designated chlorofluorocarbon have been regulated world-wide to protect the ozone layer. Chlorofluorocarbon R-12, used as the Refrigerant in automobile air conditioners, is the object of those regulations and there is a need to control the amount of

chlorofluorocarbon used as much as possible. The small amount refrigerant system has been developed to improve the performance of the structural parts of the air conditioner in accord with those regulations, to make them more compact, etc.

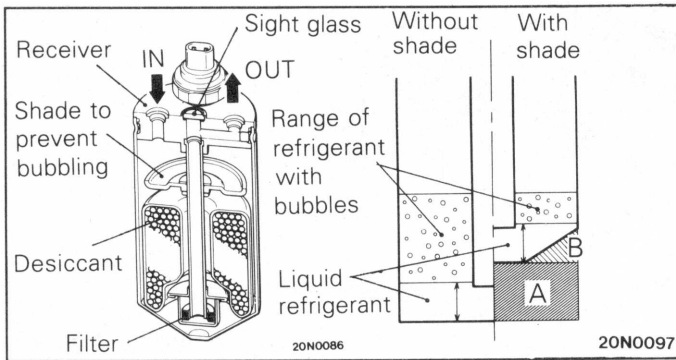

RECEIVER

A receiver with a shade to prevent bubbling is used. Bubbling inside the receiver can be controlled with the shade. Consequently, as shown in the figure, the range of liquid refrigerant mixed in the bubbles can be reduced. As a result, the amount of refrigerant can be reduced (Figure on the left (A)).

Furthermore, the amount of refrigerant is further reduced by making the bottom of the receiver into a cone shape (Figure on the left (B)).

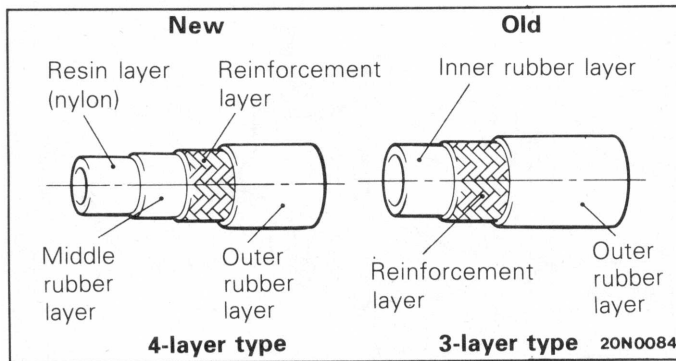

REFRIGERANT LINE

The 3-layer type hose that was used up to now was replaced by a 4-layer type hose in order to reduce the amount of refrigerant permeated into the refrigerant line rubber hose.

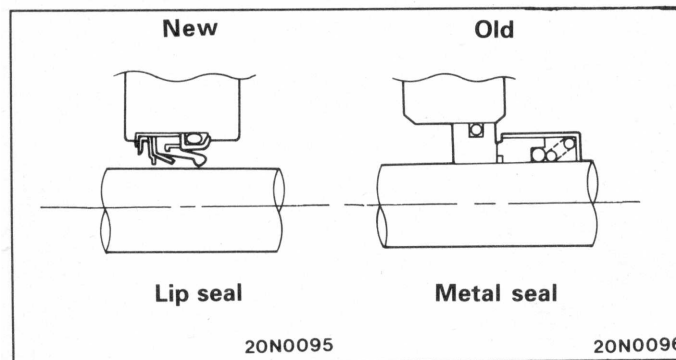

AIR CONDITIONER COMPRESSOR

Leakage of refrigerant from bearings has been reduced by changing the air conditioner bearings from metal seal to lip seal type.

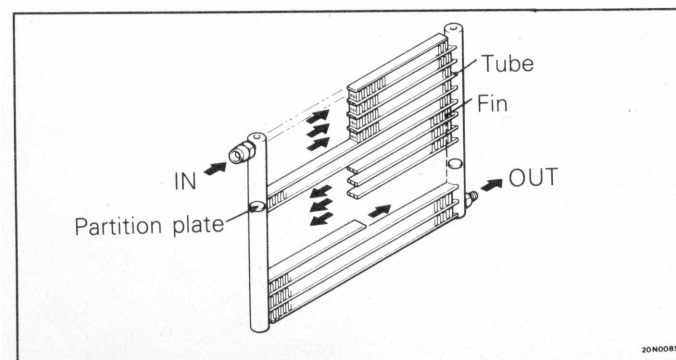

CONDENSER

By adopting a multi-flow type condenser, not only heat exchange performance has been improved, but also the condenser has become more compact.

HEATER UNIT

The heater unit is a 3-layer flow type full air mix heater with outstanding heating characteristics. There is a by-pass passage to increase the amount of air at maximum cooling. The by-pass passage is opened by the max-cool damper which is connected to the air mix damper and, consequently, some of the air is blown

directly to the air outlet (FACE). As a result, noise is reduced by reducing air flow resistance inside the heater and by controlling the generation of air turbulence inside the heater.

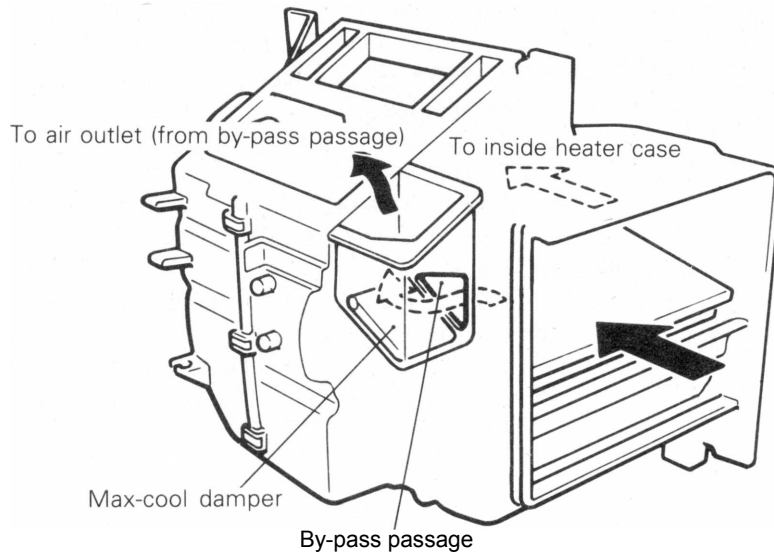

20F0047

AIR CONDITIONER CONTROL PANEL

There is an air conditioner colour monitor in the air conditioner control panel of the full automatic air conditioner. The air conditioner colour monitor is a dynamic

display in which the display arrow moves after the mode button is operated.

Air conditioner colour monitor

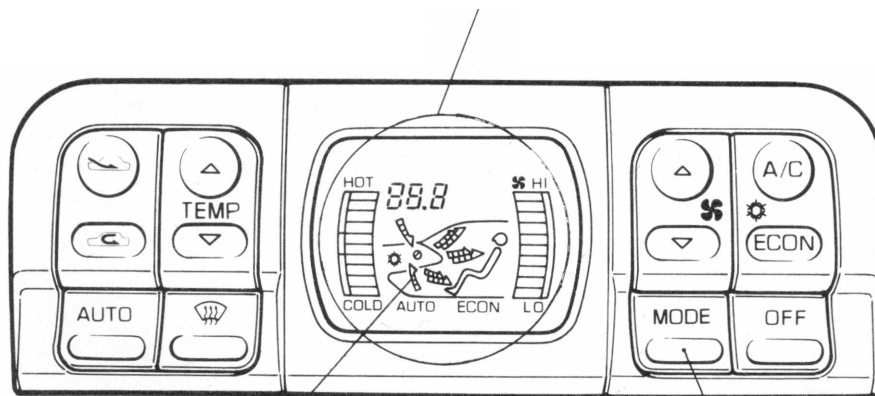

Display arrow

Mode button

20F0084

COMPRESSOR CONTROL

If anyone of the following switches and sensors is turned off, the magnet clutch of the compressor is turned off.

Switch and sensor	Operating condition of compressor
Blower switch Air conditioner switch	} Automatic when in AUTO
Dual-pressure switch High pressure switch kPa (kg cm ² , psi) Low pressure switch kPa (kg cm ² , psi)	OFF: 2,700 (27, 384) or more ON : 2,100 (21, 299) or less OFF: 210 (2.1, 30) or less ON : 235 (23.5, 33) or more
Engine coolant temperature switch	OFF at 115 ± 3°C (239 ± 5°F) or over, ON at 108°C (226°F) or less
Engine coolant temperature sensor	OFF at 155 ± 5°C (311 ± 9°F) or over, ON at 110°C (230°F) or less
Air inlet sensor	OFF when sensing temperature is lower than a set temperature, ON when sensing temperature is higher than a set temperature (ECONO mode only)
Air thermo sensor	OFF at -2°C (28.4°F) or less, ON at 2°C (35.6°F) or over
Revolution pick-up sensor	OFF when compressor slipping rate(s) is 70% or more $S = 1 - \frac{Nc}{Ne \times \text{Pulley ratio}} \times 100$ Ne: engine rpm Nc: compressor rpm

Control when Compressor Locks

Since the compressor and alternator are driven by the same belt, the electric generating function of the alternator also stops when the belt is broken. In order to assure the electric generating function of the alternator, there is a belt lock controller to prevent breaking of the belt due to slipping when the compressor locks.

The controller makes a comparative calculation of the compressor revolutions and the engine revolutions which are detected by the revolution pick-up sensor. When

70% or more slip ratio continues for 3 seconds or more, the compressor relay goes from on to off; at the same time, in models with full automatic air conditioners, the  in the air conditioner color monitor in the air conditioner control panel blinks to announce (an abnormality and, in models with manual air conditioners, the operation display in the air conditioner switch blinks to announce an abnormality).

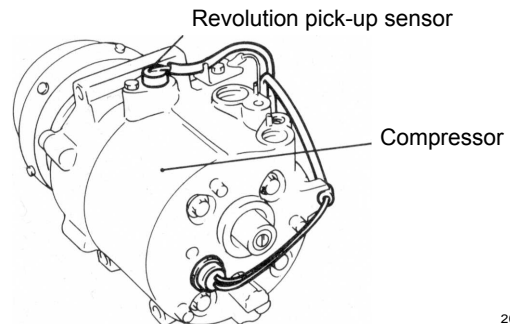
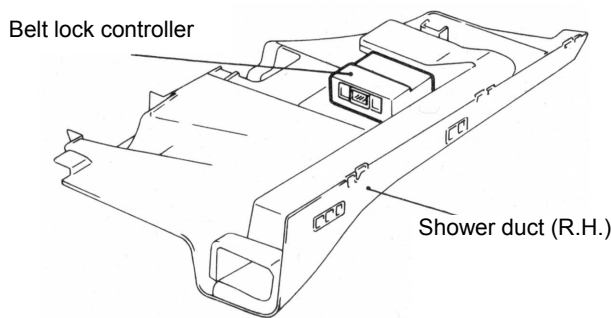

20N0071

Air conditioning color monitor

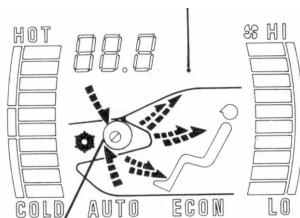

Blinking

20F0026

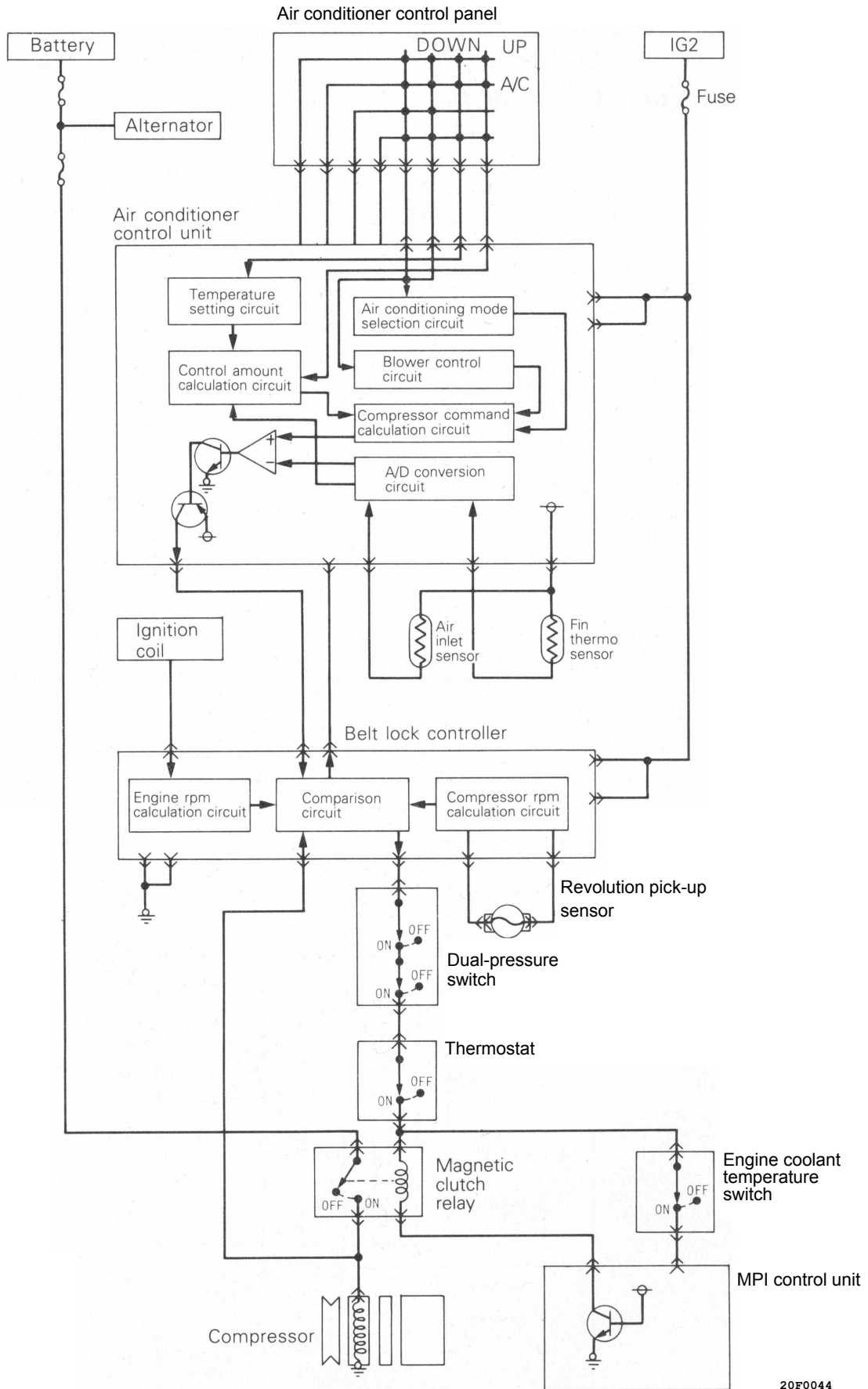

CONDENSER FAN AND RADIATOR FAN CONTROL

The rotational speed of the condenser fan and radiator fan is controlled by the engine coolant temperature and

is designed to improve cooling efficiency and to reduce fan noise.

FAN REVOLVING OPERATION MODE

Switch condition				Fan revolving operation condition	
Air conditioner switch	Thermo sensor (For radiator fan)	Thermo sensor (For condenser fan)	Engine coolant temperature switch (for air conditioner cut-off) OFF at 115 ± 3°C (239 ± 5°F) or over, ON at 108°C (226°F) or less	Radiator fan motor	Condenser fan motor Condenser fan motor operates in HIGH only when it receives input from condenser fan motor relay (HI) and (LO).
	OFF	ON at 85 ± 4°C (185 ± 7°F) or more OFF at 77°C (171°F) or less			
ON	OFF	OFF	ON	LOW	LOW
	ON	OFF		LOW	LOW
	OFF	ON	OFF	HIGH	HIGH
	ON	ON		HIGH	LOW

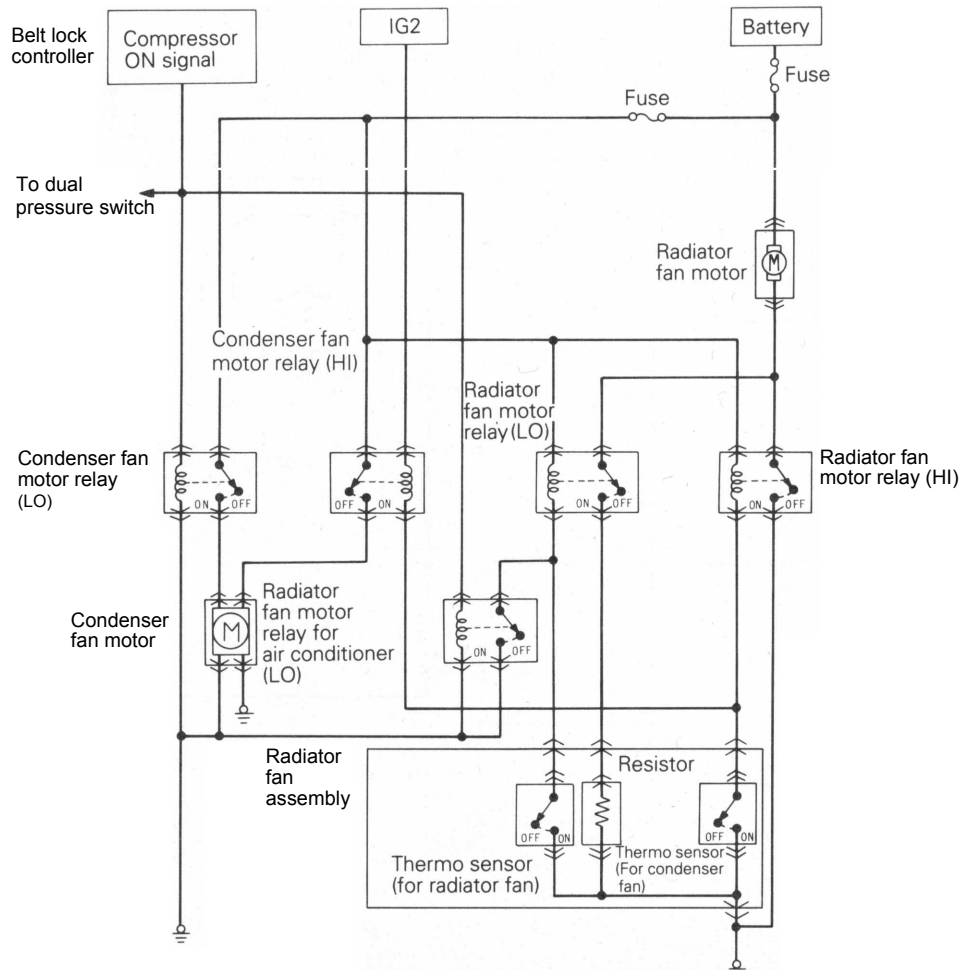

REFRIGERANT LINE

The receiver piping joints have flange fittings and the pipe ends are flared (pipe expanded) to prevent the

O-ring from dropping out and to improve workability.

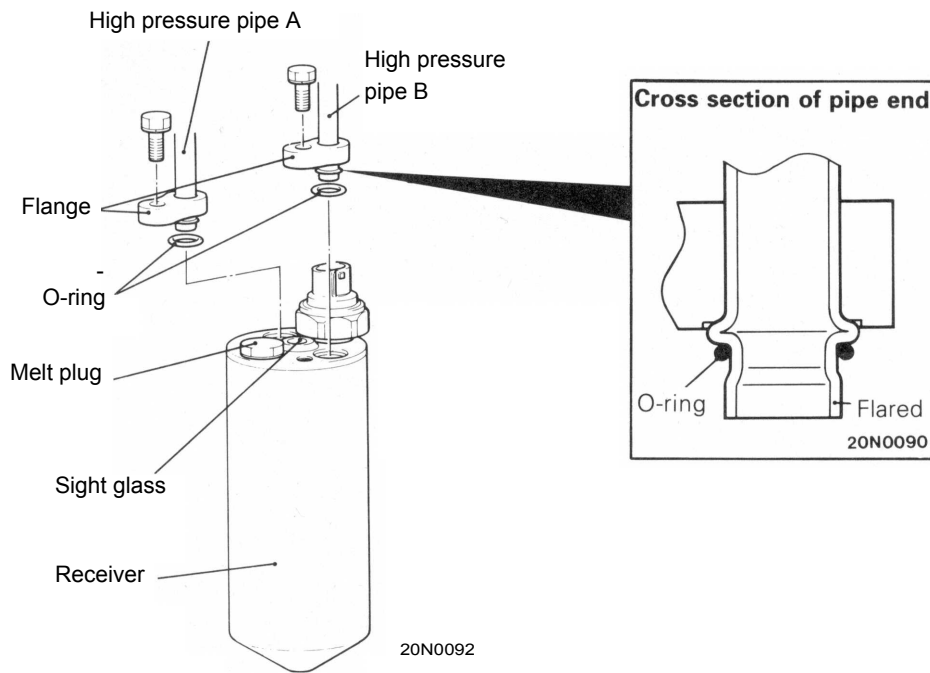

SELF-DIAGNOSIS AND BACK-UP FUNCTION

- (1) It has a self-diagnosis function to diagnose trouble in the 11 systems of sensors, etc. and in the control unit itself and helps assure easy troubleshooting.
- (2) When some abnormality is detected in the system, it outputs the location of the abnormality to the diagnosis connector in the side of the fuse box. Use the Multi-use Tester.
- (3) It not only displays the code No. but there is also a back-up safe function to stop trouble to the system due to a breakdown.
- (4) If there are 2 or more abnormalities, the code Nos. starting with the smallest are continuously displayed. Furthermore, the code No. is kept in memory until battery terminal is disconnected.

SELF-DIAGNOSIS

Code	Trouble	Back-up function or vehicle condition
0	(Normal)	(Normal)
11	Wire in interior temperature sensor broken	Reaches condition when 25°C (77°F) is detected
12	Wire in interior temperature sensor short-circuited	
13	Wire of air inlet sensor broken	
14	Wire of air inlet sensor short-circuited	Reaches condition when 20°C (68°F) is detected.
21	Wire of air thermo sensor broken	Reaches condition when -2°C (28°F) is detected.
22	Wire of air thermo sensor short-circuited	
31	Wire of air mix damper potentiometer broken or short circuited	Reaches MAX. HOT (MAX. COOL when set to MAX. COOL)
32	Wire of mode selection damper potentiometer broken or short-circuited	Reaches DEF. (FACE when set to FACE)
41	Trouble in air mix damper drive system	
42	Trouble in mode selection damper drive system	

NOTES

This page intentionally left blank.

Pub. No. PYUE9201
ENGLISH