



Honda 2005 CBR600RR

1. GENERAL INFORMATION

SERVICE RULES	1-2	REAR WHEEL/SUSPENSION SPECIFICATIONS.....	1-9
MODEL IDENTIFICATION.....	1-2	HYDRAULIC BRAKE SPECIFICATIONS.....	1-10
GENERAL SPECIFICATIONS.....	1-4	BATTERY/CHARGING SYSTEM SPECIFICATIONS.....	1-10
LUBRICATION SYSTEM SPECIFICATIONS .	1-6	IGNITION SYSTEM SPECIFICATIONS	1-10
FUEL SYSTEM (Programmed Fuel Injection) SPECIFICATIONS.....	1-6	ELECTRIC STARTER SPECIFICATIONS	1-10
COOLING SYSTEM SPECIFICATIONS	1-6	LIGHTS/METERS/SWITCHES SPECIFICATIONS.....	1-11
CYLINDER HEAD/VALVES SPECIFICATIONS.....	1-7	STANDARD TORQUE VALUES	1-12
CLUTCH/STARTER CLUTCH/GEARSHIFT LINKAGE SPECIFICATIONS.....	1-7	ENGINE & FRAME TORQUE VALUES	1-12
CRANKCASE/TRANSMISSION SPECIFICATIONS.....	1-8	LUBRICATION & SEAL POINTS	1-19
CRANKSHAFT/PISTON/CYLINDER SPECIFICATIONS.....	1-8	CABLE & HARNESS ROUTING	1-22
FRONT WHEEL/SUSPENSION/STEERING SPECIFICATIONS.....	1-9	EMISSION CONTROL SYSTEMS	1-36
		EMISSION CONTROL INFORMATION LABELS (U.S.A. only).....	1-39

GENERAL INFORMATION

SERVICE RULES

1. Use genuine Honda or Honda-recommended parts and lubricants or their equivalents. Parts that don't meet Honda's design specifications may cause damage to the motorcycle.
2. Use the special tools designed for this product to avoid damage and incorrect assembly.
3. Use only metric tools when servicing the motorcycle. Metric bolts, nuts and screws are not interchangeable with English fasteners.
4. Install new gaskets, O-rings, cotter pins, and lock plates when reassembling.
5. When tightening bolts or nuts, begin with the larger diameter or inner bolt first. Then tighten to the specified torque diagonally in incremental steps unless a particular sequence is specified.
6. Clean parts in cleaning solvent upon disassembly. Lubricate any sliding surfaces before reassembly.
7. After reassembly, check all parts for proper installation and operation.
8. Route all electrical wires as shown in the Cable and Harness Routing (page 1-22).

MODEL IDENTIFICATION

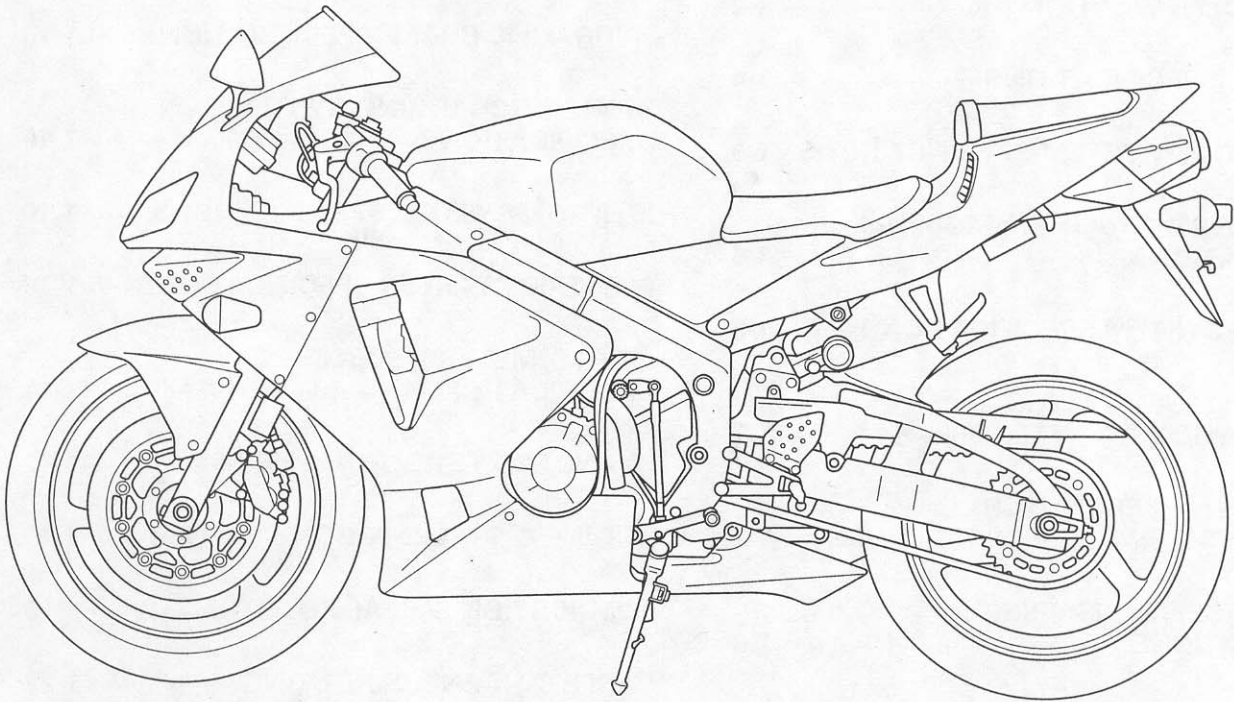

GENERAL INFORMATION

The frame serial number is stamped on the right side of the steering head.

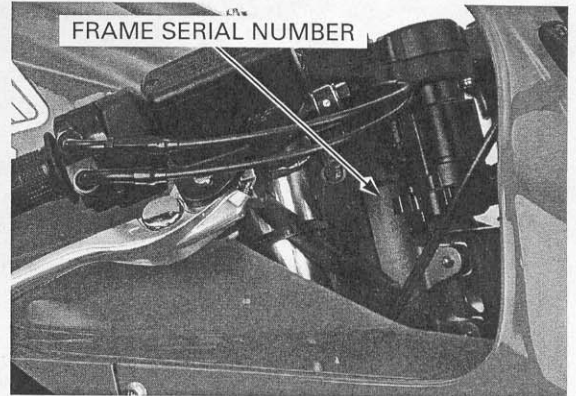

The engine serial number is stamped on the lower side of the lower crankcase.

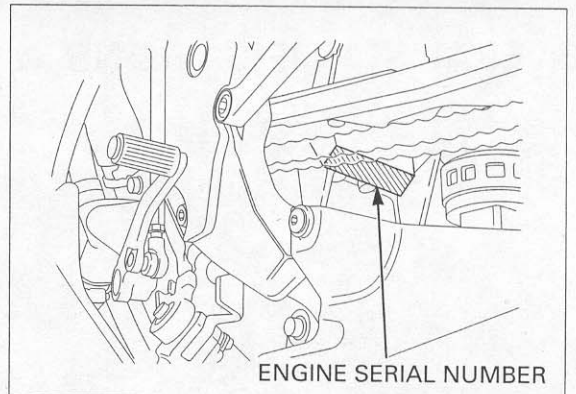

The throttle body identification number is stamped on the intake side of the throttle body as shown.

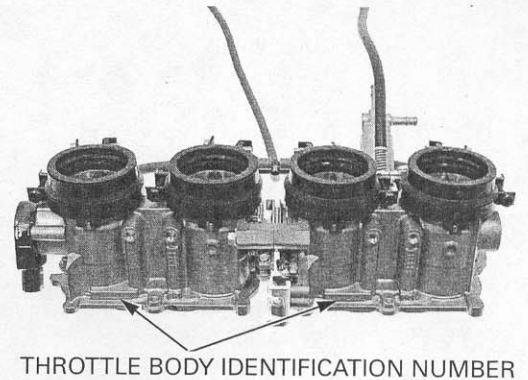

The color label is attached as shown. When ordering color-coded parts, always specify the designated color code.

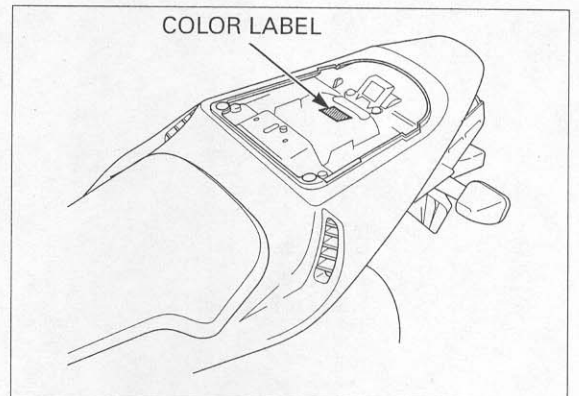

GENERAL INFORMATION

The Vehicle Identification Number (VIN) is located on left side of the main frame on the Safety Certification Labels.

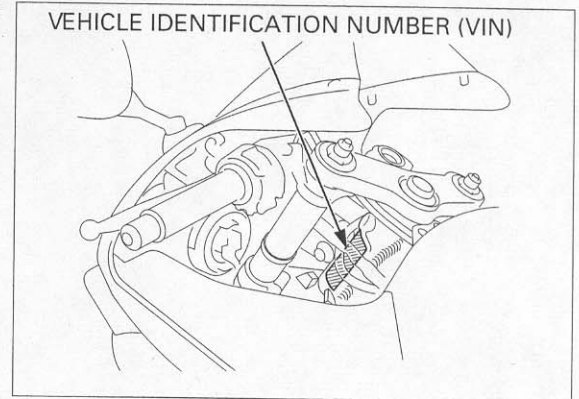

GENERAL SPECIFICATIONS

	ITEM	SPECIFICATIONS
DIMENSIONS	Overall length	2,030 mm (79.9 in)
	Overall width	695 mm (27.4 in)
	Overall height	1,115 mm (43.9 in)
	Wheelbase	1,390 mm (54.7 in)
	Seat height	820 mm (32.3 in)
	Footpeg height	395 mm (15.6 in)
	Ground clearance	130 mm (5.1 in)
	Dry weight	
	49 states, Canada type:	169 kg (373 lbs)
	California type:	169 kg (373 lbs)
	Curb weight	
	49 states, Canada type:	199 kg (439 lbs)
	California type:	202 kg (445 lbs)
FRAME	Maximum weight capacity	
	49 states, California type:	166 kg (366 lbs)
	Canada type:	170 kg (375 lbs)
	Frame type	Diamond
	Front suspension	Telescopic fork
	Front axle travel	102.7 mm (4.04 in)
	Rear suspension	Swingarm
	Rear axle travel	130 mm (5.12 in)
	Front tire size	120/70ZR17 M/C (58W)
	Rear tire size	180/55ZR17 M/C (73W)
	Front tire brand	BT012F RADIAL G (Bridgestone) D208FK (Dunlop) Pilot SPORT E (Michelin)
	Rear tire brand	BT012R RADIAL L (Bridgestone) D208K (Dunlop) Pilot SPORT E (Michelin)
	Front brake	Hydraulic double disc
Rear brake	Hydraulic single disc	
Caster angle	24°	
Trail length	95 mm (3.7 in)	
Fuel tank capacity	18.0 liter (4.76 US gal, 3.96 Imp gal)	

GENERAL INFORMATION

LUBRICATION SYSTEM SPECIFICATIONS

ITEM		STANDARD	Unit: mm (in) SERVICE LIMIT
Engine oil capacity	After draining	2.6 liter (2.7 US qt, 2.3 Imp qt)	-
	After oil filter change	2.9 liter (3.1 US qt, 2.6 Imp qt)	-
	After disassembly	3.5 liter (3.7 US qt, 3.1 Imp qt)	-
Recommended engine oil		Pro Honda GN4 or HP4 (without molybdenum additives) 4-stroke oil (U.S.A. & Canada) or Honda 4-stroke oil (Canada only) or an equivalent motorcycle oil API service classification SG or Higher except oils labeled as energy conserving on the circular API service label JASO T 903 standard: MA Viscosity: SAE 10W-40	-
Oil pressure at oil pressure switch		540 kPa (5.5 kgf/cm ² , 78 psi) at 6,000 rpm/(80°C/176°F)	-
Oil pump	Tip clearance	0.15 (0.006)	0.20 (0.008)
	Body clearance	0.15 - 0.21 (0.006 - 0.008)	0.35 (0.014)
	Side clearance	0.04 - 0.09 (0.002 - 0.004)	0.17 (0.007)

FUEL SYSTEM (Programmed Fuel Injection) SPECIFICATIONS

ITEM		SPECIFICATIONS
Throttle body identification number	49 states, Canada type:	GQ63C
	California type:	GQ63B
Starter valve vacuum difference		20mm Hg
Base throttle valve for synchronization		No. 3
Idle speed		1,300 ± 100 rpm
Throttle grip free play		2 - 4 mm (1/16 - 1/8 in)
Intake air temperature sensor resistance (at 20°C/68°F)		1 - 4 kΩ
Engine coolant temperature sensor resistance (at 20°C/68°F)		2.3 - 2.6 kΩ
Fuel injection resistance (at 20°C/68°F)	Secondary injector	10.5 - 14.5 Ω
	Primary injector	10.5 - 14.5 Ω
PAIR control solenoid valve resistance (at 20°C/68°F)		20 - 24 Ω
Cam pulse generator peak voltage (at 20°C/68°F)		0.7 V minimum
Ignition pulse generator peak voltage (at 20°C/68°F)		0.7 V minimum
Manifold absolute pressure at idle		150 - 250 mm Hg
Fuel pressure at idle		343 kPa (3.5 kgf/cm ² , 50 psi)
Fuel pump flow (at 12V)		189 cm ³ (6.4 US oz, 6.7 Imp oz) minimum/10 seconds

COOLING SYSTEM SPECIFICATIONS

ITEM		SPECIFICATIONS
Coolant capacity	Radiator and engine	3.2 liter (3.4 US qt, 2.8 Imp qt)
	Reserve tank	0.30 liter (0.32 US qt, 0.26 Imp qt)
Radiator cap relief pressure		108 - 137 kPa (1.1 - 1.4 kgf/cm ² , 16 - 20 psi)
Thermostat	Begin to open	80 - 84 °C (176 - 183 °F)
	Valve lift	8 mm (0.3 in) minimum at 90°C (194°F)
Recommended antifreeze		Pro Honda HP Coolant or an equivalent high quality ethylene glycol antifreeze containing corrosion protection inhibitors
Standard coolant concentration		1 : 1 mixture of antifreeze and soft water

GENERAL INFORMATION

CYLINDER HEAD/VALVES SPECIFICATIONS

Unit: mm (in)

ITEM		STANDARD		SERVICE LIMIT
Cylinder compression		1,226 kPa (12.5 kgf/cm ² , 178psi) at 350 rpm		
Valve clearance		IN	0.20 ± 0.03 (0.008 ± 0.001)	-
		EX	0.28 ± 0.03 (0.011 ± 0.001)	-
Camshaft	Cam lobe height	IN	36.36 – 36.60 (1.431 – 1.441)	36.34 (1.431)
		EX	35.34 – 35.58 (1.391 – 1.401)	35.32 (1.391)
	Runout	-		0.05 (0.002)
	Oil clearance	0.020 – 0.062 (0.0008 – 0.0024)		0.10 (0.004)
Valve lifter	Valve lifter O.D.	25.978 – 25.993 (1.0228 – 1.0233)		25.97 (1.022)
	Valve lifter bore I.D.	26.010 – 26.026 (1.0240 – 1.0246)		26.04 (1.025)
Valve, valve guide	Valve stem O.D.	IN	3.975 – 3.990 (0.1565 – 0.1571)	3.965 (0.1561)
		EX	3.965 – 3.980 (0.1561 – 0.1567)	3.955 (0.1557)
	Valve guide I.D.	IN/EX	4.000 – 4.012 (0.1575 – 0.1580)	4.04 (0.159)
	Stem-to-guide clearance	IN	0.010 – 0.037 (0.0004 – 0.0015)	0.075 (0.0030)
		EX	0.020 – 0.047 (0.0008 – 0.0019)	0.085 (0.0033)
	Valve guide projection above cylinder head	IN	17.1 – 17.4 (0.67 – 0.69)	-
		EX	13.3 – 13.6 (0.52 – 0.54)	-
	Valve seat head	IN	0.90 – 1.10 (0.035 – 0.043)	1.5 (0.06)
EX		0.90 – 1.10 (0.035 – 0.043)	1.5 (0.06)	
Valve spring free length	IN	Inner	36.17 (1.424)	35.1 (1.38)
		Outer	39.76 (1.565)	38.8 (1.53)
	EX	Inner	35.34 (1.391)	34.4 (1.35)
		Outer	39.05 (1.537)	38.1 (1.50)
Cylinder head warpage		-		0.10 (0.004)

CLUTCH/STARTER CLUTCH/GEARSHIFT LINKAGE SPECIFICATIONS

Unit: mm (in)

ITEM		STANDARD		SERVICE LIMIT
Clutch lever free play		10 – 20 (3/8 – 13/16)		-
Clutch	Spring free length	46.5 (1.83)		45.2 (1.78)
	Disc thickness	2.92 – 3.08 (0.115 – 0.121)		2.6 (0.10)
	Plate warpage	-		0.30 (0.012)
Clutch outer guide A (Without ID mark)	I.D.	24.993 – 25.003 (0.9840 – 0.9844)		25.013 (0.9848)
	O.D.	35.004 – 35.012 (1.3781 – 1.3784)		34.994 (1.3777)
Clutch outer guide B (With ID mark)	I.D.	24.993 – 25.003 (0.9840 – 0.9844)		25.013 (0.9848)
	O.D.	34.996 – 35.004 (1.3778 – 1.3781)		34.986 (1.3774)
Primary driven gear I.D.	A	41.008 – 41.016 (1.6145 – 1.6148)		41.026 (1.6152)
	B	41.000 – 41.008 (1.6142 – 1.6145)		41.018 (1.6149)
Oil pump drive sprocket guide	I.D.	25.000 – 25.021 (0.9843 – 0.9851)		25.031 (0.9855)
	O.D.	34.950 – 34.975 (1.3760 – 1.3770)		34.940 (1.3756)
Oil pump drive sprocket I.D.	35.025 – 35.145 (1.3789 – 1.3837)		35.155 (1.3841)	
Mainshaft O.D. at clutch outer guide	24.980 – 24.990 (0.9835 – 0.9839)		24.960 (0.9827)	
Mainshaft O.D. at oil pump drive sprocket guide	24.980 – 24.990 (0.9835 – 0.9839)		24.960 (0.9827)	
Starter driven gear boss O.D.	45.657 – 45.673 (1.7975 – 1.7981)		45.642 (1.7969)	

GENERAL INFORMATION

CRANKCASE/TRANSMISSION SPECIFICATIONS

ITEM			STANDARD	Unit: mm (in)	SERVICE LIMIT
Shift fork	I.D.		12.000 – 12.018 (0.4724 – 0.4731)		12.03 (0.474)
	Claw thickness		5.93 – 6.00 (0.233 – 0.236)		5.9 (0.23)
Shift fork shaft O.D.			11.957 – 11.968 (0.4707 – 0.4712)		11.95 (0.470)
Transmission	Gear I.D.	M5, M6	28.000 – 28.021 (1.1024 – 1.1032)		28.04 (1.104)
		C1	24.000 – 24.021 (0.9449 – 0.9457)		26.04 (1.025)
		C2, C3, C4	31.000 – 31.025 (1.2205 – 1.2215)		31.04 (1.222)
	Gear busing O.D.	M5, M6	27.959 – 27.980 (1.1007 – 1.1016)		27.94 (1.100)
		C2	30.955 – 30.980 (1.2187 – 1.2197)		30.94 (1.218)
		C3, C4	30.950 – 30.975 (1.2185 – 1.2195)		30.93 (1.218)
	Gear-to-bushing clearance	M5, M6	0.020 – 0.062 (0.0008 – 0.0024)		0.10 (0.004)
		C2	0.020 – 0.070 (0.0008 – 0.0028)		0.10 (0.004)
		C3, C4	0.025 – 0.075 (0.0010 – 0.0030)		0.11 (0.004)
	Gear bushing I.D.	M5	24.985 – 25.006 (0.9837 – 0.9845)		25.016 (0.9849)
		C2	27.985 – 28.006 (1.1018 – 1.1026)		28.021 (1.1032)
	Mainshaft O.D.	at M5	24.967 – 24.980 (0.9830 – 0.9835)		24.96 (0.983)
	Countershaft O.D.	at C2	27.967 – 27.980 (1.1011 – 1.1016)		27.96 (1.101)
	Bushing to shaft clearance	M5	0.005 – 0.039 (0.0002 – 0.0015)		0.06 (0.002)
C2		0.005 – 0.039 (0.0002 – 0.0015)		0.06 (0.002)	

CRANKSHAFT/PISTON/CYLINDER SPECIFICATIONS

ITEM			STANDARD	Unit: mm (in)	SERVICE LIMIT
Crankshaft	Connecting rod side clearance		0.15 – 0.30 (0.006 – 0.012)		0.35 (0.014)
	Crankpin bearing oil clearance		0.028 – 0.052 (0.0011 – 0.0020)		0.06 (0.002)
	Main journal bearing oil clearance		0.020 – 0.038 (0.0008 – 0.0015)		0.05 (0.002)
	Runout		–		0.05 (0.002)
Piston, piston rings	Piston O.D. at 10 (0.4) from bottom		66.965 – 66.985 (2.6364 – 2.6372)		66.90 (2.634)
	Piston pin bore I.D.		16.002 – 16.008 (0.6300 – 0.6302)		16.02 (0.631)
	Piston pin O.D.		15.994 – 16.000 (0.6297 – 0.6299)		15.98 (0.629)
	Piston-to-piston pin clearance		0.002 – 0.014 (0.0001 – 0.0006)		0.04 (0.002)
	Piston ring end gap	Top	0.10 – 0.20 (0.004 – 0.008)		0.4 (0.02)
		Second	0.21 – 0.31 (0.008 – 0.012)		0.5 (0.02)
		Oil (side rail)	0.2 – 0.7 (0.01 – 0.03)		1.0 (0.04)
	Piston ring-to-ring groove clearance	Top	0.030 – 0.060 (0.0012 – 0.0024)		0.10 (0.004)
Second		0.015 – 0.050 (0.0006 – 0.0020)		0.08 (0.003)	
Cylinder	I.D.		67.000 – 67.015 (2.6378 – 2.6384)		67.10 (2.642)
	Out of round		–		0.10 (0.004)
	Taper		–		0.10 (0.004)
	Warpage		–		0.10 (0.004)
Cylinder-to-piston clearance			0.015 – 0.050 (0.0006 – 0.0022)		0.10 (0.004)
Connecting rod small end I.D.			16.010 – 16.034 (0.6303 – 0.6313)		16.050 (0.6319)
Connecting rod-to-piston pin clearance			0.010 – 0.040 (0.0004 – 0.0016)		0.070 (0.0028)

GENERAL INFORMATION

FRONT WHEEL/SUSPENSION/STEERING SPECIFICATIONS

Unit: mm (in)

ITEM		STANDARD	SERVICE LIMIT
Minimum tire tread depth		-	1.5 (0.06)
Cold tire pressure	Driver only	250 kPa (2.50 kgf/cm ² , 36 psi)	-
	Driver and passenger	250 kPa (2.50 kgf/cm ² , 36 psi)	-
Axle runout		-	0.2 (0.01)
Wheel rim runout	Radial	-	2.0 (0.08)
	Axial	-	2.0 (0.08)
Wheel balance weight		-	60 g (2.1oz) max.
Fork	Spring free length	258.8 (10.19)	253.6 (9.98)
	Tube runout	-	0.20 (0.008)
	Recommended fork fluid	Pro Honda Suspension Fluid SS-8	-
	Fluid level	110 (4.3)	-
	Fluid capacity	531 ± 2.5 cm ³ (18.0 ± 0.08 US oz, 18.7 ± 0.09 Imp oz)	-
	Pre-load adjuster initial setting	14 mm (0.6 in) (4th groove from top)	-
	Rebound adjuster initial setting	2-1/2 turns out from full hard	-
	Compression adjuster initial setting	2 turns out from full hard	-
Steering head bearing pre-load		9.8 – 15 N·m (1.0 – 1.5 kgf·m)	-

REAR WHEEL/SUSPENSION SPECIFICATIONS

Unit: mm (in)

ITEM		STANDARD	SERVICE LIMIT
Minimum tire tread depth		-	2.0 (0.08)
Cold tire pressure	Driver only	290 kPa (2.90 kgf/cm ² , 42 psi)	-
	Driver and passenger	290 kPa (2.90 kgf/cm ² , 42 psi)	-
Axle runout		-	0.2 (0.01)
Wheel rim runout	Radial	-	2.0 (0.08)
	Axial	-	2.0 (0.08)
Wheel balance weight		-	60 g (2.1 oz) max.
Drive chain	Size/link	DID	DID525HV-120ZB
		RK	RK525ROZ1-120LJ-FZ
	Slack	25 – 35 (1 – 1-3/8)	-
Shock absorber	Spring pre-load adjuster standard position		Position 3
	Rebound damping adjuster initial setting		1-3/4 turns out from full hard
	Compression damping adjuster initial setting		2 turns out from full hard

GENERAL INFORMATION

HYDRAULIC BRAKE SPECIFICATIONS

ITEM		STANDARD	SERVICE LIMIT	
Front	Specified brake fluid	Honda DOT4 Brake Fluid	-	
	Brake disc thickness	4.4 - 4.6 (0.17 - 0.18)	3.5 (0.14)	
	Brake disc runout	-	0.30 (0.012)	
	Master cylinder I.D.	17.460 - 17.503 (0.6874 - 0.6891)	17.515 (0.6896)	
	Master piston O.D.	17.321 - 17.367 (0.6819 - 0.6837)	17.309 (0.6815)	
	Caliper cylinder I.D.	A	32.030 - 32.080 (1.2610 - 1.2630)	32.092 (1.2635)
		B	30.230 - 30.280 (1.1902 - 1.1921)	30.292 (1.1926)
	Caliper piston O.D.	A	31.948 - 31.998 (1.2578 - 1.2598)	31.940 (1.2574)
		B	30.082 - 30.115 (1.1843 - 1.1856)	30.074 (1.1840)
	Rear	Specified brake fluid	Honda DOT4 Brake Fluid	-
Brake pedal height		75 (3.0)	-	
Brake disk thickness		4.8 - 5.2 (0.19 - 0.20)	4.0 (0.16)	
Brake disc runout		-	0.30 (0.012)	
Master cylinder I.D.		15.870 - 15.913 (0.6248 - 0.6265)	15.925 (0.6270)	
Master piston O.D.		15.827 - 15.854 (0.6231 - 0.6242)	15.815 (0.6226)	
Caliper cylinder I.D.		38.180 - 38.230 (1.5031 - 1.5051)	38.24 (1.506)	
Caliper piston O.D.		38.098 - 38.148 (1.4999 - 1.5019)	38.09 (1.500)	

BATTERY/CHARGING SYSTEM SPECIFICATIONS

ITEM		SPECIFICATIONS	
Battery	Capacity	12V - 8.6 Ah	
	Current leakage	2.0 mA max.	
	Voltage (20°C/68°F)	Fully charged	13.0 - 13.2 V
		Needs charging	Below 12.4 V
	Charging current	Normal	0.9 A/5 - 10 h
Quick		4.5 A/1 h	
Alternator	Capacity	0.333 kW/5,000 rpm	
	Charging coil resistance (20°C/68°F)	0.1 - 1.0 Ω	

IGNITION SYSTEM SPECIFICATIONS

ITEM	SPECIFICATIONS
Spark plug (Iridium)	IMR9C-9HE (NGK)
Spark plug gap	0.80 - 0.90 mm (0.031 - 0.035 in)
Ignition coil peak voltage	100 V minimum
Ignition pulse generator peak voltage	0.7 V minimum
Ignition timing ("F"mark)	15° BTDC at idle

ELECTRIC STARTER SPECIFICATIONS

ITEM	STANDARD	SERVICE LIMIT
Starter motor brush length	12.0 - 13.0 (0.47 - 0.51)	6.5 (0.26)

LIGHTS/METERS/SWITCHES SPECIFICATIONS

ITEM		SPECIFICATIONS	
Bulbs	Headlight	Hi	12V - 55 W
		Lo	12V - 55 W
	Position light	12V - 5 W	
	Brake/tail light	LED	
	Turn signal light	12V - 21 W X 4	
	Instrument light	LED	
	Turn signal indicator	LED	
	High beam indicator	LED	
	Neutral indicator	LED	
	PGM-FI warning indicator	LED	
Fuse	Main fuse	30 A	
	PGM-FI fuse	20 A	
	Sub fuse	10 A X 4, 20 A X 2	
Tachometer peak voltage		10.5 V minimum	
ECT sensor resistance	80°C (176 °F)	2.1 - 2.6 kΩ	
	120 °C (248 °F)	0.65 - 0.73 kΩ	

GENERAL INFORMATION

STANDARD TORQUE VALUES

FASTENER TYPE	TORQUE N·m (kgf·m, lbf·ft)	FASTENER TYPE	TORQUE N·m (kgf·m, lbf·ft)
5 mm hex bolt and nut	4.9 (0.5, 3.6)	5 mm screw	3.9 (0.4, 2.9)
6 mm hex bolt and nut	9.8 (1.0, 7)	6 mm screw	8.8 (0.9, 6.5)
8 mm hex bolt and nut	22 (2.2, 16)	6 mm flange bolt (8 mm head, small flange)	9.8 (1.0, 7)
10 mm hex bolt and nut	34 (3.5, 25)	6 mm flange bolt (8 mm head, large flange)	12 (1.2, 9)
12 mm hex bolt and nut	54 (5.5, 40)	6 mm flange bolt (10 mm head) and nut	12 (1.2, 9)
		8 mm flange bolt and nut	26 (2.7, 20)
		10 mm flange bolt and nut	39 (4.0, 29)

ENGINE & FRAME TORQUE VALUES

- Torque specifications listed below are for important fasteners.
- Others should be tightened to standard torque values listed above.

NOTE:

1. Apply sealant to the threads.
2. Apply a locking agent to the threads.
3. Stake.
4. Apply oil to the threads and flange surface.
5. U-nut.
6. ALOC bolt/screw: replace with a new one.
7. Apply grease to the threads.
8. Apply molybdenum disulfide oil to the threads and seating surface
9. CT bolt

ENGINE

MAINTENANCE

ITEM	Q'TY	THREAD DIA. (mm)	TORQUE N·m (kgf·m, lbf·ft)	REMARKS
Spark plug	4	10	16 (1.6, 12)	
Timing hole cap	1	45	18 (1.8, 13)	NOTE 7
Engine oil filter cartridge	1	20	26 (2.7, 20)	NOTE 4
Engine oil drain bolt	1	12	29 (3.0, 22)	

LUBRICATION

ITEM	Q'TY	THREAD DIA. (mm)	TORQUE N·m (kgf·m, lbf·ft)	REMARKS
Oil pump assembly flange bolt	1	6	7.8 (0.8, 5.8)	NOTE 9
Oil filter boss (stud side)	1	20	18 (1.8, 13)	NOTE 2

FUEL SYSTEM (Programmed Fuel Injection)

ITEM	Q'TY	THREAD DIA. (mm)	TORQUE N·m (kgf·m, lbf·ft)	REMARKS
ECT (Engine Coolant Temperature) sensor	1	12	23 (2.3, 17)	
Throttle body insulator band screw	8	5	See page 1-15	
Starter valve lock nut	4	10	1.8 (0.18, 1.3)	
Starter valve synchronization plate screw	4	3	0.9 (0.09, 0.7)	
Fuel pipe mounting bolt	3	6	9.8 (1.0, 7)	
Fast idle wax unit link plate screw	1	3	0.9 (0.09, 0.7)	
Fast idle wax unit mounting screw	2	6	4.9 (0.5, 3.6)	
Secondary injector bracket mounting bolt	5	5	5.4 (0.55, 4)	

GENERAL INFORMATION

COOLING SYSTEM

ITEM	Q'TY	THREAD DIA. (mm)	TORQUE N·m (kgf·m, lbf·ft)	REMARKS
Water pump assembly flange bolt	2	6	12 (1.2, 9)	NOTE 9
Thermostat housing cover flange bolt	2	6	13 (1.3, 10)	NOTE 9

ENGINE MOUNTING

ITEM	Q'TY	THREAD DIA. (mm)	TORQUE N·m (kgf·m, lbf·ft)	REMARKS
Drive sprocket special bolt	1	10	54 (5.5, 40)	

CYLINDER HEAD/VALVES

ITEM	Q'TY	THREAD DIA. (mm)	TORQUE N·m (kgf·m, lbf·ft)	REMARKS
Cylinder head mounting bolt	10	9	47 (4.8, 35)	NOTE 8
Camshaft holder bolt	20	6	12 (1.2, 9)	NOTE 4
Cylinder head sealing bolt	3	14	18 (1.8, 13)	NOTE 2
Cylinder head cover bolt	4	6	9.8 (1.0, 7)	
Breather plate bolt	3	6	13 (1.3, 9)	NOTE 2, 9
PAIR reed valve cover bolt	4	6	13 (1.3, 9)	NOTE 9
Cam sprocket bolt	4	7	20 (2.0, 14)	NOTE 2
Cam pulse generator rotor bolt	2	6	12 (1.2, 9)	NOTE 2
Cam chain tensioner lifter mounting socket bolt	2	6	9.8 (1.0, 7)	
Cam chain tensioner A pivot bolt	1	6	9.8 (1.0, 7)	NOTE 2
Cam chain tensioner B pivot bolt	1	10	20 (2.0, 14)	NOTE 2
Cam chain guide bolt	1	6	12 (1.2, 9)	
Cylinder block socket bolt	1	10	12 (1.2, 9)	NOTE 2

CLUTCH/GEARSHIFT LINKAGE

ITEM	Q'TY	THREAD DIA. (mm)	TORQUE N·m (kgf·m, lbf·ft)	REMARKS
Clutch center lock nut	1	22	127 (13.0, 94)	NOTE 3, 4
Clutch spring bolt	5	6	12 (1.2, 9)	
Oil pump driven sprocket bolt	1	6	15 (1.5, 11)	NOTE 2
Shift drum center socket bolt	1	8	23 (2.3, 17)	NOTE 2
Shift drum stopper arm pivot bolt	1	6	12 (1.2, 9)	
Gearshift spindle return spring pin	1	8	22 (2.2, 16)	

ALTERNATOR/STARTER CLUTCH

ITEM	Q'TY	THREAD DIA. (mm)	TORQUE N·m (kgf·m, lbf·ft)	REMARKS
Alternator stator socket bolt	4	6	12 (1.2, 9)	
Flywheel bolt	1	10	103 (10.5, 76)	NOTE 4
Stator wire clamp bolt	1	6	14 (1.4, 10)	NOTE 9

CRANKCASE/TRANSMISSION

ITEM	Q'TY	THREAD DIA. (mm)	TORQUE N·m (kgf·m, lbf·ft)	REMARKS
Mainshaft bearing set plate flange bolt	3	6	12 (1.2, 9)	NOTE 2
Gearshift drum bearing set bolt	2	6	12 (1.2, 9)	NOTE 2
Lower crankcase sealing bolt	2	20	28 (2.8, 20)	
Crankcase 6 mm bolt	10	6	12 (1.2, 9)	
8 mm bolt	6	8	25 (2.5, 18)	
8 mm bolt (main journal bolt)	10	8	15 (1.5, 10) + 120°	See page 12-17
10 mm bolt	1	10	39 (4.0, 29)	

GENERAL INFORMATION

CRANKSHAFT/PISTON/CYLINDER

ITEM	Q'TY	THREAD DIA. (mm)	TORQUE N·m (kgf·m, lbf·ft)	REMARKS
Connecting rod bearing cap bolt	8	7	14 (1.4, 10) + 90°	NOTE 4

IGNITION SYSTEM

ITEM	Q'TY	THREAD DIA. (mm)	TORQUE N·m (kgf·m, lbf·ft)	REMARKS
Starter clutch outer special bolt	1	10	74 (7.5, 54)	NOTE 4

ELECTRIC STARTER

ITEM	Q'TY	THREAD DIA. (mm)	TORQUE N·m (kgf·m, lbf·ft)	REMARKS
Starter motor terminal nut	17	6	12 (1.2, 9)	

LIGHTS/METERS/SWITCHES

ITEM	Q'TY	THREAD DIA. (mm)	TORQUE N·m (kgf·m, lbf·ft)	REMARKS
Oil pressure switch	1	PT 1/8	12 (1.2, 9)	NOTE 1
Oil pressure switch wire terminal screw	1	4	2.0 (0.2, 1.4)	
Neutral switch	1	10	12 (1.2, 9)	

GENERAL INFORMATION

Insulator clamp (Throttle body side):

$12 \pm 1 \text{ mm}$ ($0.5 \pm 0.04 \text{ in}$)

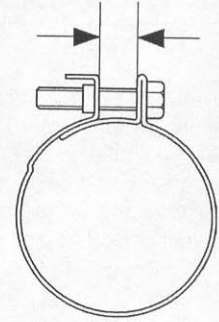

Insulator clamp (Cylinder head side):

$10 \pm 1 \text{ mm}$ ($0.4 \pm 0.04 \text{ in}$)

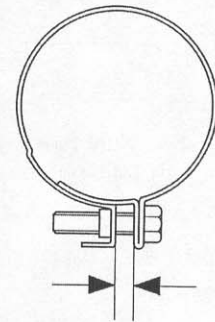

Exhaust pipe stud bolt:

$45.5 \pm 0.5 \text{ mm}$ ($1.79 \pm 0.04 \text{ in}$)

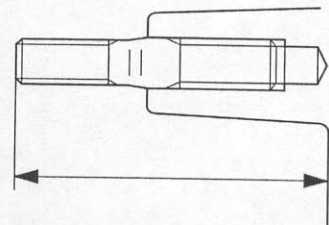

GENERAL INFORMATION

FRAME

FRAME BODY PANELS/EXHAUST SYSTEM

ITEM	Q'TY	THREAD DIA. (mm)	TORQUE N·m (kgf·m, lbf·ft)	REMARKS
Lower cowl-to-middle cowl pan screw	2	5	1.5 (0.15, 1.1)	
Middle cowl-to-upper cowl pan screw	4	5	1.5 (0.15, 1.1)	
Windscreen setting screw	6	5	0.5 (0.05, 0.4)	
Seat rail upper mounting flange nut	2	10	54 (5.5, 40)	
Seat rail lower mounting flange bolt	2	10	44 (4.5, 33)	
Seat rail brace socket bolt	4	8	26 (2.7, 20)	
Seat rail assembly flange nut	2	8	30 (3.1, 22)	
Exhaust pipe joint flange nut	8	7	12 (1.2, 9)	
Muffler band flange bolt	2	8	23 (2.3, 17)	
Passenger footpeg bracket socket bolt	4	8	26 (2.7, 20)	

FUEL SYSTEM

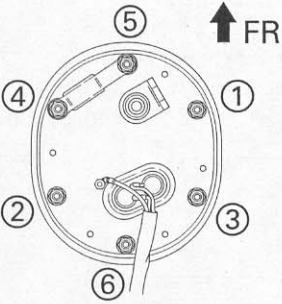
ITEM	Q'TY	THREAD DIA. (mm)	TORQUE N·m (kgf·m, lbf·ft)	REMARKS
Fuel filler cap socket bolt	3	4	1.8 (0.18, 1.3)	
Fuel feed hose banjo bolt (fuel tank side)	1	12	22 (2.2, 16)	
Fuel hose sealing nut (throttle body side)	1	12	22 (2.2, 16)	
Fuel pump mounting nut	6	6	12 (1.2, 9)	
				
	O ₂ sensor (California type only)	1	12	25 (2.6, 19)

COOLING SYSTEM

ITEM	Q'TY	THREAD DIA. (mm)	TORQUE N·m (kgf·m, lbf·ft)	REMARKS
Cooling fan nut	1	5	2.9 (0.3, 2.2)	NOTE 2
Fan motor nut	3	5	4.9 (0.5, 3.6)	
Fan motor shroud mounting bolt	3	6	7.8 (0.8, 5.8)	

ENGINE MOUNTING

ITEM	Q'TY	THREAD DIA. (mm)	TORQUE N·m (kgf·m, lbf·ft)	REMARKS
Front engine hanger bolt (left side)	1	12	54 (5.5, 40)	
Front engine hanger nut (right side)	1	12	54 (5.5, 40)	
Front engine hanger pinch bolt	2	10	27 (2.7, 20)	
Rear engine hanger adjusting bolt	1	20	9.8 (1.0, 7)	
Rear engine hanger lock nut	1	20	54 (5.5, 40)	
Rear engine hanger nut	1	12	59 (6.0, 43)	
Lower engine hanger pinch bolt	2	8	27 (2.7, 20)	
Lower engine hanger nut	1	12	59 (6.0, 43)	See page 8-10

GENERAL INFORMATION

FRONT WHEEL/SUSPENSION/STEERING

ITEM	Q'TY	THREAD DIA. (mm)	TORQUE N-m (kgf-m, lbf-ft)	REMARKS
Handlebar weight mounting screw	2	6	9.8 (1.0, 7)	NOTE 6
Front brake disc bolt	12	6	20 (2.0, 14)	NOTE 6
Front axle bolt	1	14	59 (6.0, 43)	
Front axle holder pinch bolt	4	8	22 (2.2, 16)	
Fork socket bolt	2	10	34 (3.5, 25)	NOTE 2
Fork bolt	2	42	23 (2.3, 17)	
Fork top bridge pinch bolt	2	8	23 (2.3, 17)	
Handlebar pinch bolt	2	8	23 (2.3, 17)	
Fork bottom bridge pinch bolt	2	8	27 (2.7, 20)	
Steering stem adjusting nut	1	26	49 (5.0, 36)	
Steering stem adjusting lock nut	1	26	-	See page 14-34
Steering stem nut	1	24	103 (10.5, 76)	

REAR WHEEL/SUSPENSION

ITEM	Q'TY	THREAD DIA. (mm)	TORQUE N-m (kgf-m, lbf-ft)	REMARKS
Rear brake disc bolt	4	8	42 (4.3, 31)	NOTE 6
Final driven sprocket nut	6	10	64 (6.5, 47)	NOTE 5
Rear axle nut	1	22	113 (11.5, 83)	NOTE 5
Rear shock absorber upper mounting nut	1	10	44 (4.5, 33)	NOTE 5
Rear shock absorber lower mounting nut	1	10	44 (4.5, 33)	NOTE 5
Shock link-to-frame pivot nut	1	10	44 (4.5, 33)	NOTE 5
Shock arm-to-shock link nut	1	10	44 (4.5, 33)	NOTE 5
Shock arm-to-swingarm nut	1	10	44 (4.5, 33)	NOTE 5
Rear shock absorber bracket mounting bolt	4	10	44 (4.5, 33)	NOTE 5
Drive chain slider flange bolt	3	6	8.8 (0.9, 6.5)	NOTE 2
Swingarm pivot pinch bolt	2	8	27 (2.7, 20)	
Swingarm pivot nut	1	18	93 (9.5, 69)	

HYDRAULIC BRAKE

ITEM	Q'TY	THREAD DIA. (mm)	TORQUE N-m (kgf-m, lbf-ft)	REMARKS
Front master cylinder reservoir cap screw	2	4	1.5 (0.15, 1.1)	
Front brake lever pivot bolt	1	6	1.0 (0.1, 0.7)	
Front brake lever pivot nut	1	6	5.9 (0.6, 4.3)	
Front brake light switch screw	1	4	1.0 (0.1, 0.7)	
Front master cylinder holder bolt	2	6	12 (1.2, 9)	
Front brake caliper assembly torx bolt	8	8	23 (2.3, 17)	NOTE 2
Front brake caliper mounting bolt	4	8	30 (3.1, 22)	NOTE 6
Rear master cylinder push rod joint nut	1	8	18 (1.8, 13)	
Rear master cylinder reservoir cap screw	2	4	1.5 (0.15, 1.1)	
Rear master cylinder mounting bolt	2	6	8.8 (0.9, 6.5)	
Rear brake reservoir mounting bolt	1	6	12 (1.2, 9)	
Rear brake reservoir hose joint screw	1	4	1.5 (0.15, 1.1)	NOTE 2
Rear brake caliper mounting bolt	1	8	23 (2.3, 17)	
Rear brake caliper slide pin bolt	1	12	27 (2.8, 20)	
Front brake caliper pad pin	2	10	18 (1.8, 13)	
Rear brake caliper pad pin	1	10	18 (1.8, 13)	
Brake hose oil bolt	5	10	34 (3.5, 25)	
Front brake hose clamp bolt	2	6	12 (1.2, 9)	
Front brake hose 3-way joint bolt	1	6	12 (1.2, 9)	
Brake caliper bleed valve	3	8	5.9 (0.6, 4.3)	

GENERAL INFORMATION

LIGHTS/METERS/SWITCHES

ITEM	Q'TY	THREAD DIA. (mm)	TORQUE N·m (kgf·m, lbf·ft)	REMARKS
Side stand switch bolt	1	6	9.8 (1.0, 7)	NOTE 6
Ignition switch mounting bolt	2	8	25 (2.5, 18)	
Driver footpeg bracket socket bolt	4	8	37 (3.8, 28)	

OTHERS

ITEM	Q'TY	THREAD DIA. (mm)	TORQUE N·m (kgf·m, lbf·ft)	REMARKS
Side stand pivot bolt	1	10	9.8 (1.0, 7)	NOTE 6 NOTE 6
Side stand pivot lock nut	1	10	29 (3.0, 22)	
Side stand bracket socket bolt	2	10	39 (4.0, 29)	
Driver footpeg bolt	2	10	44 (4.5, 33)	
Driver footpeg cap bolt	2	6	11 (1.1, 8)	

LUBRICATION & SEAL POINTS

ENGINE

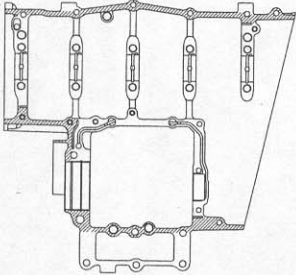
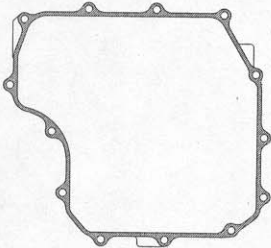
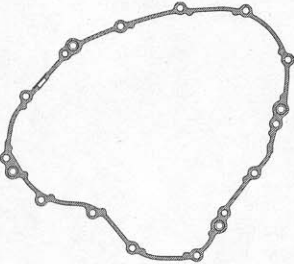
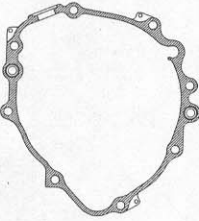
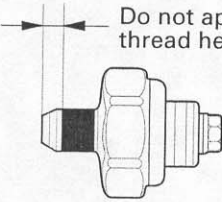
LOCATION	MATERIAL	REMARKS		
<p>Crankcase mating surface</p> 	<p>Liquid sealant (Three Bond 1207B or equivalent)</p>			
<p>Oil pan mating surface</p> 			<p>Liquid sealant (Three Bond 1207B or equivalent)</p>	
<p>Right crankcase cover mating surface</p> 				
<p>Alternator cover mating surface</p> 				
<p>Oil pressure switch threads</p>  <p>Do not apply sealant to the thread head 3 - 4 mm (0.1 - 0.2 in)</p>				

GENERAL INFORMATION

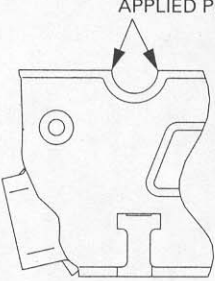
LOCATION	MATERIAL	REMARKS
Cylinder head semi-circular cut-out 	Sealant	
Main journal bearing surface Piston pin sliding surface Connecting rod bearing surface Connecting rod small end inner surface Crankshaft thrust surface Camshaft lobes/journals and thrust surface Valve stem (valve guide sliding surface) Valve lifter outer sliding surface Water pump shaft spline and thrust washer sliding surface Clutch outer/primary driven gear sliding surface Clutch outer guide sliding surface Oil pump gear and collar sliding surface M3/4, C5, C6 shifter gear (shift fork grooves) Starter reduction gear sliding surface Starter reduction gear shaft sliding surface	Molybdenum disulfide oil (a mixture of 1/2 engine oil and 1/2 molybdenum disulfide grease)	
Piston and piston ring sliding area Oil strainer packing Clutch disc surface Starter one-way clutch sliding surface Connecting rod bolt threads and seating surface Flywheel bolt threads and seating surface Cylinder head special bolt (after removing anti-rust oil additive) Clutch center lock nut threads and seating surface Oil filter cartridge threads and O-ring Camshaft holder bolt threads and seating surface Each gear teeth and rotating surface Each bearing Each O-ring Other rotating area and sliding surface	Engine oil	
Timing hole cap threads Each oil seal lips	Multi-purpose grease	
Upper crankcase sealing bolt threads Lower crankcase sealing bolt threads Cylinder head cover breather joint threads Cylinder head sealing bolt threads Cam pulse generator rotor bolt threads Oil pump driven sprocket bolt threads Oil cooler center bolt thread (stud side) Shift drum bearing set plate bolt threads Mainshaft bearing set plate bolt threads Cam sprocket bolt threads Cylinder head cover breather plate bolt threads Shift drum center bolt threads Cam chain tensioner pivot A bolt threads Cam chain tensioner pivot B bolt threads Spindle plate tightening bolt threads Spindle set plate tightening bolt threads	Locking agent	Coating width: 6.5 ± 1 mm Coating width: 6.5 ± 1 mm Coating width: 6.5 ± 1 mm Coating width: 6.5 ± 1 mm Coating width: 6.5 ± 1 mm Coating width: 6.5 ± 1 mm Coating width: 6.5 ± 1 mm Coating width: 6.5 ± 1 mm Coating width: 6.5 ± 1 mm Coating width: 6.5 ± 1 mm Coating width: 6.5 ± 1 mm

GENERAL INFORMATION

FRAME

LOCATION	MATERIAL	REMARKS
Seat catch hook sliding area Front wheel dust seal lips Final driven flange-to-rear wheel hub mating surface and O-ring Rear wheel dust seal lips Rear wheel side collar inner surface Throttle grip pipe flange Clutch lever pivot bolt sliding area Rear brake pedal pivot sliding area Gearshift pedal link tie-rod ball joints Gearshift pedal pivot Driver footpeg sliding area Pillion footpeg sliding area Side stand pivot Center stand pivot	Multi-purpose grease	
Steering head bearing sliding surface Steering head dust seal lips	Urea based multi-purpose grease with extreme pressure (example: EXCELIGHT EP2 manufactured by KYODO YUSH1, Japan), Shell stamina EP2 or equivalent	
Swingarm pivot bearings Swingarm pivot dust seal lips Shock arm and shock link needle bearings Shock arm and shock link dust seal lips Shock absorber needle bearings Shock absorber dust seal lips	Multi-purpose grease (Shell Alvania EP2 or equivalent)	
Throttle cable A, B outer inside Clutch cable outer inside Clutch cable outer inside	Cable lubricant	
Handlebar grip rubber inside	Honda bond A or Honda hand Grip Cement (U.S.A. only)	
Steering bearing adjustment nut threads	Engine oil	
Front brake lever-to-master piston contacting area Front brake lever pivot Rear master brake master piston-to-push rod contacting area Brake caliper dust seals Rear brake caliper boot inside Rear brake caliper pin boot inside	Silicone grease	
Brake master piston and cups Brake caliper piston and piston seals	Honda DOT 4 brake fluid	
Fork cap O-ring Fork dust seal and oil seal lips	Pro Honda Suspension Fluid SS-8	
Rear brake reservoir hose joint screw threads Front brake caliper assembly bolt threads Rear brake caliper pin bolt threads	Locking agent	

GENERAL INFORMATION

CABLE & HARNESS ROUTING

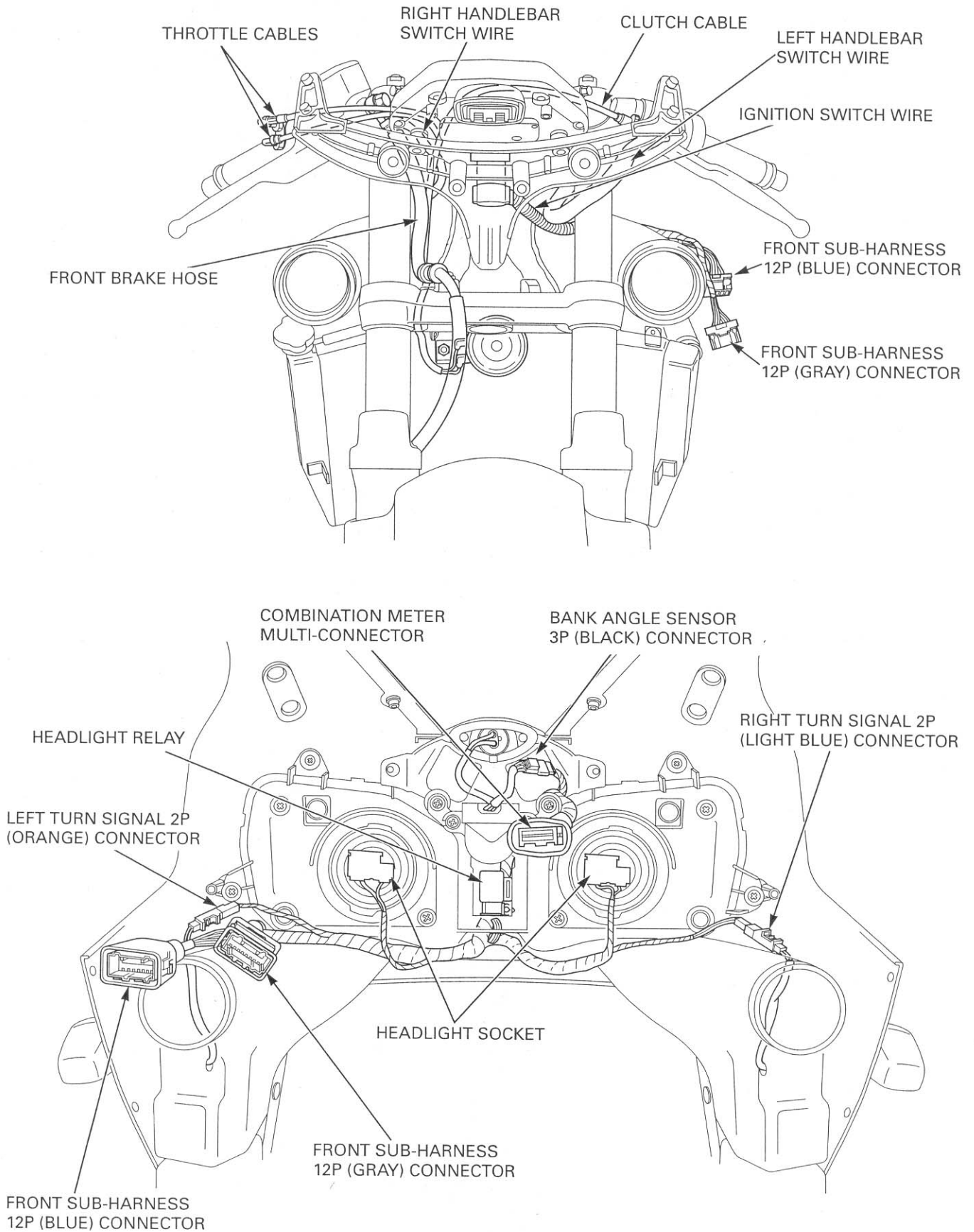

GENERAL INFORMATION

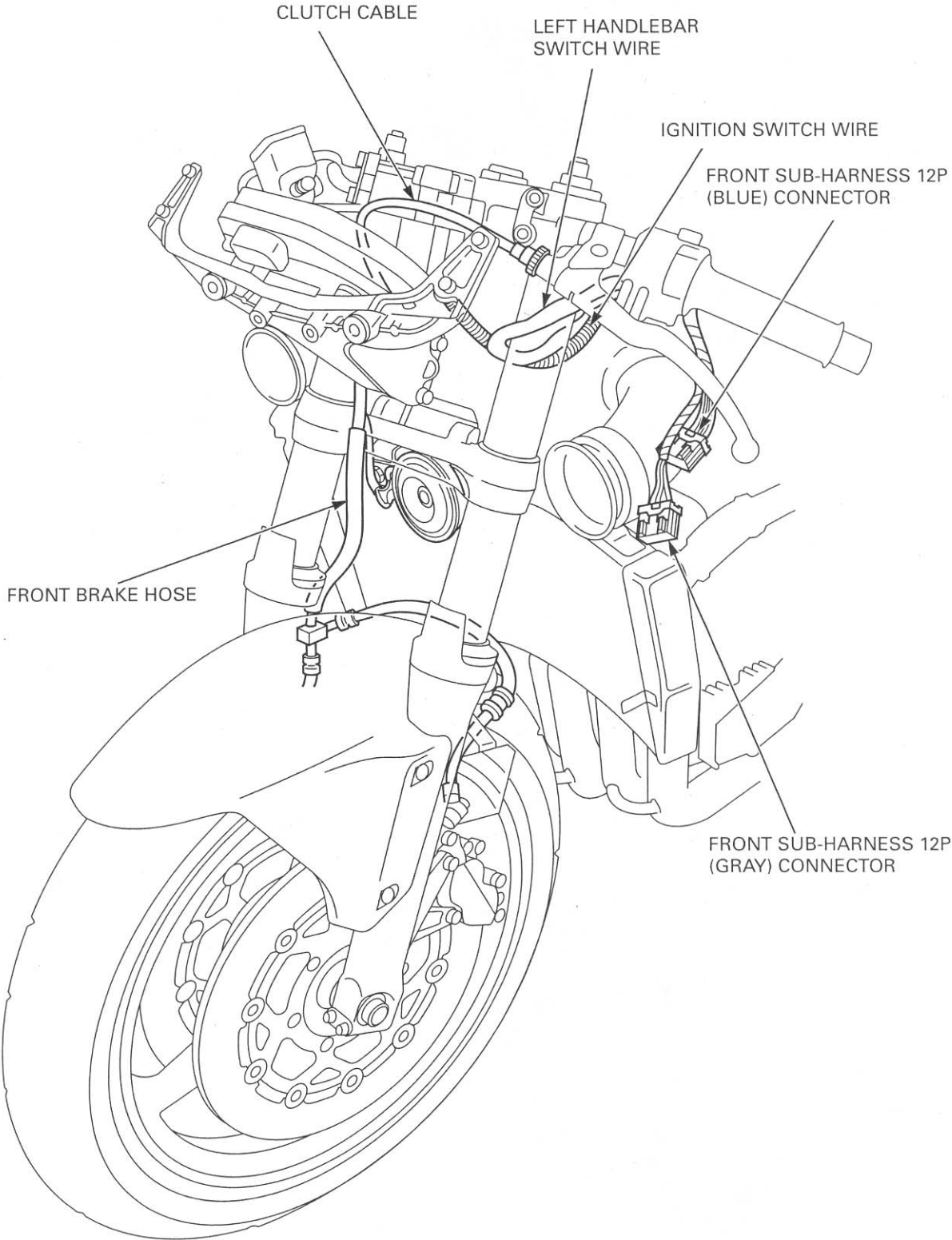

GENERAL INFORMATION

RIGHT HANDLEBAR
SWITCH WIRE

CLUTCH CABLE

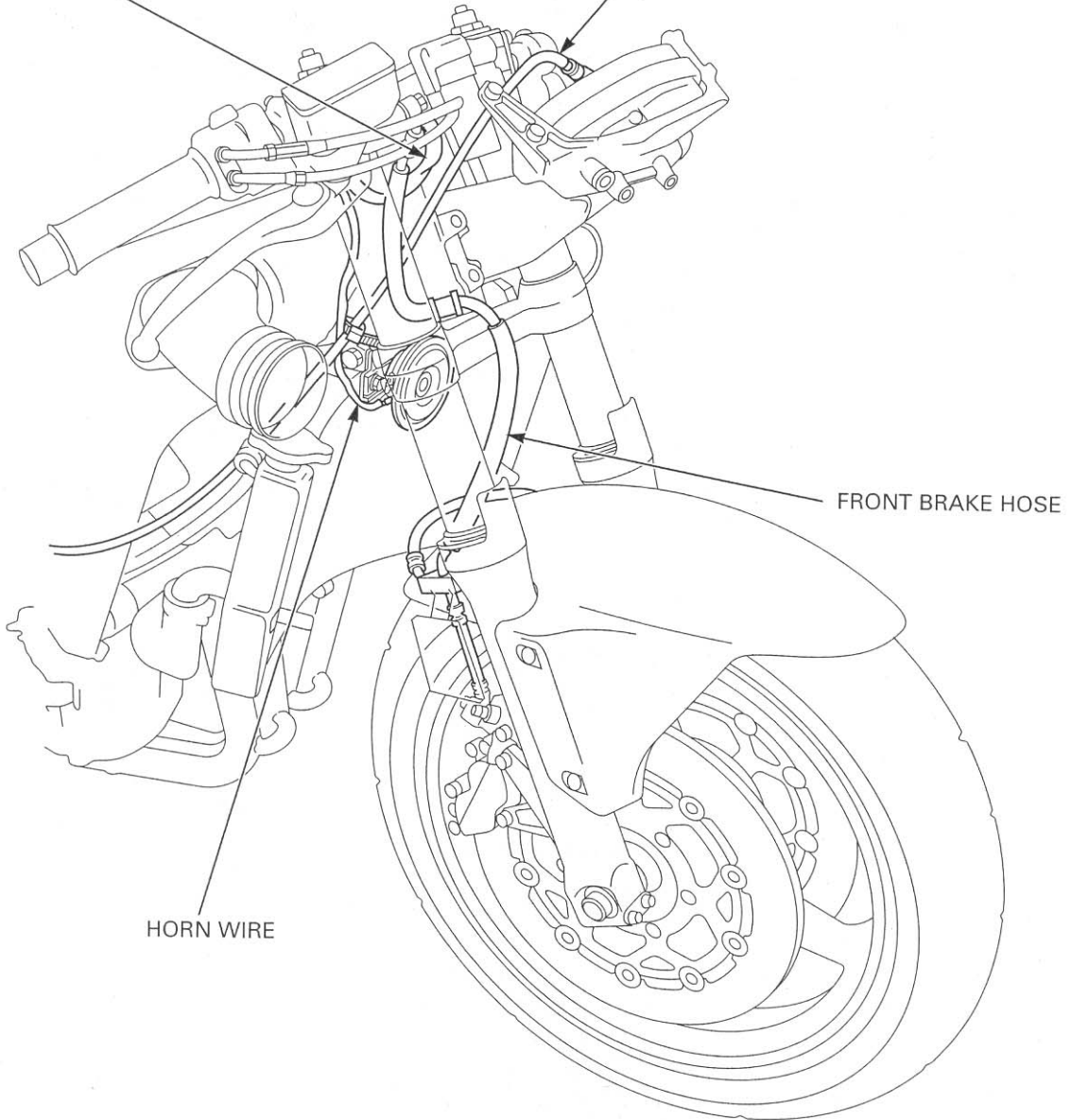

FRONT BRAKE HOSE

HORN WIRE

GENERAL INFORMATION

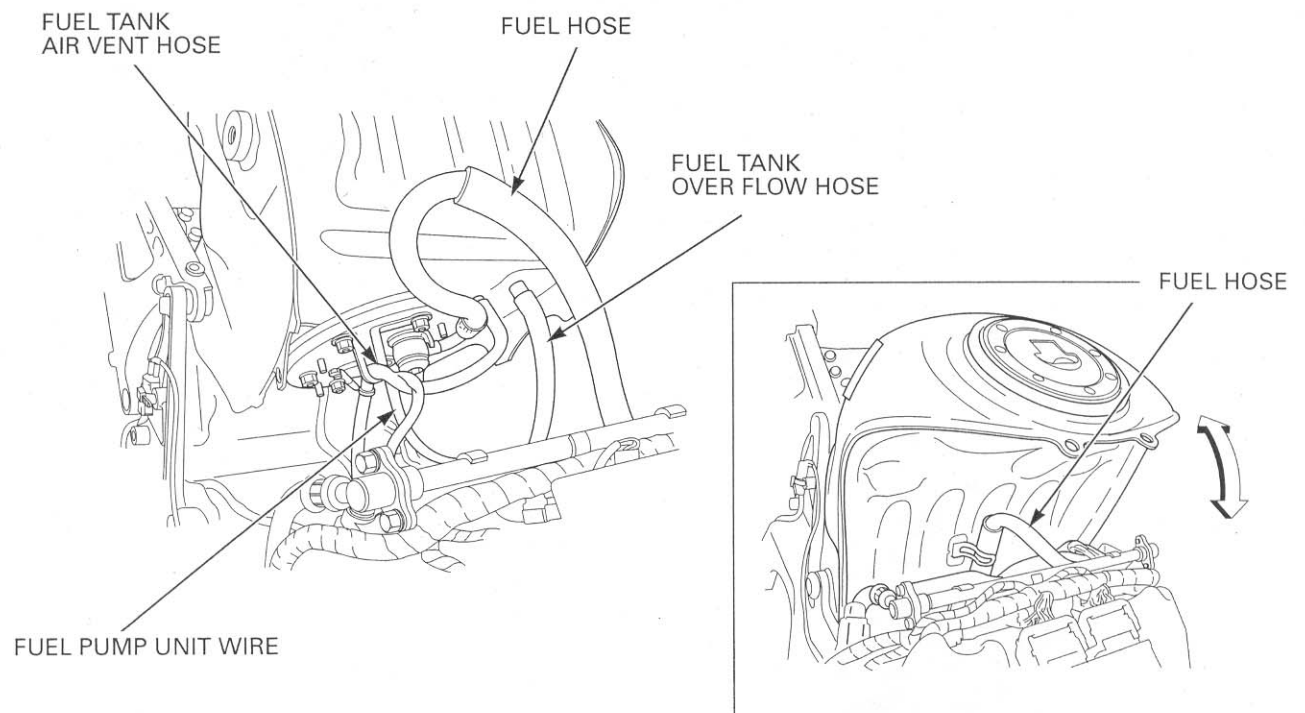
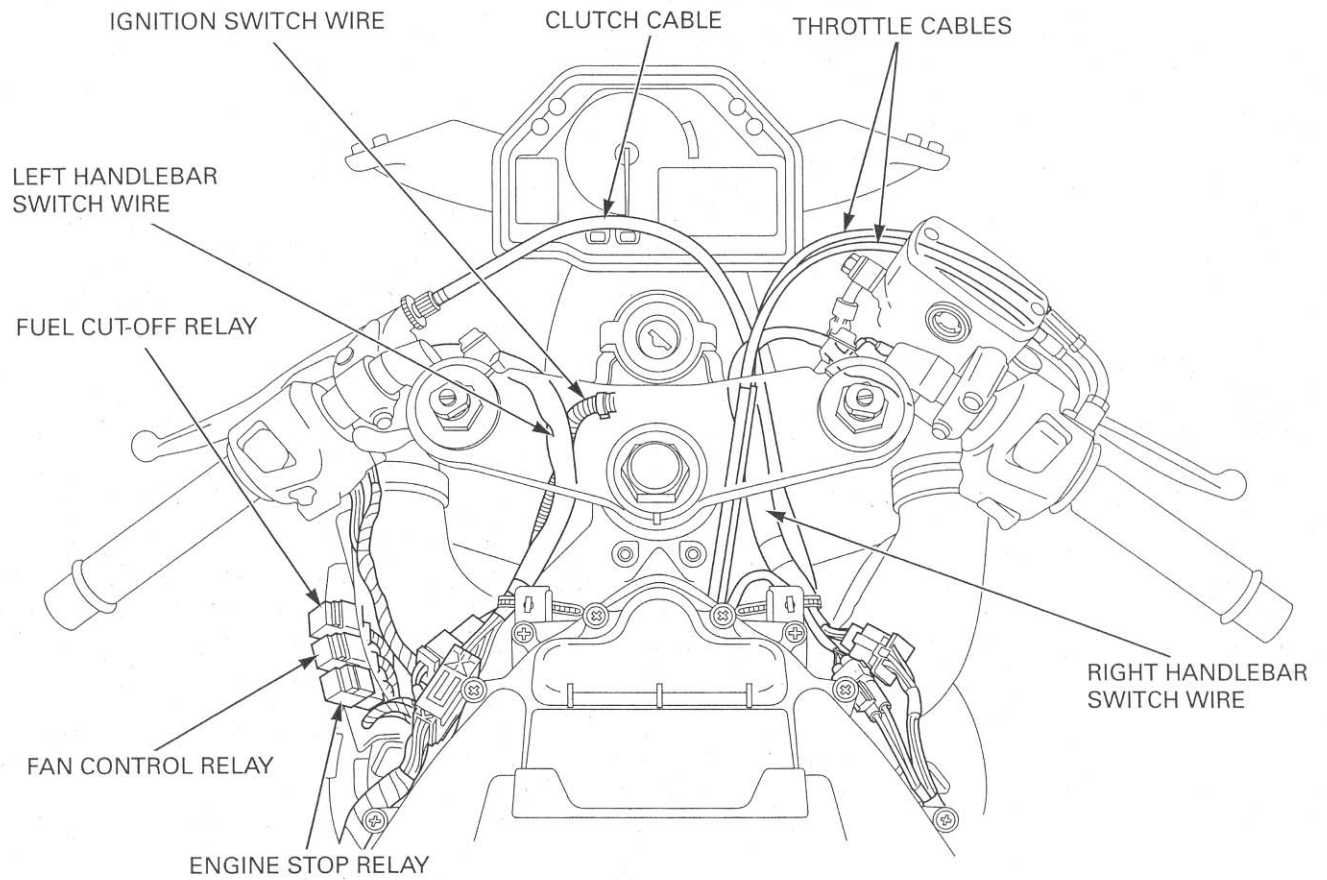

GENERAL INFORMATION

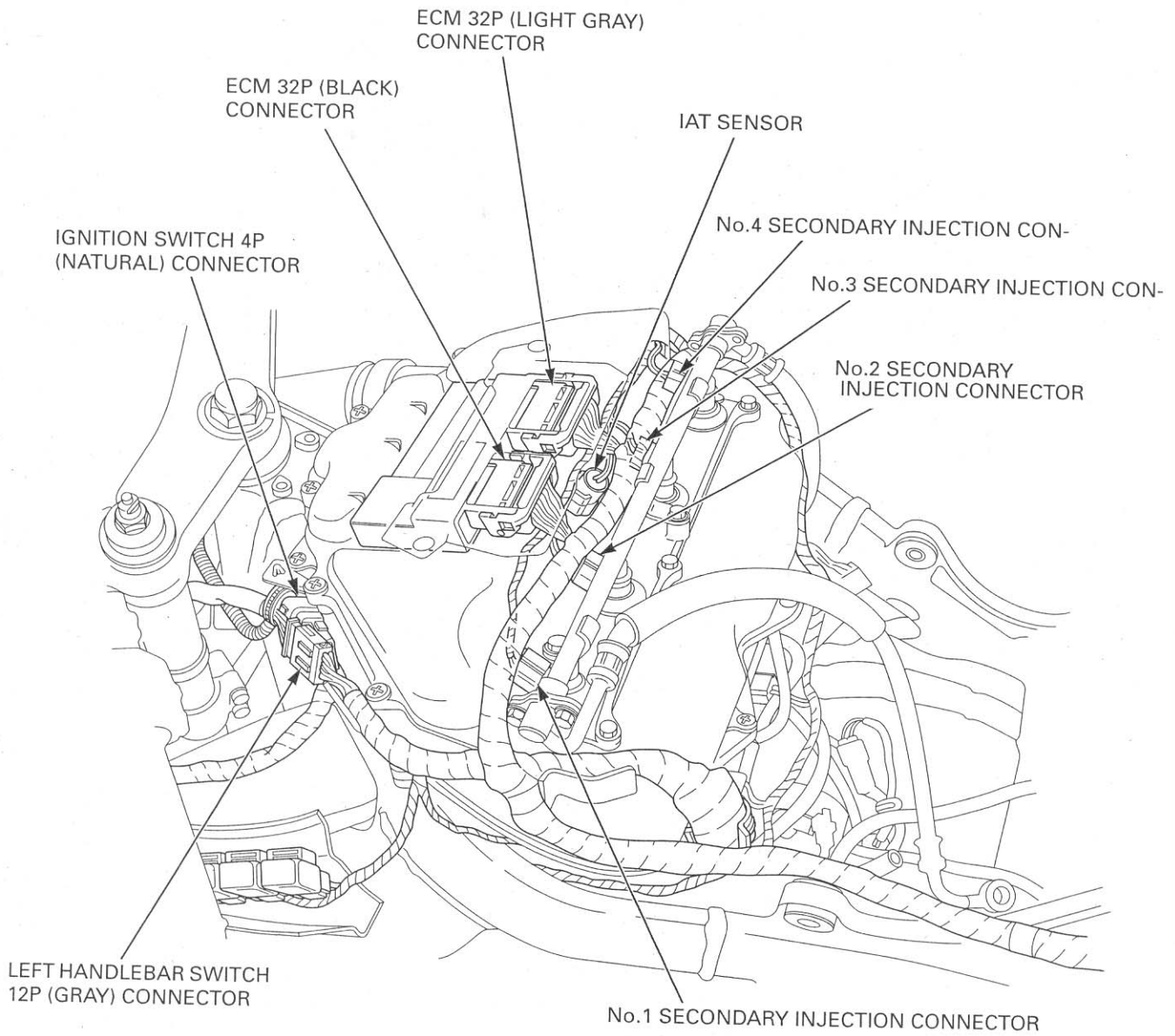

GENERAL INFORMATION

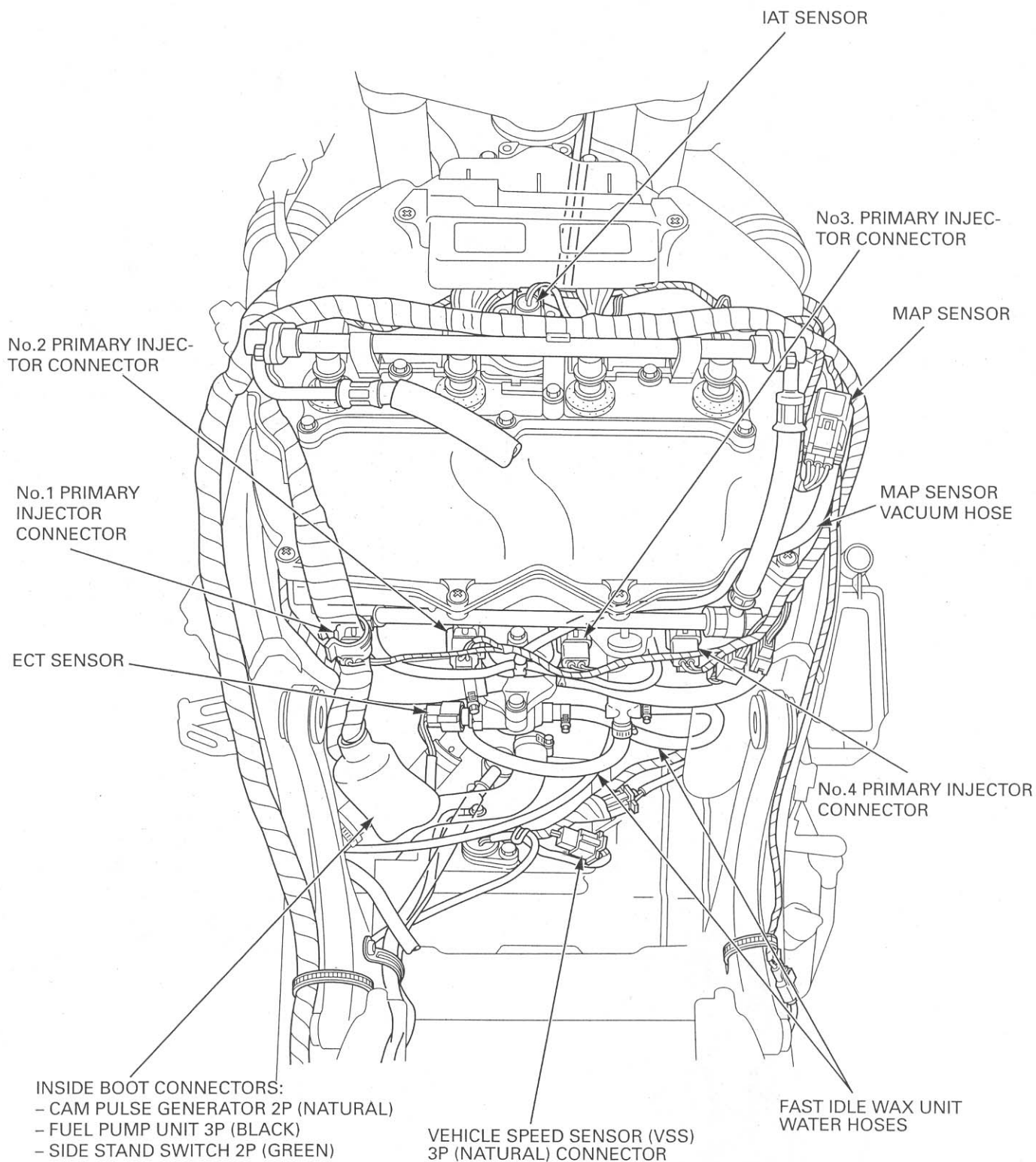

GENERAL INFORMATION

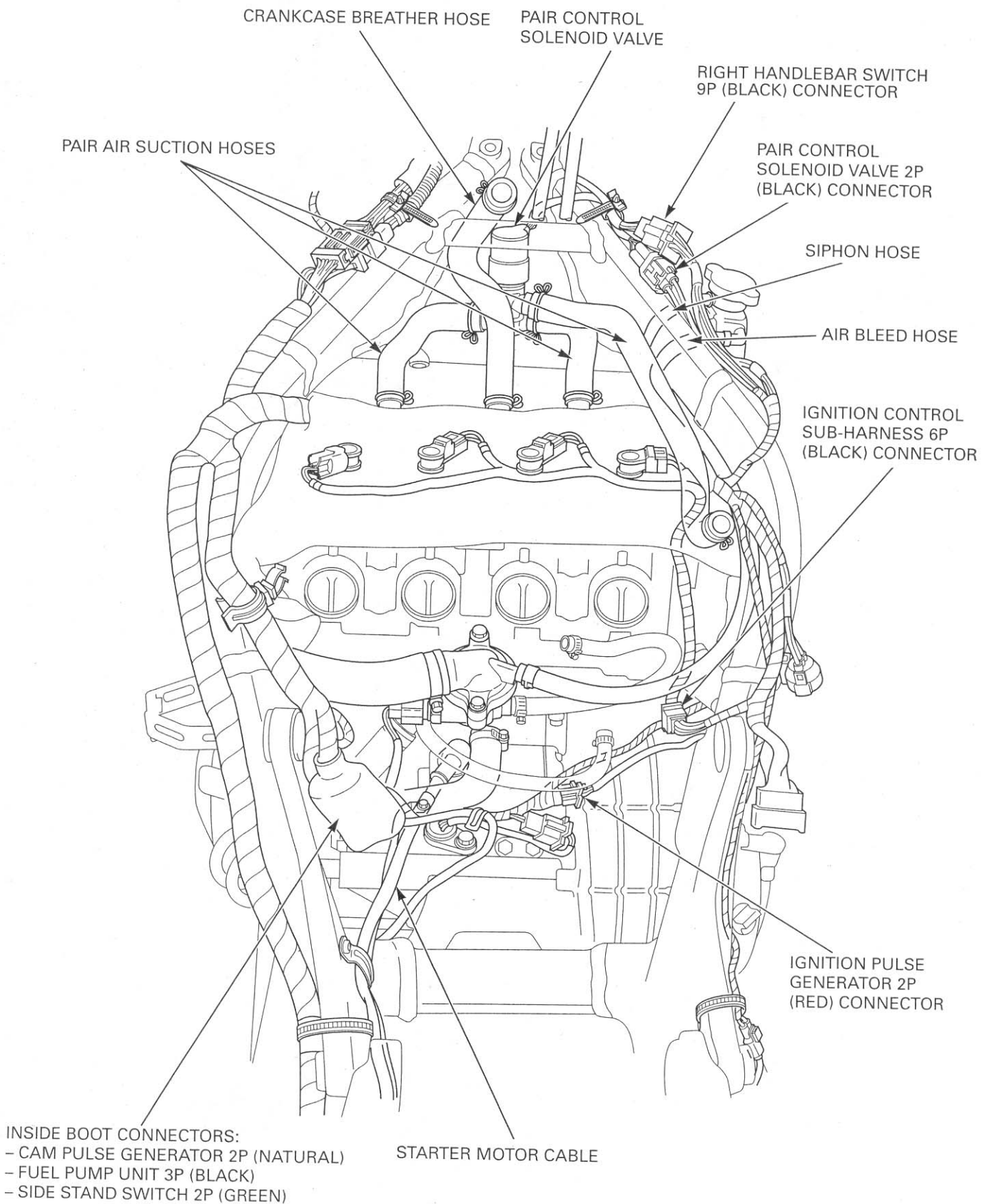

GENERAL INFORMATION

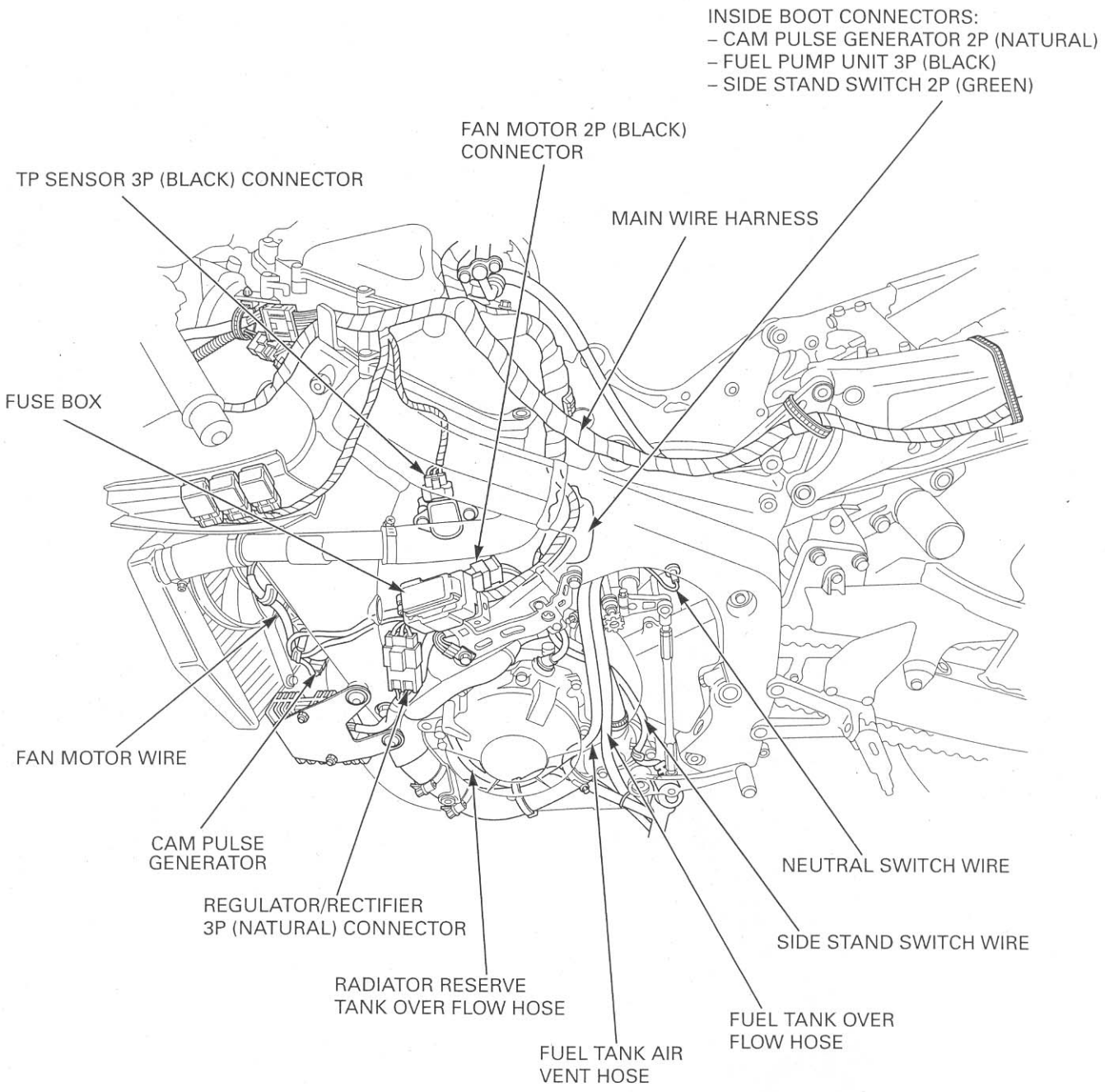

GENERAL INFORMATION

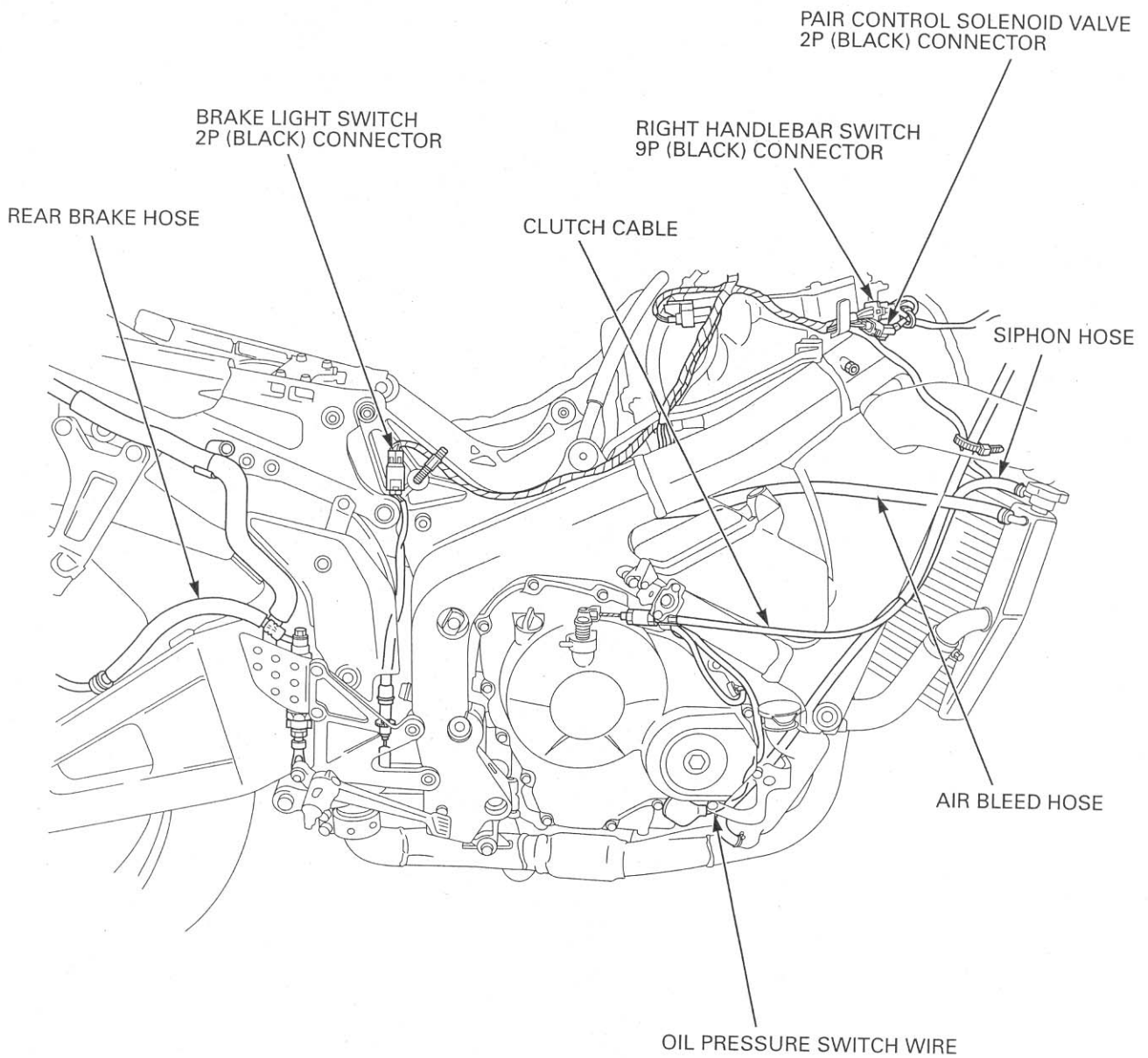

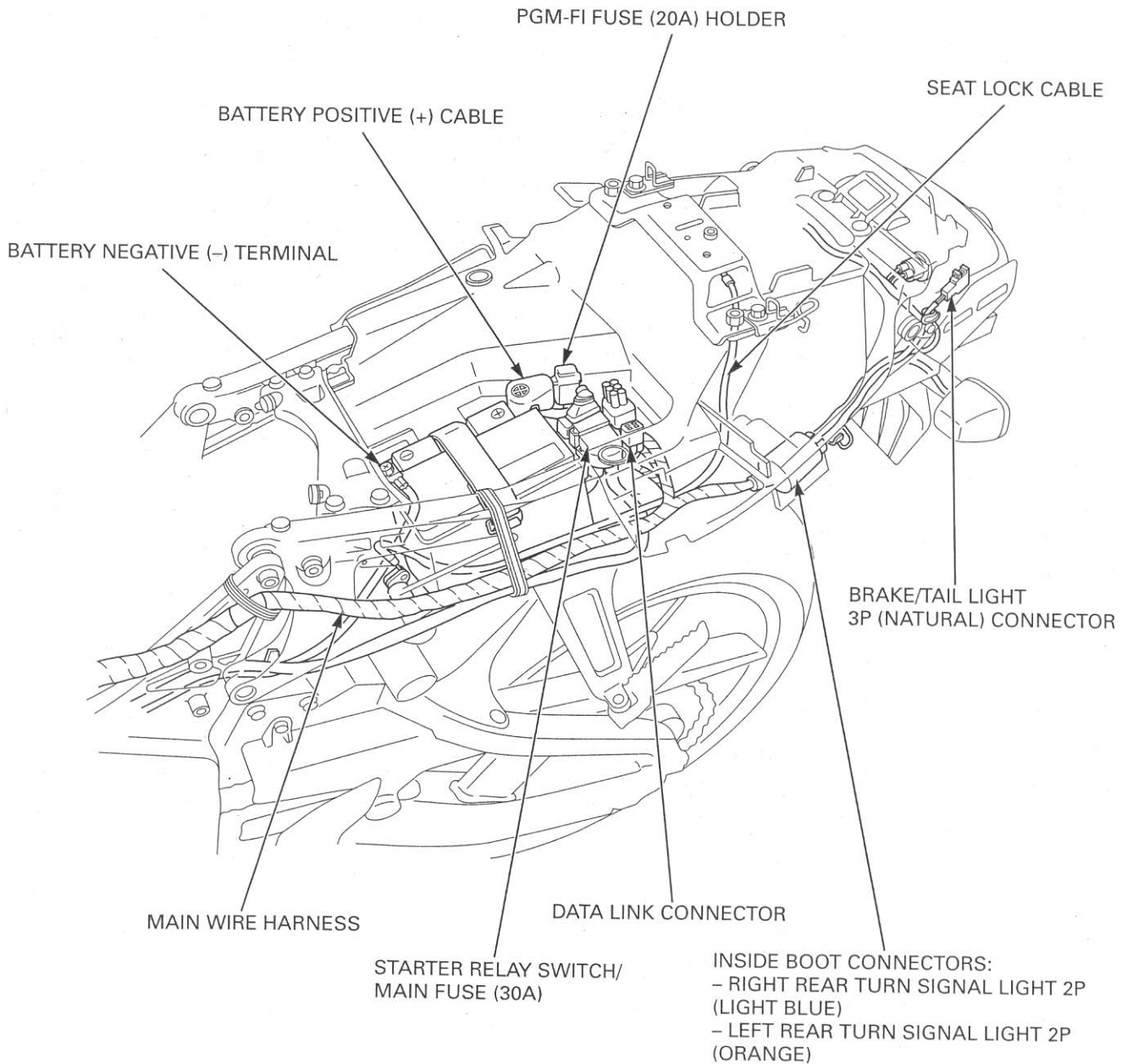

GENERAL INFORMATION

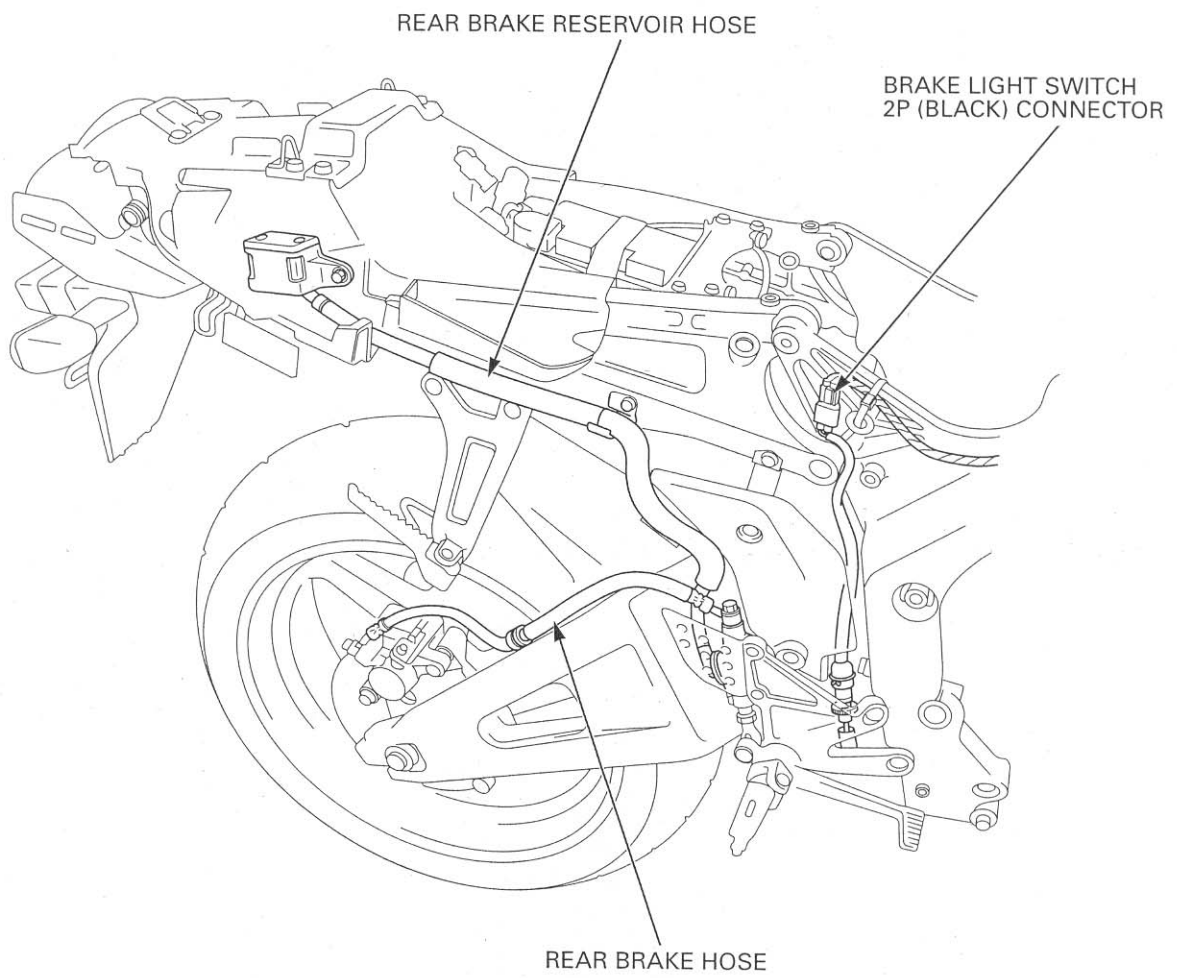

CALIFORNIA TYPE:

1-32

GENERAL INFORMATION

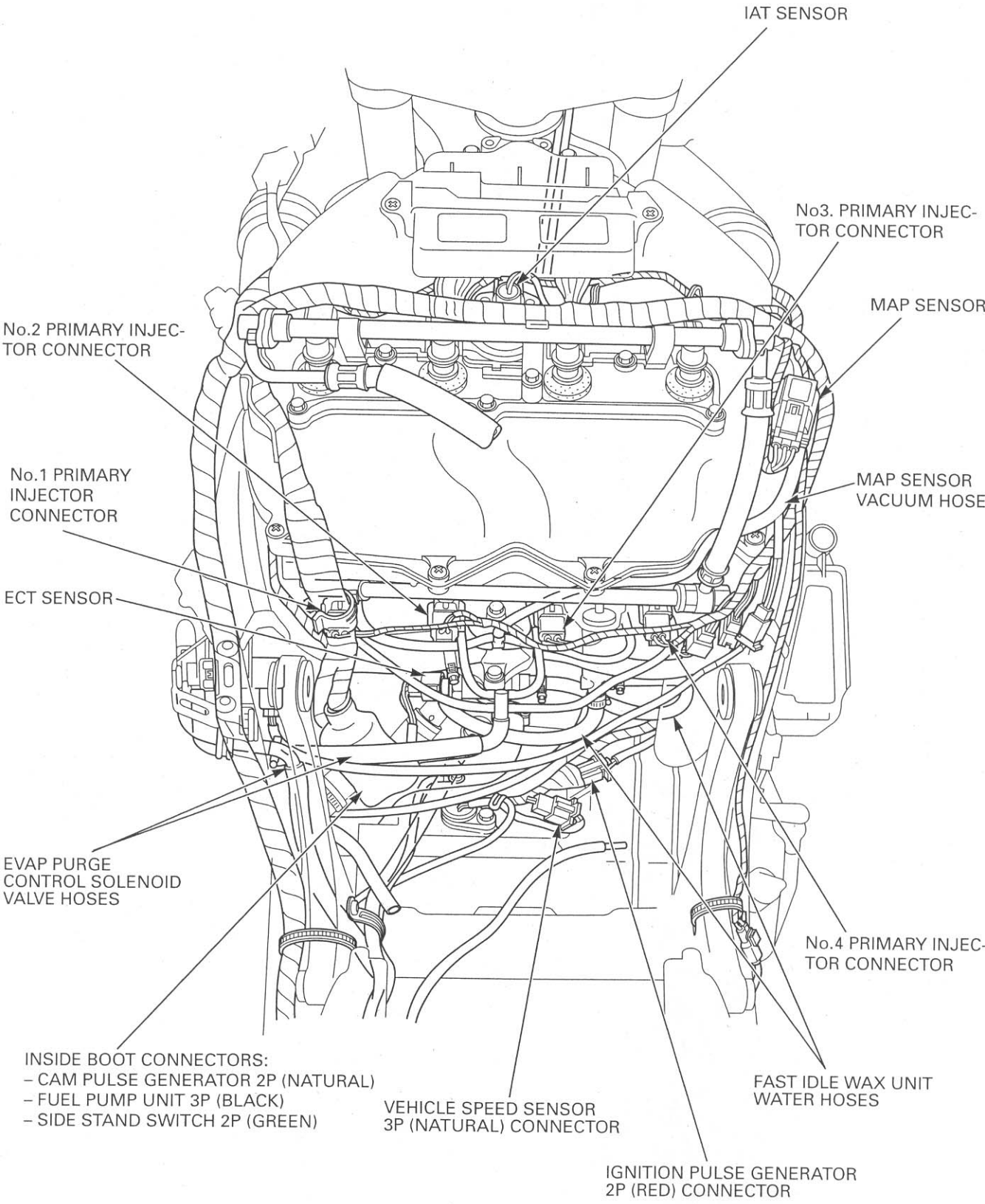

GENERAL INFORMATION

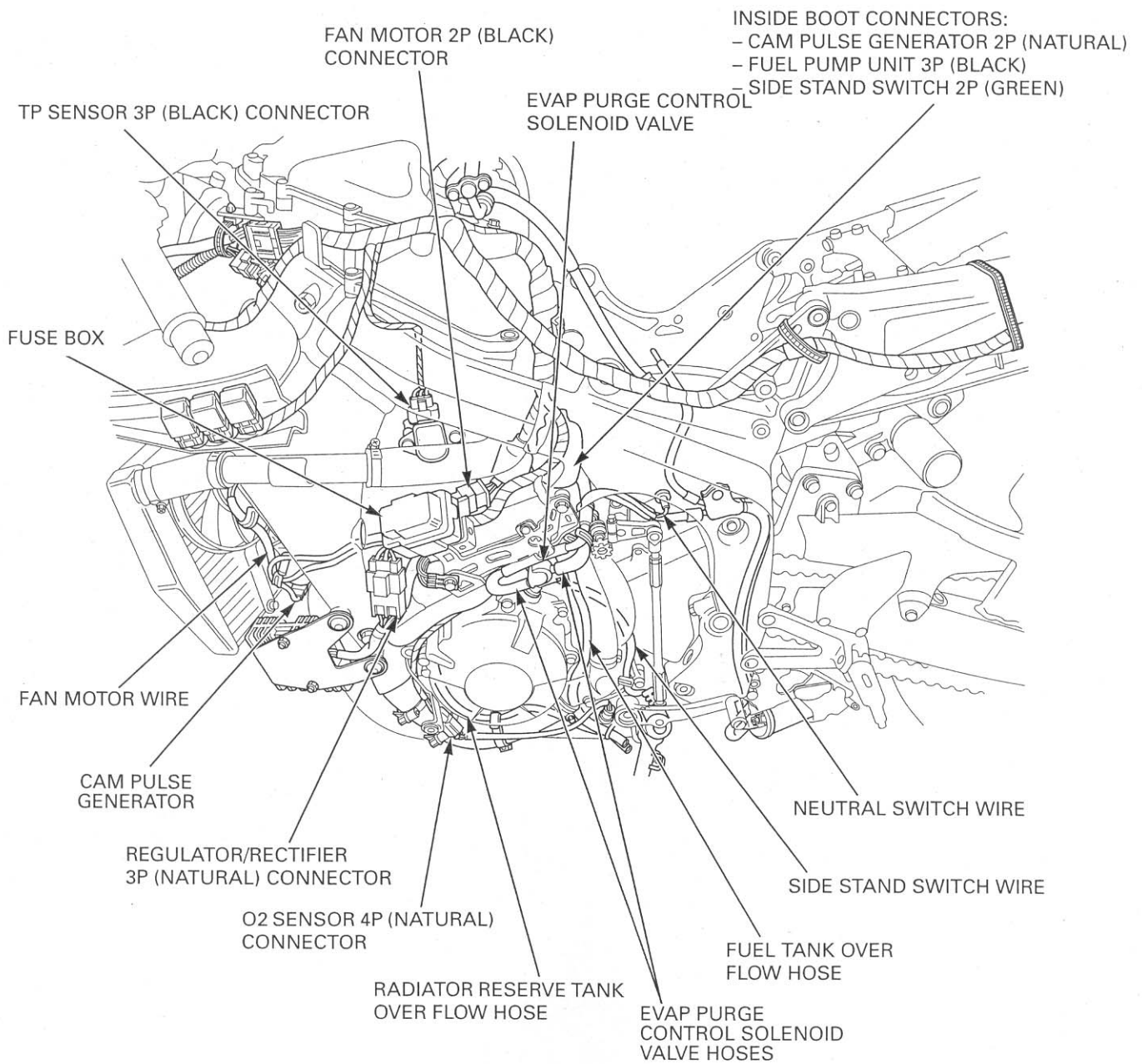

GENERAL INFORMATION

EVAP PURGE CONTROL SOLENOID VALVE

FUEL TANK AIR VENT HOSE

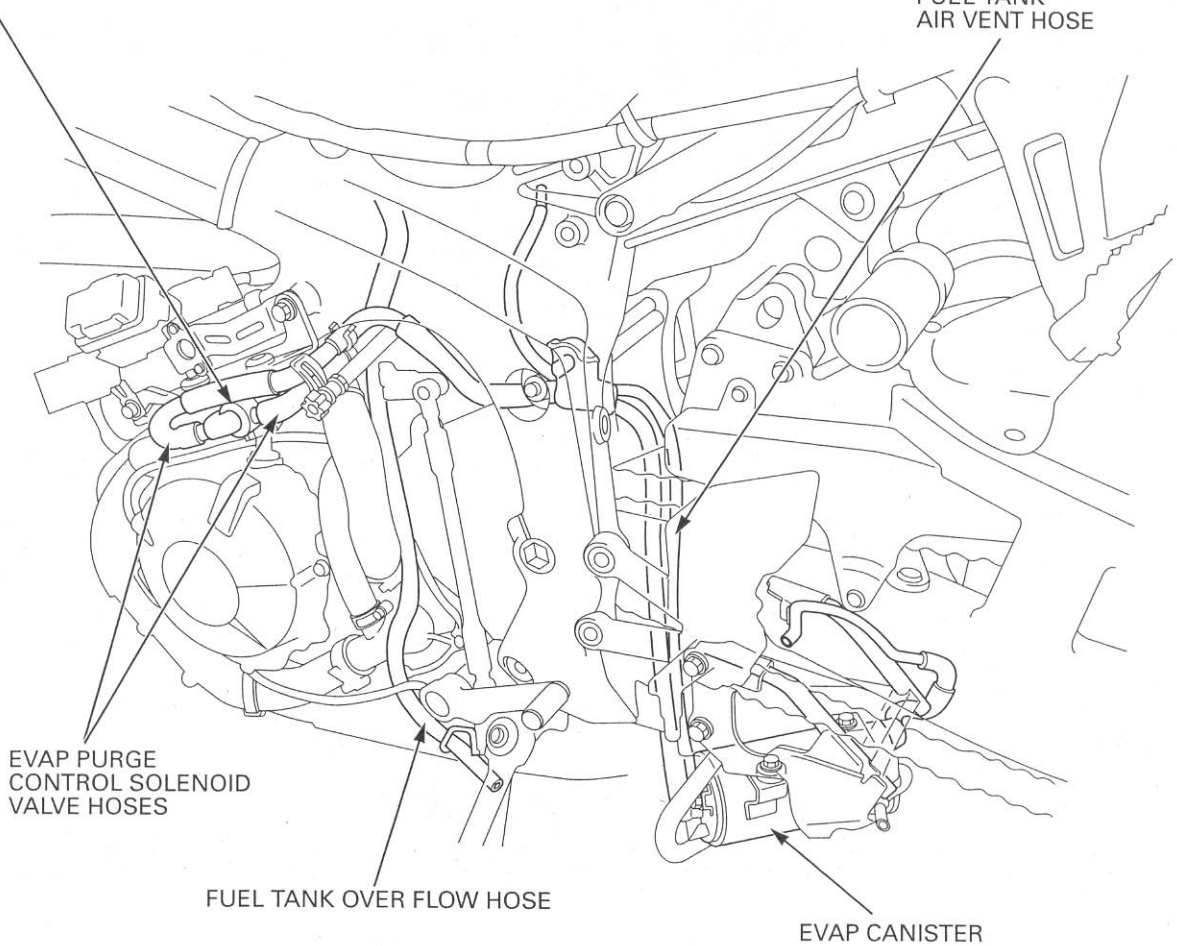

EVAP PURGE CONTROL SOLENOID VALVE

FUEL TANK AIR VENT HOSE

EVAP PURGE CONTROL SOLENOID VALVE HOSES

EVAP CANISTER

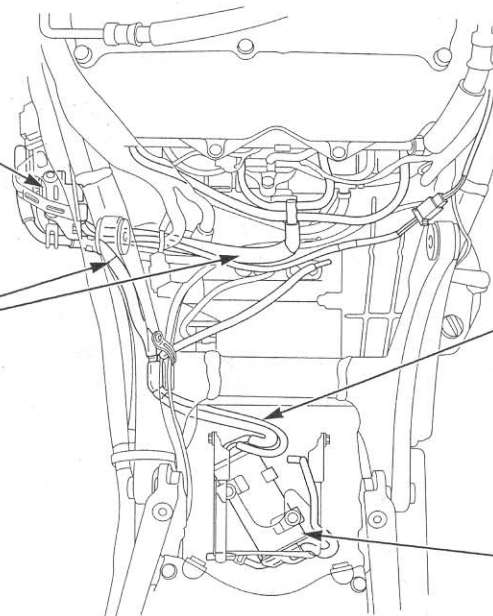

GENERAL INFORMATION

EMISSION CONTROL SYSTEMS

The U.S. Environmental Protection Agency, California Air Resources Board (CARB) and Transport Canada require manufacturers to certify that their motorcycles comply with applicable exhaust emissions standards during their useful life. When operated and maintained according to the instructions provided, and that motorcycles built after January 1, 1983 comply with applicable noise emission standards for one year or 6,000 km (3,730 miles) after the time of sale to the ultimate purchaser, when operated and maintained according to the instructions provided. Compliance with the terms of the Distributor's Limited Warranty for Honda Motorcycle Emission Control Systems is necessary in order to keep the emissions system warranty in effect.

SOURCE OF EMISSIONS

The combustion process produces carbon monoxide and hydrocarbons. Control of hydrocarbons is very important because, under certain conditions, they react to form photochemical smog when subject to sunlight. Carbon monoxide does not react in the same way, but it is toxic.

Honda Motor Co., Ltd. utilizes lean injection settings as well as other systems, to reduce carbon monoxide and hydrocarbons.

CRANKCASE EMISSION CONTROL SYSTEM

The engine is equipped with a closed crankcase system to prevent discharging crankcase emissions into the atmosphere. Blow-by gas is returned to the combustion chamber through the air cleaner and throttle body.

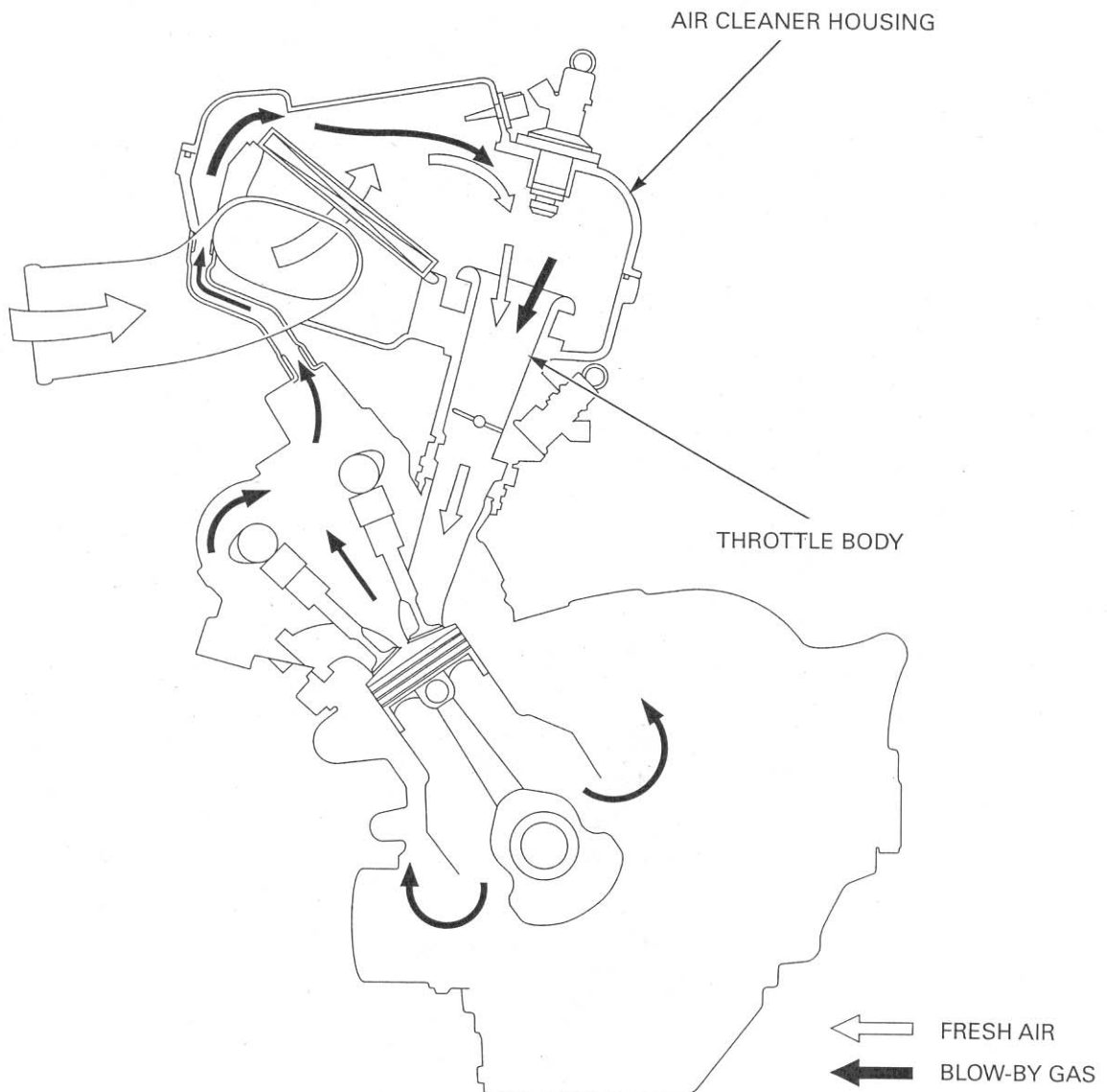

GENERAL INFORMATION

EXHAUST EMISSION CONTROL SYSTEM (SECONDARY AIR SUPPLY SYSTEM)

The exhaust emission control system is composed of a lean fuel injection setting, and no adjustments should be made except idle speed adjustment with the throttle stop screw. The exhaust emission control system is separate from the crank case emission control system.

The exhaust emission control system consists of a secondary air supply system which introduces filtered air into the exhaust gases in the exhaust port. Fresh air is drawn into the exhaust port by the function of the PAIR (Pulse Secondary Air Injection) control valve.

This charge of fresh air promotes burning of the unburned exhaust gases and changes a considerable amount of hydrocarbons and carbon monoxide into relatively harmless carbon dioxide and water vapor.

The reed valve prevents reverse air flow through the system. The PAIR control valve is operated by the solenoid valve. The solenoid valve is controlled by the PGM-FI unit, and the fresh air passage is opened/closed according to running conditions (ECT/IAT/TP/MAP sensor and engine revolution).

No adjustments to the secondary air supply system should be made, although periodic inspection of the components is recommended.

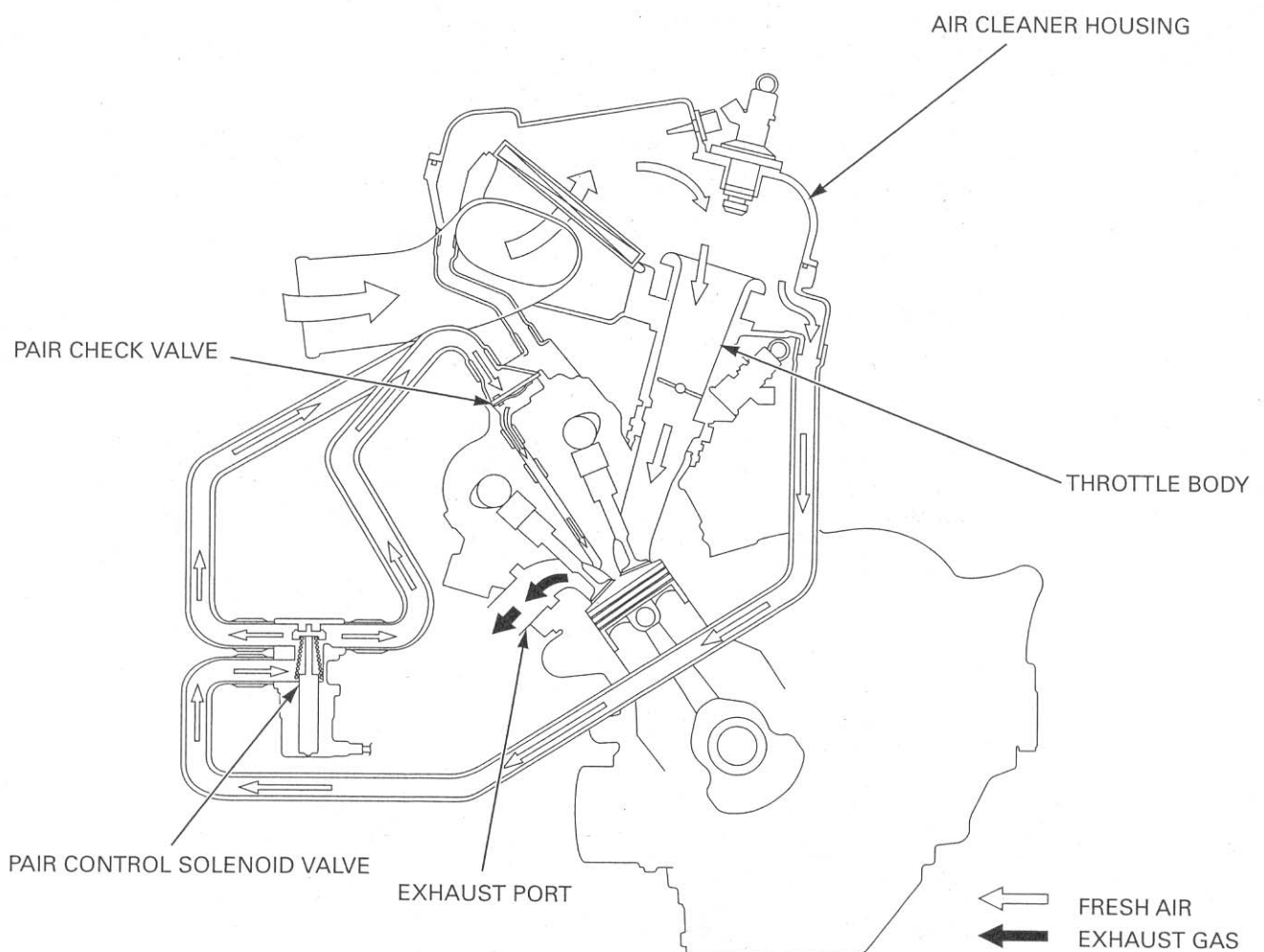

California type only:

The California type is equipped with two three-way warm-up catalytic converters, a three-way catalytic converter, and a heated oxygen sensor.

The three-way catalytic converters are in the exhaust system. Through chemical reactions, they convert HC, CO, and NO_x in the engine's exhaust to carbon dioxide (CO₂), dinitrogen (N₂), and water vapor.

No adjustment to these systems should be made although periodic inspection of the components is recommended.

GENERAL INFORMATION

EVAPORATIVE EMISSION CONTROL SYSTEM (CALIFORNIA TYPE ONLY)

This model complies with CARB evaporative emission requirements.

Fuel vapor from the fuel tank is routed into the evaporative emission (EVAP) canister where it is absorbed and stored while the engine is stopped. When the engine is running and the evaporative emission (EVAP) purge control solenoid valve is open, fuel vapor in the EVAP canister is drawn into the engine through the throttle body.

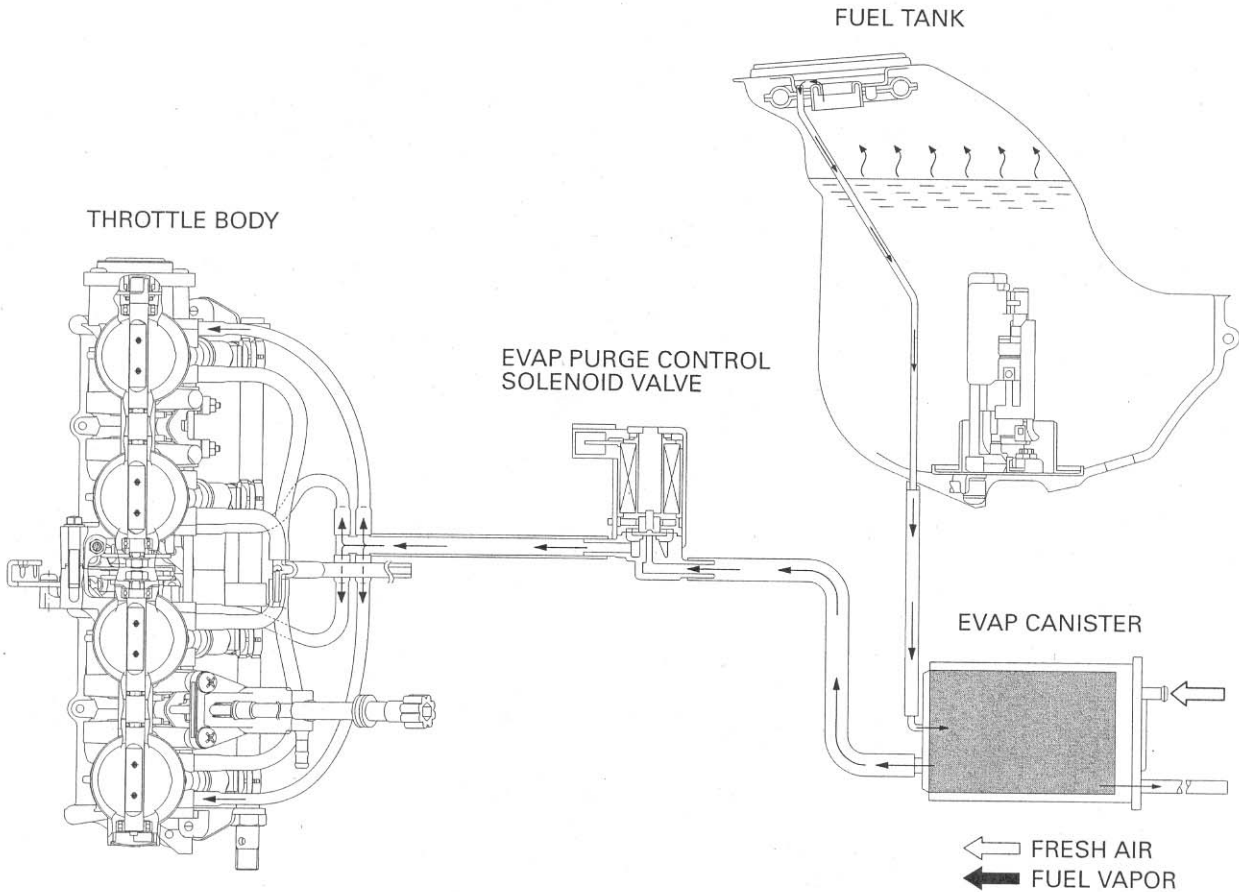

NOISE EMISSION CONTROL SYSTEM

TAMPERING WITH THE NOISE CONTROL SYSTEM IS PROHIBITED: U.S. Federal law prohibits, or Canadian provincial law prohibits the following acts or the causing there of: (1) The removal or rendering inoperative by any person, other than for the purposes of maintenance, repair or replacement, of any device or element of design incorporated into any vehicle for the purpose of noise control prior to its sale or delivery to the ultimate customer or while it is in use; or (2) the use of any vehicle after such device or element of design has been removed or rendered inoperative by any person.

AMONG THOSE ACTS PRESUMED TO CONSTITUTE TAMPERING ARE THE ACTS LISTED BELOW:

1. Removal of, or puncturing of the muffler, baffles, header pipes or any other component which conducts exhaust gases.
2. Removal of, or puncturing of any part of the intake system.
3. Lack of proper maintenance.
4. Replacing any moving parts of the vehicle, or parts of the exhaust or intake system, with parts other than those specified by the manufacturer.

EMISSION CONTROL INFORMATION LABELS (U.S.A. only)

An Emission Control Information Label is located on the as shown. The fuel tank must be opened to read it. Refer to page 6-61 fuel tank opening.

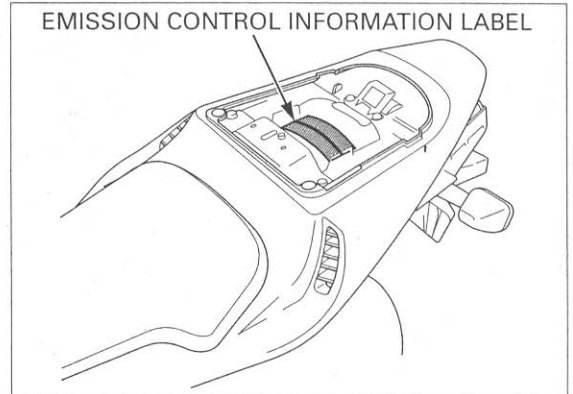

VACUUM HOSE ROUTING DIAGRAM LABEL (CALIFORNIA TYPE ONLY)

The Vacuum Hose Routing Diagram Label is on the air cleaner housing cover as shown. The fuel tank must be opened to read it. Refer to page 6-61 for fuel tank opening.

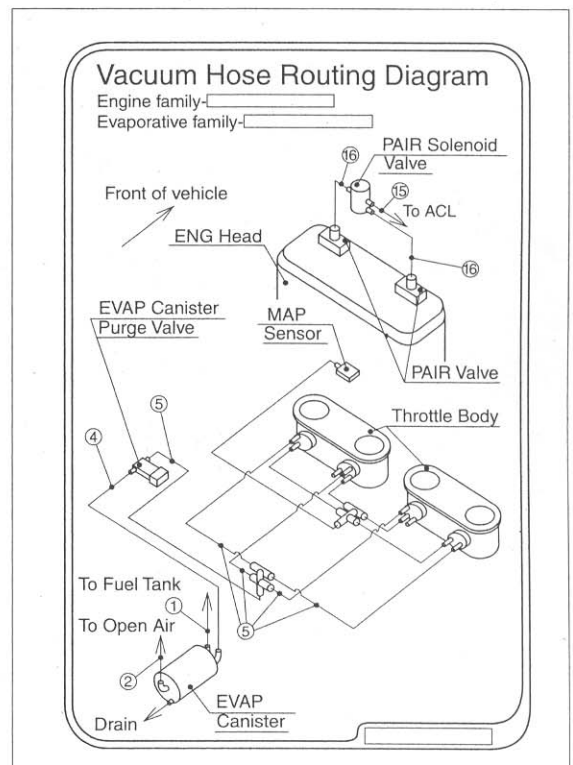
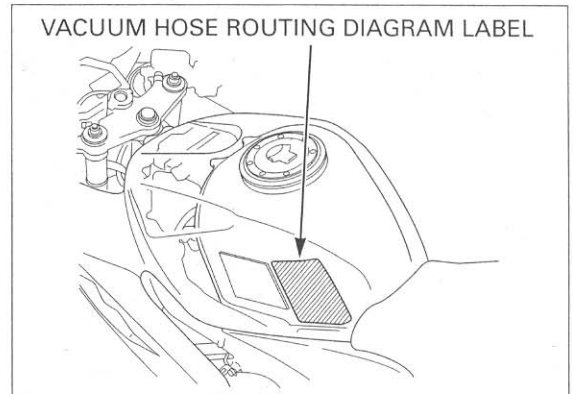

2. TECHNICAL FEATURE

ABSOLUTE PRESSURE FUEL
SUPPLY SYSTEM 2-2

DUAL SEQUENTIAL FUEL INJECTION
SYSTEM (PGM-DSFI)2-3

UNIT PROLINK SUSPENSION.....2-4

TECHNICAL FEATURE

ABSOLUTE PRESSURE FUEL SUPPLY SYSTEM

The fuel delivery system consists of the following components: fuel tank, fuel strainer, fuel pump, fuel filter, internal pressure regulator, fuel delivery hoses, fuel rails and injectors.

This system is equipped with the absolute fuel pressure. There is no external fuel return hose or vacuum pressure regulator with this system.

The fuel pressure in the fuel delivery system is regulated by the internal pressure regulator and always kept absolute; 343 kPa (3.5 kgf/cm², 50 psi).

The internal pressure regulator returns the fuel by opening a valve when the fuel pressure increases more than 343 kPa (3.5 kgf/cm², 50 psi).

This system optimizes injection volume by the ECM control.

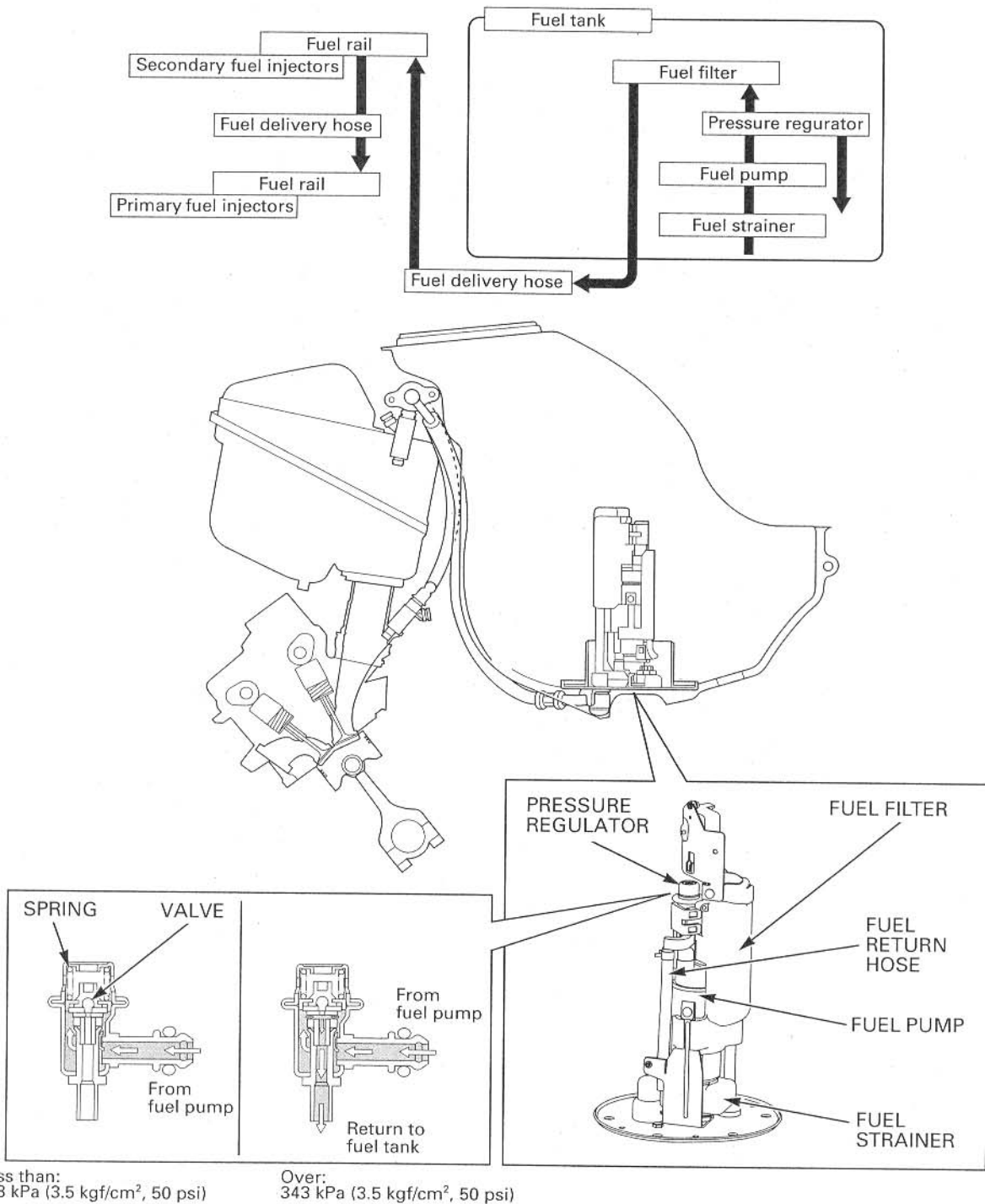

DUAL SEQUENTIAL FUEL INJECTION SYSTEM (PGM-DSFI)

The CBR600RR is equipped with two injectors per cylinder.
 The primary injector is built in the throttle body and the secondary injector is built on the upper air cleaner case.
 Four primary injectors and four upper injectors are connected in series to the fuel delivery hose.
 The ECM controls the injector operation and injection time, according to the signals from each sensor.
 The primary injector operates at all engine speed, both the primary and secondary injector operate at high engine speeds (over 5,500 rpm) and throttle wide opened (over 50°).

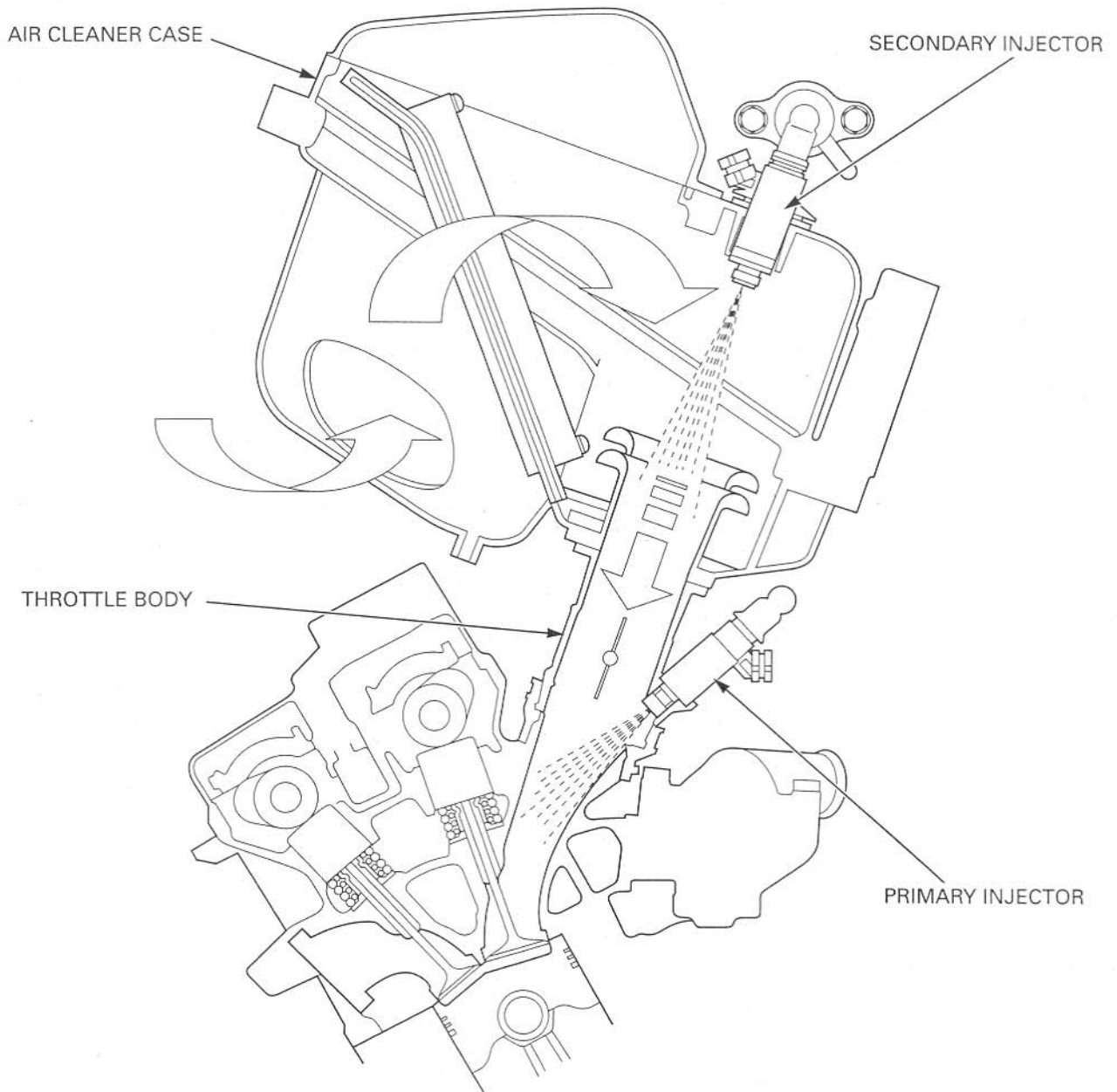

TECHNICAL FEATURE

UNIT PROLINK SUSPENSION

The CBR600RR features the unit pro-link rear suspension which consists of the swingarm, shock link, shock arm, shock absorber and upper mounting bracket.

The rear suspension unit is connected to the frame at the swingarm pivot and link arm, eliminating an upper shock connection to the frame.

The upper part of rear shock absorber is mounted on the upper mounting bracket through the swingarm, therefore the whole rear shock absorber moves in response to rear wheel movement.

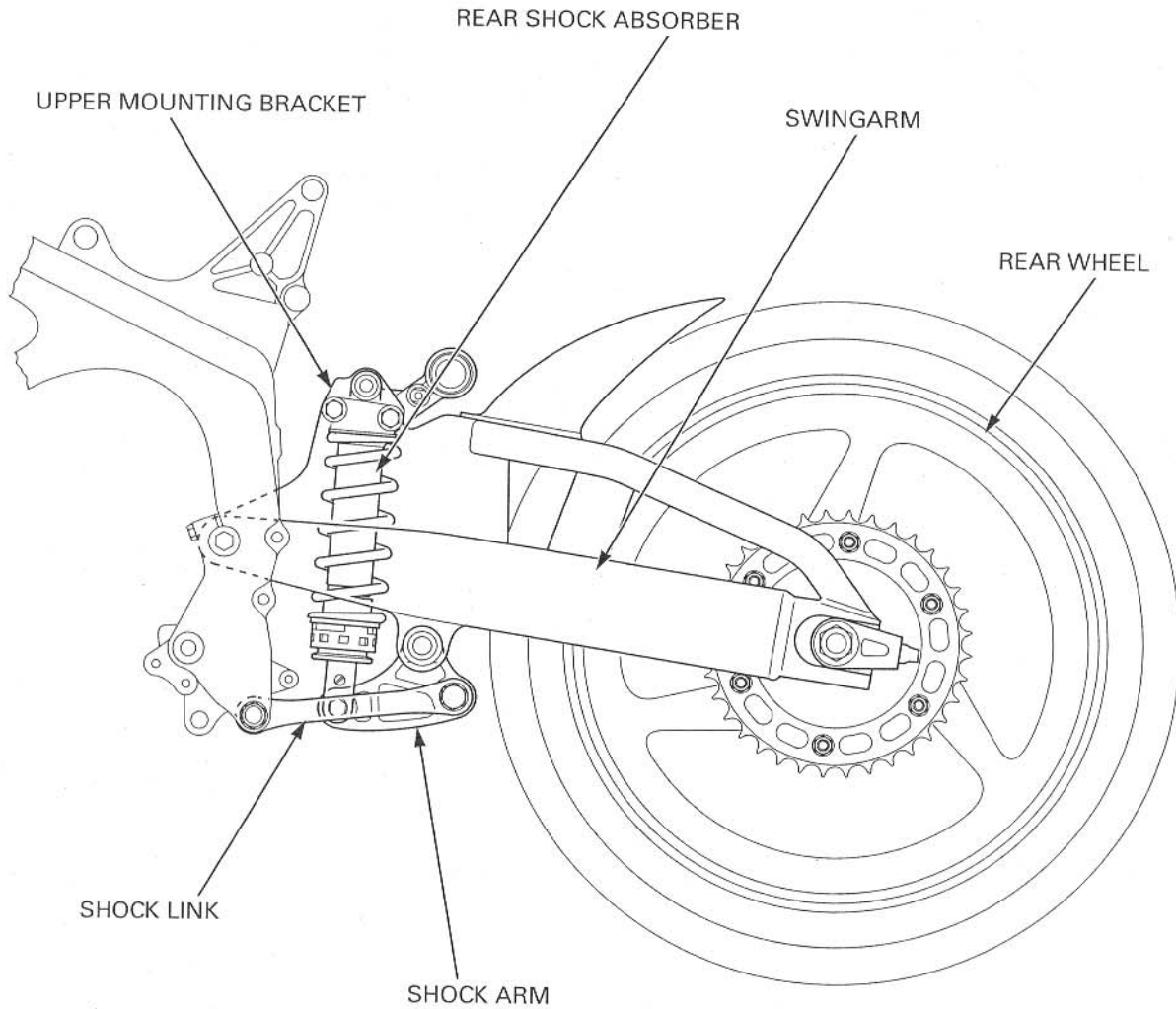

3. FRAME/BODY PANELS/EXHAUST SYSTEM

BODY PANEL LOCATIONS	3-2	AIR DUCT COVERS	3-9
SERVICE INFORMATION	3-3	UPPER COWL	3-9
TROUBLESHOOTING	3-3	FUEL TANK COVER.....	3-15
SEAT	3-4	FRONT FENDER.....	3-15
PASSENGER SEAT.....	3-4	REAR FENDER	3-16
SIDE COVERS	3-4	SEAT RAIL.....	3-18
REAR COWL.....	3-5	MUFFLER	3-20
LOWER COWLS	3-6	EXHAUST PIPE	3-24
MIDDLE COWLS	3-7		

FRAME/BODY PANELS/EXHAUST SYSTEM

BODY PANEL LOCATIONS

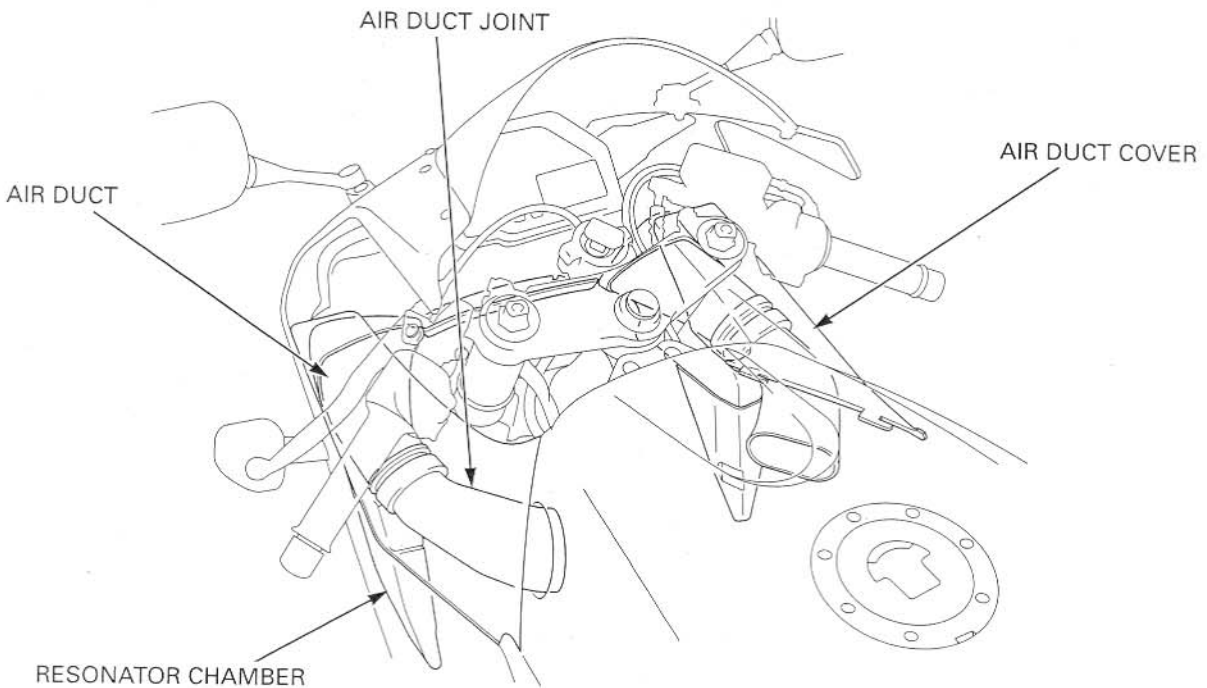
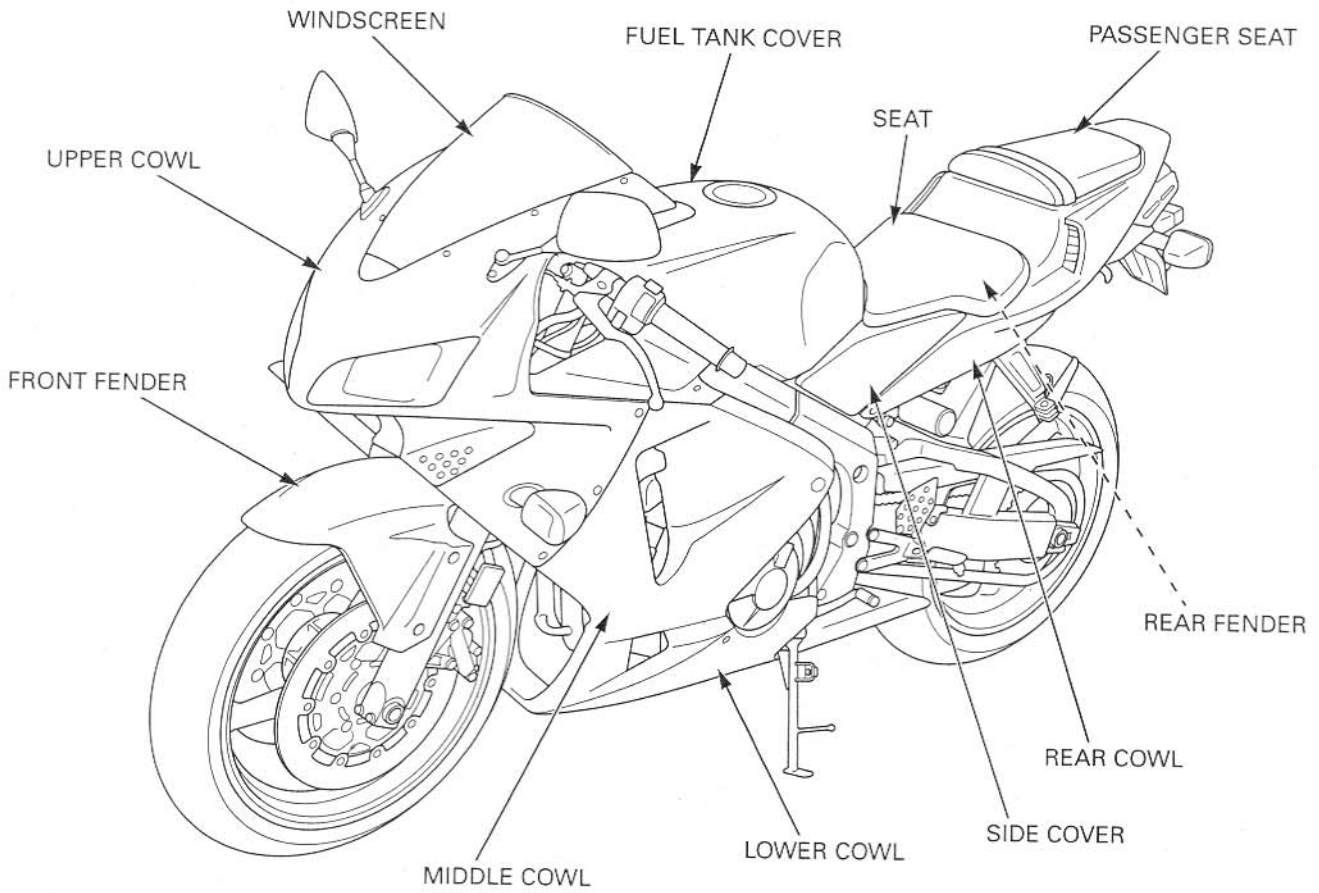

SERVICE INFORMATION

GENERAL

- This section covers removal and installation of the body panels, exhaust system and seat rail.
- Serious burns may result if the exhaust system is not allowed to cool before components are removed or serviced.
- Always replace the exhaust pipe gaskets with a new one after removing the exhaust pipe from the engine.
- When installing the exhaust system, loosely install all of the exhaust pipe fasteners. Always tighten the exhaust clamps first, then tighten the mounting fasteners.
- Always inspect the exhaust system for leaks after installation.

TORQUE VALUES

Lower cowl-to-middle cowl pan screw	1.5 N·m (0.15 kgf·m, 1.1 lbf·ft)
Middle cowl-to-upper cowl pan screw	1.5 N·m (0.15 kgf·m, 1.1 lbf·ft)
Windscreen setting screw	0.5 N·m (0.05 kgf·m, 0.4 lbf·ft)
Front brake hose clamp bolt	12 N·m (1.2 kgf·m, 9 lbf·ft)
Front brake hose 3-way joint bolt	12 N·m (1.2 kgf·m, 9 lbf·ft)
Rear brake reservoir mounting bolt	12 N·m (1.2 kgf·m, 9 lbf·ft)
Seat rail upper mounting flange nut	54 N·m (5.5 kgf·m, 40 lbf·ft)
Seat rail lower mounting flange bolt	44 N·m (4.5 kgf·m, 33 lbf·ft)
Seat rail brace socket bolt	26 N·m (2.7 kgf·m, 20 lbf·ft)
Seat rail assembly flange nut	30 N·m (3.1 kgf·m, 22 lbf·ft)
Exhaust pipe joint flange nut	12 N·m (1.2 kgf·m, 9 lbf·ft)
Muffler band flange bolt	23 N·m (2.3 kgf·m, 17 lbf·ft)
Passenger footpeg bracket socket bolt	26 N·m (2.7 kgf·m, 20 lbf·ft)
O ₂ sensor (California type only)	25 N·m (2.6 kgf·m, 19 lbf·ft)

TROUBLESHOOTING

Excessive exhaust noise

- Broken exhaust system
- Exhaust gas leak

Poor performance

- Deformed exhaust system
- Exhaust gas leak
- Clogged muffler

FRAME/BODY PANELS/EXHAUST SYSTEM

SEAT

REMOVAL

Remove the two seat mounting bolts and collars.

Remove the seat by pulling it backward.

INSTALLATION

Install the seat hooks under the fuel tank rear bracket.

Install the collars and seat mounting bolts.

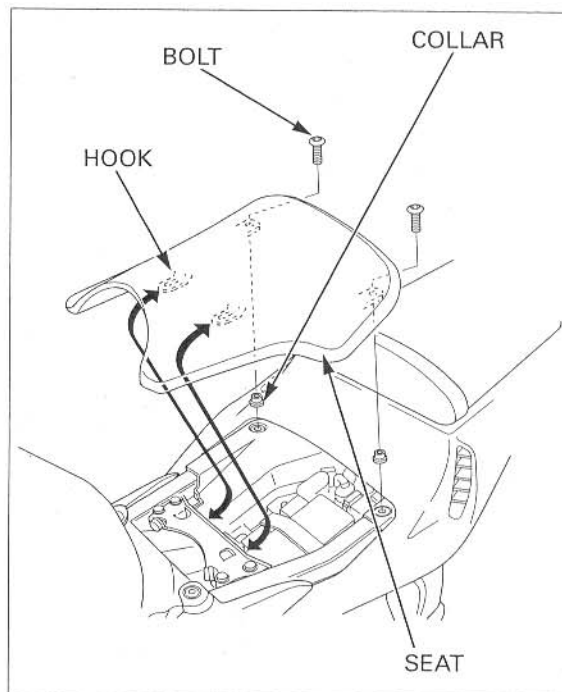

PASSENGER SEAT

REMOVAL/INSTALLATION

Unhook the passenger seat lock using the ignition key.

Remove the passenger seat by pulling it forward.

Install the passenger seat in the reverse order of removal.

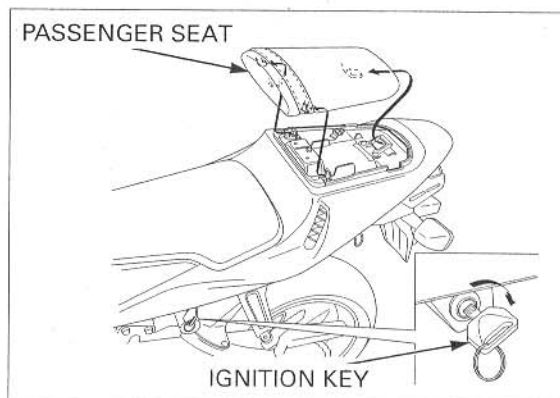

SIDE COVERS

REMOVAL/INSTALLATION

Remove the seat (page 3-4).

Be careful not to damage tab and groove.

Remove the side cover by carefully releasing the bosses from the grommets and slide it forward.

Install the side cover in the reverse order of removal.

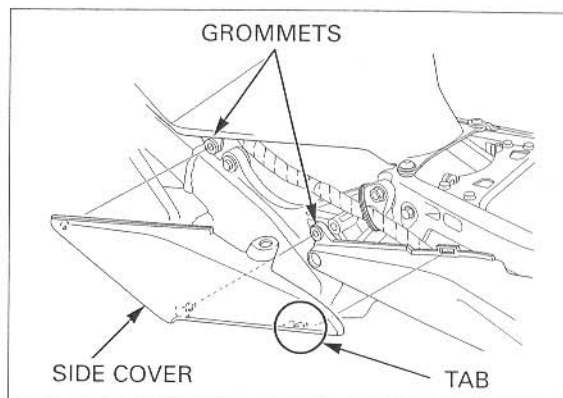

REAR COWL

REMOVAL

Remove the following:

- Seat (page 3-4)
- Passenger seat (page 3-4)
- Side covers (page 3-4)

Remove the four bolts.

Disconnect the stop/tail light connector.

Carefully pull both out sides of the rear cowl, then remove it backward.

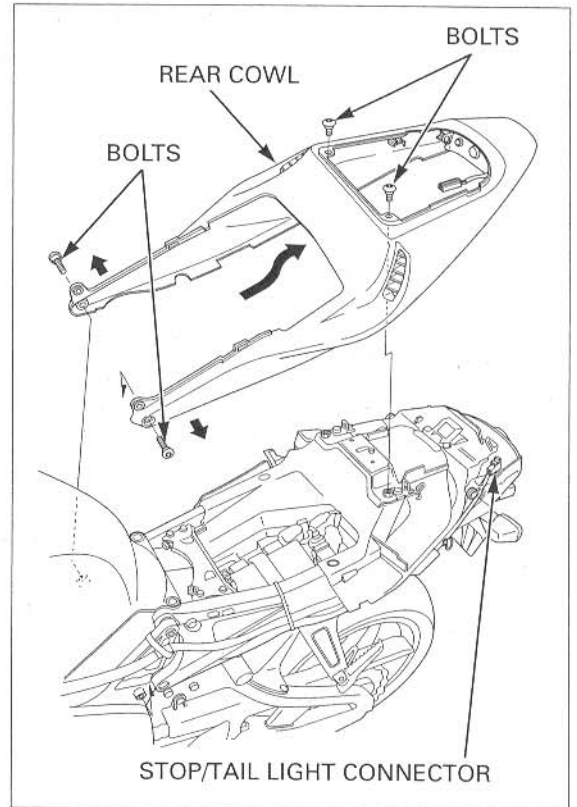

INSTALLATION

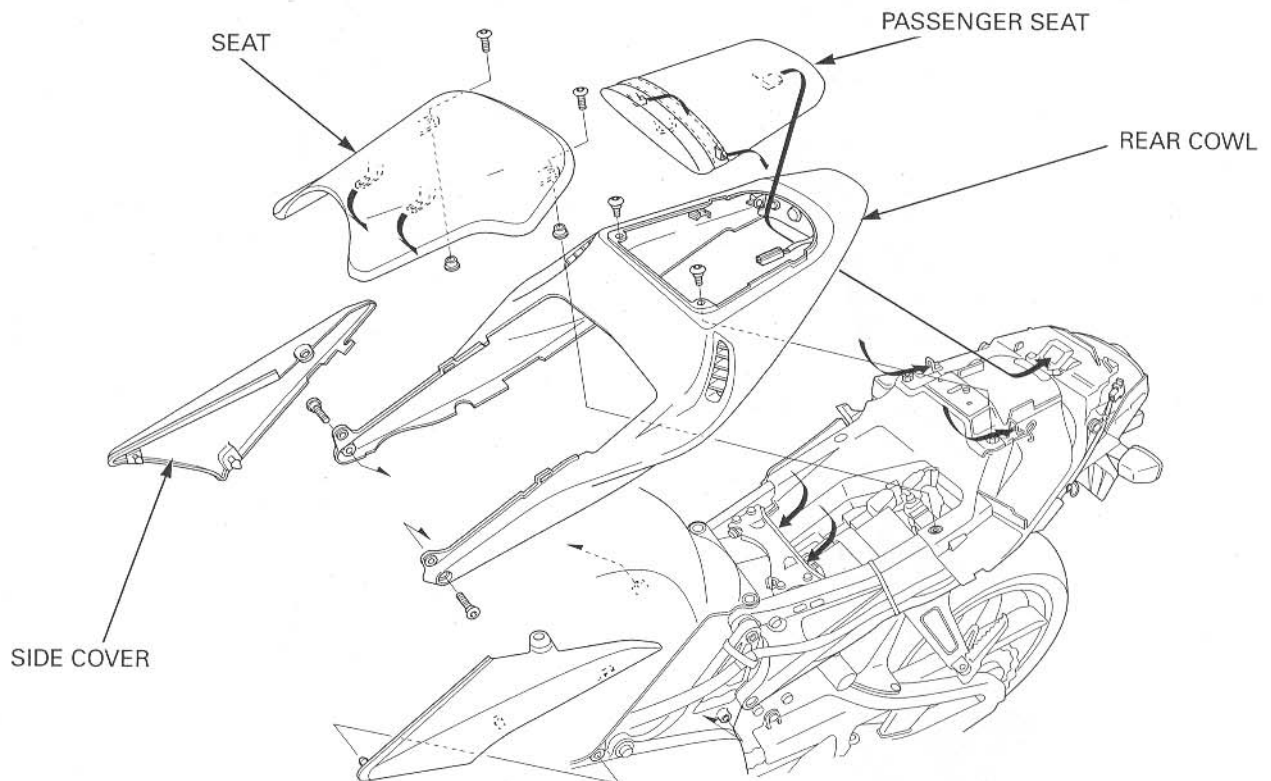

FRAME/BODY PANELS/EXHAUST SYSTEM

Make sure that the mating surfaces of the cowl bottom are seated onto the rear fender properly before tightening the bolts.

Install the rear cowl over the seat rail being careful not to damage the wire harness. Connect the stop/tail light connector.

Install the removed parts in the reverse order of removal.

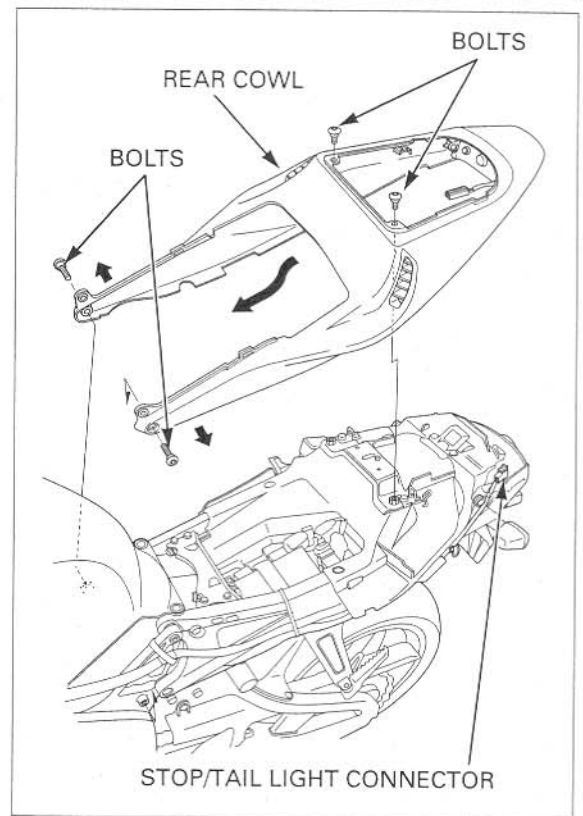

LOWER COWLS

Be careful not to damage the tabs and grooves.

REMOVAL/INSTALLATION

Remove the five trim clips and bolt from the bottom of the lower cowls.

Remove the lower cowl-to-middle cowl pan screws. Remove the lower cowl mounting bolts and then remove the lower cowls by sliding them backward.

Install the lower cowl by aligning the tabs of the lower cowl with the grooves of the middle cowl.

Install and tighten the lower cowl-to-middle cowl pan screws to the specified torque.

TORQUE: 1.5 N·m (0.15 kgf·m, 1.1 lbf·ft)

Install the lower cowl mounting bolts.

Install the five trim clips and bolt from the bottom of the lower cowls.

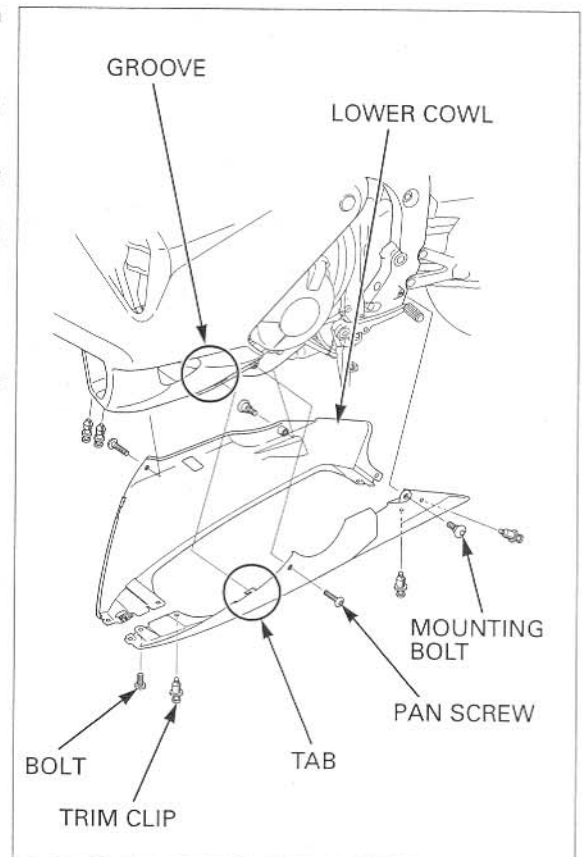

FRAME/BODY PANELS/EXHAUST SYSTEM

California type: Remove the seven trim clips and bolt from the bottom of the lower cowls.

Remove the lower cowl-to-middle cowl pan screws. Remove the lower cowl mounting bolts and then remove the lower cowls by sliding them backward.

Install the lower cowl by aligning the tabs of the lower cowl with the grooves of the middle cowl.

Install and tighten the lower cowl-to-middle cowl pan screws to the specified torque.

TORQUE: 1.5 N·m (0.15 kgf·m, 1.1 lbf·ft)

Install the lower cowl mounting bolts.

Install the seven trim clips and bolt from the bottom of the lower cowls.

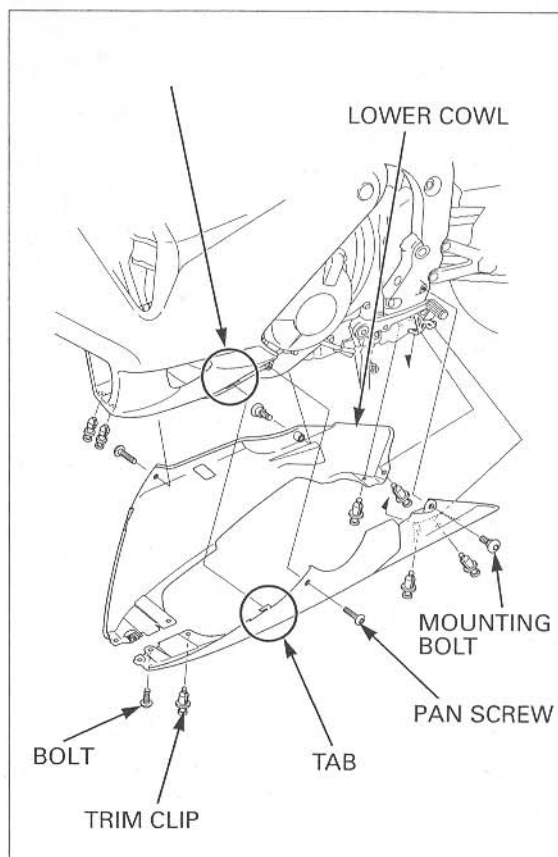

MIDDLE COWLS

REMOVAL

Remove the lower cowls (page 3-6).

Remove the middle cowl-to-upper cowl pan screws and trim clip.

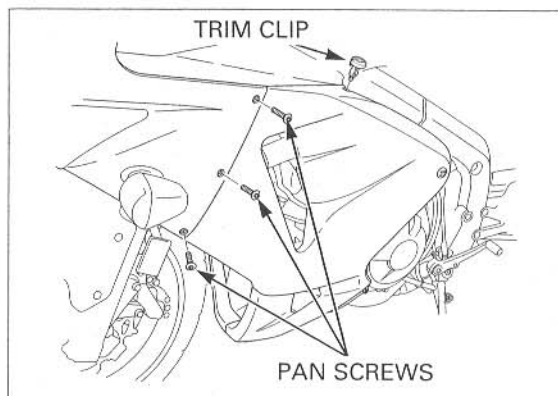

Unlock the lock bolt by turning it counterclockwise and remove the middle cowl.

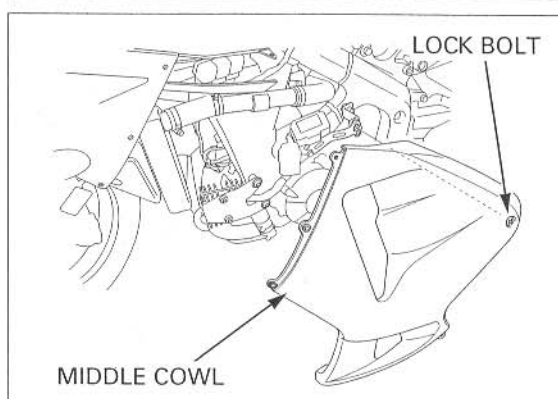

FRAME/BODY PANELS/EXHAUST SYSTEM

INSTALLATION

Except California type:

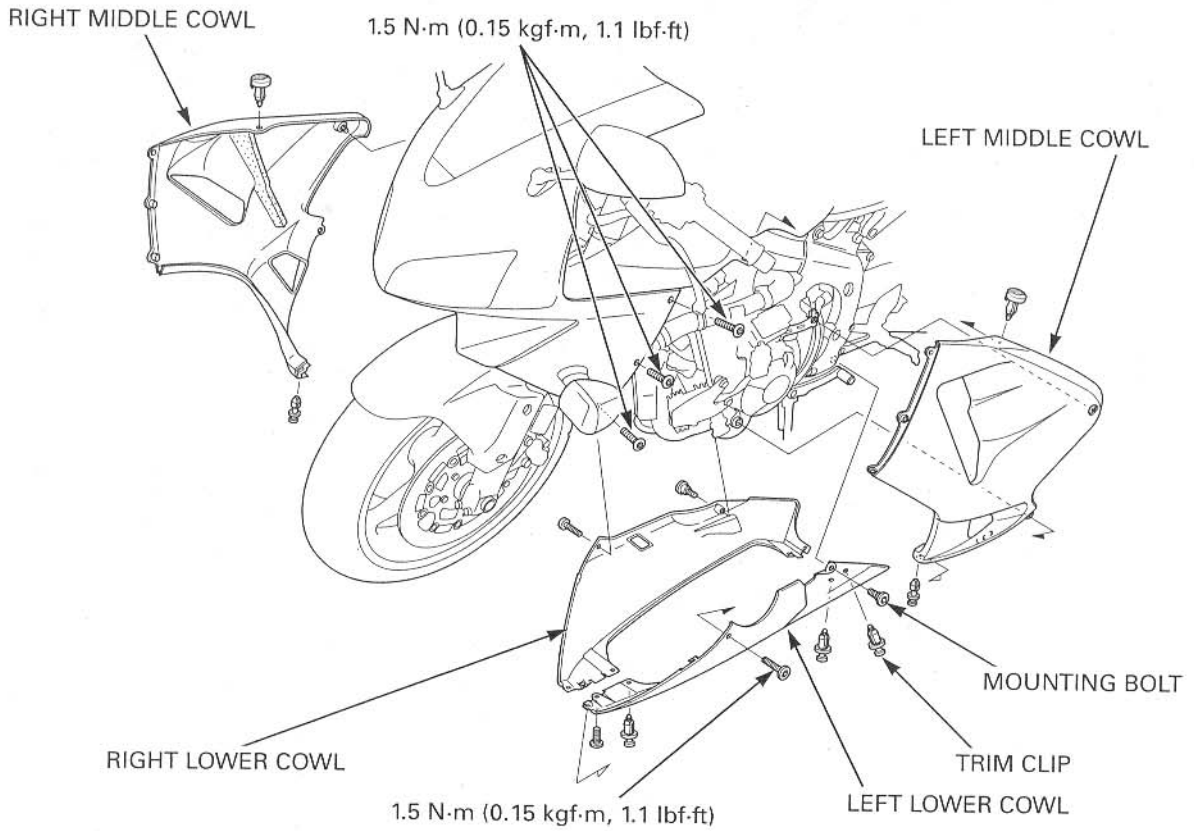

California type:

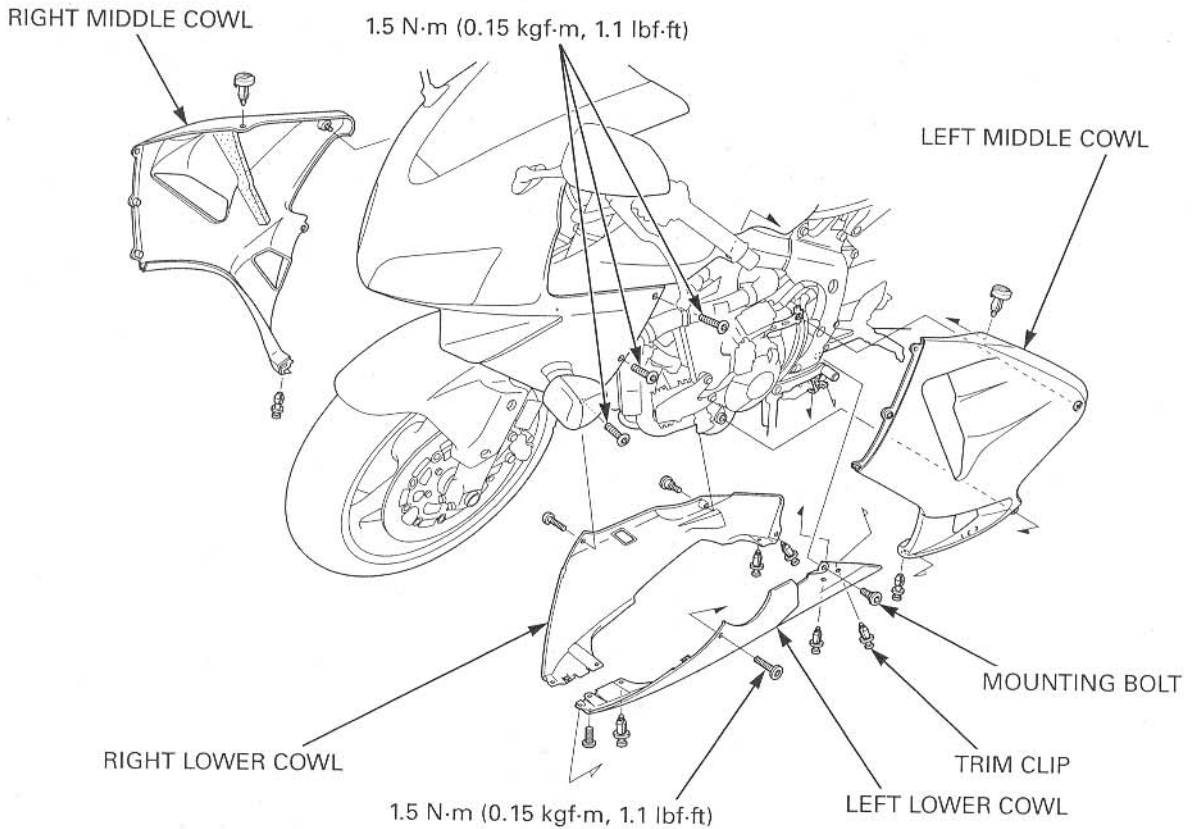

FRAME/BODY PANELS/EXHAUST SYSTEM

Install the middle cowl and lock the lock bolt by turning it clockwise.

Tighten the upper cowl-to-middle cowl pan screws to the specified torque.

TORQUE: 1.5 N·m (0.15 kgf·m, 1.1 lbf·ft)

Install the trim clip.

Install the lower cowls (page 3-6).

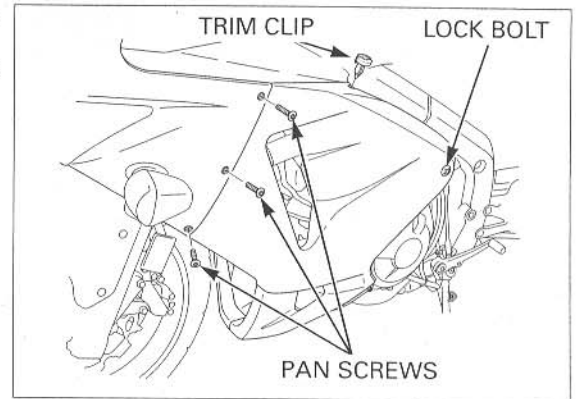

AIR DUCT COVERS

REMOVAL/INSTALLATION

Remove the upper cowl-to-middle cowl pan screw and the two trim clips.

Be careful not to damage the tabs and grooves.

Release the groove of the air duct cover from the pin of the upper cowl and unhook the tabs of the duct cover from the fuel tank cover, then remove the air duct cover.

Install the air duct cover of the reverse order of removal.

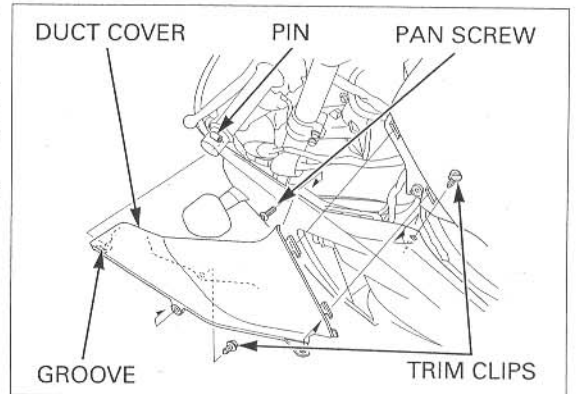

UPPER COWL

REMOVAL

Remove the following:

- Lower cowls (page 3-6)
- Middle cowls (page 3-7)
- Air duct covers (page 3-9)

It is not necessary to remove the windscreen in order to remove the upper cowl.

Remove the screws, plastic and rubber washers, then remove the windscreen.

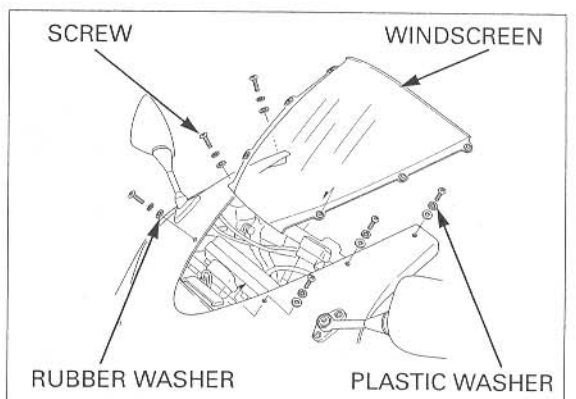

Remove the two trim clips and resonator chambers from the radiator.

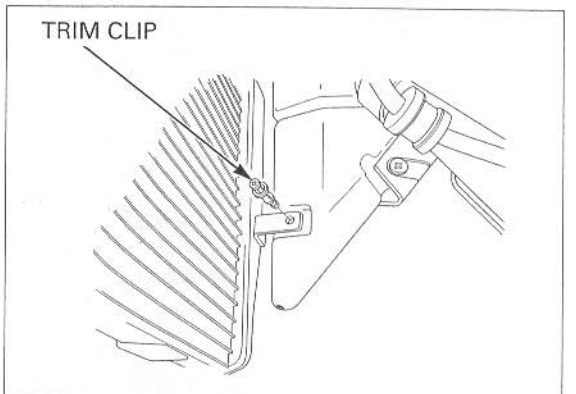

FRAME/BODY PANELS/EXHAUST SYSTEM

Remove the rearview mirror mounting socket bolts and rearview mirrors.

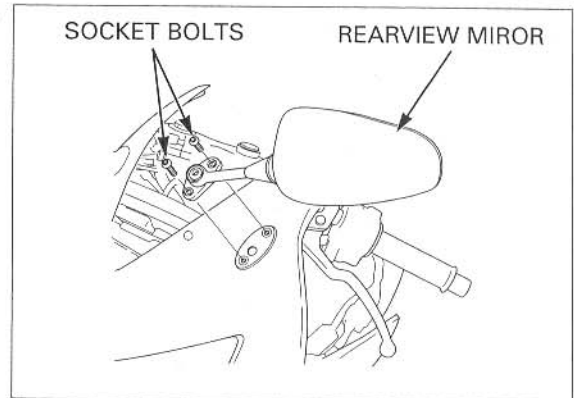

Disconnect the front sub-harness connectors, combination meter multi-connector.

Release the upper cowl off the rearview mirror bolt hole studs and bosses of the upper cowl from the meter stay grommets, then remove the upper cowl assembly.

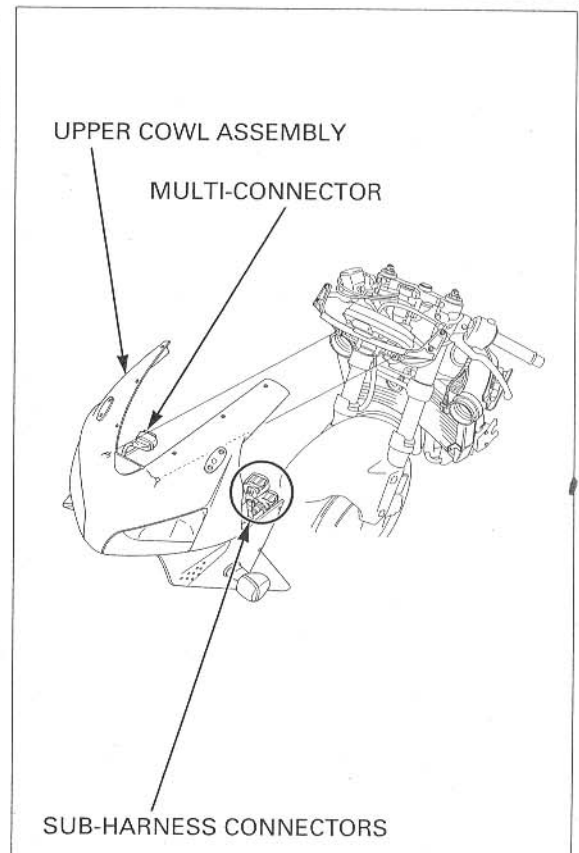

FRAME/BODY PANELS/EXHAUST SYSTEM

Remove the relays and rubber from the left air duct joint.

Remove the air duct joints from the air cleaner housing.

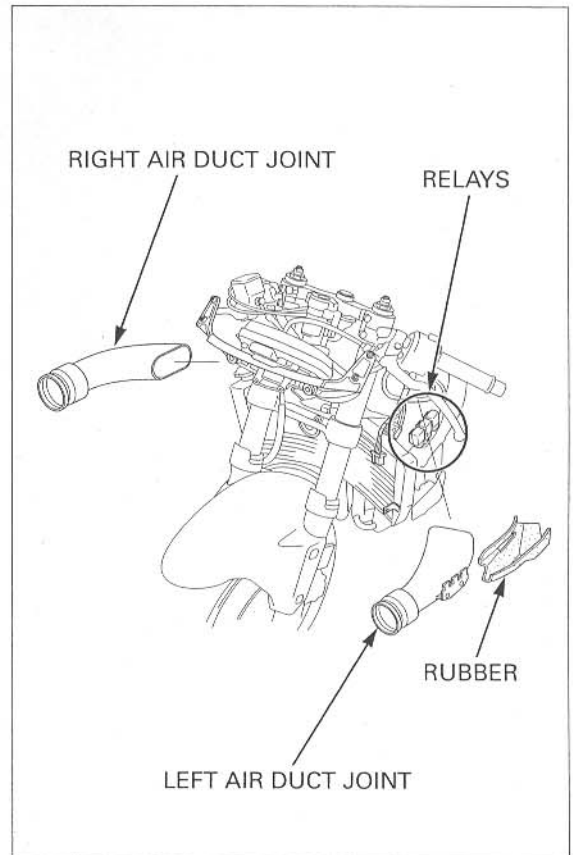

DISASSEMBLY/ASSEMBLY

Remove the trim clips, air ducts and set plate from the upper cowl.

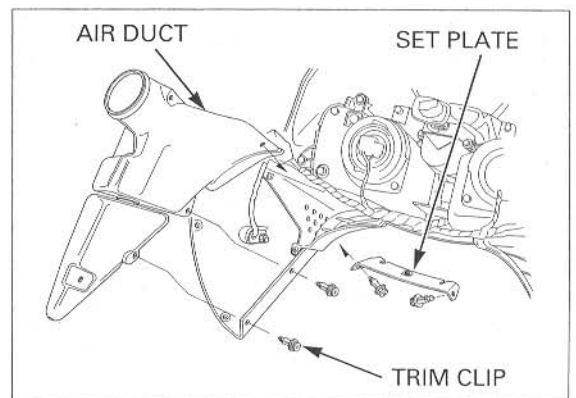

Remove the resonator chamber from the air duct.

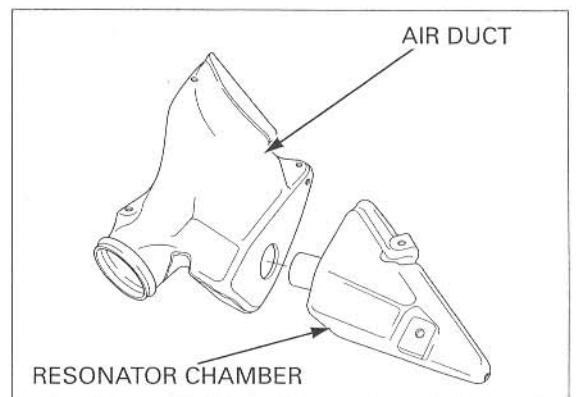

FRAME/BODY PANELS/EXHAUST SYSTEM

Remove the head light unit from the upper cowl (page 20-6).

Remove the screws and front air duct covers from the upper cowl.

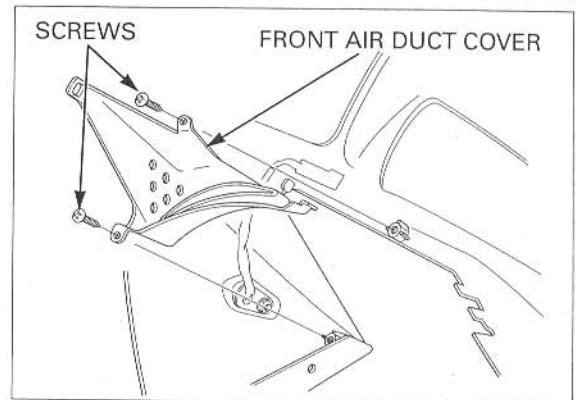

Remove the nuts and setting plates, then remove the front turn signal units.

Assembly is in the reverse order of disassembly.

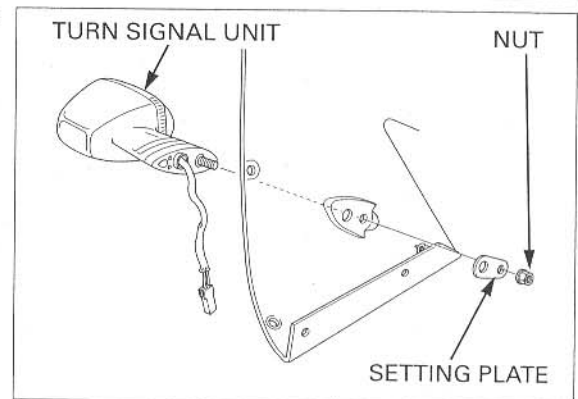

INSTALLATION

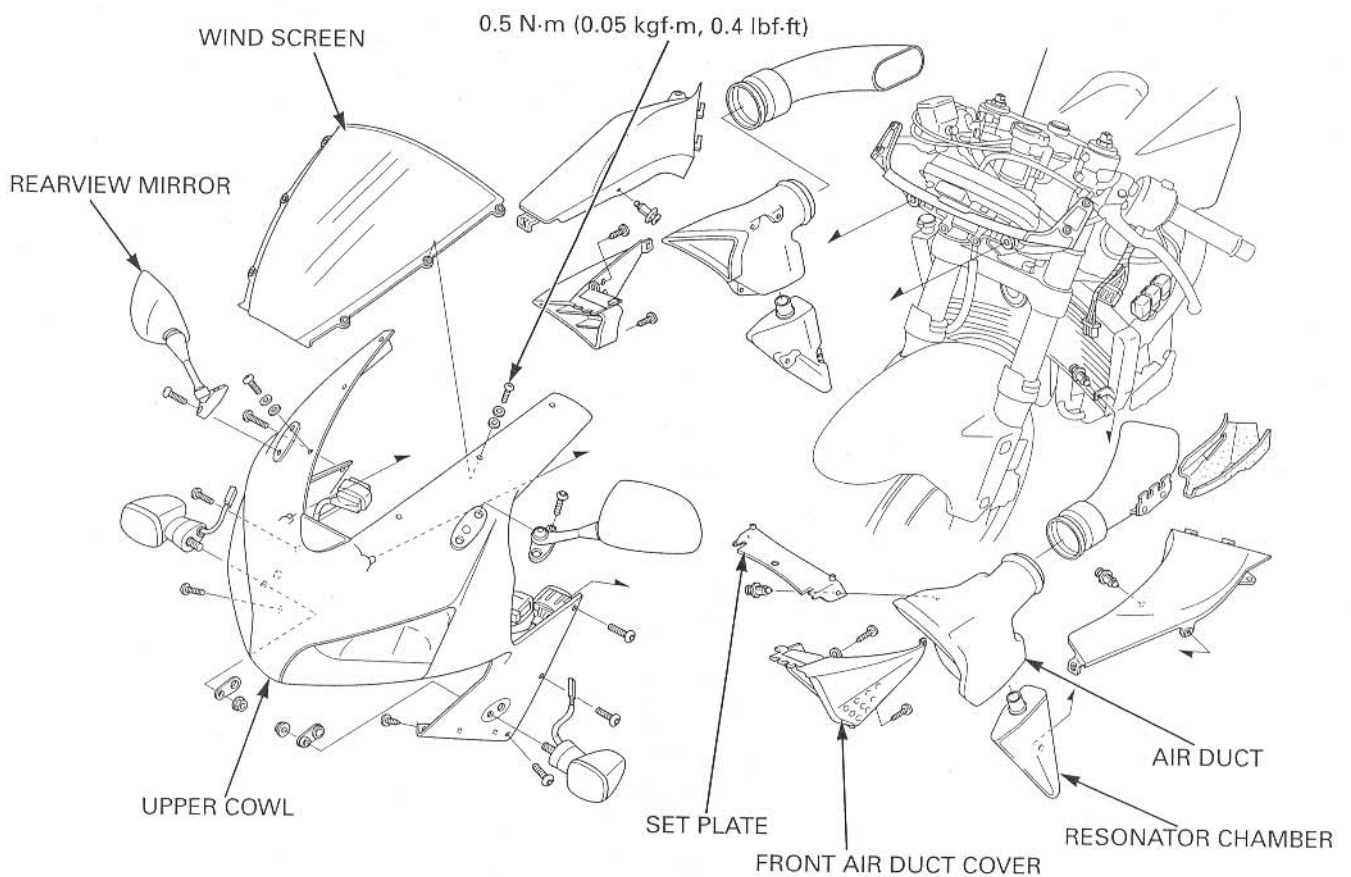

FRAME/BODY PANELS/EXHAUST SYSTEM

Install the air duct joints into the air cleaner housing.

Install the rubber and relays onto the left air duct joint.

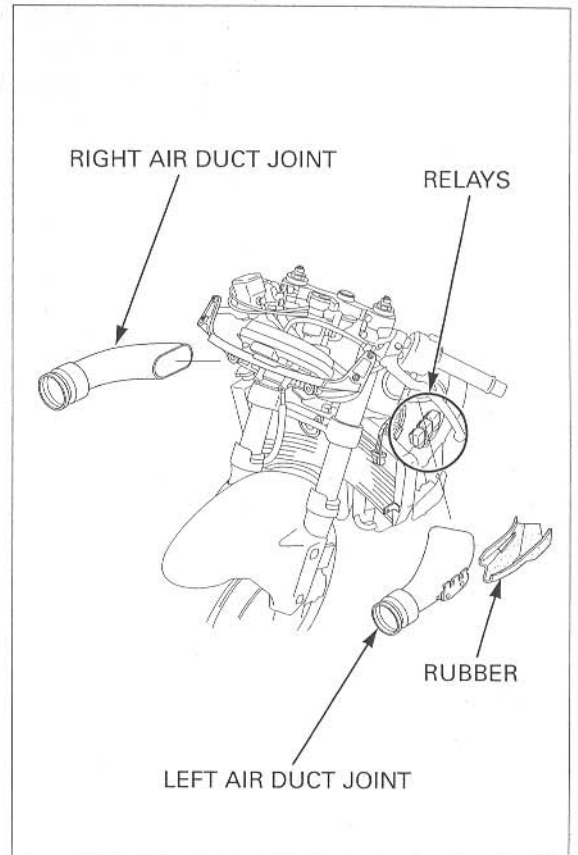

Connect the front sub-harness connectors, combination meter multi-connector.

Install the upper cowl, aligning the bosses with the grommets on the meter stay.

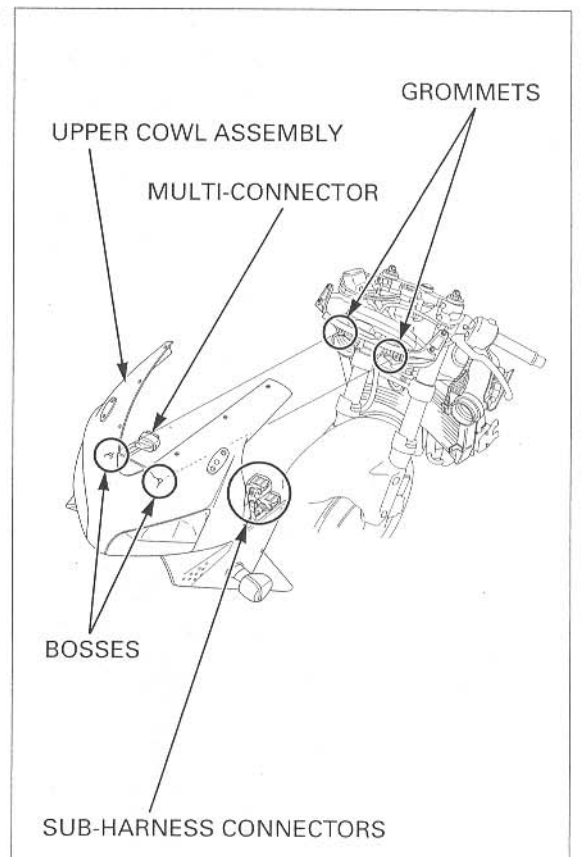

FRAME/BODY PANELS/EXHAUST SYSTEM

Align the rearview mirror bolt hole studs of upper cowl with the rearview mirror stay.

Install the rearview mirror and tighten the socket bolts securely.

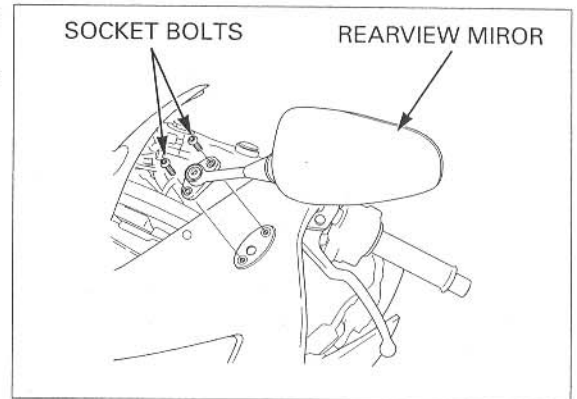

Install the trim clips and resonator chambers onto the radiator.

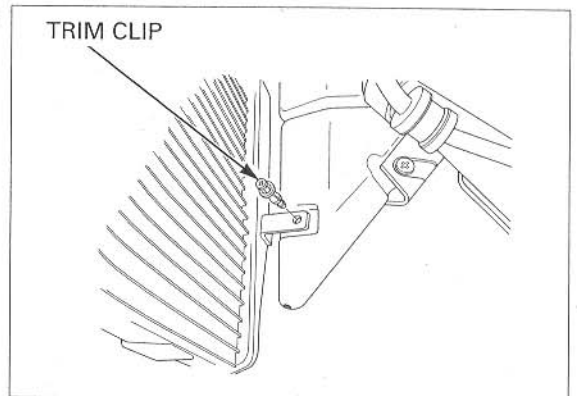

Install the windscreen, then install the rubber and plastic washers and screws. Tighten the screws to the specified torque.

TORQUE: 0.5 N·m (0.05 kgf·m, 0.4 lbf·ft)

Install the following:

- Air duct covers (page 3-9)
- Middle cowls (page 3-7)
- Lower cowls (page 3-6)

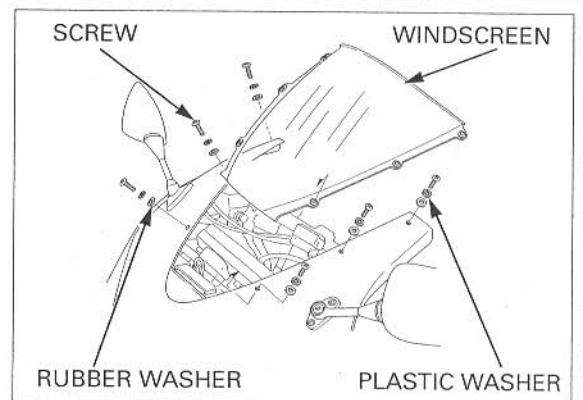

FUEL TANK COVER

REMOVAL/INSTALLATION

Remove the following:

- Seat (page 3-4)
- Side covers (page 3-4)
- Air duct covers (page 3-9)

Remove the six socket bolts, washers and fuel tank cover.

Install the fuel tank cover in the reverse order of removal.

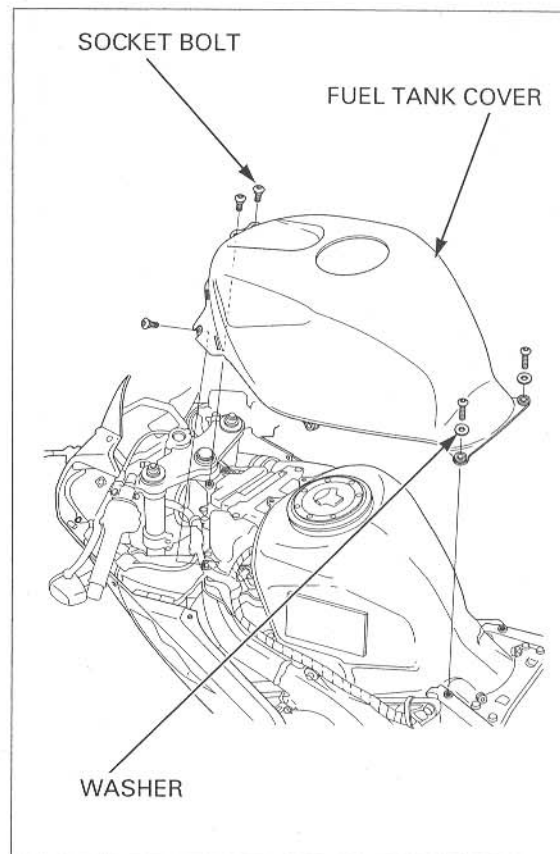

FRONT FENDER

REMOVAL/INSTALLATION

Remove the fork protectors (page 14-19).

Remove the front brake hose 3-way joint bolt, hose clamp bolt and reflectors.

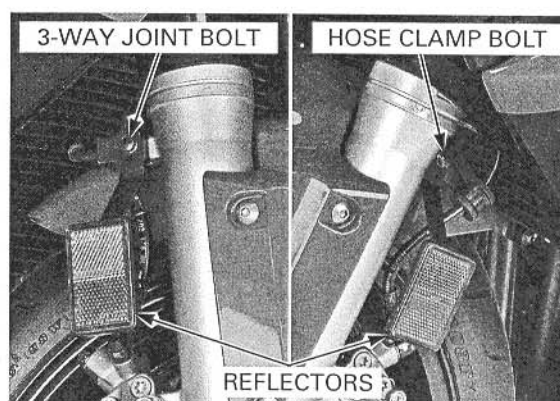

FRAME/BODY PANELS/EXHAUST SYSTEM

Remove the socket bolts and front fender from the forks.

NOTE:

Pull the front fender up, above the sliders and then pull it forward between the fork tubes.

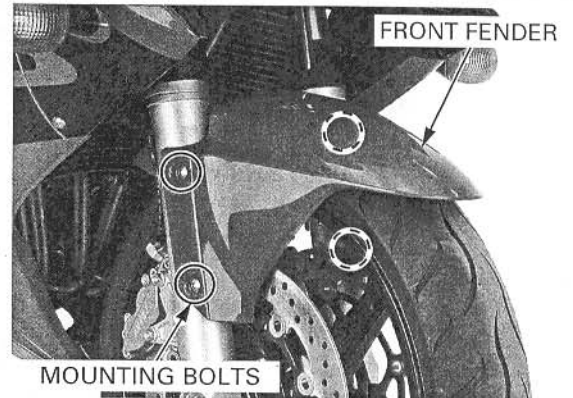

Install the front fender in the reverse order of removal.

TORQUE:

Front brake hose clamp bolt:
12 N·m (1.2 kgf·m, 9 lbf·ft)

Front brake hose 3-way joint bolt:
12 N·m (1.2 kgf·m, 9 lbf·ft)

Install the fork protectors (page 14-26).

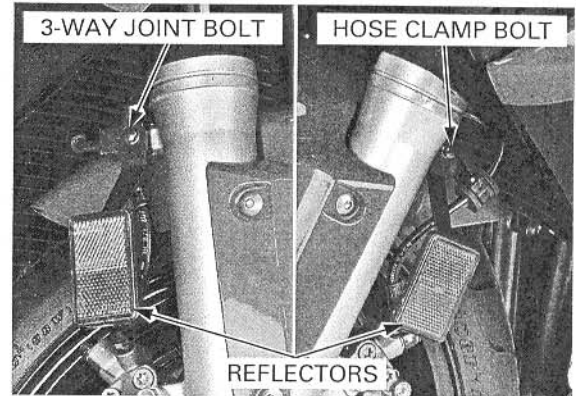

REAR FENDER

REMOVAL

Remove the following:

- Rear cowl (page 3-5)
- Battery (page 17-5)
- Muffler (page 3-20)

Lift and support the fuel tank (page 6-61).

Remove the bolts and passenger seat joint.
Remove the four bolts and seat lock cable stay.

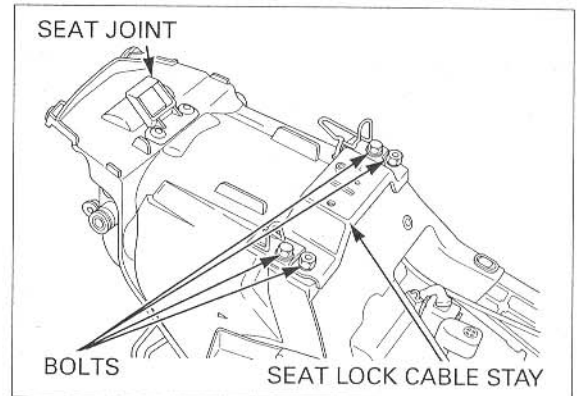

Disconnect the seat lock cable from the cable stay.

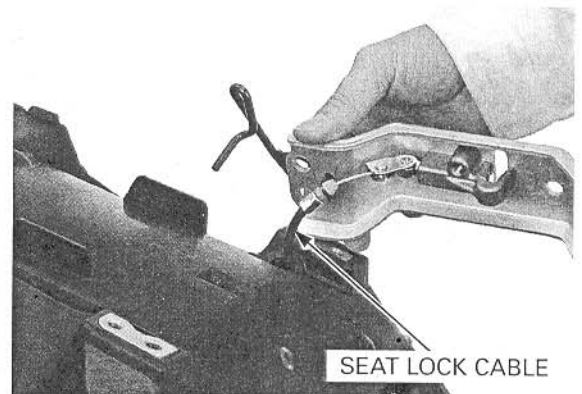

FRAME/BODY PANELS/EXHAUST SYSTEM

Remove the bolts/nuts and seat bracket.

NOTE:

After removing the seat bracket, be careful the angle of the fuel tank.

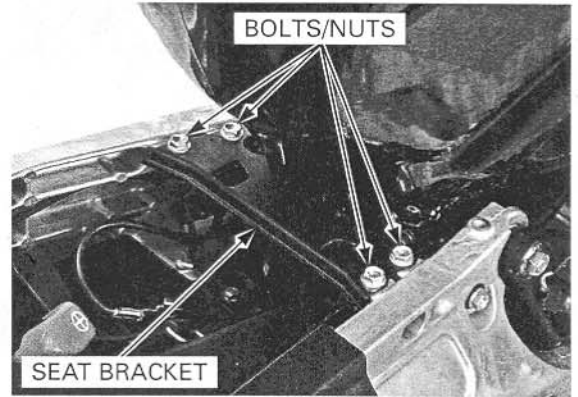

Remove the screw from the rear fender.



Remove the trim clip.

Unhook the rear fender A from the seat rail brace, then remove the rear fender A by pulling up and back.

Remove the seat lock cable guide.

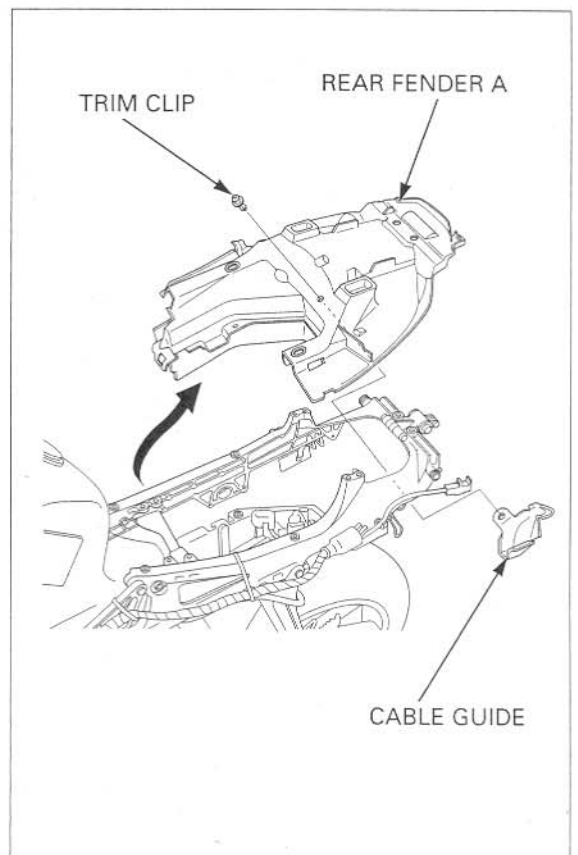

FRAME/BODY PANELS/EXHAUST SYSTEM

INSTALLATION

Installation is in the reverse order of removal.

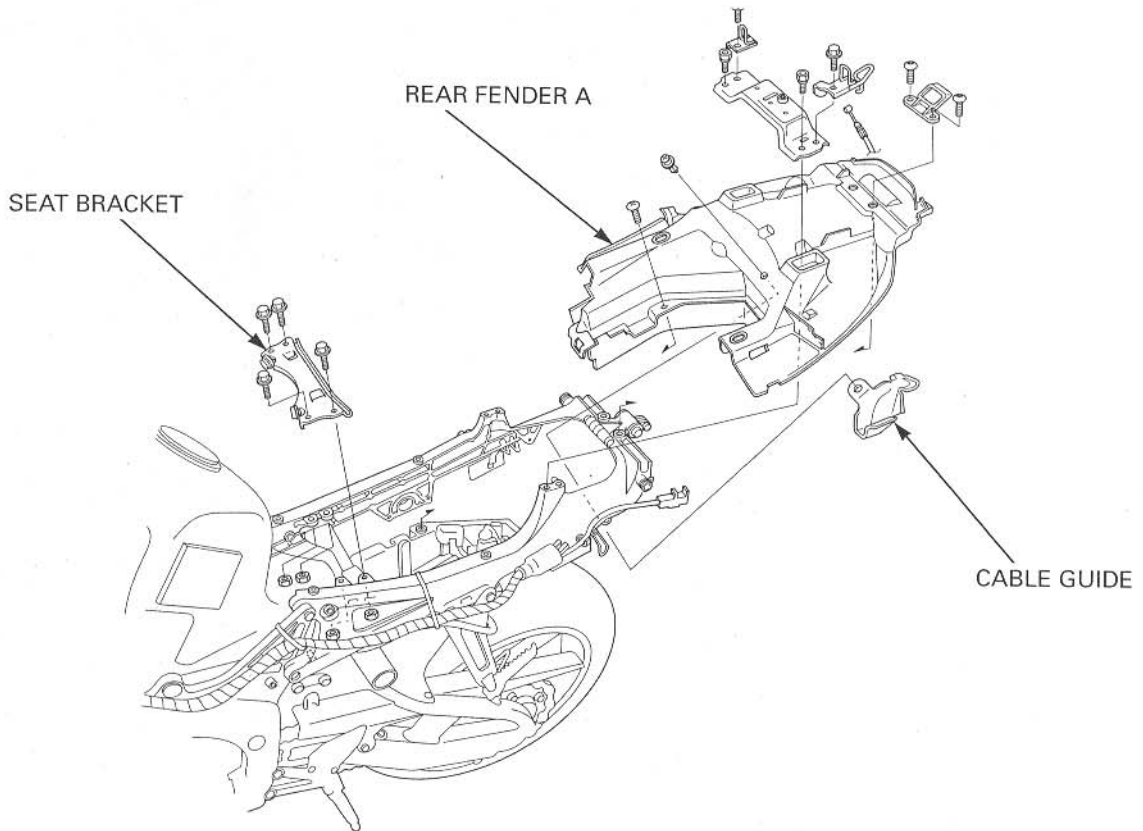

SEAT RAIL

REMOVAL

Remove the following:

- Muffler (page 3-20)
- Rear fender (page 3-16)
- Fuel tank (page 6-61)
- Battery tray (page 17-7)

Loosen the four seat rail brace socket bolts.

Remove the seat rail upper mounting bolts/nuts and lower mounting bolts/collars/nuts, then remove the seat rail.

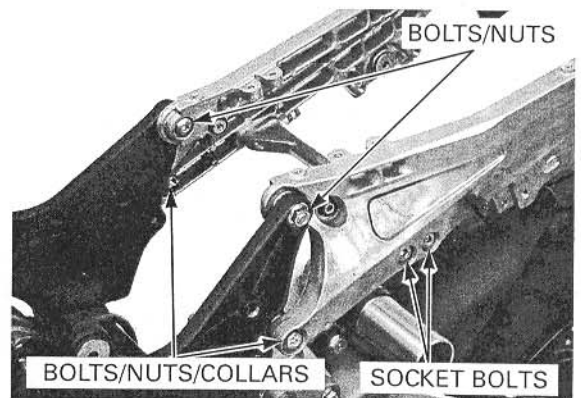

DISASSEMBLY/ASSEMBLY

Remove the four seat rail brace socket bolts and seat rail brace.

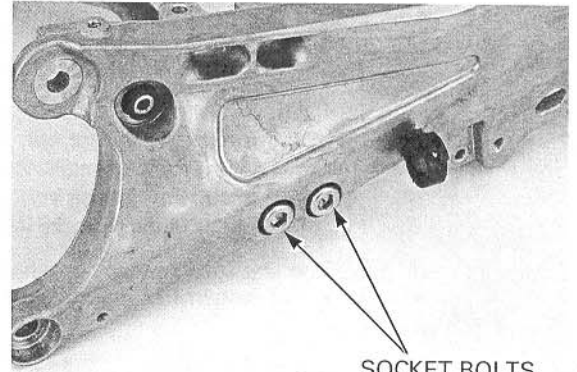

SOCKET BOLTS

Remove the seat rail assembly flange bolts/nuts and separate the seat rails.

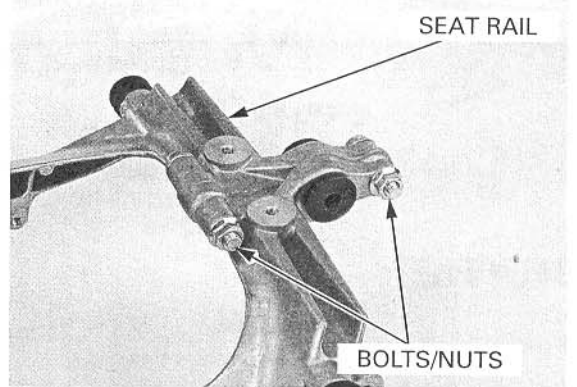

SEAT RAIL

BOLTS/NUTS

Replace the seat rail as an assembly.

Assemble the seat rail by installing the seat rail assembly flange bolt/nut and seat rail brace socket bolts temporarily.

INSTALLATION

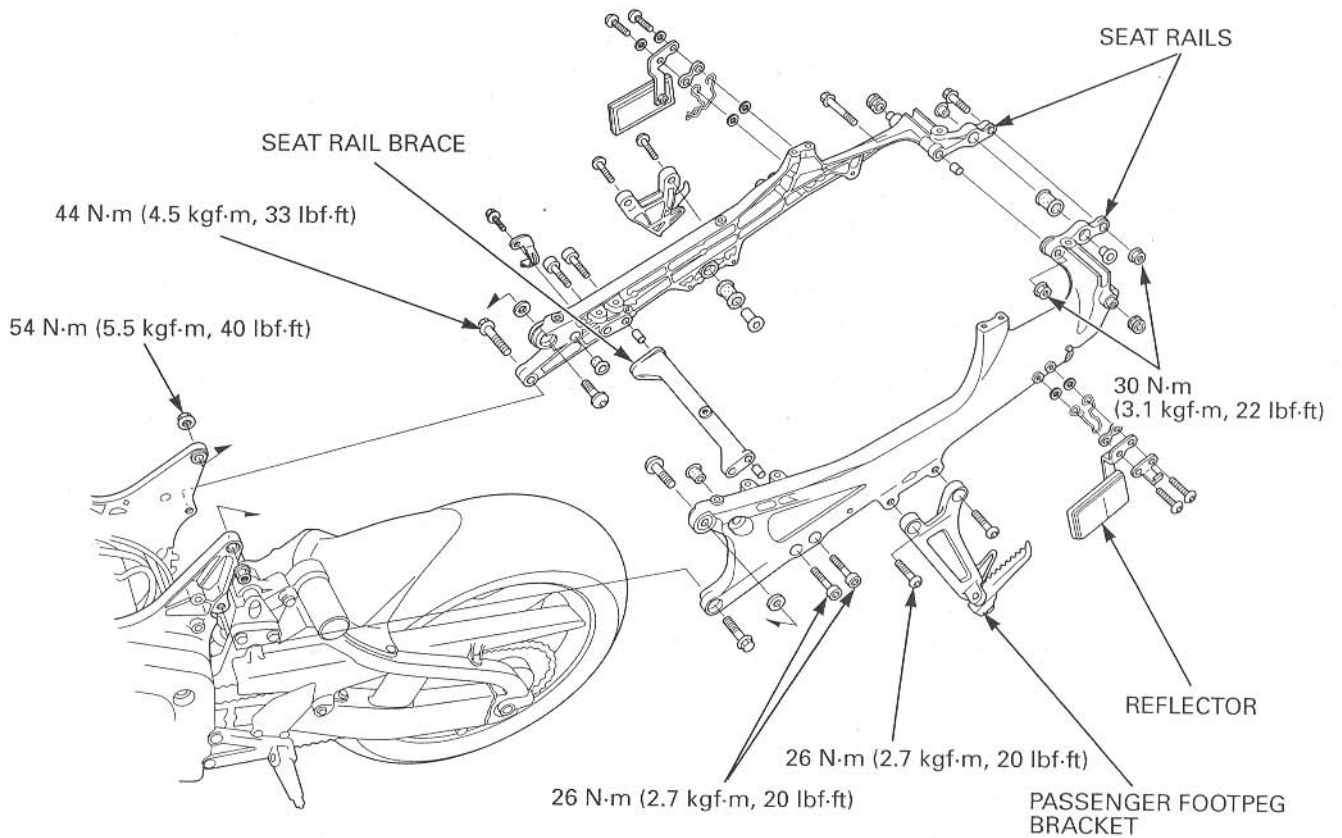

FRAME/BODY PANELS/EXHAUST SYSTEM

Install the seat rail to the frame.

Install the upper mounting bolts/nuts and lower mounting bolts/collars/nuts.

Tighten the bolts and nuts to the specified torque.

TORQUE:

- Upper mounting flange nut:
54 N·m (5.5 kgf·m, 40 lbf·ft)
- Lower mounting flange bolt:
44 N·m (4.5 kgf·m, 36 lbf·ft)

Tighten the four seat rail brace socket bolts and seat rail assembly flange nuts to the specified torque.

TORQUE:

- Seat rail brace socket bolt:
26 N·m (2.7 kgf·m, 20 lbf·ft)
- Seat rail assembly flange nut:
30 N·m (3.1 kgf·m, 22 lbf·ft)

Install the following:

- Battery tray (page 17-7)
- Fuel tank (page 6-61)
- Rear fender (page 3-18)
- Muffler (page 3-22)

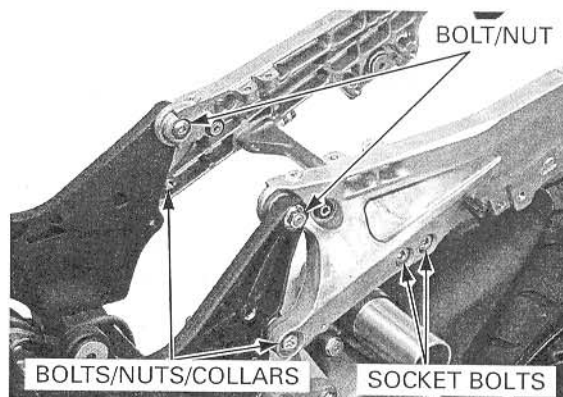

MUFFLER

REMOVAL

Remove the following:

- Lower cowls (page 3-6)
- Rear cowl (page 3-5)

Remove the two bolts, washer and muffler guard.

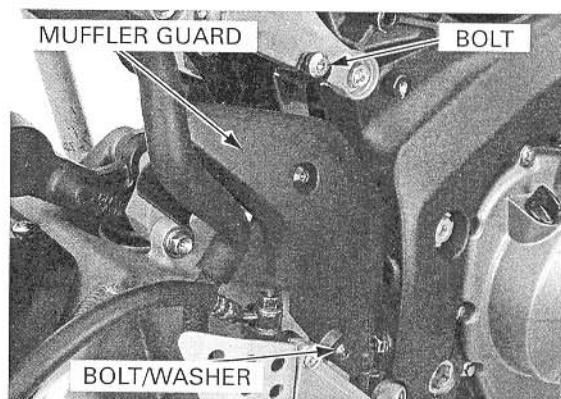

Remove the bolt and rear brake reservoir tank.



FRAME/BODY PANELS/EXHAUST SYSTEM

Remove the socket bolts and right footpeg bracket.

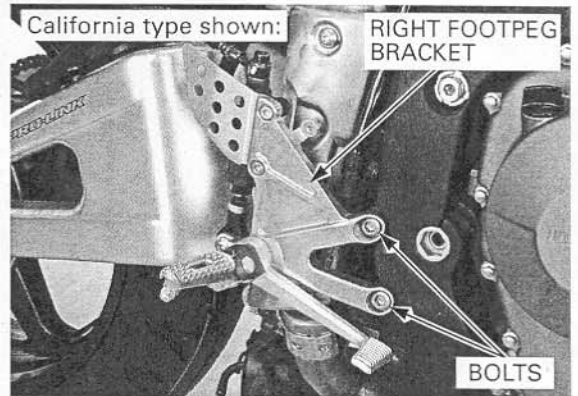

Disconnect the turn signal light and license light connectors.

Remove the four bolts and rear fender B.

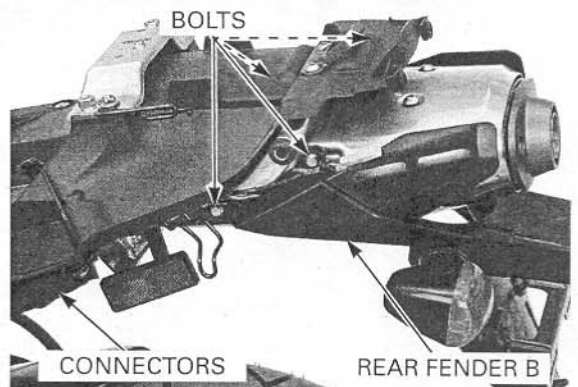

Loosen the muffler band flange bolts.

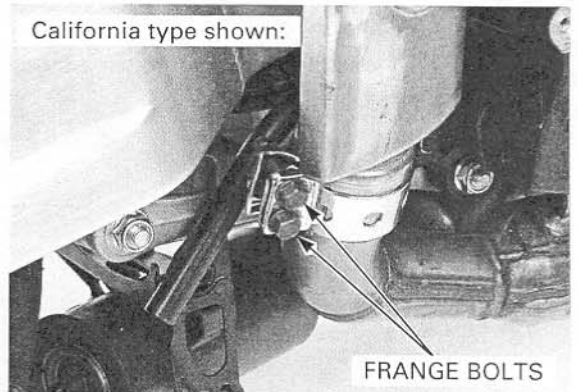

Remove the muffler mounting bolt and washer.

Remove the muffler clamp bolt and nut.

Remove the muffler from the exhaust pipe.

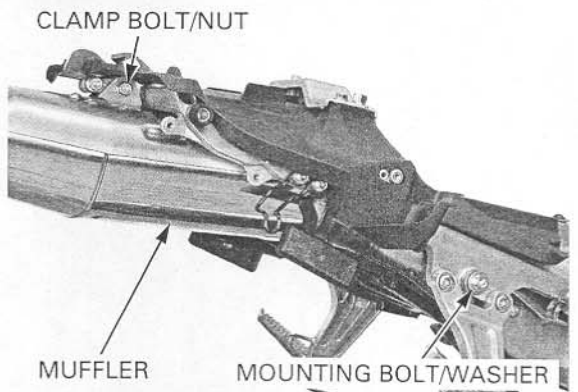

FRAME/BODY PANELS/EXHAUST SYSTEM

INSTALLATION

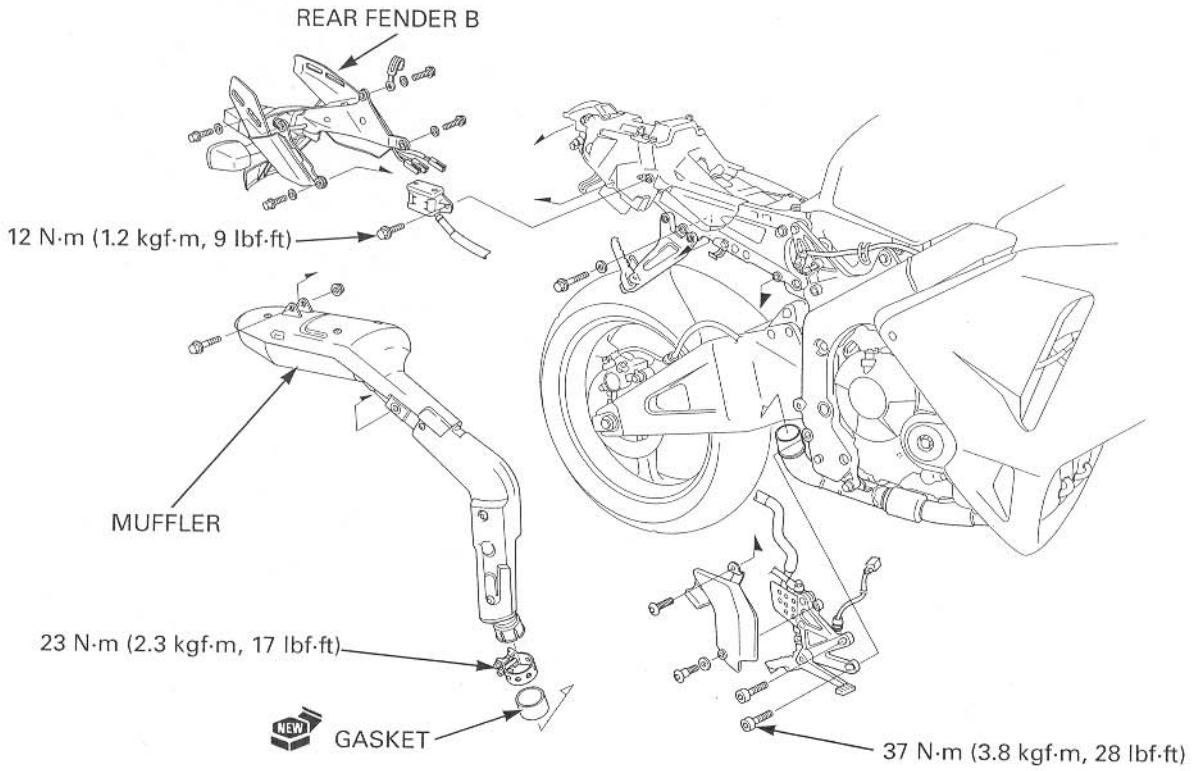

Install a new gasket onto the exhaust pipe.
Install the muffler to the exhaust pipe.

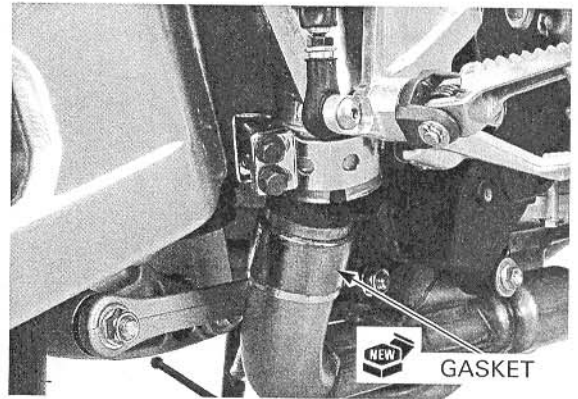

Tighten the muffler mounting bolt/washer and muffler clamp bolt/nut.

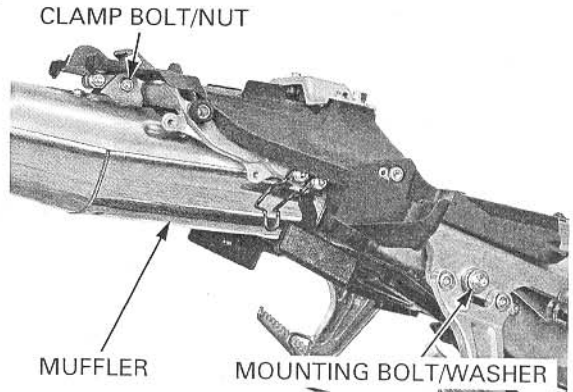

FRAME/BODY PANELS/EXHAUST SYSTEM

Tighten the muffler band flange bolts to the specified torque.

TORQUE: 23 N·m (2.3 kgf·m, 17 lbf·ft)

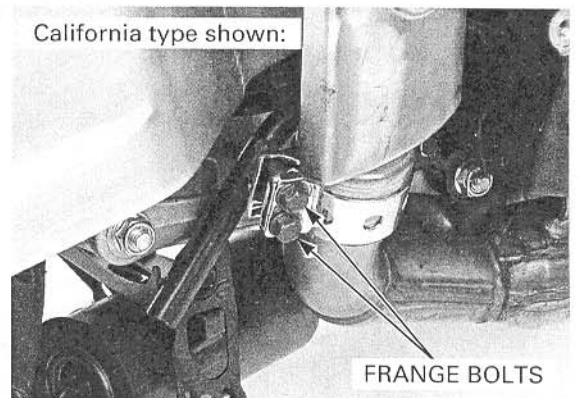

Install the rear fender B and four bolts.

Connect the turn signal light and license light connectors.

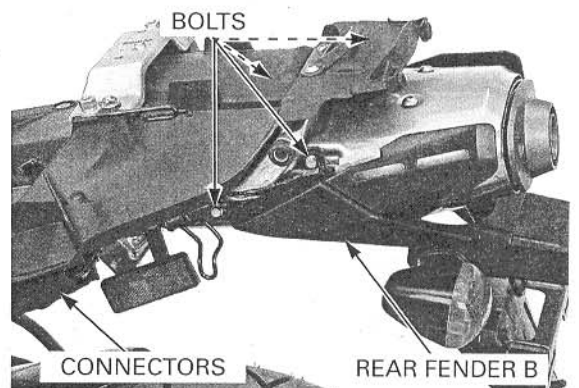

Install the right footpeg bracket and tighten the socket bolts to the specified torque.

TORQUE: 37 N·m (3.8 kgf·m, 28 lbf·ft)

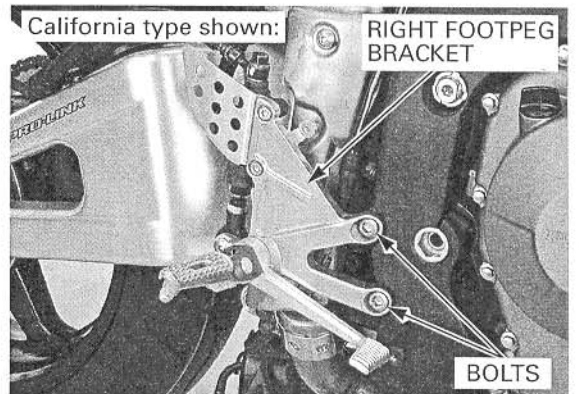

Install the rear brake reservoir tank and tighten the bolt to the specified torque.

TORQUE: 12 N·m (1.2 kgf·m, 9 lbf·ft)



FRAME/BODY PANELS/EXHAUST SYSTEM

Install the muffler guard, washer and two bolts.

Install the following:

- Rear cowl (page 3-5)
- Lower cowls (page 3-6)

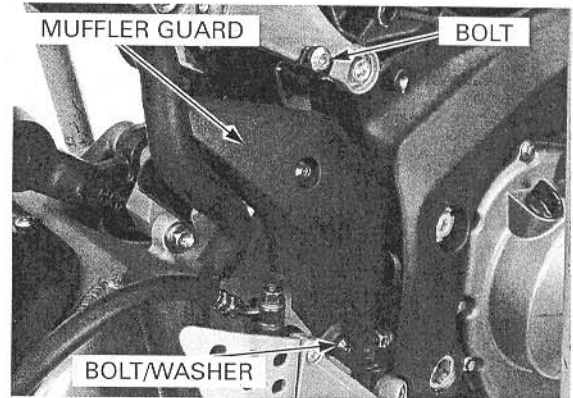

EXHAUST PIPE

REMOVAL

Remove the following:

- Lower cowls (page 3-6)
- Middle cowls (page 3-7)

California type only: Disconnect the O₂ sensor 4P (Natural) connectors.

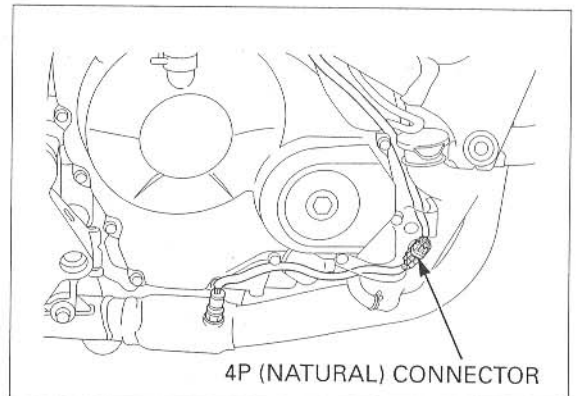
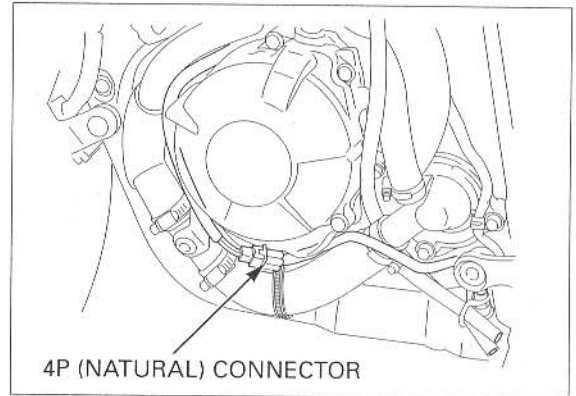

Loosen the muffler band flange bolts.

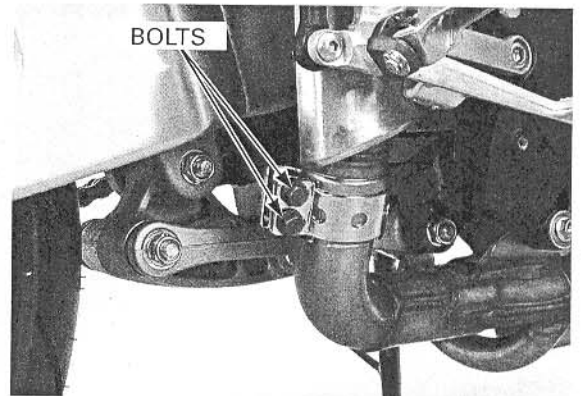

FRAME/BODY PANELS/EXHAUST SYSTEM

Remove the radiator lower mounting bolt/nut, then move the radiator forward.

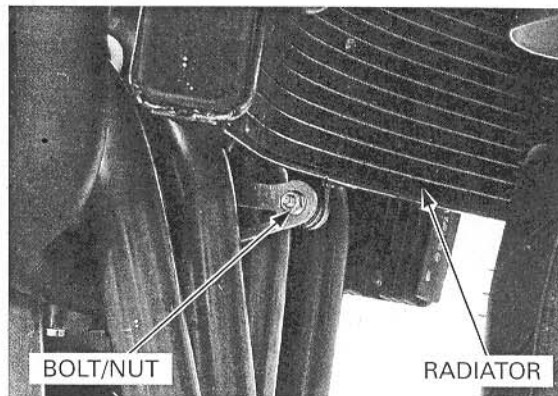

Remove the exhaust pipe joint nuts.

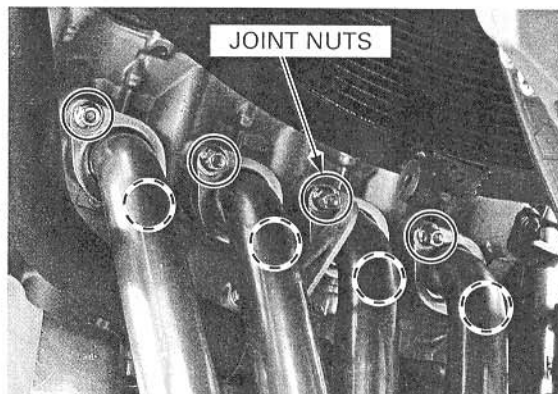

Remove the bolts/nut/washers and exhaust pipe.

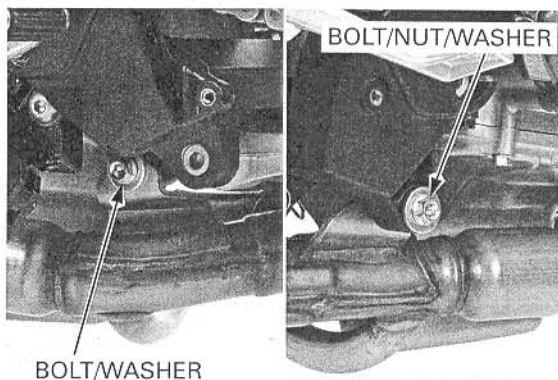

Remove the exhaust pipe gaskets.

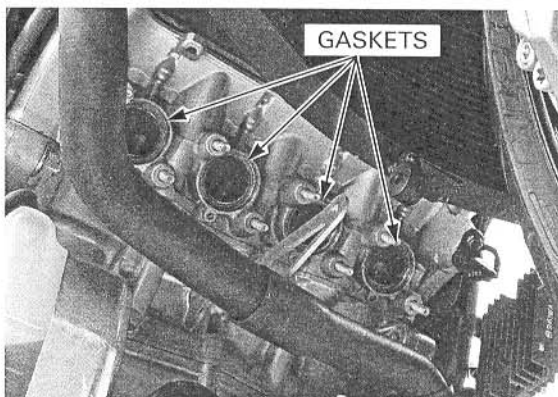

FRAME/BODY PANELS/EXHAUST SYSTEM

INSTALLATION

Except California type:

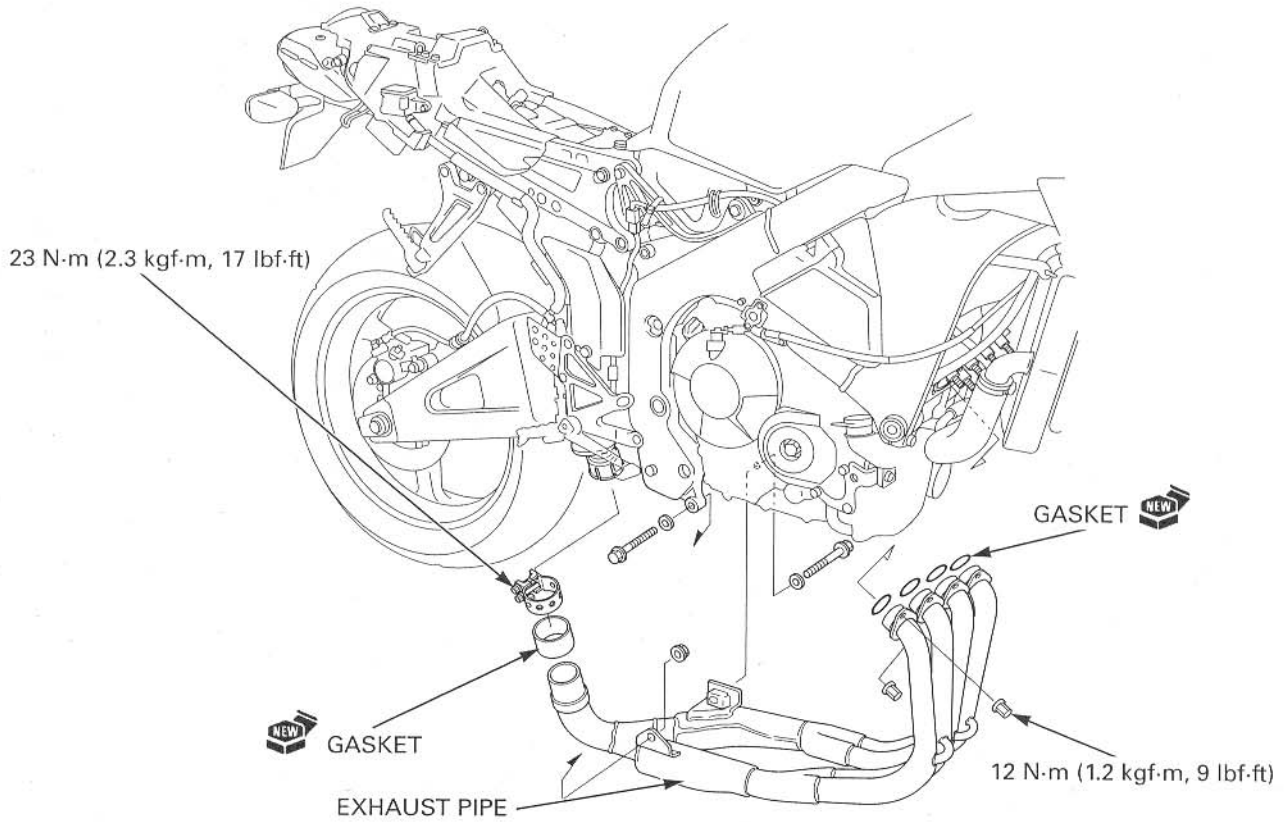

California type:

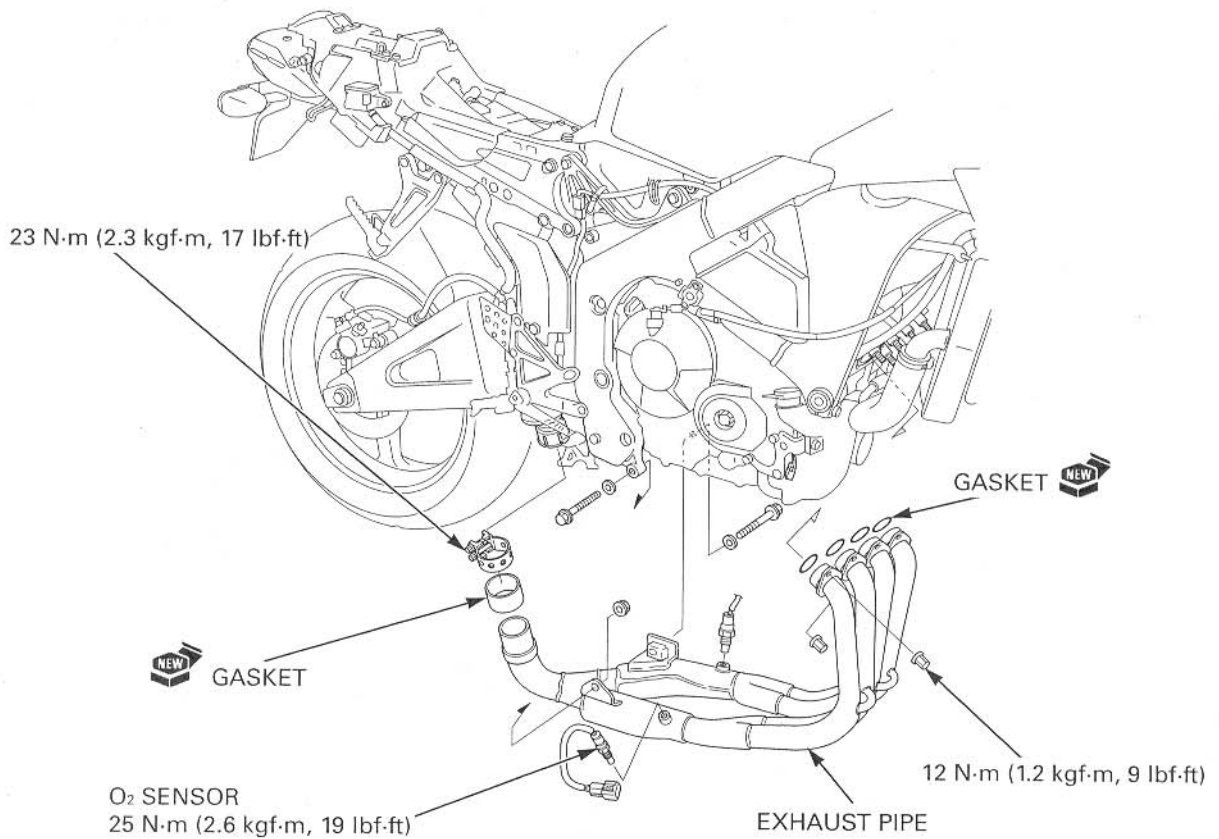

FRAME/BODY PANELS/EXHAUST SYSTEM

Always replace the exhaust pipe gaskets with new ones.

Install a new exhaust pipe gaskets onto the exhaust ports of the cylinder head.

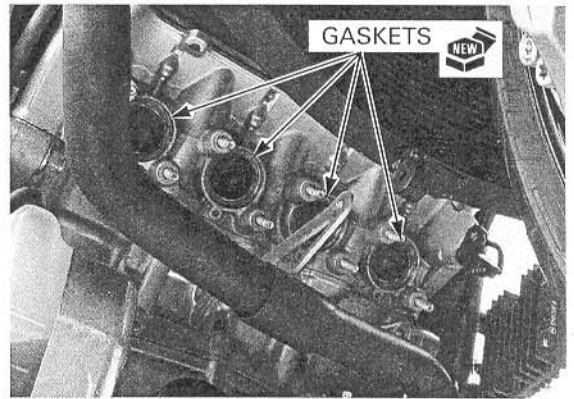

Install a new gasket onto the exhaust pipe and install the exhaust pipe into the muffler.

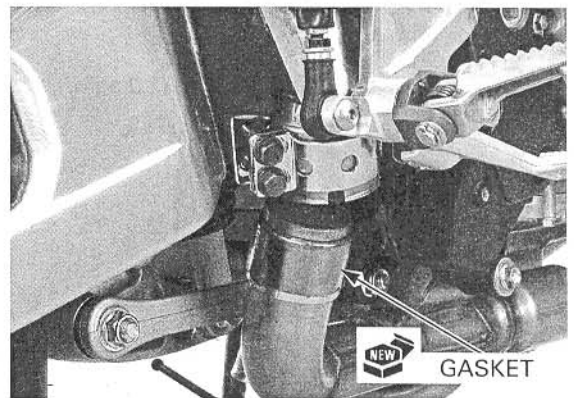

Temporarily install the exhaust pipe joint nuts, and mounting bolts/nut/washers.

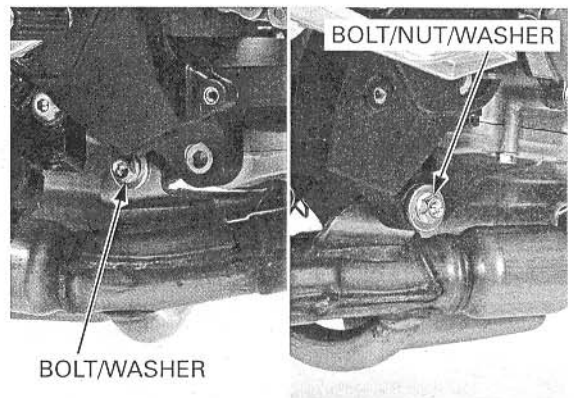

1. Tighten the exhaust pipe joint nuts to the specified torque.

TORQUE: 12 N·m (1.2 kgf·m, 9 lbf·ft)

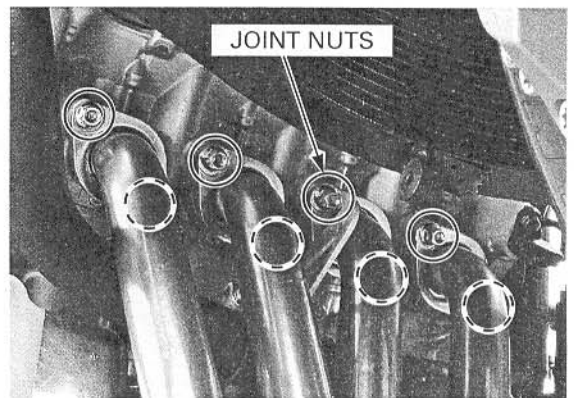

FRAME/BODY PANELS/EXHAUST SYSTEM

2. Tighten the exhaust pipe mounting bolts/nut securely.

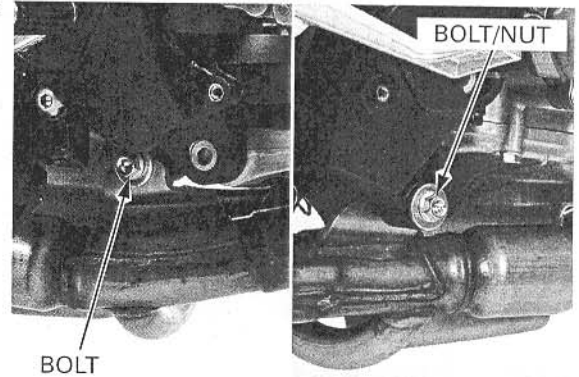

3. Tighten the muffler band flange bolts to the specified torque.

TORQUE: 23 N·m (2.3 kgf·m, 17 lbf·ft)

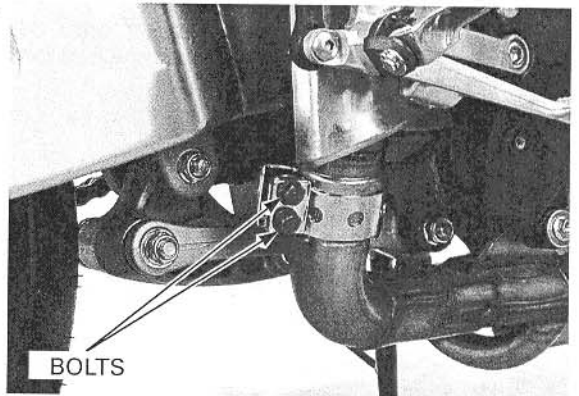

Install the radiator lower mounting bolt/nut and tighten the nut.

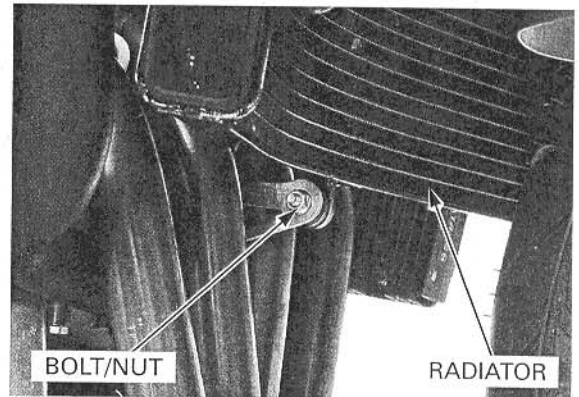

California type only: Route the O₂ sensor wire into the frame. Connect the O₂ sensor 4P (Natural) connectors.

Install the following:

- Upper cowl (page 3-12)
- Middle cowls (page 3-8)
- Lower cowls (page 3-6)

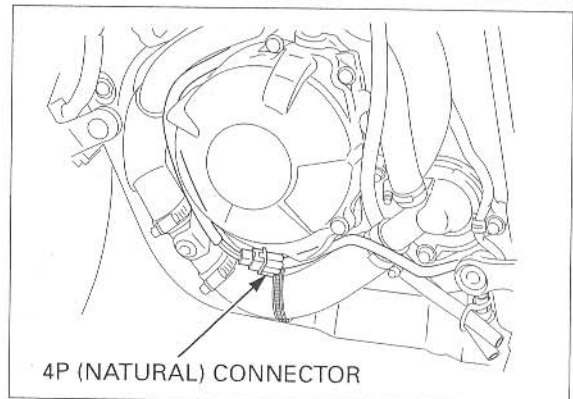

FRAME/BODY PANELS/EXHAUST SYSTEM

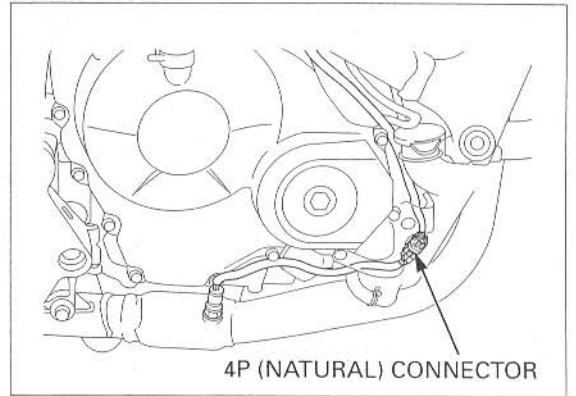

4. MAINTENANCE

SERVICE INFORMATION	4-2	DRIVE CHAIN.....	4-21
MAINTENANCE SCHEDULE	4-4	BRAKE FLUID.....	4-25
FUEL LINE	4-5	BRAKE PAD WEAR.....	4-26
THROTTLE OPERATION.....	4-6	BRAKE SYSTEM	4-26
AIR CLEANER.....	4-6	BRAKE LIGHT SWITCH	4-27
SPARK PLUG	4-7	HEADLIGHT AIM	4-28
VALVE CLEARANCE.....	4-11	CLUTCH SYSTEM.....	4-28
ENGINE OIL/OIL FILTER	4-15	SIDE STAND	4-29
ENGINE IDLE SPEED	4-18	SUSPENSION	4-29
RADIATOR COOLANT	4-18	NUTS, BOLTS, FASTENERS.....	4-33
COOLING SYSTEM.....	4-19	WHEELS/TIRES	4-33
SECONDARY AIR SUPPLY SYSTEM.....	4-19	STEERING HEAD BEARINGS	4-34
EVAPORATIVE EMISSION CONTROL SYSTEM (CALIFORNIA TYPE ONLY)	4-20		

MAINTENANCE

SERVICE INFORMATION

GENERAL

- Place the motorcycle on a level ground before starting any work.
- The exhaust contains poisonous carbon monoxide gas that may cause loss of consciousness and may lead to death. Run the engine in an open area or with an exhaust evacuation system in and enclosed area.

SPECIFICATIONS

ITEM		SPECIFICATIONS	
Throttle grip free play		2 – 4 mm (1/16 – 1/8 in)	
Spark plug		IMR9C-9HE (NGK)	
Spark plug gap		0.80 – 0.90 mm (0.031 – 0.035 in)	
Valve clearance	IN	0.20 ± 0.03 mm (0.008 ± 0.001 in)	
	EX	0.28 ± 0.03 mm (0.011 ± 0.001 in)	
Engine oil capacity	After draining	2.6 liter (2.7 US qt, 2.3 Imp qt)	
	After oil filter change	2.9 liter (3.1 US qt, 2.6 Imp qt)	
Recommended engine oil		Pro Honda GN4 or HP4 (without molybdenum additives) 4-stroke oil (U.S.A. & Canada) or Honda 4-stroke oil (Canada only), or an equivalent motorcycle oil API service classification: SG or higher except oils labeled as energy consening on the circular API service label JASO T 903 standard: MA Viscosity: SAE 10W-40	
Engine idle speed		1,300 ± 100 rpm	
Drive chain	Size/link	DID	DID525HV-120ZB
		RK	RK525ROZ1-120LJ-FZ
Slack		25 – 35 mm (1 – 1-3/8 in)	
Recommended brake fluid		Honda DOT 4 brake fluid	
Clutch lever free play		10 – 20 mm (3/8 – 13/16 in)	
Tire size	Front	120/70 ZR 17 M/C (58W)	
	Rear	180/55 ZR 17 M/C (73W)	
Tire brand	Bridgestone	Front	BT012F RAGIAL G
		Rear	BT012R RAGIAL L
	Dunlop	Front	D208FK
		Rear	D208K
	Michelin	Front	Pilot SPORT E
		Rear	Pilot SPORT E
Tire air pressure	Driver only	Front	250 kPa (2.50 kgf/cm ² , 36 psi)
		Rear	290 kPa (2.90 kgf/cm ² , 42 psi)
	Driver and passenger	Front	250 kPa (2.50 kgf/cm ² , 36 psi)
		Rear	290 kPa (2.90 kgf/cm ² , 42 psi)
Minimum tire tread depth	Front	1.5 mm (0.06 in)	
	Rear	2.0 mm (0.08 in)	

TORQUE VALUES

Spark plug	16 N·m (1.6 kgf·m, 12 lbf·ft)	
Timing hole cap	18 N·m (1.8 kgf·m, 13 lbf·ft)	Apply grease to the threads
Cylinder head cover bolt	9.8 N·m (1.0 kgf·m, 7 lbf·ft)	
Engine oil drain bolt	29 N·m (3.0 kgf·m, 22 lbf·ft)	
Engine oil filter cartridge	26 N·m (2.7 kgf·m, 20 lbf·ft)	Apply clean engine oil to the O-ring
Rear axle nut	113 N·m (11.5 kgf·m, 83 lbf·ft)	U-nut
Drive sprocket special bolt	54 N·m (5.5 kgf·m, 40 lbf·ft)	
Final driven sprocket nut	64 N·m (6.5 kgf·m, 47 lbf·ft)	U-nut
Rear master cylinder push rod joint nut	18 N·m (1.8 kgf·m, 13 lbf·ft)	

TOOLS

Oil filter wrench
07HAA-PJ70101

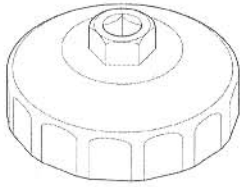

or 07HAA-PJ70100 (U.S.A. only)

Drive chain tool set
07HMH-MR10103

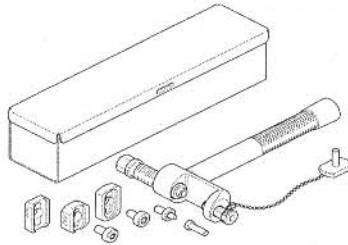

or 07HMH-MR1010C (U.S.A. only)

MAINTENANCE

MAINTENANCE SCHEDULE

Perform the Pre-ride inspection in the Owner's Manual at each scheduled maintenance period.

I: Inspect and Clean, Adjust, Lubricate or Replace if necessary. C: Clean. R: Replace. A: Adjust. L: Lubricate.

The following items require some mechanical knowledge. Certain items (particularly those marked * and **) may require more technical information and tools. Consult their authorized Honda dealer.

ITEMS	FREQUENCY	WHICHEVER COMES FIRST ↓	ODOMETER READING (NOTE 1)								REFER TO PAGE
			X1,000 mi	0.6	4	8	12	16	20	24	
			X1,000 km	1.0	6.4	12.8	19.2	25.6	32.0	38.4	
* FUEL LINE										4-5	
* THROTTLE OPERATION										4-6	
* AIR CLEANER		NOTE2								4-6	
SPARK PLUG							EVERY 25,750 km (16,000 mi) I, EVERY 51,500 km (32,000 mi) R			4-7	
* VALVE CLEARANCE										4-11	
ENGINE OIL			R		R		R		R	4-15	
ENGINE OIL FILTER			R		R		R		R	4-15	
* ENGINE IDLE SPEED										4-18	
RADIATOR COOLANT		NOTE3							R	4-18	
* COOLING SYSTEM										4-19	
* SECONDARY AIR SUPPLY SYSTEM										4-19	
* EVAPORATIVE EMISSION CONTROL SYSTEM		NOTE 4								4-20	
DRIVE CHAIN							EVERY 500 mi (800 km) I, L			4-21	
BRAKE FLUID		NOTE3				R			R	4-25	
BRAKE PAD WEAR										4-26	
BRAKE SYSTEM										4-26	
* BRAKE LIGHT SWITCH										4-27	
* HEADLIGHT AIM										4-28	
CLUTCH SYSTEM										4-28	
SIDE STAND										4-29	
* SUSPENSION										4-29	
* NUTS, BOLTS, FASTENERS										4-33	
** WHEELS/TIRES										4-33	
** STEERING HEAD BEARINGS										4-34	

* Should be serviced by an authorized Honda dealer, unless the owner has proper tools and service data and is mechanically qualified

** In the interest of safety, we recommended these items be serviced only by an authorized Honda dealer

NOTES:

- At higher odometer reading, repeat at the frequency interval established here.
- Service more frequency if the motorcycle is ridden in unusually wet or dusty areas.
- Replace every 2 years, or at indicated odometer interval, whichever comes first. Replacement requires mechanical skill.
- California type only.

FUEL LINE

Remove the fuel tank cover (page 3-15).
Remove the fuel tank mounting bolts.

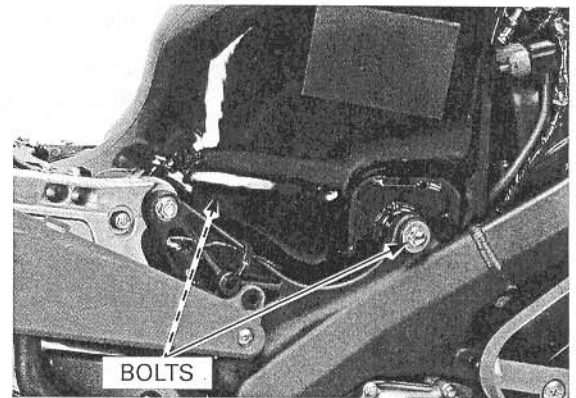

Lift the front end of fuel tank and release the fuel hose from the clamp.

Support the fuel tank using a suitable support as shown.

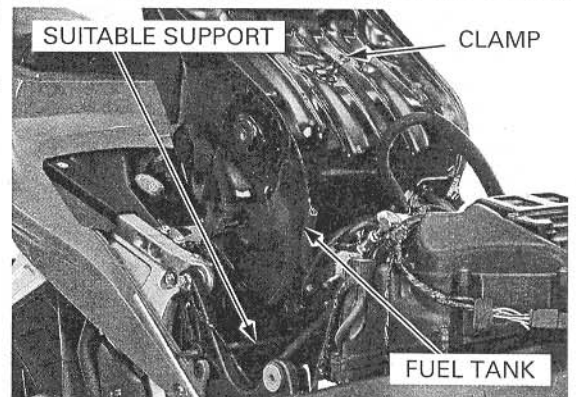

Check the fuel lines for deterioration, damage or leakage. Replace the fuel line if necessary.
Check the fuel pipes and fuel line joint for damage or leakage. Replace them if necessary.
Check the fuel pump mounting area for leakage. Replace the fuel pump packing if necessary.
Check the upper/lower injectors for damage or leakage. Replace them if necessary.

Route the wires and harness properly (page 1-22). Be careful not to damage the harness and hose.

Remove a suitable support, then lower the fuel tank.

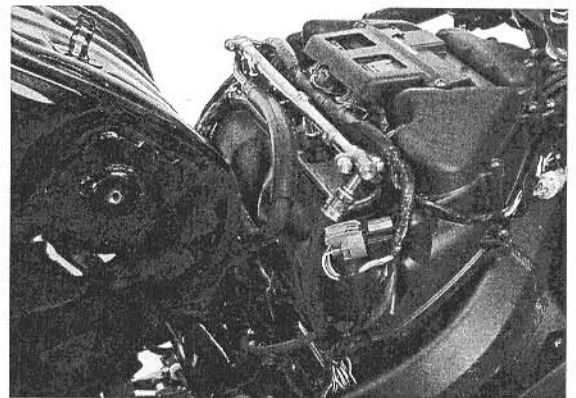

Install and tighten the fuel tank mounting bolts securely.

Install the fuel tank cover (page 3-15).

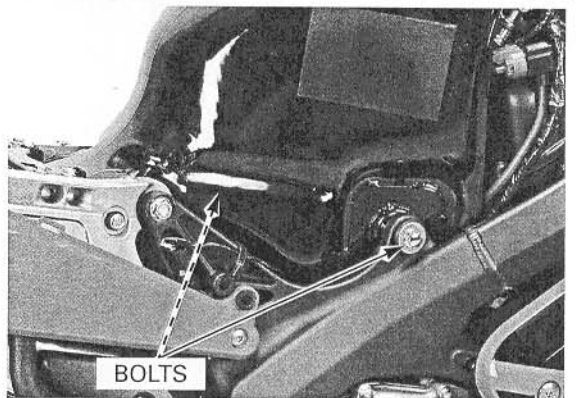

MAINTENANCE

THROTTLE OPERATION

Check for smooth throttle grip full opening and automatic full closing in all steering positions. Check the throttle cables and replace them if they are deteriorated, kinked or damaged. Lubricate the throttle cables, if throttle operation is not smooth.

Measure the free play at the throttle grip flange.

FREE PLAY: 2 – 4 mm (1/16 – 1/8 in)

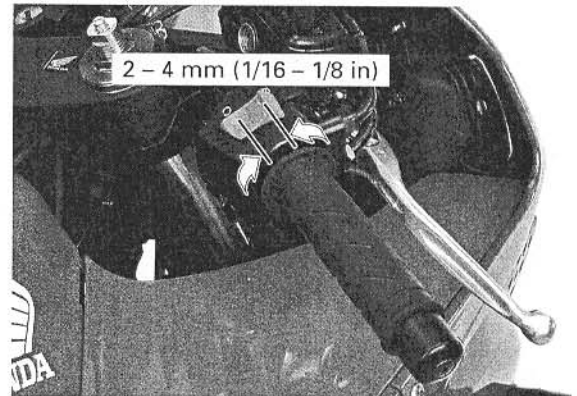

Throttle grip free play can be adjusted at either end of the throttle cable.

Minor adjustment is made with the upper adjuster. Adjust the free play by loosening the lock nut and turning the adjuster.

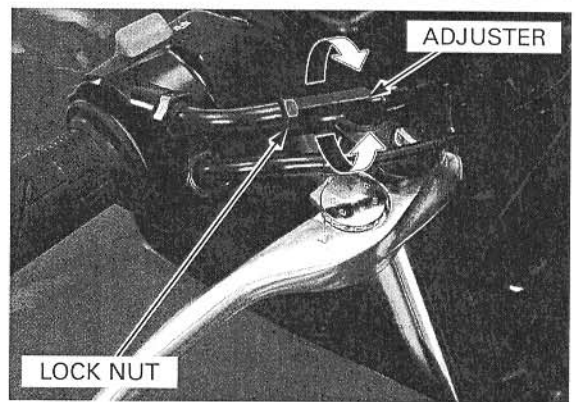

Major adjustment is made with the lower adjuster.

Remove the air cleaner housing (page 6-64).

Adjust the free play by loosening the lock nut and turning the adjuster.

After adjustment, tighten the lock nut securely.

Recheck the throttle operation.

Replace any damaged parts, if necessary.

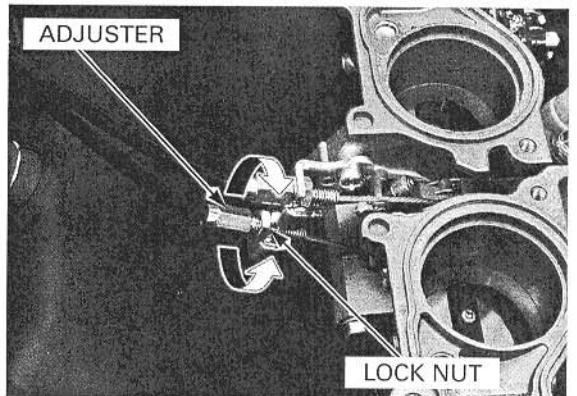

AIR CLEANER

Remove the following:

- Fuel tank cover (page 3-15)
- ECM (page 6-94)

Remove the air cleaner housing cover screws.

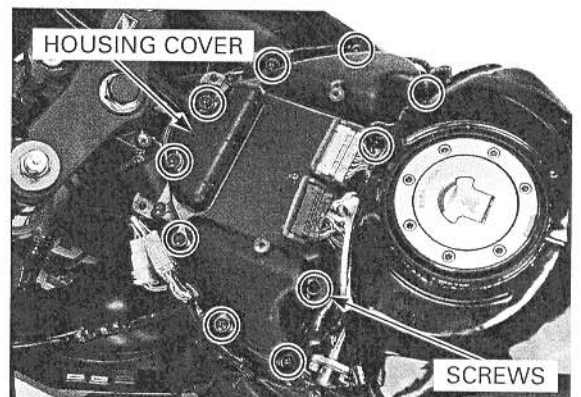

Pull up the air cleaner housing cover and disconnect the IAT sensor connector.

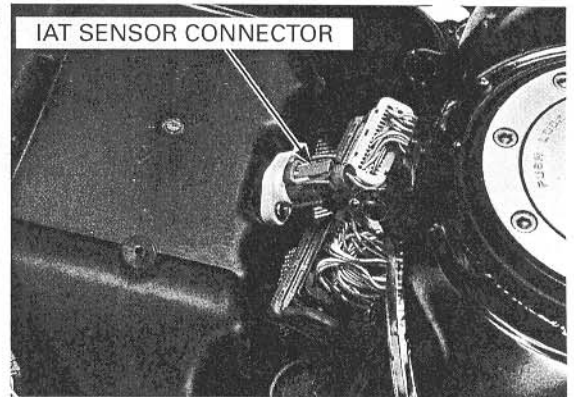

Remove the three screws. Remove and discard the air cleaner element in accordance with the maintenance schedule (page 4-4). Also replace the air cleaner element any time it is excessively dirty or damage.

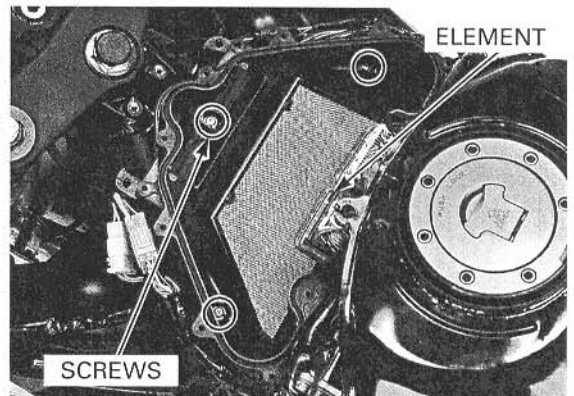

Install the removed parts in the reverse order of removal.

SPARK PLUG

REMOVAL

Be careful not to damage the radiator fins.

Remove the following:

- Lower cowls (page 3-6)
- Middle cowls (page 3-7)

Remove the two trim clips and resonator chambers from the radiator.

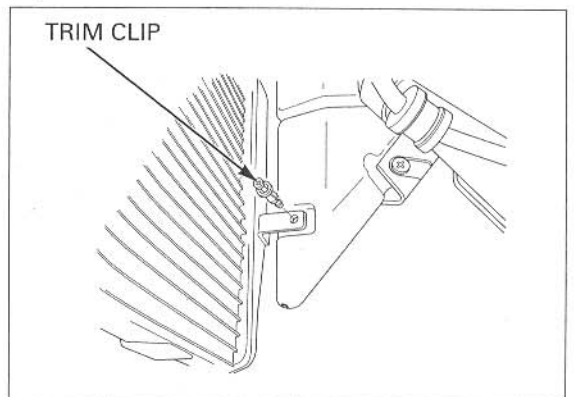

Remove the radiator lower mounting bolt, nut and washer.

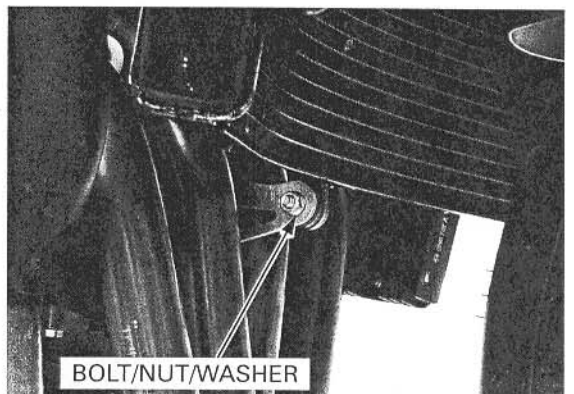

MAINTENANCE

Remove the wire band.

Remove the radiator upper mounting bolt and washer and horn mounting stay.

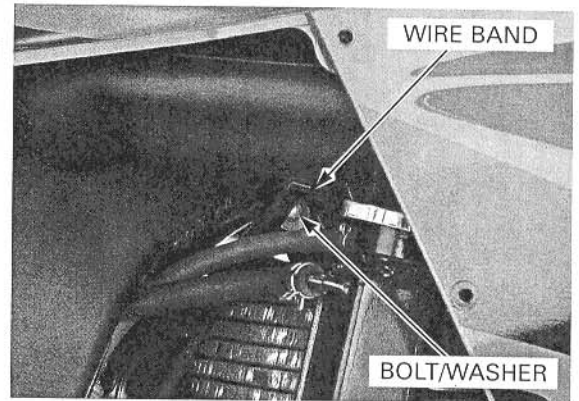

Release the radiator grommet from the frame boss by moving the radiator to the left side, then move the radiator downward.

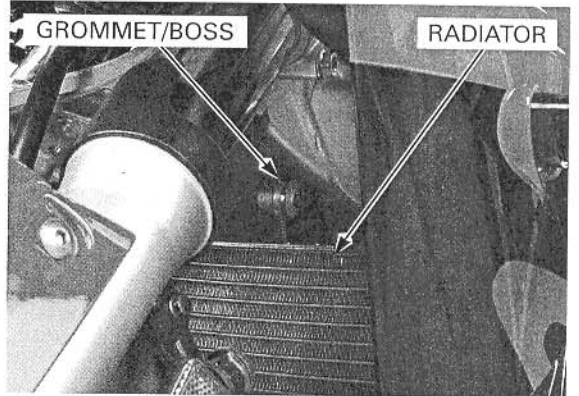

Disconnect the direct ignition coil connectors.

Clean around the spark plug bases with compressed air before removing, and be sure that no debris is allowed to enter the combustion chamber.

Remove the direct ignition coils from the spark plugs.

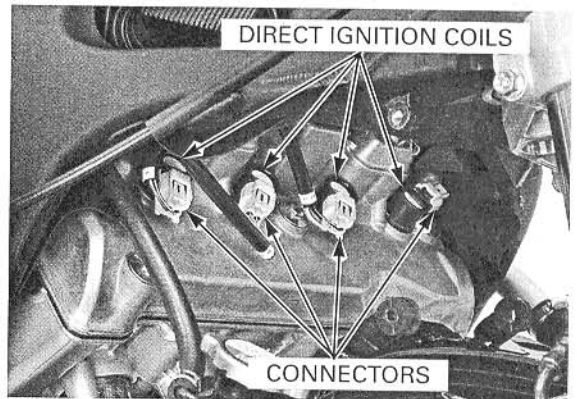

Remove the spark plug using a equipped spark plug wrench or an equivalent.

Inspect or replace as described in the maintenance schedule (page 4-4).

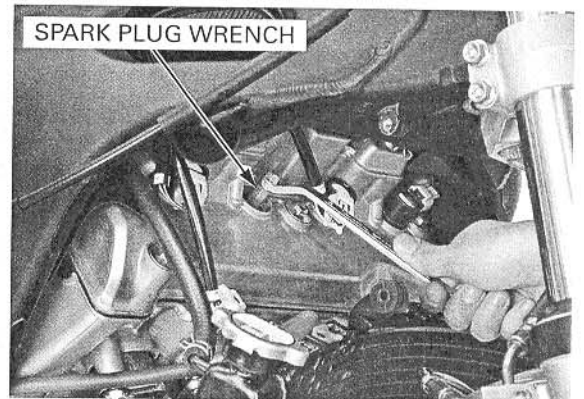

INSPECTION

Check the following and replace if necessary (recommended spark plug: page 4-2)

- Insulator for damage
- Electrodes for wear
- Burning condition, coloration

This motorcycle's spark plug equipped with iridium center electrode. Replace the spark plug if the electrodes are contaminated.

If the electrodes are contaminated with accumulated objects or dirt, replace the spark plug.

Replace the plug if the center electrode is rounded as shown in the illustration.

Always use specified spark plugs on this motorcycle.

SPECIFIED SPARK PLUG: IMR9C-9HE (NGK)

To prevent damaging the iridium center electrode, use a wire type feeler gauge to check the spark plug gap.

Check the gap between the center and side electrodes with a wire type feeler gauge.

Make sure that the ϕ 1.0 mm (0.04 in) plug gauge does not insert between the gap.

Do not adjust the spark plug gap. If the gap is out of specification, replace with a new one.

If the gauge can be inserted into the gap, replace the plug with a new one.

Reinstall the spark plug in the cylinder head and hand tighten, then torque to specification.

TORQUE: 16 N·m (1.6 kgf·m, 12 lbf·ft)

If using the new plug, install as follows:

Do not over tighten the plug.

Install and hand tighten the new spark plug, then tighten it about 1/2 turn after the sealing washer contacts the seat of the plug hole.

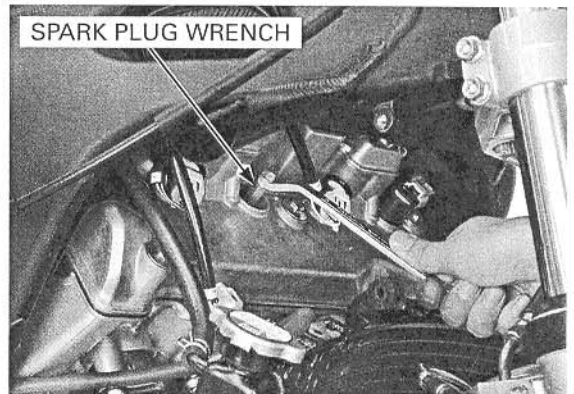
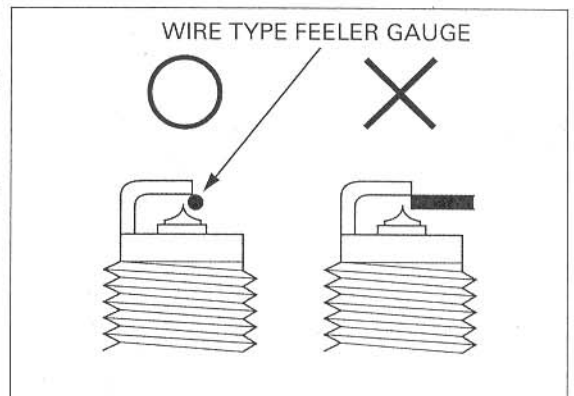
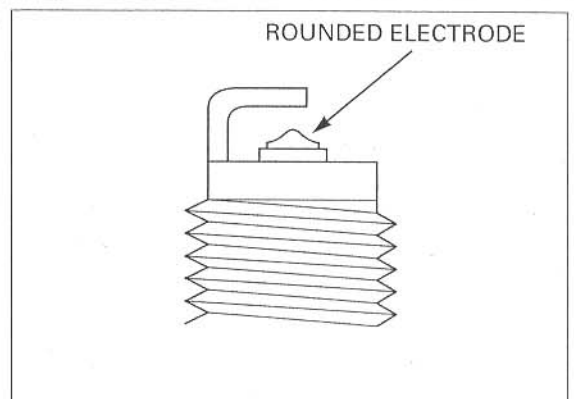
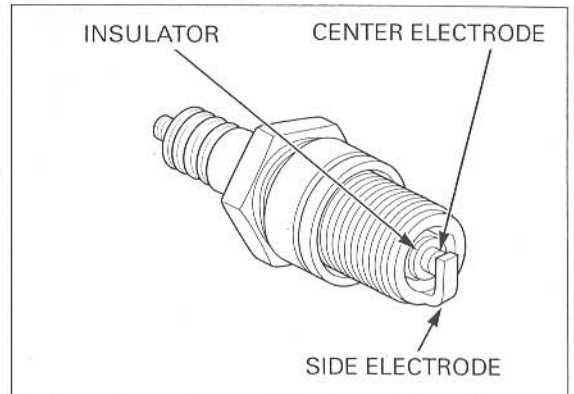

MAINTENANCE

Install the direct ignition coils.
Connect the direct ignition coil connectors.

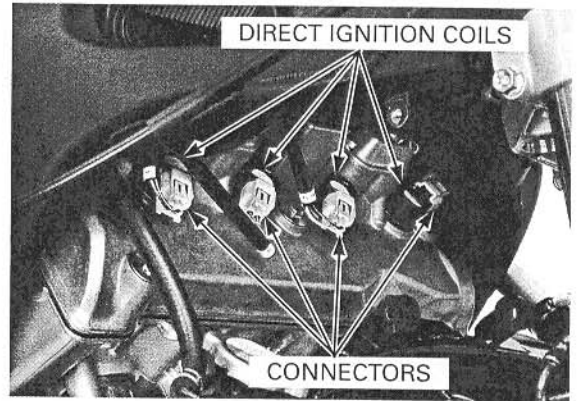

Install the radiator by aligning the grommet and frame boss.

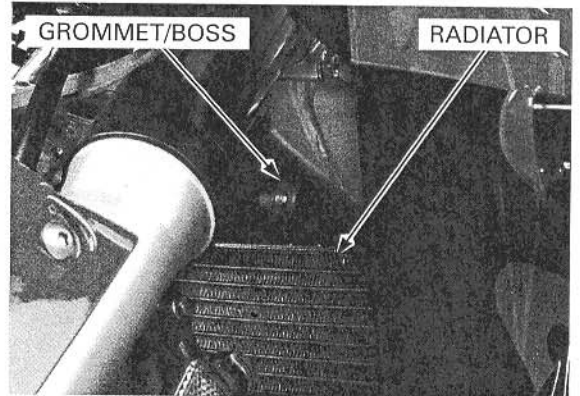

Install the horn mounting stay, washer and radiator upper mounting bolt.
Install the wire band.

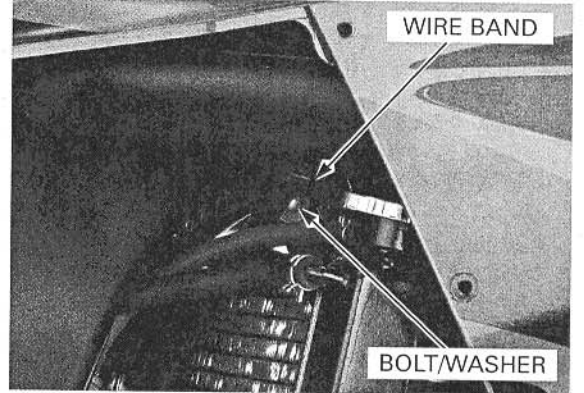

Install the radiator lower mounting bolt, washer and nut.
Tighten the nut securely.



Install the trim clips and resonator chambers onto the radiator.

Install the following:

- Middle cowls (page 3-8)
- Lower cowls (page 3-6)

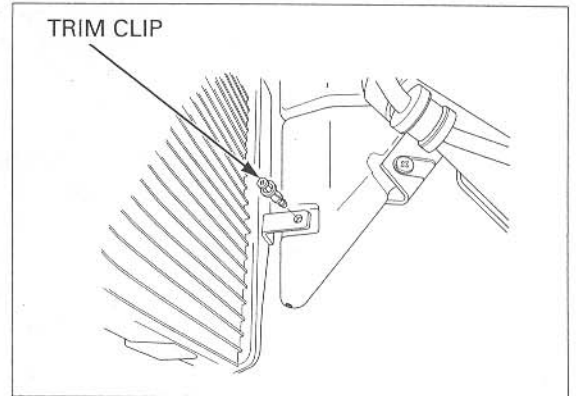

VALVE CLEARANCE

Inspect and adjust the valve clearance while the engine is cold (below 35°C/95°F).

INSPECTION

Remove the cylinder head cover (page 9-6).

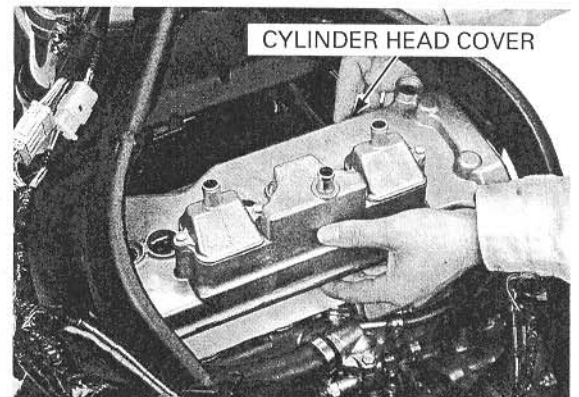

Remove the timing hole cap and O-ring.

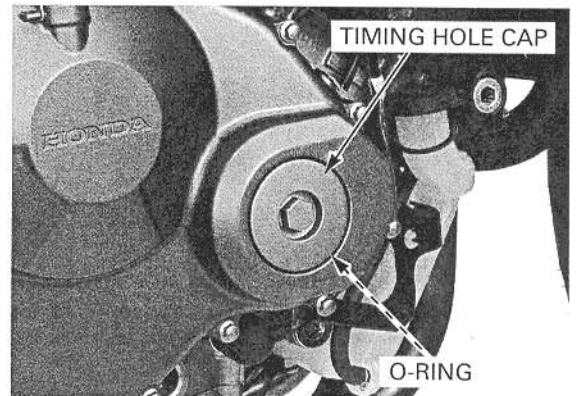

Turn the crankshaft clockwise, align the "T" mark on the ignition pulse generator rotor with the index mark on the right crankcase cover.

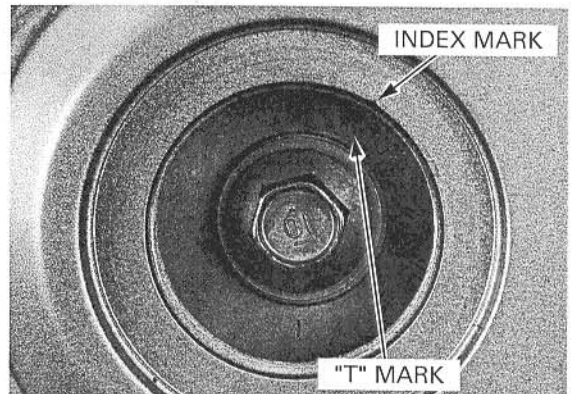

MAINTENANCE

The timing marks ("IN" and "EX") on the cam sprockets must be flush with the cylinder head surface and facing outward as shown.

If the timing marks on the cam sprockets are facing inward, turn the crankshaft clockwise one full turn (360°) and realign the timing marks with the cylinder head surface so they are facing outward.

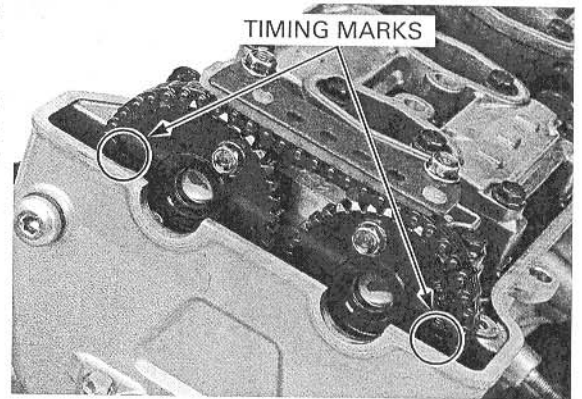

Insert the feeler gauge between the valve lifter and cam lobe.

Record the clearance for each valve for reference in shim selection if adjustment is required.

Check the valve clearance for the No.1 and No.3 cylinder intake valves using a feeler gauge.

VALVE CLEARANCE:

IN: 0.20 ± 0.03 mm (0.008 ± 0.001 in)

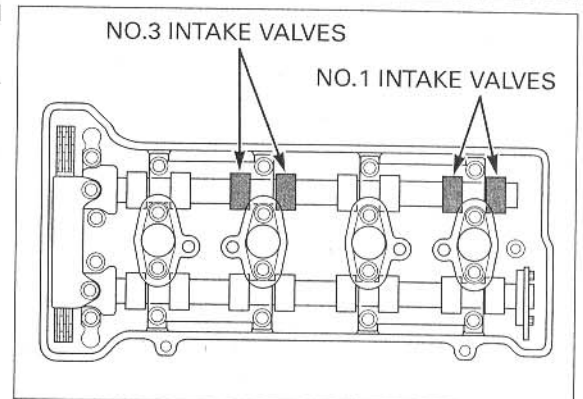

Turn the crankshaft clockwise 1/2 turn (180°), align the index line on the ignition pulse generator rotor so that it is facing up as shown.

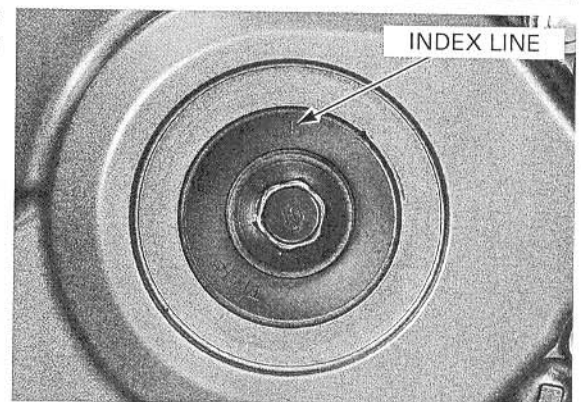

Record the clearance for each valve for reference in shim selection if adjustment is required.

Check the valve clearance for the No.2 and No.4 cylinder exhaust valves using a feeler gauge.

VALVE CLEARANCE:

EX: 0.28 ± 0.03 mm (0.011 ± 0.001 in)

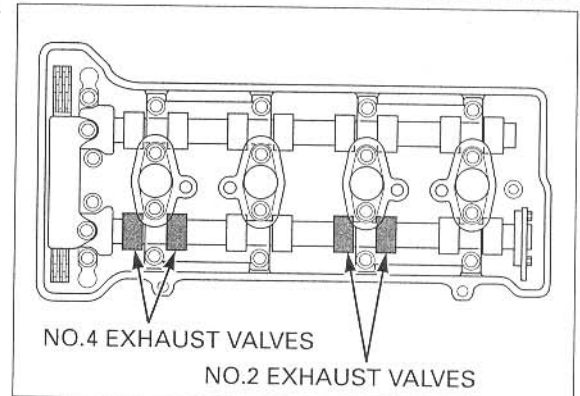

Turn the crankshaft clockwise 1/2 turn (180°), align the "T" mark on the ignition pulse generator rotor with the index mark on the right crankcase cover.

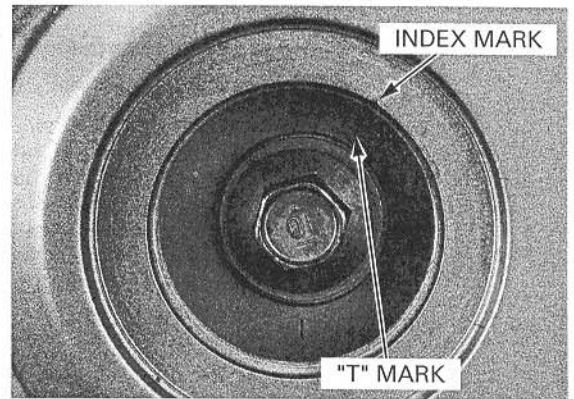

Record the clearance for each valve for reference in shim selection if adjustment is required.

Check the valve clearance for the No.2 and No.4 cylinder intake valves using feeler gauge.

VALVE CLEARANCE:
IN: 0.20 ± 0.03 mm (0.008 ± 0.001 in)

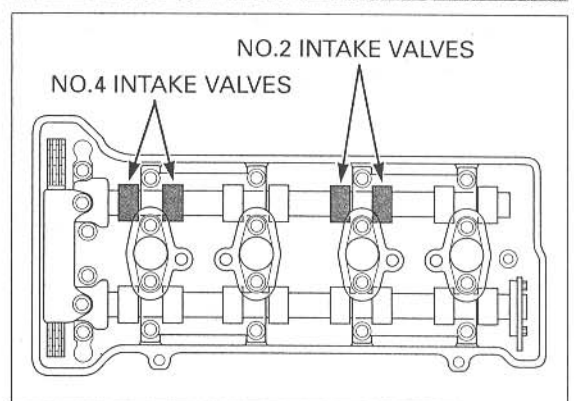

Turn the crankshaft clockwise 1/2 turn (180°), align the index line on the ignition pulse generator rotor so that it is facing up as shown.

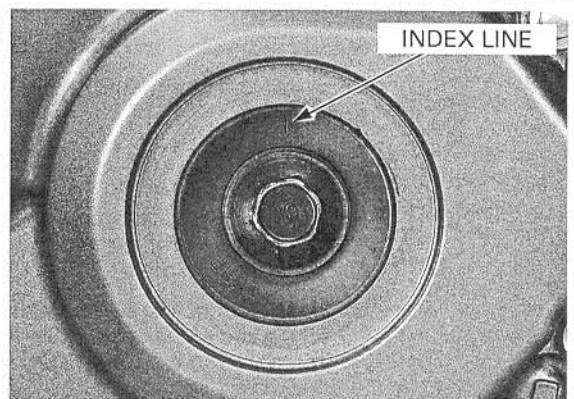

Record the clearance for each valve for reference in shim selection if adjustment is required.

Check the valve clearance for the No.1 and No.3 cylinder exhaust valves using a feeler gauge.

VALVE CLEARANCE:
EX: 0.28 ± 0.03 mm (0.011 ± 0.001 in)

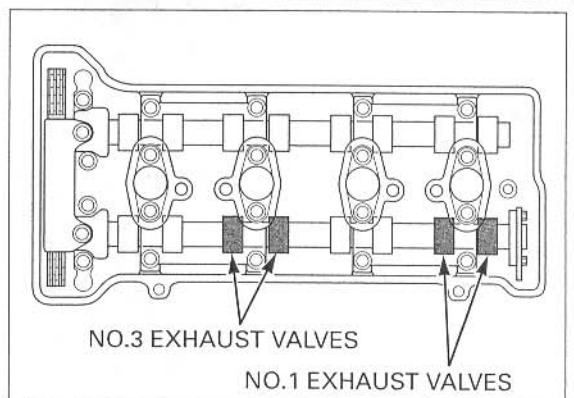

MAINTENANCE

ADJUSTMENT

It is not necessary to remove the cam sprocket from the camshaft except when replacing the camshaft and/or camsprocket.

Remove the camshafts (page 9-8).

Remove the valve lifters and shims.

- Shim may stick to the inside of the valve lifter. Do not allow the shims to fall into the crankcase.
- Mark all valve lifters and shims to ensure correct reassembly in their original locations.
- The valve lifter can be easily removed with a valve lapping tool or magnet.
- The shims can be easily removed with a tweezers or magnet.

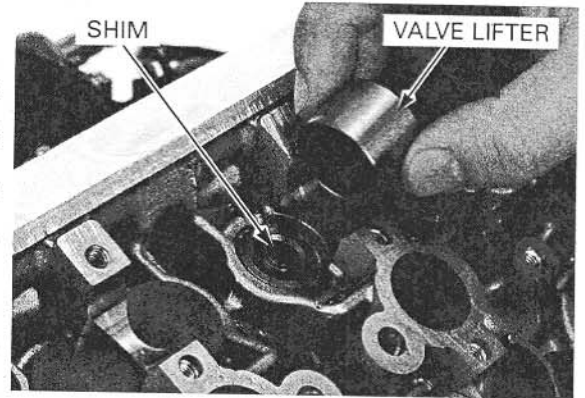

Clean the valve shim contact area in the valve lifter with compressed air.

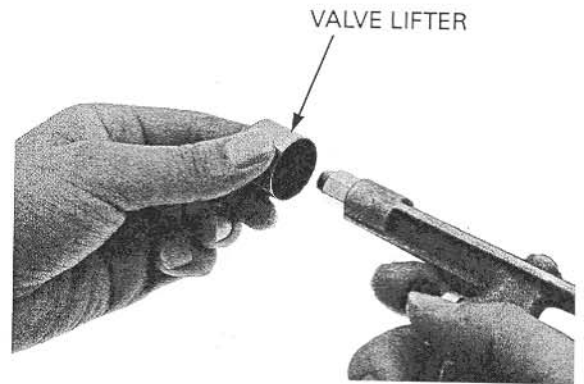

Sixty-nine different thickness shims are available from the thinnest 1.200 mm thickness shim to the thickest 2.900 mm thickness shim in intervals of 0.025 mm.

Measure the shim thickness and record it.

Calculate the new shim thickness using the equation below.

$$A = (B - C) + D$$

A: New shim thickness

B: Recorded valve clearance

C: Specified valve clearance

D: Old shim thickness

- Make sure of the correct shim thickness by measuring the shim by micrometer.
- Reface the valve seat if carbon deposit result in a calculated dimension of over 2.900 mm.

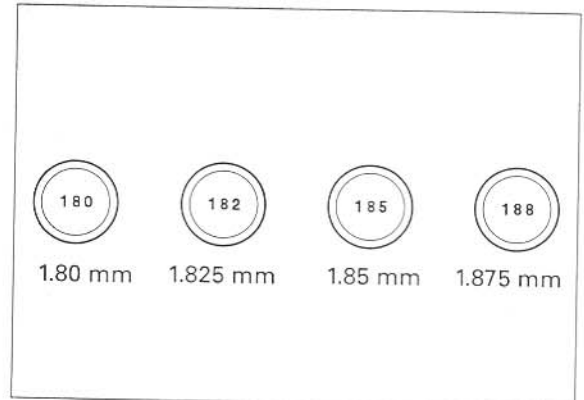
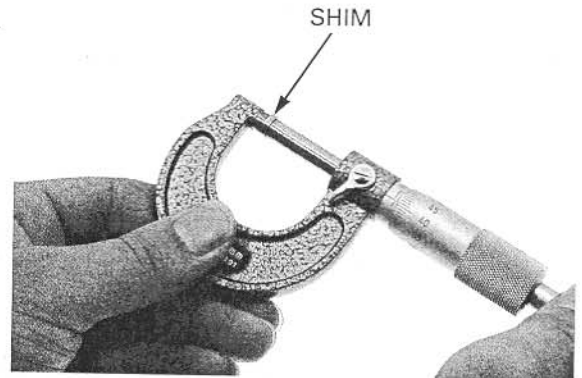

Install the shims and valve lifters in their original locations

Install the newly selected shim on the valve spring retainer.
Apply molybdenum disulfide oil to the valve lifters. Install the valve lifters into the valve lifter holes.

Install the camshafts (page 9-26).

Rotate the camshafts by rotating the crankshaft clockwise several times.
Recheck the valve clearance.

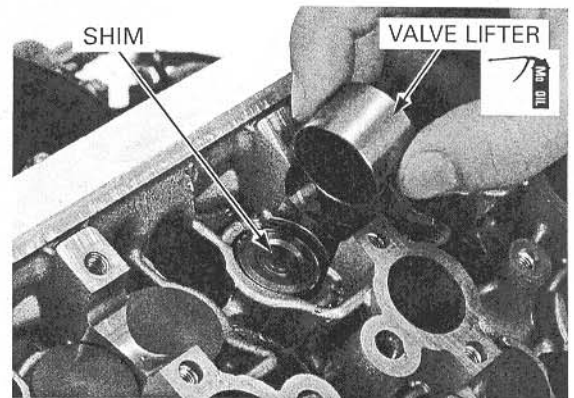

Check that the O-ring is in good condition, replace if necessary.

Apply grease the timing hole cap threads.
Tighten the timing hole cap to the specified torque.

TORQUE: 18 N·m (1.8 kgf·m, 13 lbf·ft)

Install the removed parts in the reverse order of removal.

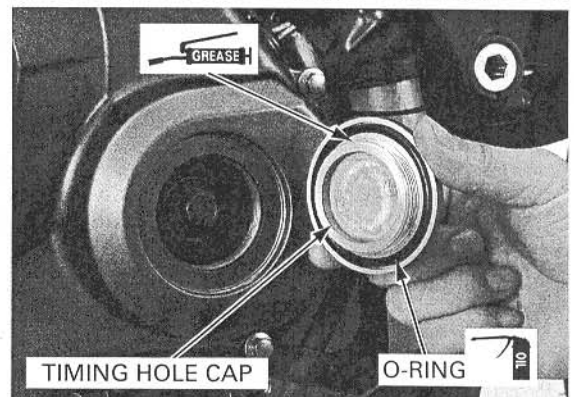

ENGINE OIL/OIL FILTER

OIL LEVEL INSPECTION

Start the engine and let it idle for 3 – 5 minutes.
Stop the engine and wait 2 – 3 minutes.
Hold the motorcycle in an upright position.
Check the oil level through the inspection window.



If the level is below the lower level line, remove the oil filler cap and fill the crankcase with the recommended oil up to the upper level line as following procedures.

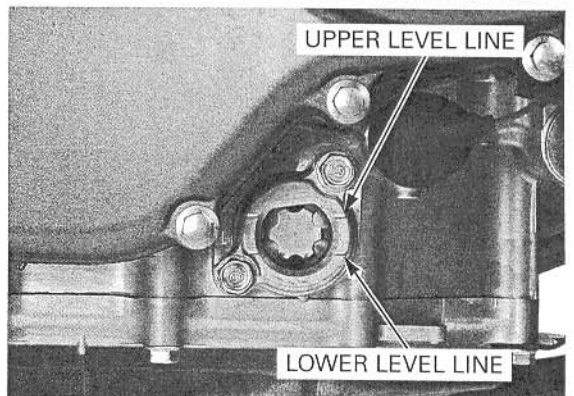

MAINTENANCE

Remove the oil filler cap.

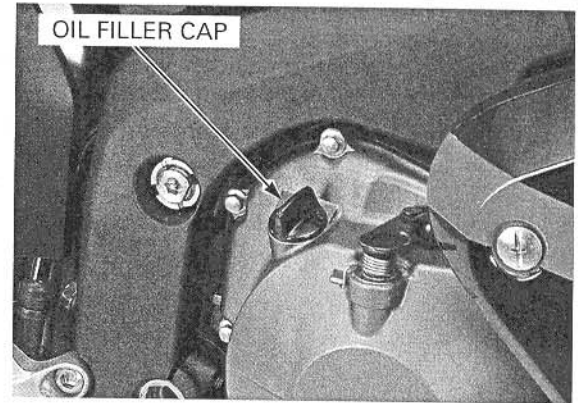

Fill the recommended engine oil up to the upper level line.

Other viscosities shown in the chart may be used when the average temperature in your riding area is within the indicated range.

RECOMMENDED ENGINE OIL:

Pro Honda GN4 or HP4 (without molybdenum additives)
4-stroke oil (U.S.A. & Canada) or Honda 4-stroke oil (Canada only), or an equivalent motorcycle oil
API service classification: SG or higher except oils labeled as energy conserving on the circular API service label
JASO T 903 standard: MA
Viscosity: SAE 10W-40

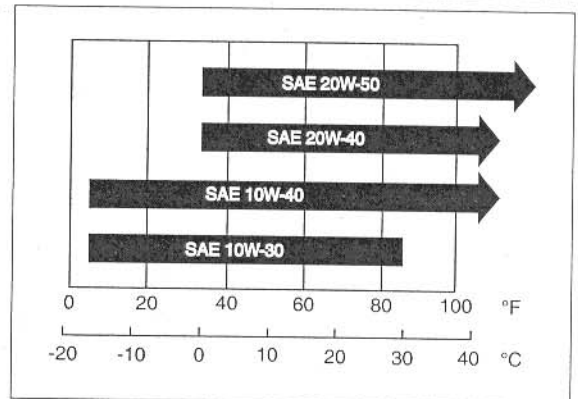

Reinstall the oil filler cap.

ENGINE OIL & FILTER CHANGE

Change the engine oil with the warm oil with the warm and the motorcycle on level ground to assure complete draining.

Start the engine and let it idle for 3 – 5 minutes. Stop the engine and wait 2 – 3 minutes. Hold the motorcycle in an upright position.

Remove the lower cowls (page 3-6).

Remove the oil filler cap.

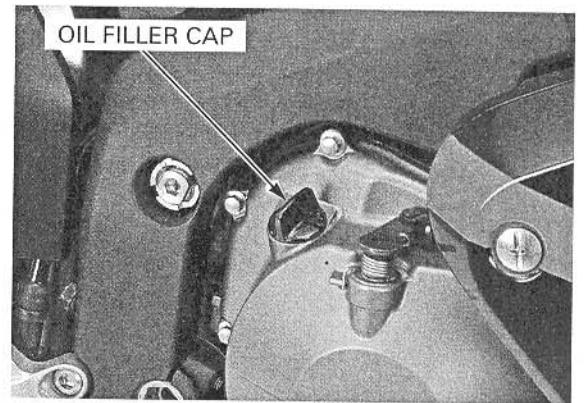

Remove the drain bolt and sealing washer, drain the oil completely.

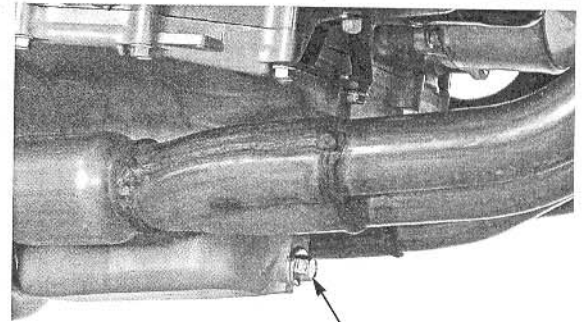

OIL DRAIN BOLT/SEALING WASHER

Remove the radiator reserve tank (page 7-17).
 Remove and discard the oil filter cartridge using the special tool.

TOOL:
Oil filter wrench 07HAA-PJ70101 or
 07HAA-PJ70100
 (U.S.A. only)

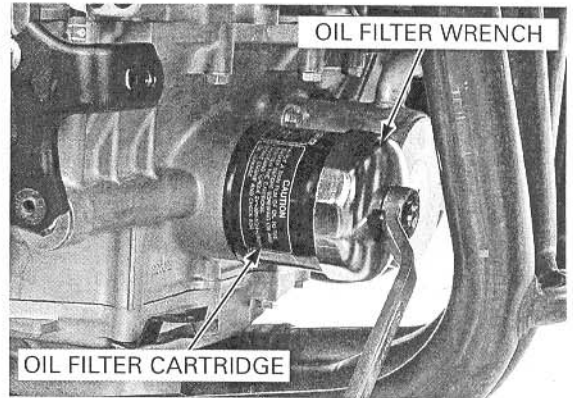

Check that the sealing washer on the drain bolt is in good condition, and replace if necessary. Install and tighten the drain bolt.

TORQUE: 29 N·m (3.0 kgf·m, 22 lbf·ft)

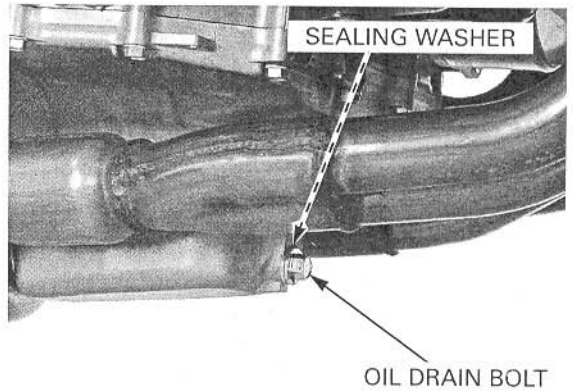

Apply clean engine oil to the new oil filter O-ring.

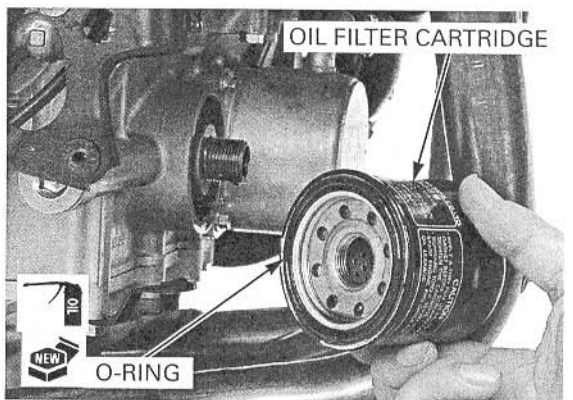

Install the new oil filter and tighten it to the specified torque.

TOOL:
Oil filter wrench 07HAA-PJ70101

TORQUE: 26 N·m (2.7 kgf·m, 20 lbf·ft)

Install the radiator reserve tank (page 7-18).

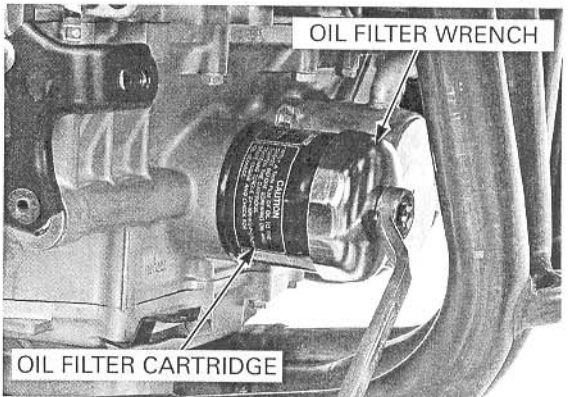

MAINTENANCE

Fill the crankcase with recommended engine oil.

OIL CAPACITY:

- 2.6 liter (2.7 US qt, 2.3 Imp qt) after draining
- 2.9 liter (3.1 US qt, 2.6 Imp qt) after oil filter change

Check that the O-ring on the oil filler cap is in good condition, and replace it if necessary. Install the oil filler cap.

Start the engine and let it idle for 3 – 5 minutes. Stop the engine and wait 2 – 3 minutes and recheck the oil level.

Make sure there are no oil leaks.

Install the lower cowls (page 3-6).

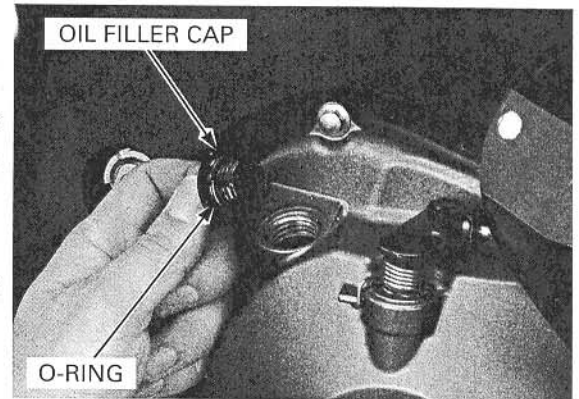

ENGINE IDLE SPEED

- Inspect and adjust the idle speed after all other engine maintenance items have been performed and are within specification.
- The engine must be warm for accurate idle speed inspection and adjustment.

Warm the engine for about 10 minutes.

Turn the throttle stop screw as required to obtain the specified idle speed.

IDLE SPEED: 1,300 ± 100 rpm

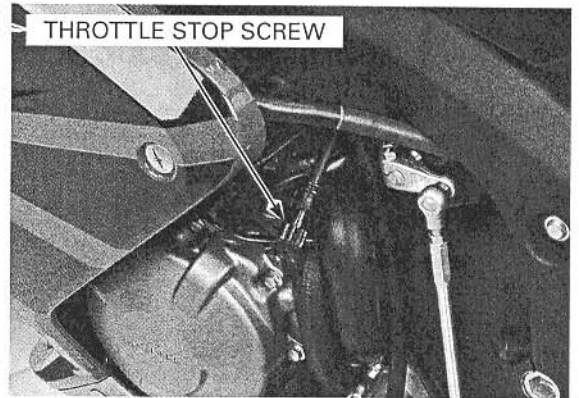

RADIATOR COOLANT

Check the coolant level of the reserve tank with the engine running at normal operating temperature.

The level should be between the "UPPER" and "LOWER" level lines.

If necessary, add recommended coolant.

RECOMMENDED ANTIFREEZE:

Pro Honda HP Coolant or an equivalent high quality ethylene glycol antifreeze containing corrosion protection inhibitors.

Remove the following:

- Lower cowls (page 3-6)
- Middle cowls (page 3-7)

Remove the reserve tank filler cap and fill to the "UPPER" level line with 1:1 mixture of distilled water and antifreeze.

Reinstall the filler cap.

Install the following:

- Middle cowls (page 3-8)
- Lower cowls (page 3-6)

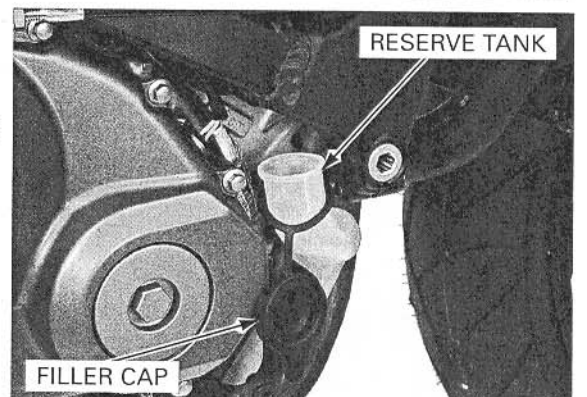
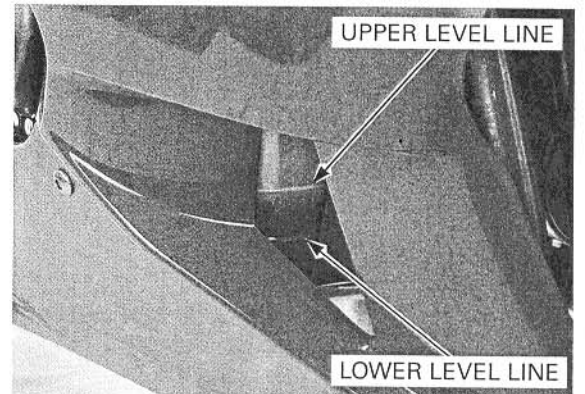

COOLING SYSTEM

Remove the following:

- Lower cowls (page 3-6)
- Middle cowls (page 3-7)

Check the radiator air passages for clogging or damage.

Straighten bent fins, and remove insects, mud or other obstructions with compressed air or low water pressure.

Replace the radiator if the air flow is restricted over more than 20% of the radiating surface.

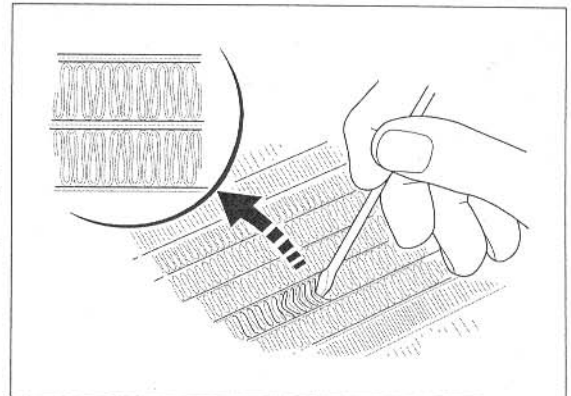

Inspect the radiator hoses for cracks or deterioration, and replace them if necessary.

Check the tightness of all hose clamps and fasteners.

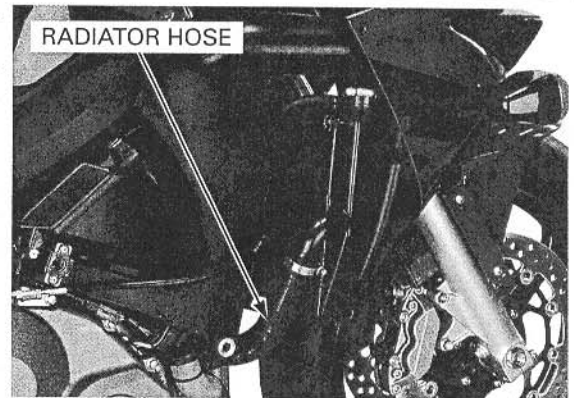

SECONDARY AIR SUPPLY SYSTEM

- This model is equipped built-in secondary air supply system. The pulse secondary air supply system is located on the cylinder head cover.
- The secondary air supply system introduces filtered air into exhaust gases in the exhaust port. The secondary air is drawn into the exhaust port whenever there is negative pressure pulse in the exhaust system. This charged secondary air promotes burning of the unburned exhaust gases and changes a considerable amount of hydrocarbons and carbon monoxide into relatively harmless carbon dioxide and water.

Remove the air cleaner housing (page 6-64).

If the hoses show any signs of heat damage, inspect the PAIR reed valves in the PAIR check valves for damage.

Check the PAIR (pulse secondary air injection) hoses between the PAIR control solenoid valve and cylinder head cover for deterioration, damage or loose connections. Make sure that the hoses are not cracked.

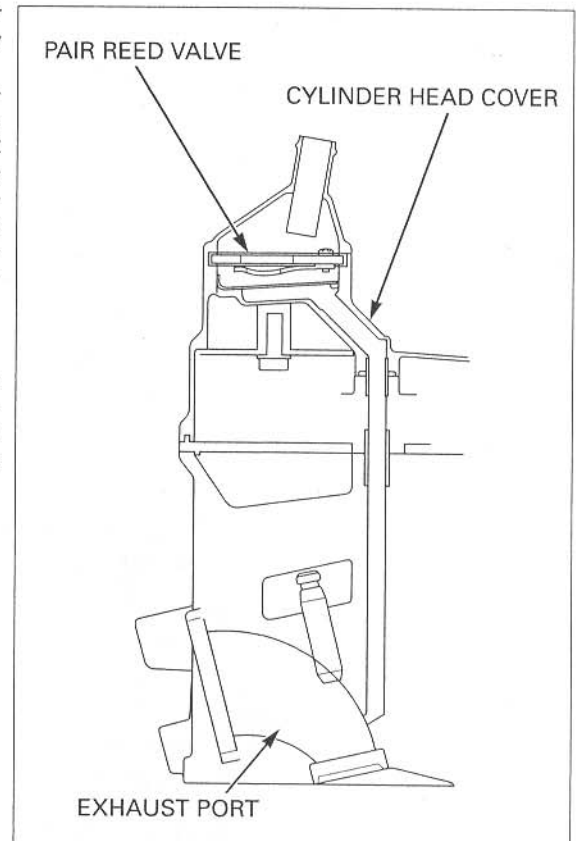

MAINTENANCE

Check the air suction hose between the air cleaner housing and PAIR control solenoid valve for deterioration, damage or loose connections. Make sure that the hoses are not kinked, pinched or cracked.

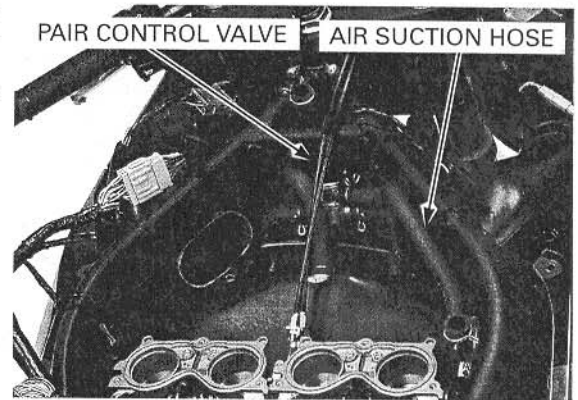

EVAPORATIVE EMISSION CONTROL SYSTEM (CALIFORNIA TYPE ONLY)

Check the hoses between the fuel tank, EVAP canister, EVAP purge control solenoid valve for deterioration, damage or loose connectors.

Check the EVAP canister for cracks or other damage.

Refer to the Vacuum Hose Routing Diagram Label (page 1-39) and Cable & Harness Routing (page 1-33) for hose connections.

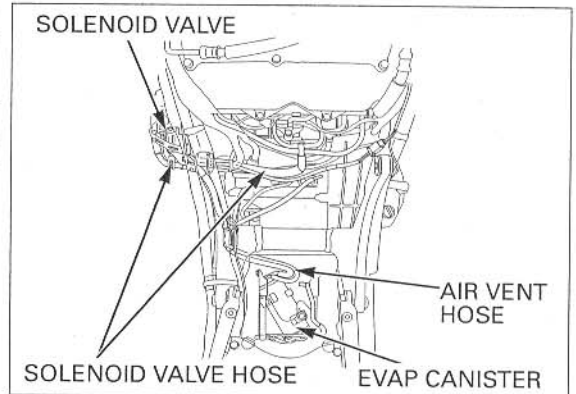

REMOVAL/INSTALLATION

Disconnect the EVAP purge control solenoid valve hose and fuel tank air vent hose. Remove the four bolts and EVAP canister.

Install the EVAP canister in the reverse order of removal.

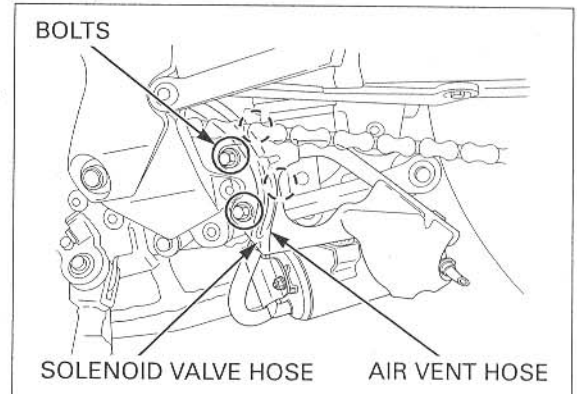

DRIVE CHAIN

Never inspect and adjust the drive chain while the engine is running.

DRIVE CHAIN SLACK INSPECTION

Turn the ignition switch OFF, place the motorcycle on its side stand and shift the transmission into neutral.

Check the slack in the drive chain lower run midway between the sprockets.

CHAIN SLACK: 25 – 35 mm (1 – 1-3/8 in)

NOTICE

Excessive chain slack, 50 mm (2.0 in) or more, may damage the frame.

Lubricate the drive chain with #80 – 90 gear oil or chain lubricant designed specifically for use with O-ring chains. Wipe off the excess oil or chain lubricant.

ADJUSTMENT

Loosen the rear axle nut.

Turn both adjusting bolts until the correct drive chain slack is obtained.

Make sure the index marks on both adjusting plates are aligned with the end of the swingarm.

Tighten the rear axle nut to the specified torque.

TORQUE: 113 N·m (11.5 kgf·m, 83 lbf·ft)

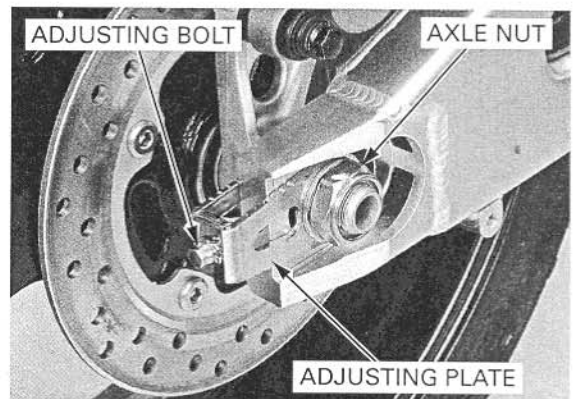
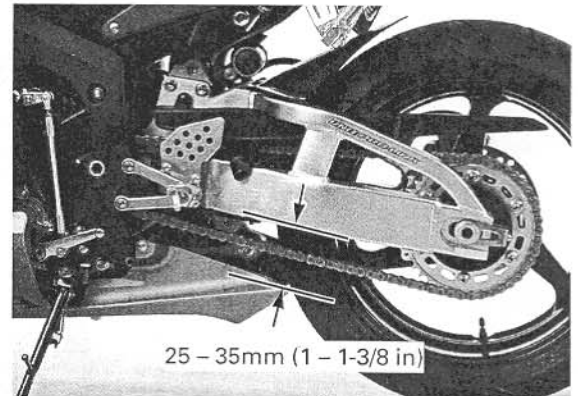

Recheck the drive chain slack and free wheel rotation.

Lubricate the drive chain with #80 – 90 gear oil or drive chain lubricant designed specifically for use with O-ring chains. Wipe off the excess oil or chain lubricant.

Check the drive chain wear indicator label attached on the left drive chain adjusting plate.

If the swingarm index mark reaches red zone of the indicator label, replace the drive chain with a new one (page 4-23).

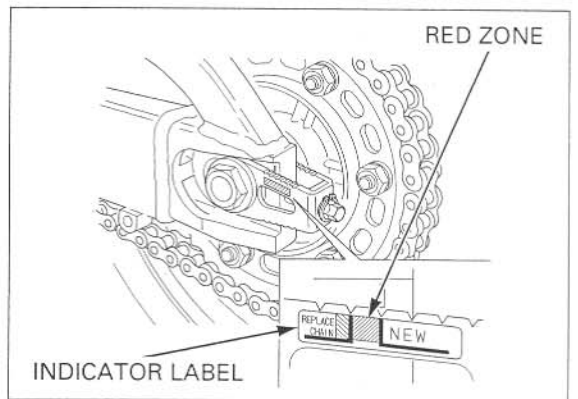

CLEANING AND LUBRICATION

Clean the chain with non-flammable or high flash point solvent and wipe it dry.

Be sure the chain has dried completely before lubricating.

Inspect the drive chain for possible damage or wear. Replace any chain that has damaged rollers, loose fitting links, or otherwise appears unserviceable.

Installing a new chain on badly worn sprockets will cause the new chain to wear quickly.

Inspect and replace sprocket as necessary.

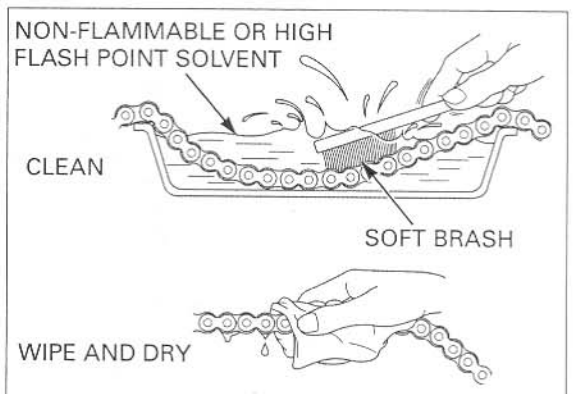

MAINTENANCE

Lubricate the drive chain with #80 – 90 gear oil or drive chain lubricant designed specifically for use with O-ring chains. Wipe off the excess oil or chain lubricant.

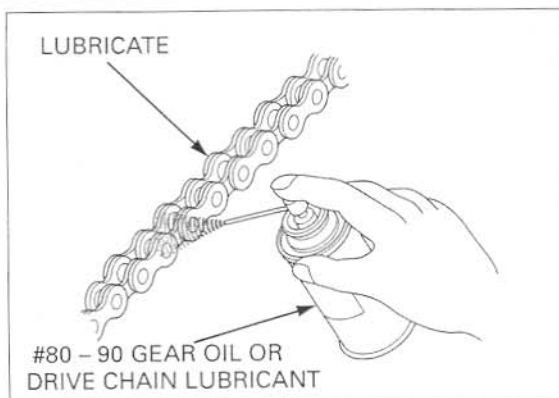

SPROCKET INSPECTION

Inspect the drive and driven sprocket teeth for wear or damage, replace if necessary.

Never use a new drive chain on worn sprockets.

Both chain and sprockets must be in good condition, or the new replacement chain will wear rapidly.

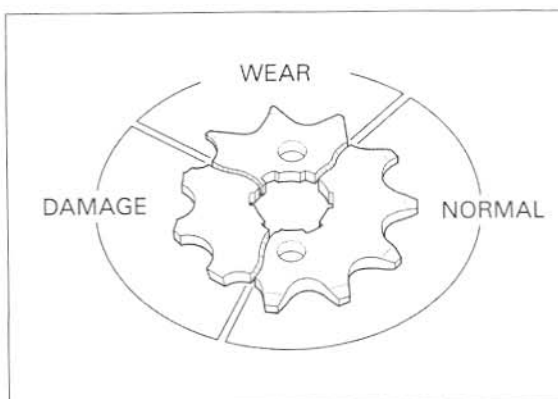

Check the attaching bolts and nuts on the drive and driven sprockets.
If any are loose, torque them.

TORQUE:

Drive sprocket special bolt: 54 N·m (5.5 kg·m, 40 lbf·ft)

Final driven sprocket nut: 64 N·m (6.5 kgf·m, 47 lbf·ft)

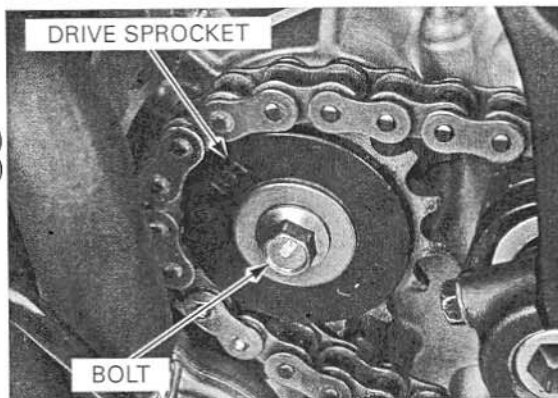

REPLACEMENT

This motorcycle uses a drive chain with a staked master link.

Loosen the drive chain (page 4-21).

Assemble the special tool as shown.

TOOL:
Drive chain tool set

**07HMH-MR10103 or
07HMH-MR1010C
(U.S.A. only)**

When using the special tool, follow the manufacturer's instruction.

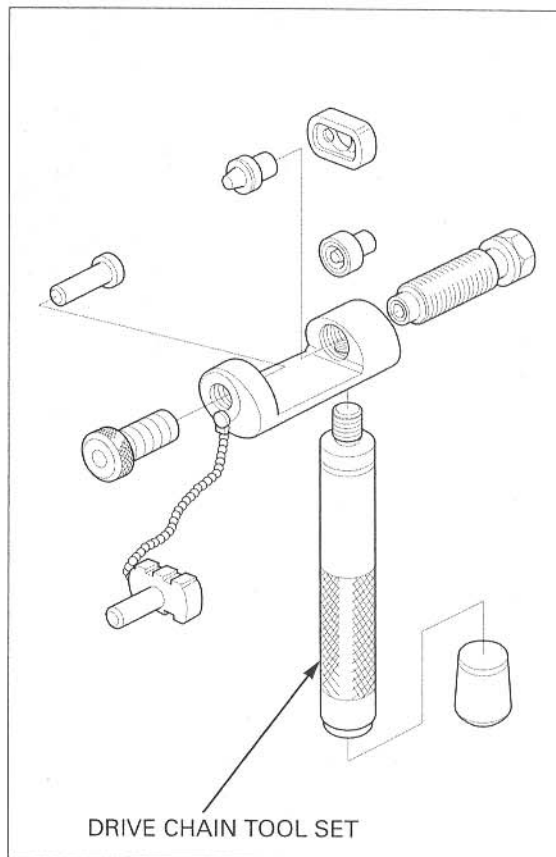

Locate the crimped pin ends of the master link from the outside of the chain, and remove the link with the drive chain tool set.

TOOL:
Drive chain tool set

**07HMH-MR10103 or
07HMH-MR1010C
(U.S.A. only)**

Remove the drive chain.

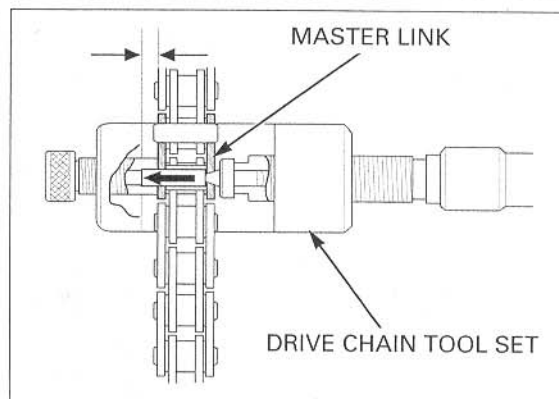

Include the master link when you count the drive chain links.

Remove the excess drive chain links from the new drive chain with the drive chain tool set.

STANDARD LINKS: 112 LINKS

REPLACEMENT CHAIN

DID: DID525HV-120ZB

RK: RK525ROZ1-120LJ-FZ

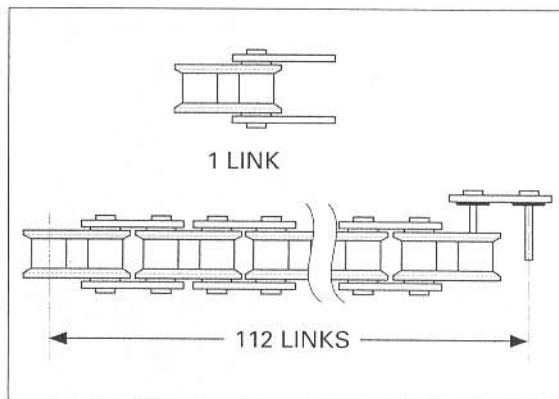

MAINTENANCE

- Never reuse the old drive chain, master link, master link plate and O-rings.

Insert the master link from the inside of the drive chain, and install the plate with the identification mark facing the outside.

Assemble the new master link, O-rings and plate.

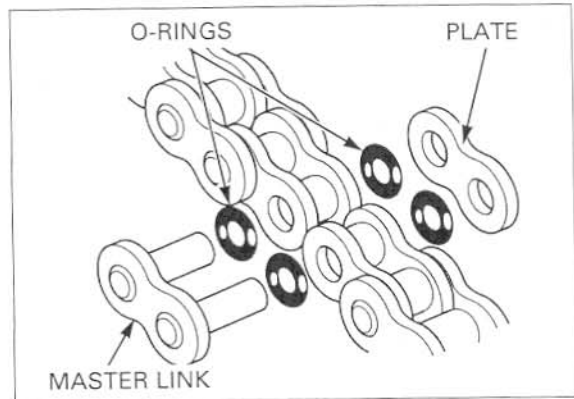

Assemble and set the drive chain tool set.

TOOL:

Drive chain tool set

07HMH-MR10103 or
07HMH-MR1010C
(U.S.A. only)

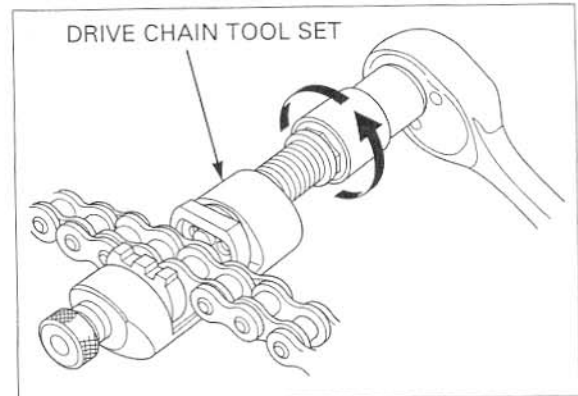

Make sure that the master link pins are installed properly.
Measure the master link pin length projected from the plate.

STANDARD LENGTH:

DID: 1.15 – 1.55 mm (0.045 – 0.061 in)

RK: 1.2 – 1.4 mm (0.05 – 0.06 in)

Stake the master link pins.

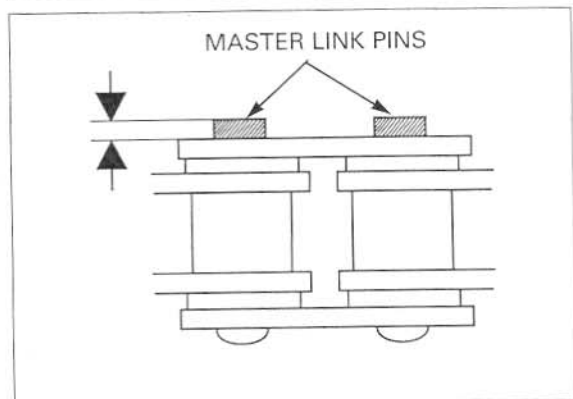

Make sure that the pins are staked properly by measuring the diameter of the staked area using a slide caliper.

DIAMETER OF THE STAKED AREA:

DID: 5.50 – 5.80 mm (0.217 – 0.228 in)

RK: 5.30 – 5.70 mm (0.208 – 0.224 in)

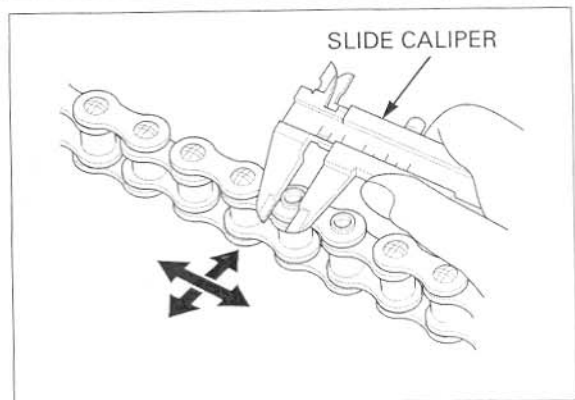

A drive chain with a clip-type master link must not be used.

After staking, check the staked area of the master link for cracks. If there is any cracking, replace the master link, O-rings and plate.

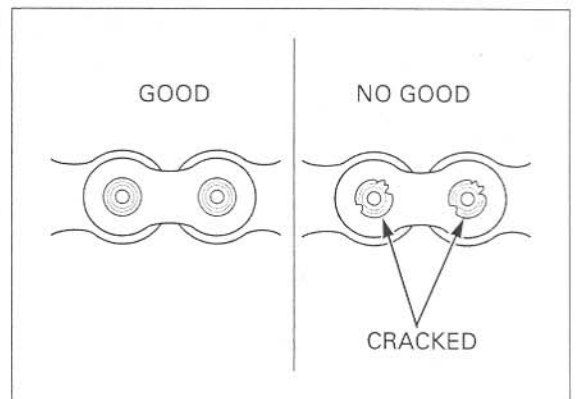

BRAKE FLUID

NOTICE

Spilled fluid can damage painted, plastic or rubber parts. Place a rag over these parts whenever the system is serviced.

- Do not mix different types of fluid, as they are not compatible with each other.
- Do not allow foreign material to enter the system when filling the reservoir.

When the fluid level is low, check the brake pads for wear (page 4-26). A low fluid level may be due to wear of the brake pads. If the brake pads are worn, the caliper piston is pushed out, and this accounts for a low reservoir level. If the brake pads are not worn and the fluid level is low, check entire system for leaks (page 4-26).

FRONT BRAKE

Turn the handlebar so that the reservoir is level and check the front brake fluid level. If the level is near the lower level line, check the brake pad wear (page 4-26).



REAR BRAKE

Remove the rear cowl (page 3-5).

Place the motorcycle on a level surface, and support it in an upright position.

Check the rear brake fluid level.

If the level is near the lower level line, check the brake pad wear (page 4-26).



MAINTENANCE

BRAKE PAD WEAR

FRONT BRAKE PADS

Check the brake pads for wear.
Replace the brake pads if either pad is worn to the bottom of wear limit groove.

Refer to page 16-9 for brake pad replacement.

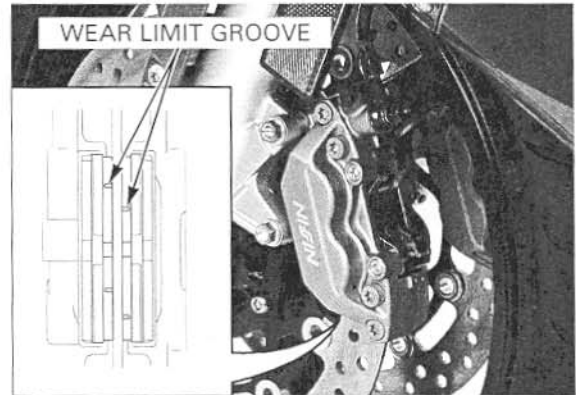

REAR BRAKE PADS

Check the brake pads for wear.
Replace the brake pads if either pad is worn to the bottom of wear limit groove.

Refer to page 16-11 for brake pad replacement.

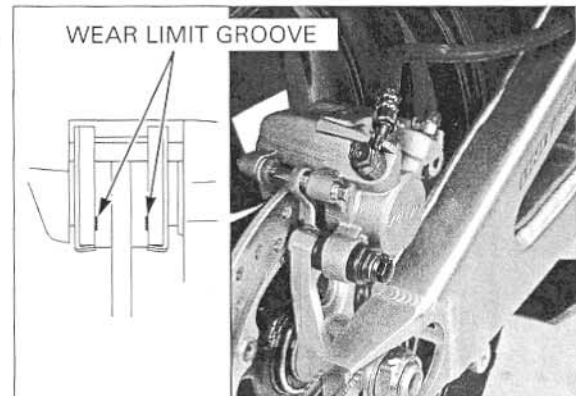

BRAKE SYSTEM

INSPECTION

Firmly apply the brake lever or pedal, and check that no air has entered the system.
If the lever or pedal feels soft or spongy when operated, bleed the air from the system (page 16-7).

Inspect the brake hose and fittings for deterioration, cracks and signs of leakage.
Tighten any loose fittings.
Replace hoses and fittings as required.

Refer to page 16-6 for brake bleeding procedures.

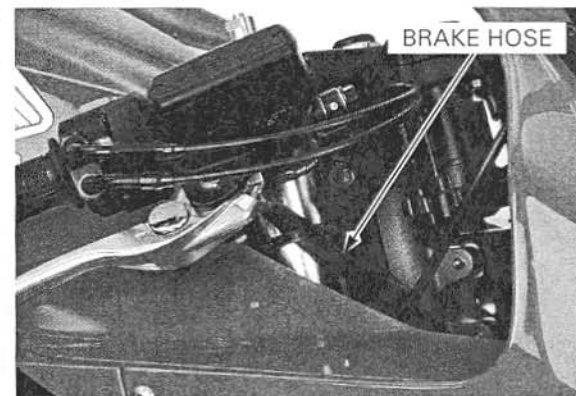

BRAKE LEVER ADJUSTMENT

Align the allow mark on the brake lever with the index number on the adjuster.

The distance between the top of the brake lever and the grip can be adjusted by turning the adjuster.

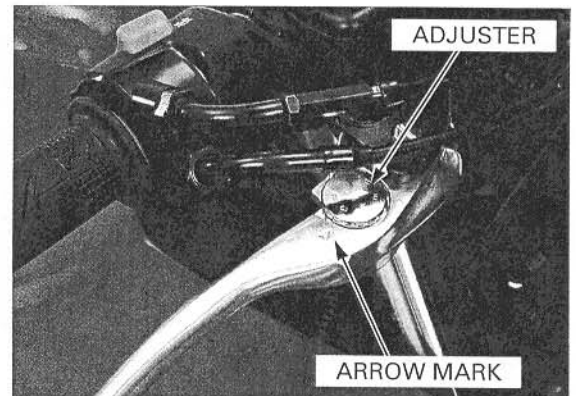

BRAKE PEDAL HEIGHT ADJUSTMENT

Loosen the lock nut and turn the push rod until the correct pedal height is obtained.

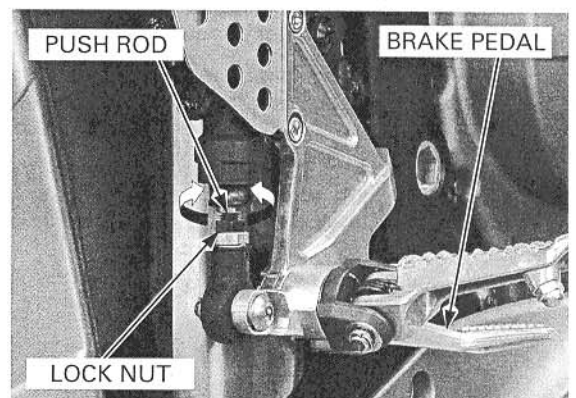

Make sure the push rod threads can be seen through the pedal joint hole. After adjustment, tighten the lock nut to the specified torque.

TORQUE: 18 N·m (1.8 kgf·m, 13 lbf·ft)

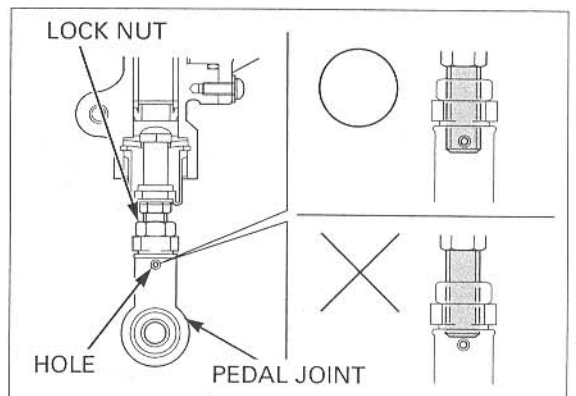

BRAKE LIGHT SWITCH

The front brake light switch does not require adjustment.

Adjust the brake light switch so that the brake light comes on just prior to the brake actually being engaged.

If the light fails to come on, adjust the switch so that the light comes on at the proper time.

Hold the switch body and turn the adjuster. Do not turn the switch body.

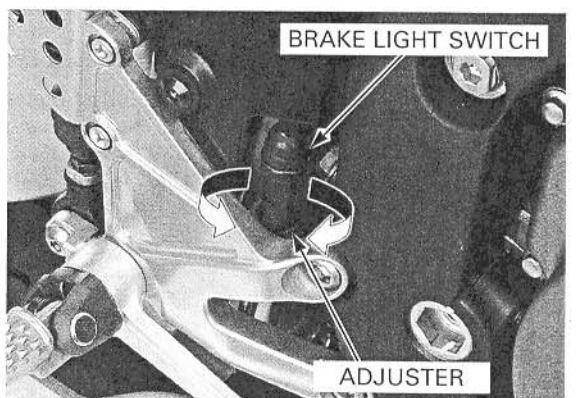

MAINTENANCE

HEADLIGHT AIM

Place the motorcycle on a level surface.

Adjust the headlight aim as specified by local laws and regulations.

Adjust the headlight aim vertically by turning the vertical beam adjusting screw. A clockwise rotation moves the beam up and counterclockwise rotation moves the beam down.

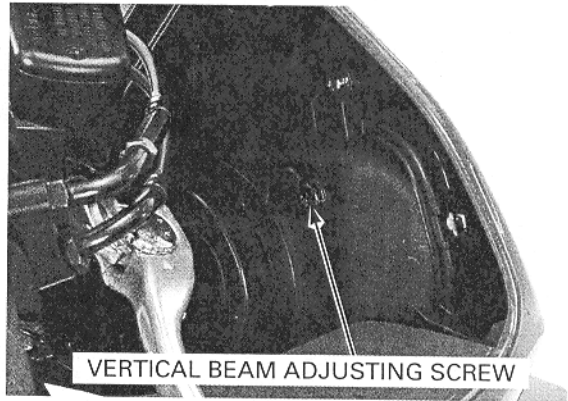

Adjust the headlight aim horizontally by turning the horizontal beam adjusting screw.

Left Headlight: A clockwise rotation moves the beam toward the right and counterclockwise rotation moves the beam toward the left side of the rider.

Right Headlight: A clockwise rotation moves the beam toward the left and counterclockwise rotation moves the beam toward the right side of the rider.

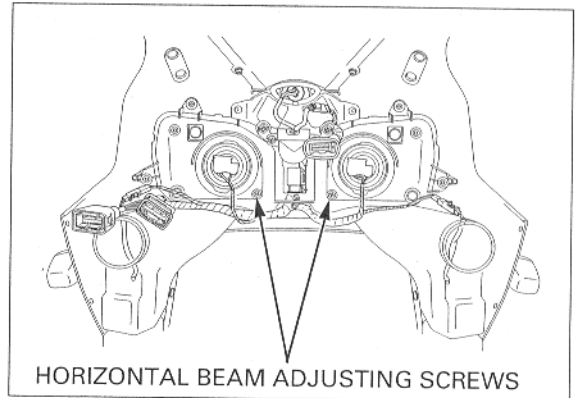

CLUTCH SYSTEM

Measure the clutch lever free play at the end of the clutch lever.

FREE PLAY: 10 – 20 mm (3/8 – 13/16 in)

10 – 20 mm (3/8 – 13/16 in)

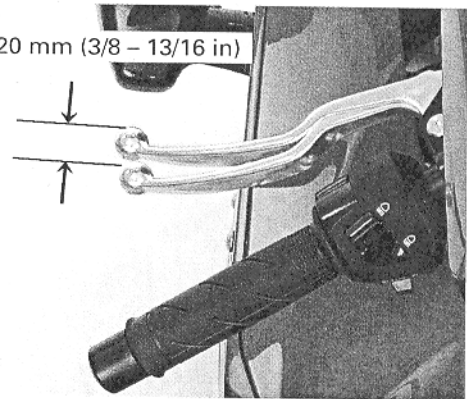

The adjuster may be damaged if it is positioned too far out, leaving minimal thread engagement.

Minor adjustment is made using the upper adjuster at the clutch lever.

Loosen the lock nut and turn the adjuster.

If the adjuster is threaded out near its limit and the correct free play cannot be obtained, turn the adjuster all the way in and back out one turn.

Tighten the lock nut while holding the adjuster and make a major adjustment as described as follow.

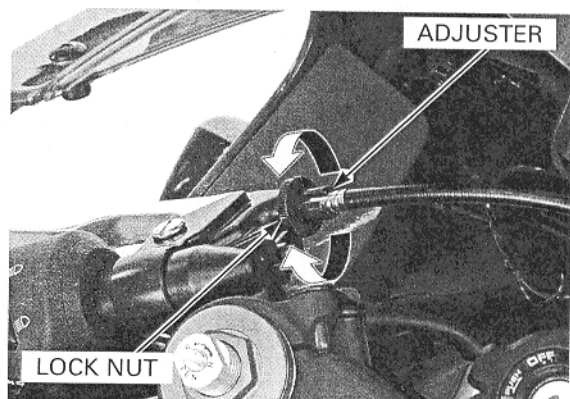

Major adjustment is performed at the clutch lifter lever.

Loosen the lock nut and turn the adjusting nut to adjust the free play.

Tighten the lock nut while holding the adjusting nut.

If proper free play cannot be obtained, or the clutch slips during test ride, disassemble and inspect the clutch (page 10-7).

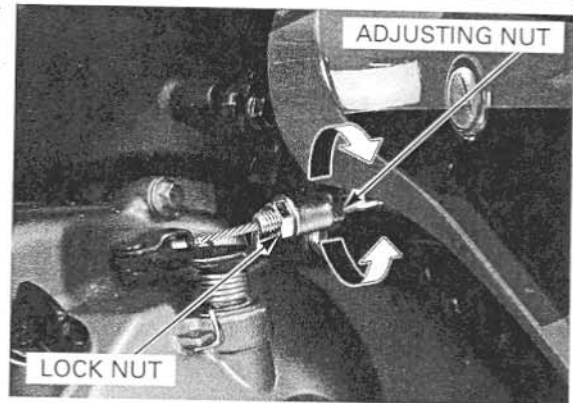

SIDE STAND

Support the motorcycle on a level surface.

Check the side stand spring for damage or loss of tension.

Check the side stand assembly for freedom of movement and lubricate the side stand pivot if necessary.

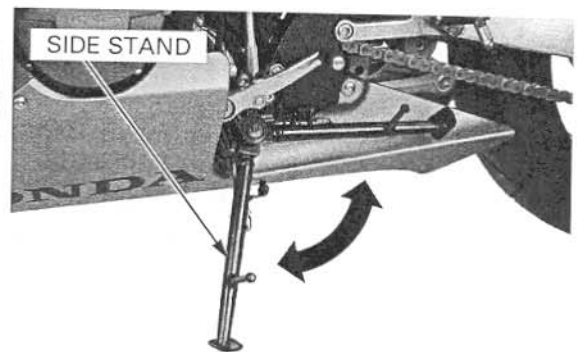

Check the side stand ignition cut-off system:

- Sit astride the motorcycle and raise the side stand.
- Start the engine with the transmission in neutral, then shift the transmission into gear, with the clutch lever squeezed.
- Move the side stand full down.
- The engine should stop as the side stand is lowered.

If there is a problem with the system, check the side stand switch (page 20-22).

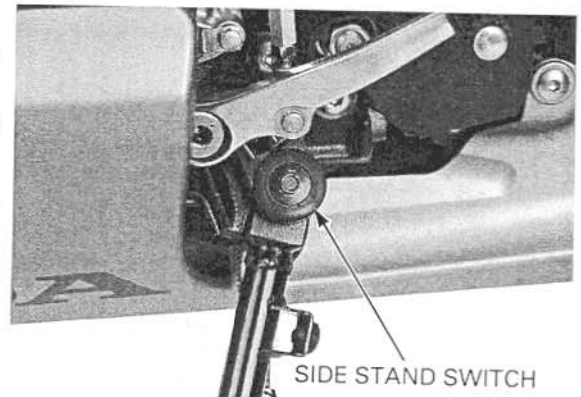

SUSPENSION

FRONT SUSPENSION INSPECTION

Check the action of the forks by operating the front brakes and compressing the front suspension several times.

Check the entire assembly for signs of leaks, damage or loose fasteners.

Loose, worn or damaged suspension parts impair motorcycles stability and control.

Replace damaged components which cannot be repaired.

Tighten all nuts and bolts.

Refer to page 14-18 for fork service.



MAINTENANCE

Check for worn steering stem bearings by grabbing the front fork leg and attempting to move the front fork side to side.

Replace the bearings if any looseness is noted.

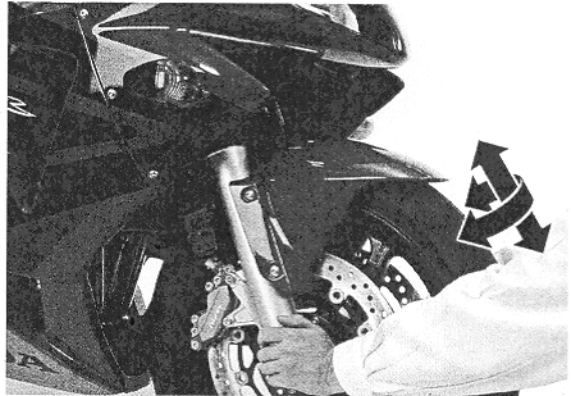

FRONT SUSPENSION ADJUSTMENT

SPRING PRE-LOAD ADJUSTER

Spring pre-load can be adjusted by turning the adjuster.

TURN CLOCKWISE:

Increase the spring pre-load

TURN COUNTERCLOCKWISE:

Decrease the spring pre-load

PRE-LOAD ADJUSTER ADJUSTABLE RANGE:

6 – 21 mm (0.2 – 0.8 in) from top of fork bolt

PRE-LOAD ADJUSTER STANDARD POSITION:

14 mm (0.6 in): 4th groove from top of fork bolt

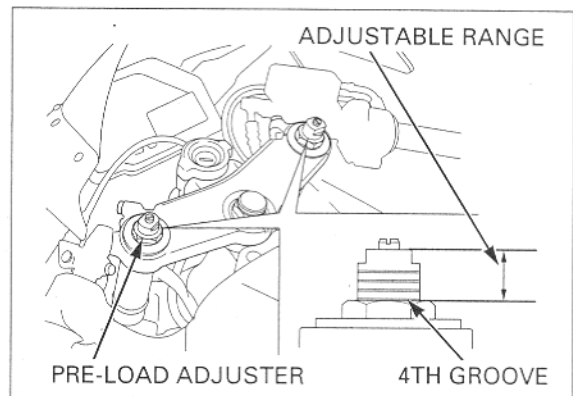

COMPRESSION AND REBOUND DAMPING ADJUSTERS

NOTICE

Do not turn the adjusters more than the given positions or the adjusters may be damaged.

- All damping adjustments are referenced from the full hard position.
- Be sure that the rebound and compression adjusters are firmly located in a detent, and not between positions.

To adjust both sides equally, set the right and left damping adjusters to the same position.

The compression and rebound damping can be adjusted by turning the adjusters.

DIRECTION H: Increase the damping force

DIRECTION S: Decrease the damping force

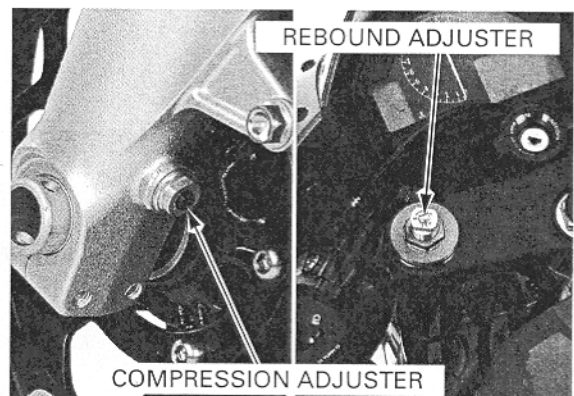

Turn the compression adjuster clockwise until it stops (full hard position), then turn the adjuster counterclockwise.

COMPRESSION ADJUSTER STANDARD POSITION:
2 turns out from full hard

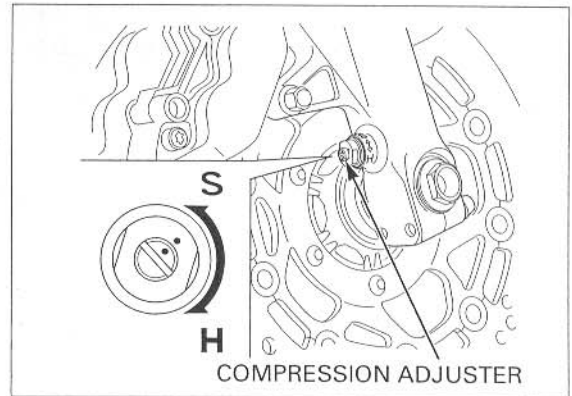

Turn the rebound adjuster clockwise until it stops (full hard position), then turn the adjuster counterclockwise.

REBOUND ADJUSTER STANDARD POSITION:
2 - 1/2 turns out from full hard

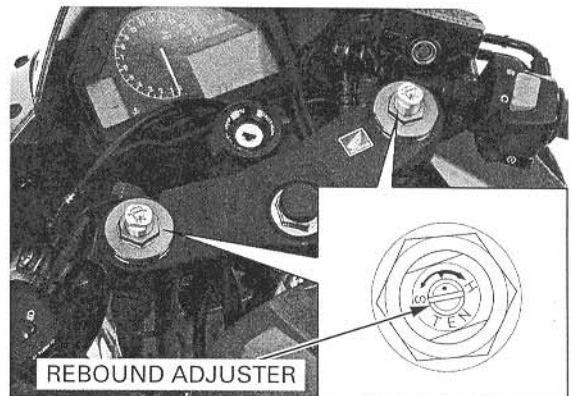

REAR SUSPENSION INSPECTION

Support the motorcycle securely and raise the rear wheel off the ground.

Check for worn swingarm bearings by grabbing the rear end of the swingarm and attempting to move the swingarm side to side.

Replace the bearings if any are looseness is noted.



Check the action of the shock absorber by compressing it several times.

Check the entire shock absorber assembly for signs of leaks, damage or loose fasteners.

Replace damaged components which cannot be repaired.

Tighten all nuts and bolts.

Refer to page 15-15 for shock absorber service.

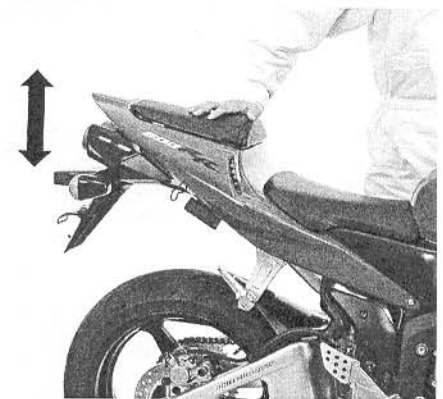

REAR SUSPENSION ADJUSTMENT

COMPRESSION AND REBOUND DAMPING ADJUSTERS

NOTICE

Do not turn the adjusters more than the given positions or the adjusters may be damaged.

- All damping adjustments are referenced from the full hard position.

The compression and rebound damping can be adjusted by turning the adjusters.

DIRECTION H: Increase the damping force
DIRECTION S: Decrease the damping force

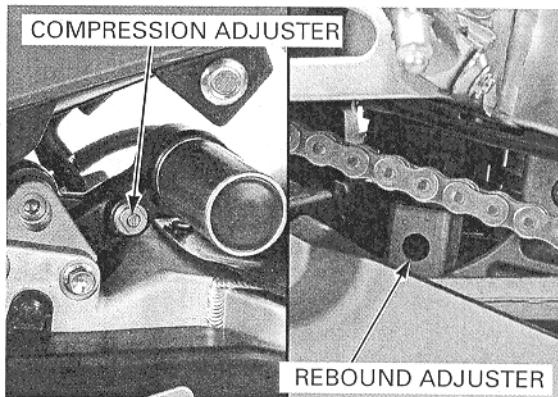

Turn the compression adjuster clockwise until it stops (full hard position), then turn the adjuster counterclockwise.

COMPRESSION ADJUSTER STANDARD POSITION:
7 clicks out from full hard

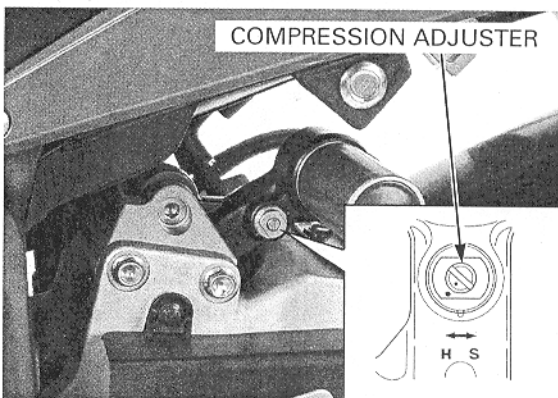

Turn the rebound adjuster clockwise until it stops (full hard position), then turn the adjuster counterclockwise.

REBOUND ADJUSTER STANDARD POSITION:
1 - 3/4 turns out from full hard

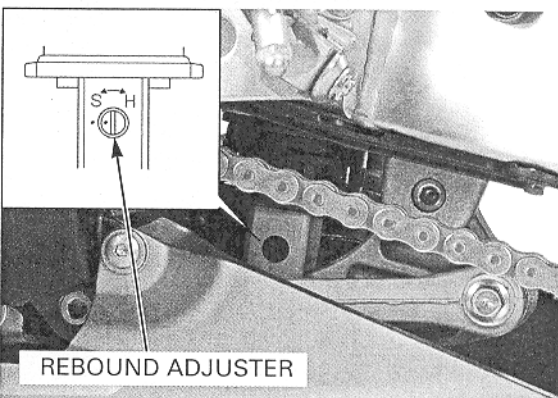

NUTS, BOLTS, FASTENERS

Check that all chassis nuts and bolts are tightened to their correct torque values (page 1-12).
Check that all safety clips, hose clamps and cable stays are in place and properly secured.

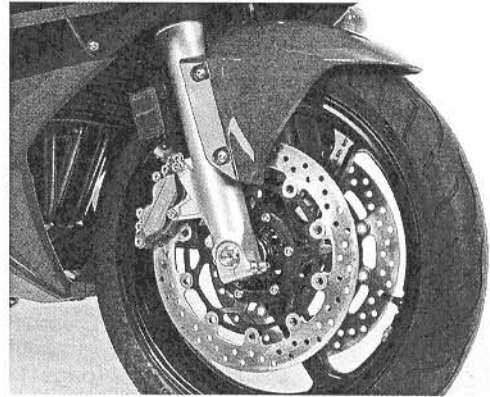

WHEELS/TIRES

Support the motorcycle securely and raise the front wheel off the ground.
Hold the front fork leg and move the front wheel sideways with force to see if the wheel bearings are worn.

Refer to page 14-12 for front wheel service.

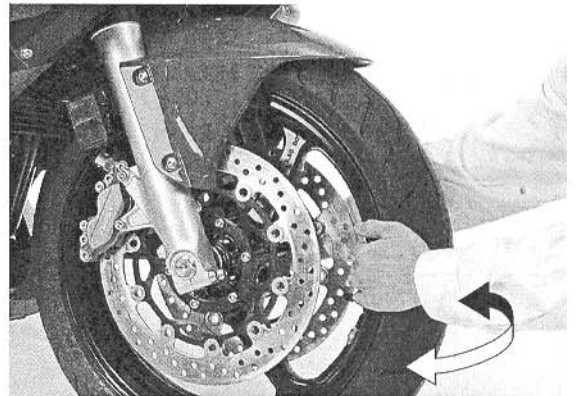

Support the motorcycle securely and raise the rear wheel off the ground.
Hold the swingarm and move the rear wheel sideways with force to see if the wheel bearings are worn.

Refer to page 15-8 for rear wheel service.

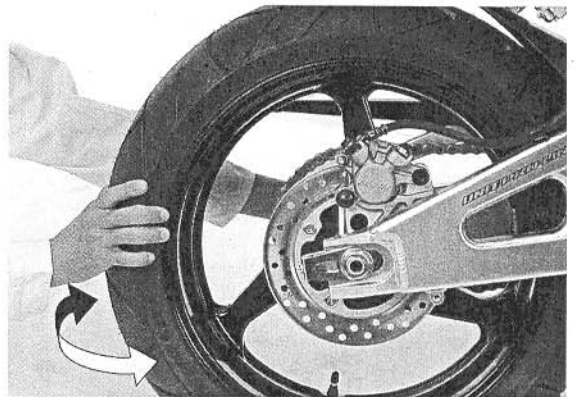

MAINTENANCE

Tire pressure should be checked when the tires are COLD.

RECOMMENDED TIRE PRESSURE AND TIRE SIZE:

		FRONT	REAR
Tire pressure kPa (kgf/cm ² , psi)		250 (2.50, 36)	290 (2.90, 42)
Tire size		120/70 ZR 17 M/C (58W)	180/55 ZR 17 M/C (73W)
Tire brand	Bridgestone	BT012F RADIAL G	BT012R RADIAL L
	Dunlop	D208FK	D208K
	Michelin	Pilot SPORT E	Pilot SPORT E

Check the tires for cuts, embedded nails, or other damage.

Check the front wheel (page 14-12) and rear wheel (page 15-8) for trueness.

Measure the tread depth at the center of the tires. Replace the tires when the tread depth reaches the following limits.

MINIMUM TREAD DEPTH:

FRONT: 1.5 mm (0.06 in)

REAR: 2.0 mm (0.08 in)

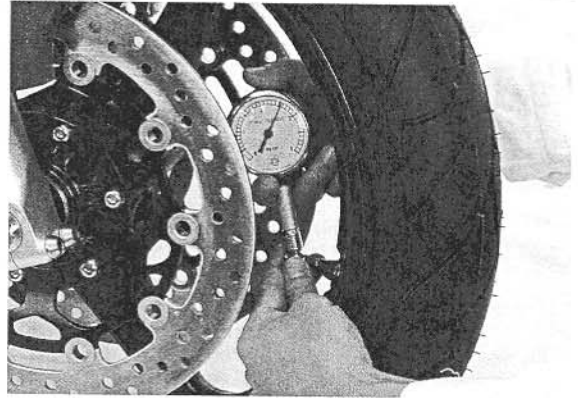

STEERING HEAD BEARINGS

Check that the control cables do not interfere with handlebar rotation.

Support the motorcycle securely and raise the front wheel off the ground.

Check that the handlebar moves freely from side to side.

If the handlebar moves unevenly, binds, or has vertical movement, inspect the steering head bearings (page 14-27).



5. LUBRICATION SYSTEM

LUBRICATION SYSTEM DIAGRAM	5-2	OIL STRAINER/PRESSURE RELIEF VALVE..	5-6
SERVICE INFORMATION	5-3	OIL PUMP.....	5-8
TROUBLE SHOOTING.....	5-4	OIL COOLER.....	5-12
OIL PRESSURE INSPECTION.....	5-5		

LUBRICATION SYSTEM DIAGRAM

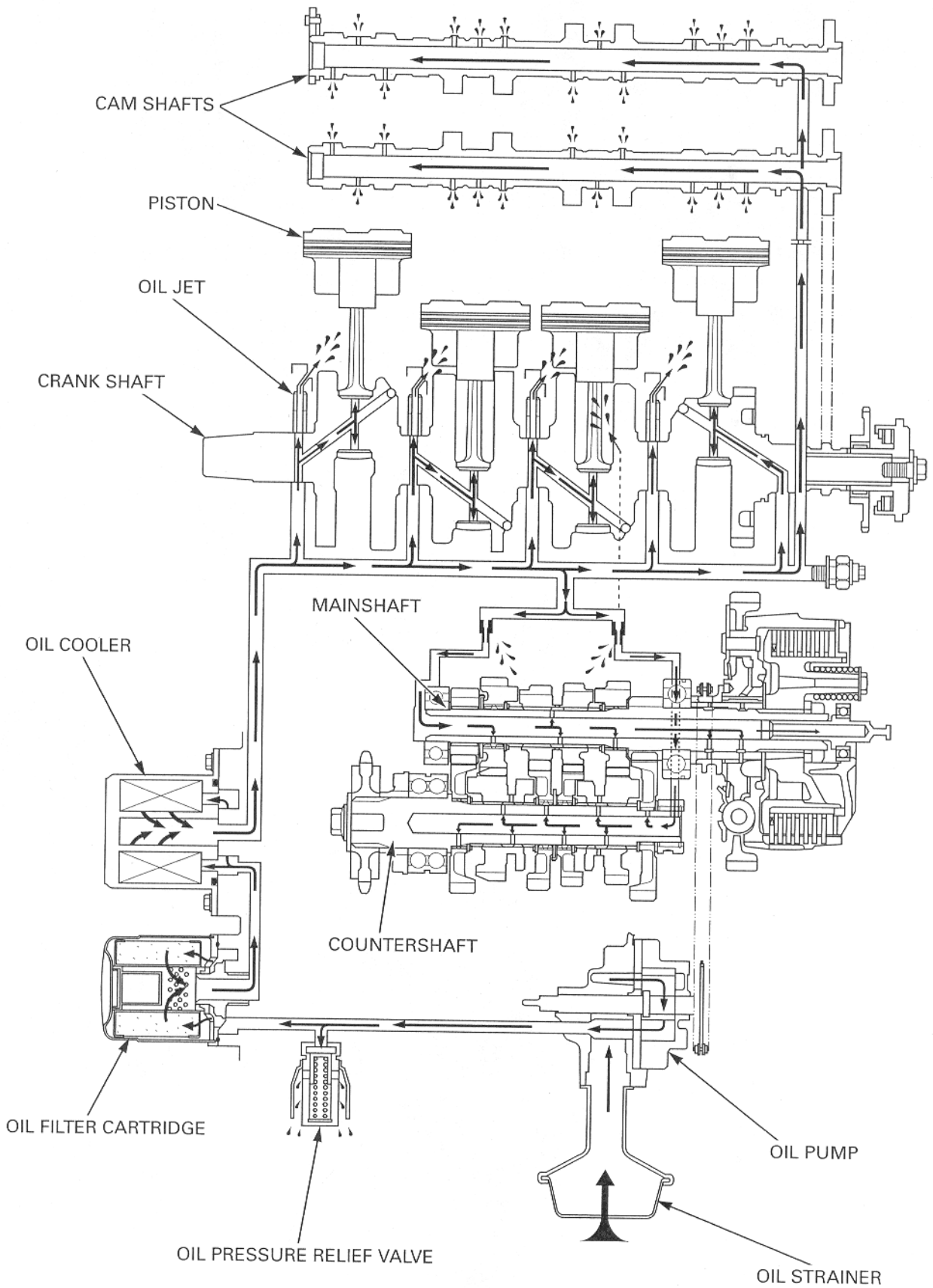

SERVICE INFORMATION

GENERAL

⚠ CAUTION

Used engine oil may cause skin cancer if repeatedly left in contact with the skin for prolonged periods. Although this is unlikely unless you handle used oil on a daily basis, it is still advisable to thoroughly wash your hands with soap and water as soon as possible after handling used oil.

- The oil pump can be serviced with the engine installed in the frame.
- The service procedures in this section must be performed with the engine oil drained.
- When removing and installing the oil pump, use care not to allow dust or dirt to enter the engine.
- If any portion of the oil pump is worn beyond the specified service limits, replace the oil pump as an assembly.
- After the oil pump has been installed, check that there are no oil leaks and that oil pressure is correct.

SPECIFICATIONS

ITEM		STANDARD	SERVICE LIMIT
Engine oil capacity	After draining	2.6 liter (2.7 US qt, 2.3 Imp qt)	–
	After oil filter change	2.9 liter (3.1 US qt, 2.6 Imp qt)	–
	After disassembly	3.5 liter (3.7 US qt, 3.1 Imp qt)	–
Recommended engine oil		Pro Honda GN4 or HP4 (with out molybdenum additives) 4-stroke oil (U.S.A. & Canada) or Honda 4-stroke oil (Canada only), equivalent motorcycle oil API service classification SG, or higher except oils labeled as energy conserving on the circular API service label JASO T 903 standard: MA Viscosity: SAE 10W – 40	–
Oil pressure at oil pressure switch		540 kPa (5.5 kgf/cm ² , 78 psi) at 6,000 rpm/(80°C/176°F)	–
Oil pump	Tip clearance	0.15 (0.006)	0.20 (0.008)
	Body clearance	0.15 – 0.21 (0.006 – 0.008)	0.35 (0.014)
	Side clearance	0.04 – 0.09 (0.002 – 0.004)	0.17 (0.007)

TORQUE VALUES

Oil pressure switch	12 N·m (1.2 kgf·m, 9 lbf·ft)	Apply sealant to the threads
Oil pressure switch wire terminal screw	2.0 N·m (0.2 kgf·m, 1.4 lbf·ft)	
Oil pump assembly flange bolt	7.8 N·m (0.8 kgf·m, 5.8 lbf·ft)	CT bolt
Engine oil filter cartridge	26 N·m (2.7 kgf·m, 20 lbf·ft)	Apply clean engine oil to the O-ring
Engine oil drain bolt	29 N·m (3.0 kgf·m, 22 lbf·ft)	
Oil pump driven sprocket bolt	15 N·m (1.5 kgf·m, 11 lbf·ft)	Apply a locking agent to the threads

LUBRICATION SYSTEM

TOOLS

Oil pressure gauge set
07506-300001

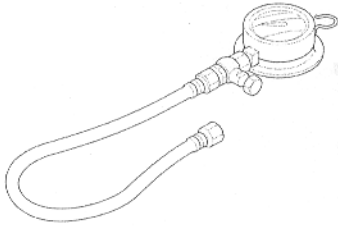

or equivalent commercially available in U.S.A.

Oil pressure gauge attachment
07406-0030000

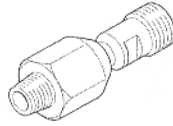

or equivalent commercially available in U.S.A.

TROUBLE SHOOTING

Oil level too low

- Oil consumption
- External oil leak
- Worn piston rings
- Improperly installed piston rings
- Worn cylinders
- Worn valve stem seals
- Worn valve guide

Low oil pressure

- Oil level low
- Clogged oil strainer
- Internal oil leak
- Incorrect oil being used

No oil pressure

- Oil level too low
- Oil pressure relief valve stuck open
- Broken oil pump drive chain
- Broken oil pump drive or driven sprocket
- Damaged oil pump
- Internal oil leak

High oil pressure

- Oil pressure relief valve stuck closed
- Clogged oil filter, oil cooler gallery or metering orifice
- Incorrect oil being used

Oil contamination

- Oil or filter not changed often enough
- Worn piston rings

Oil emulsification

- Blown cylinder head gasket
- Leaky coolant passage
- Entry of water

OIL PRESSURE INSPECTION

If the oil pressure indicator light remains on a few seconds, check the indicator system before checking the oil pressure.

Remove the lower cowls (page 3-6).

Remove the screw and disconnect the oil pressure switch wire.

Remove the oil pressure switch while holding the switch base.

Install the oil pressure gauge attachment to the switch base.

Connect the oil pressure gauge to the oil pressure gauge attachment.

TOOLS:

Oil pressure gauge set

07506-3000001 or equivalent commercially available in U.S.A.

Oil pressure gauge attachment

07406-0030000 or equivalent commercially available in U.S.A.

Check the oil level (page 4-15).

Warm the engine to normal operating temperature (approximately 80°C/176°F) and increase the engine speed to 6,000 min⁻¹ (rpm) and read the oil pressure.

OIL PRESSURE:

540 kPa (5.5 kgf/cm², 78 psi) at 6,000 rpm/ (80°C/176°F)

Stop the engine and remove the tools.

Apply a sealant to the oil pressure switch threads as shown.

Install and tighten the oil pressure switch to the specified torque while holding the switch base.

TORQUE: 12 N·m (1.2 kgf·m, 9 lbf·ft)

Connect the oil pressure switch wire terminal to the switch and tighten the screw to the specified torque.

TORQUE: 2.0 N·m (0.2 kgf·m, 1.4 lbf·ft)

Install the dust cover.

Install the lower cowls (page 3-6).

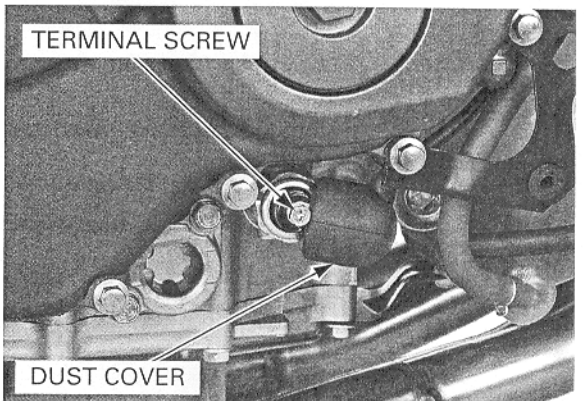
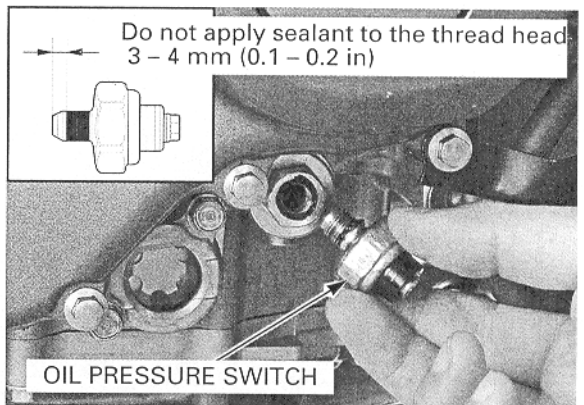
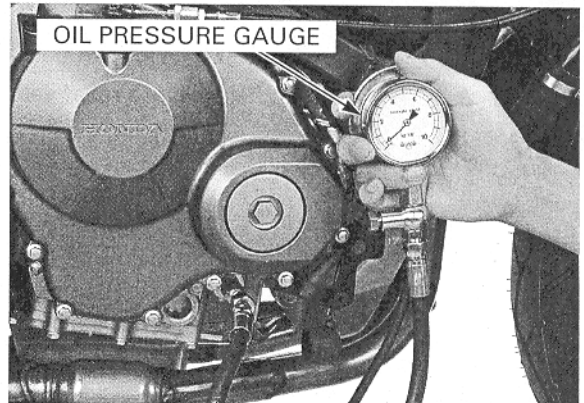
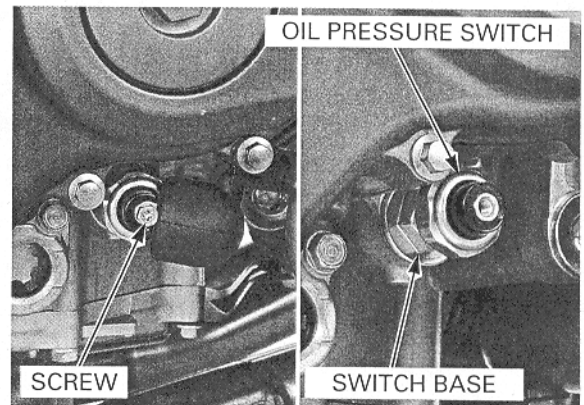

OIL STRAINER/PRESSURE RELIEF VALVE

REMOVAL

- Drain the engine oil (page 4-16).
- Remove the exhaust pipe (page 3-24).
- Remove the oil pan flange bolts, stay and oil pan.

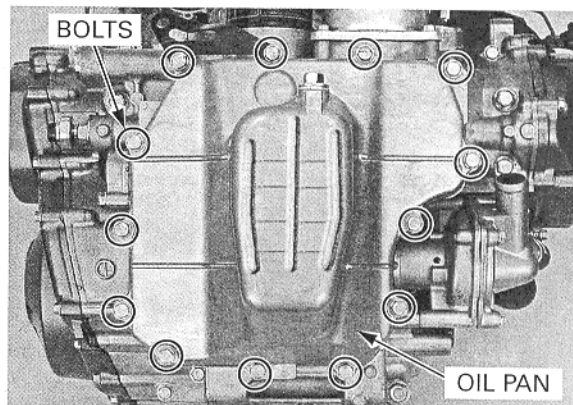

Remove the pressure relief valve and O-ring.

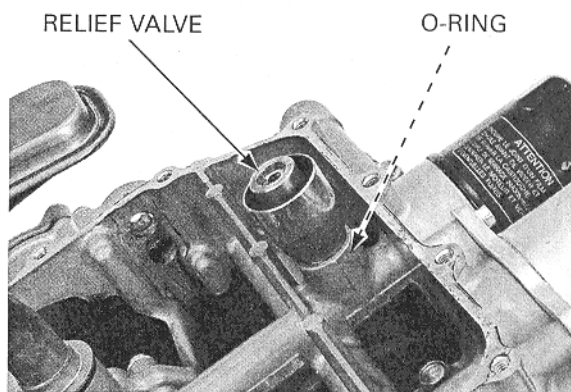

- Remove the oil strainer and oil seal.
- Clean the oil strainer screen.

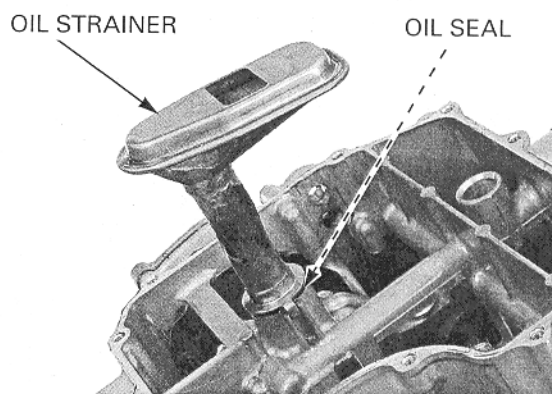

INSPECTION

- Check the operation of the pressure relief valve by pushing on the piston.
- Disassemble the relief valve by removing the snap ring.
- Inspect the piston for wear, unsmooth movement or damage.
- Inspect the spring for fatigue or damage.
- Assemble the relief valve in the reverse order of disassembly.

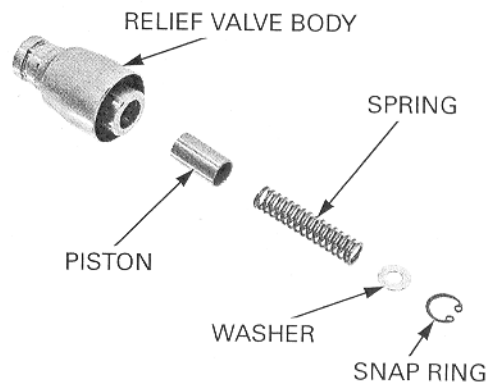

INSTALLATION

Apply oil to a new oil seal and install it onto the oil strainer.
Install the oil strainer into the crankcase while aligning the oil strainer boss with the groove of the crankcase.

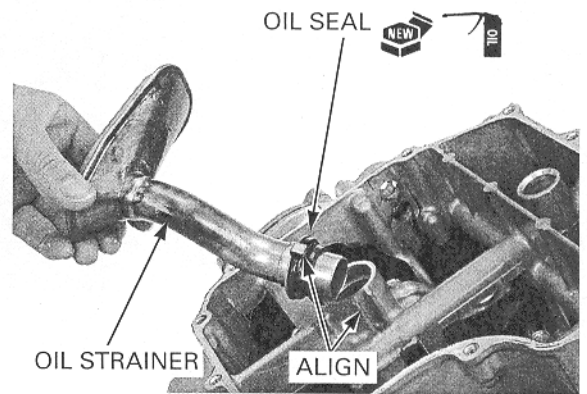

Apply oil to a new O-ring and install it onto the relief valve.
Install the relief valve into the crankcase.

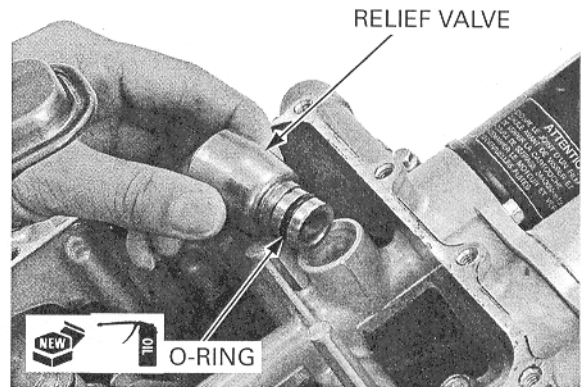

Clean the oil pan mating surface thoroughly.

Do not apply more sealant than necessary.

Apply sealant (Three Bond 1207B or an equivalent) to the mating surface.

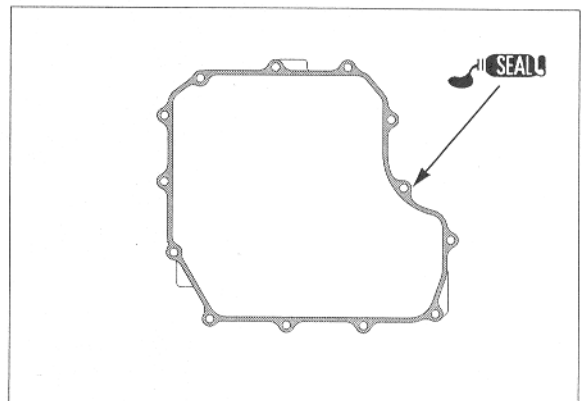

Install the oil pan onto the lower crankcase.
Install the oil pan flange bolts and stay.
Tighten the bolts in a crisscross pattern in two or three steps.

Install the exhaust pipe (page 3-26).
Fill the crankcase with the recommended oil (page 4-16).

After installation, check that there are no oil leaks.

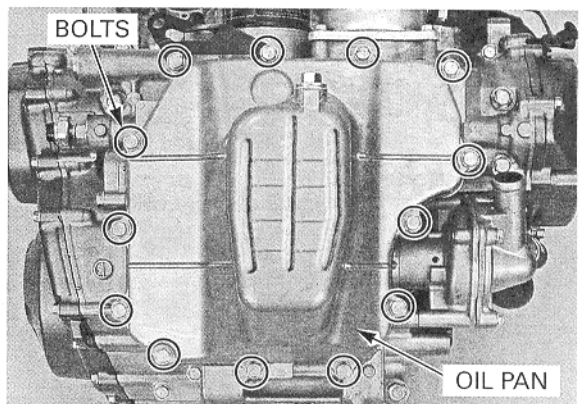

LUBRICATION SYSTEM

OIL PUMP

REMOVAL

Drain the engine oil (page 4-16).

Remove the right crankcase cover (page 10-5).

Remove the bolt, washer and oil pump driven sprocket.

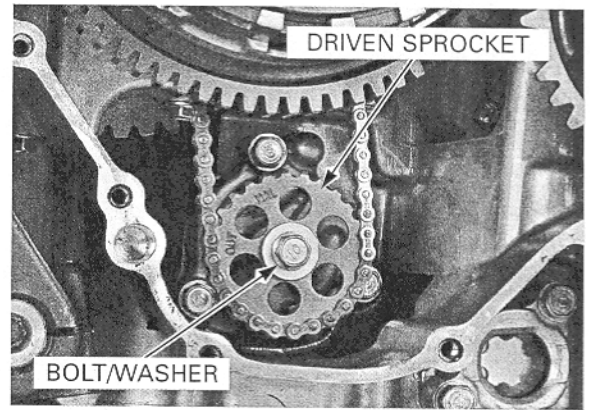

Remove the three flange bolts and oil pump assembly.

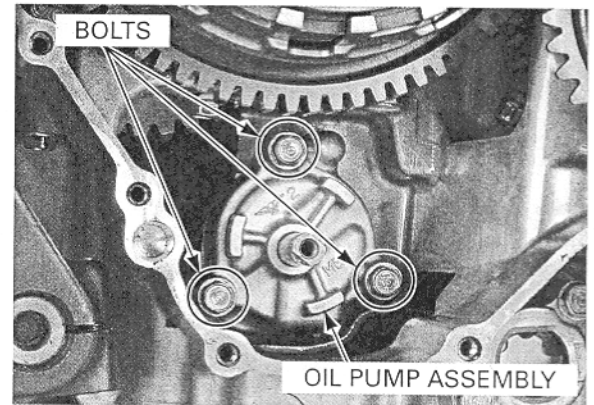

DISASSEMBLY

Remove the dowel pins.

Remove the oil pump assembly bolt and oil pump plate.

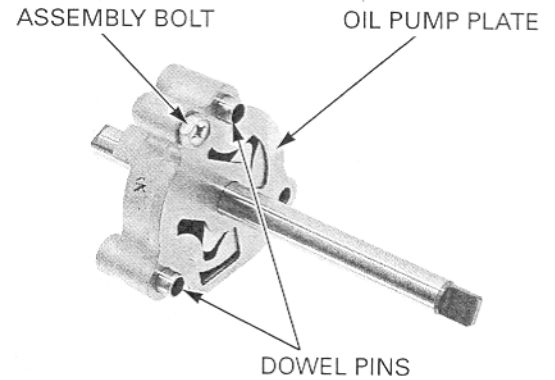

Remove the thrust washer, drive pin, oil pump shaft, outer rotor and inner rotor from the oil pump body.

Clean all disassembly parts thoroughly.

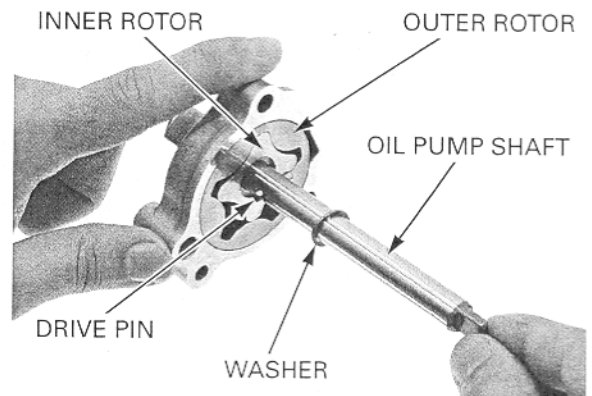

INSPECTION

If any portion of the oil pump is worn beyond the service limit, replace the oil pump as an assembly.

Temporarily install the outer and inner rotors into the oil pump body.
Temporarily install the drive pin and oil pump shaft.
Measure the rotor tip clearance.

SERVICE LIMIT: 0.20 mm (0.008 in)

TIP CLEARANCE:

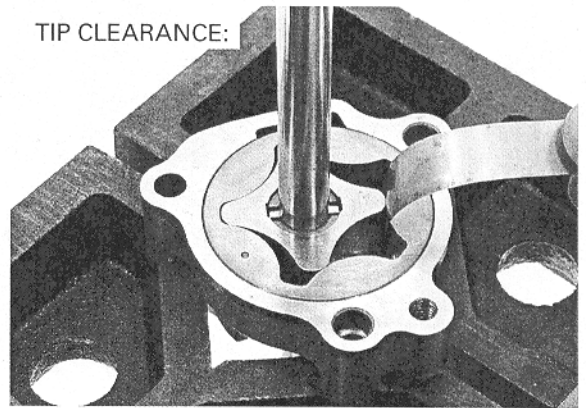

Measure the pump body clearance.

SERVICE LIMIT: 0.35 mm (0.014 in)

BODY CLEARANCE:

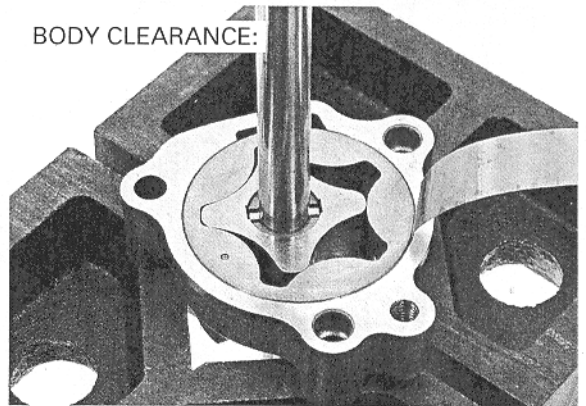

Measure the side clearance using a straight edge and feeler gauge.

SERVICE LIMIT: 0.17 mm (0.007 in)

SIDE CLEARANCE:

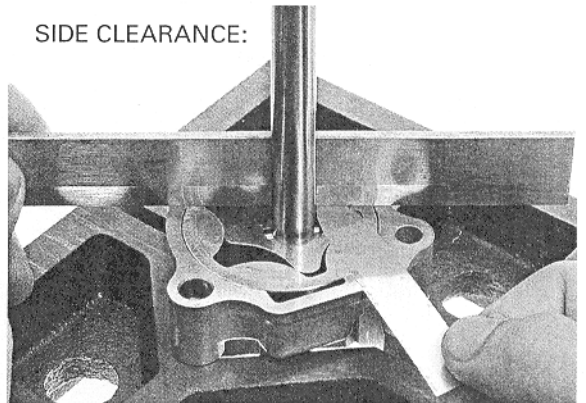

LUBRICATION SYSTEM

ASSEMBLY

Dip all parts in clean engine oil.

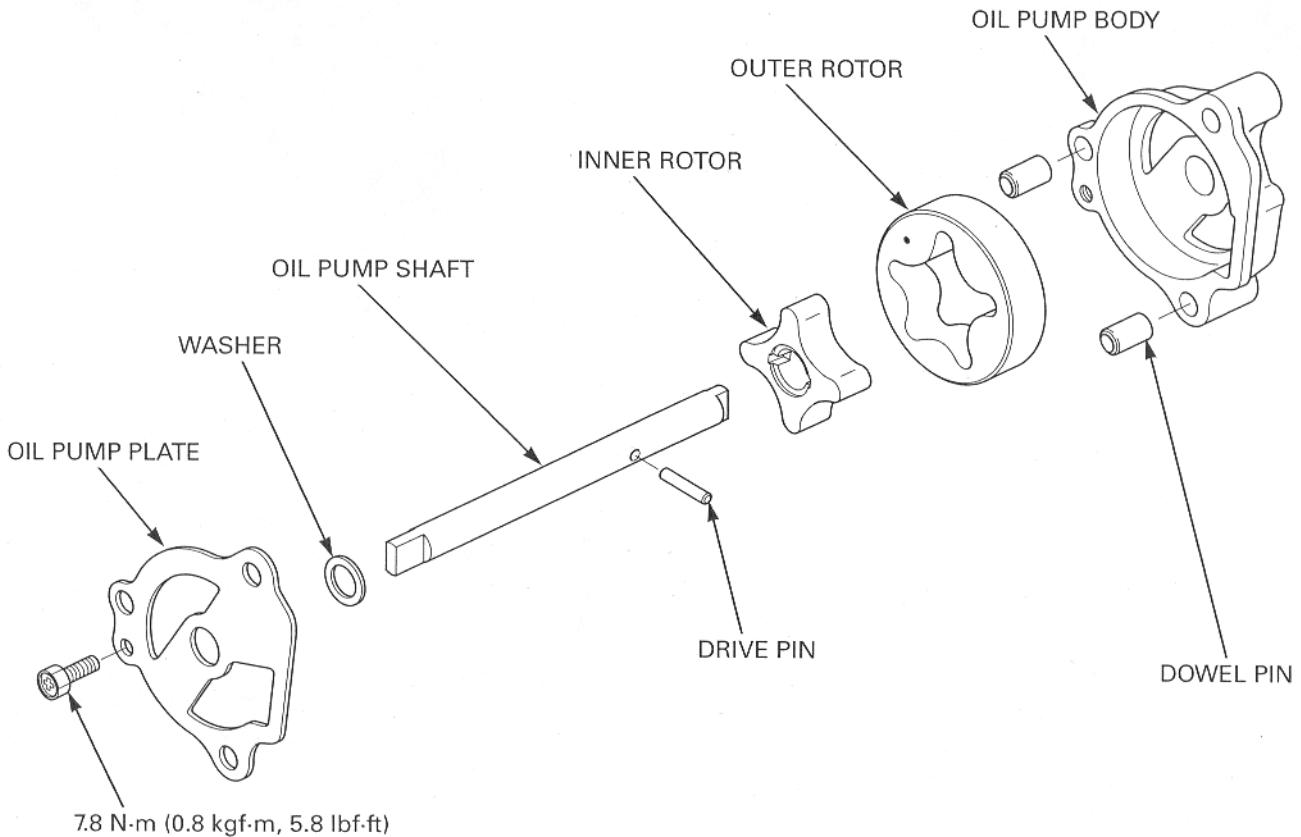

Install the outer rotor into the oil pump body with its punch mark facing the oil pump plate.
Install the inner rotor into the outer rotor with its drive pin groove facing the oil pump plate.
Install the oil pump shaft through the inner rotor and oil pump body.

Install the drive pin into the hole in the oil pump shaft and align the drive pin with the groove in the inner rotor.
Install the thrust washer.

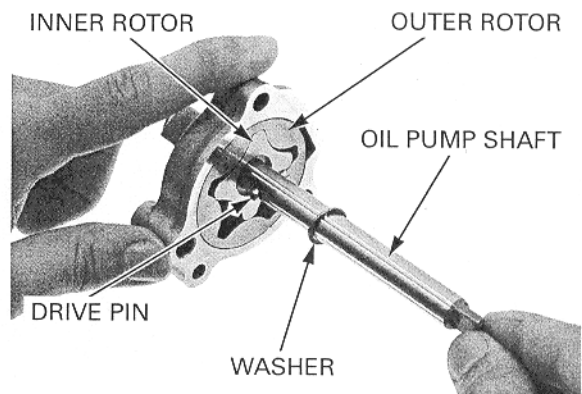

Install the dowel pins.
Install the oil pump plate and tighten the assembly bolt to the specified torque.

TORQUE: 7.8 N-m (0.8 kgf-m, 5.8 lbf-ft)

Check the oil pump operation by turning the pump shaft.
If necessary, reassemble the oil pump.

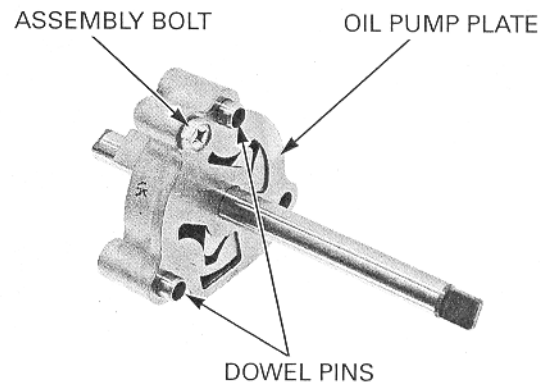

INSTALLATION

Install the oil pump assembly onto the crankcase while aligning the oil pump shaft lug with the water pump shaft groove by turning the oil pump shaft.

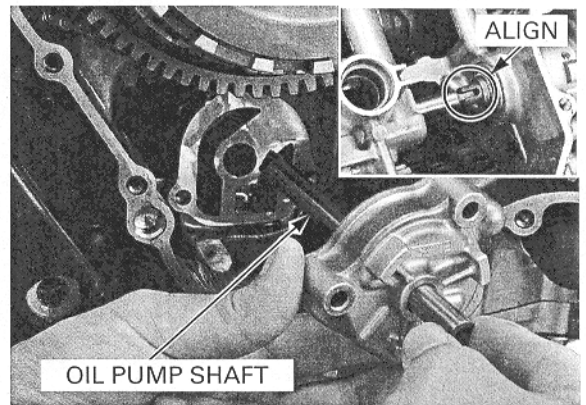

Install and tighten the three flange bolts securely.

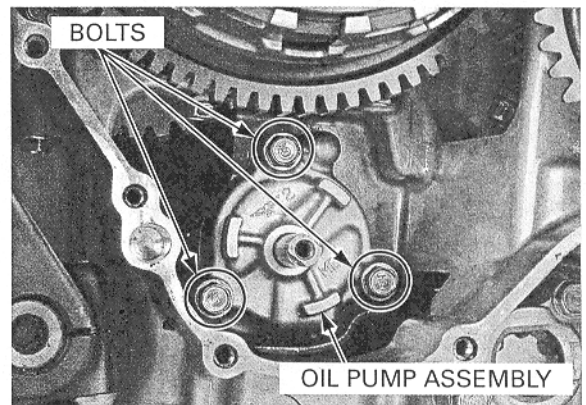

Apply oil to the oil pump driven sprocket and drive chain

Install the driven sprocket with its "OUT" mark facing out.

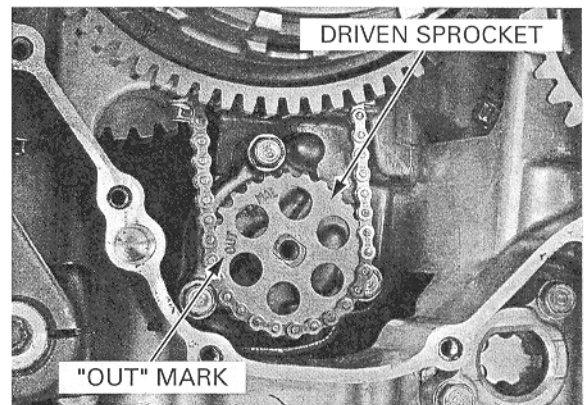

Apply a locking agent to the oil pump driven sprocket bolt threads.

Install and tighten the driven sprocket bolt/washer to the specified torque.

TORQUE: 15 N-m (1.5 kgf-m, 11 lbf-ft)

Install the right crankcase cover (page 10-24).

After installation, fill the crankcase with the recommended oil (page 4-16) and check that there is no oil leaks.

Check the oil pressure (page 5-5).

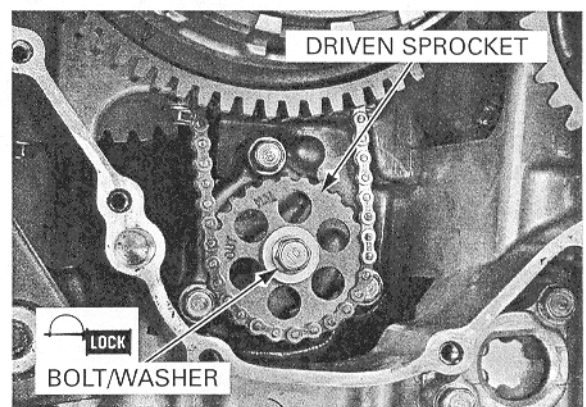

LUBRICATION SYSTEM

OIL COOLER

REMOVAL

Drain the engine oil (page 4-16).

Drain the coolant from the system (page 7-6).

Remove the exhaust pipe (page 3-24).

Loosen the hose clamp screws and disconnect the oil cooler water hoses from the oil cooler.

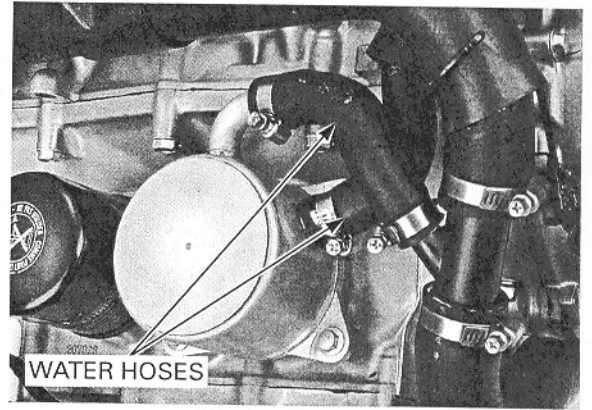

Remove the four bolts, washers and oil cooler. Remove the O-ring from the oil cooler.

INSPECTION

Check the oil cooler for damage.

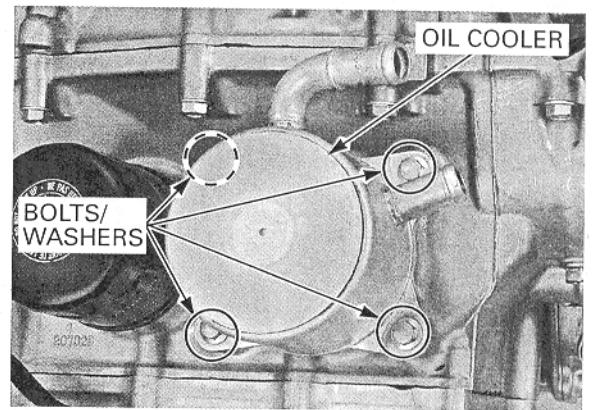

INSTALLATION

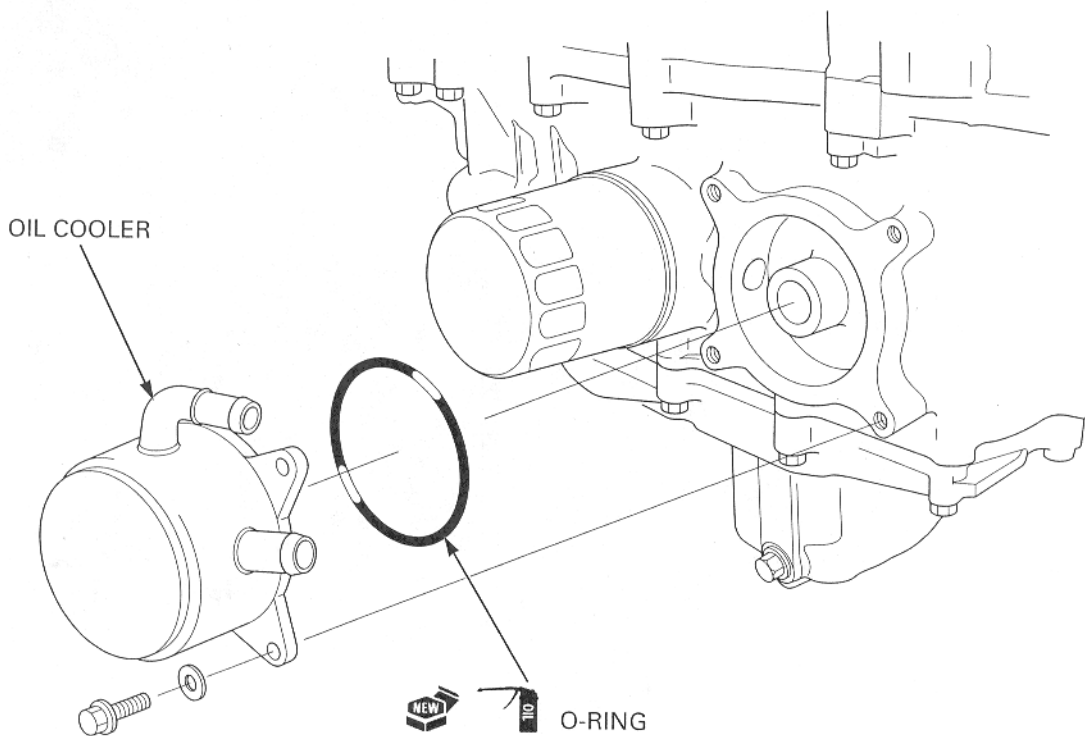

Coat a new O-ring with engine oil and install it into the oil cooler groove.

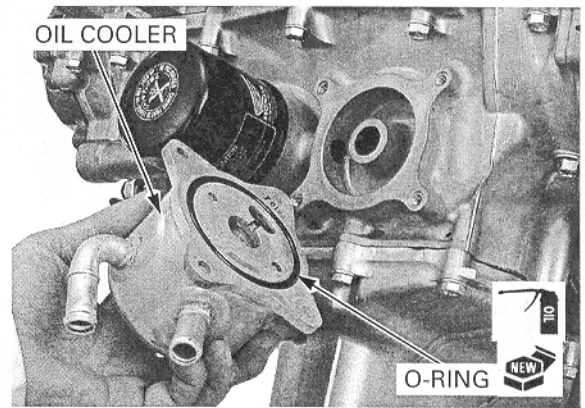

Install the oil cooler on the crankcase.
Install the four washers and bolts.
Tighten the bolts securely.

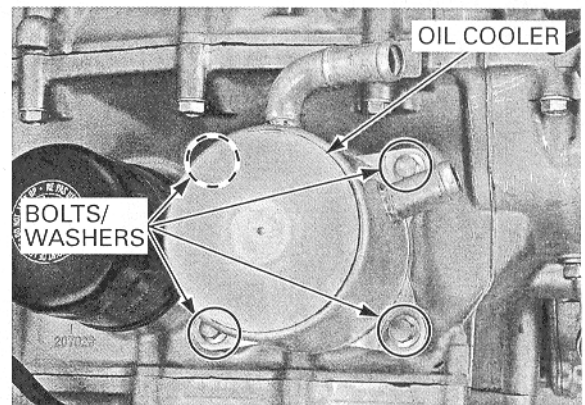

Connect the oil cooler water hoses into the oil cooler and tighten the hose clamp screws securely.
Install the exhaust pipe (page 3-26).
Fill the crankcase with the recommended oil (page 4-16) and check that there is no oil leaks.
Fill the cooling system and bleed any air (page 7-6).

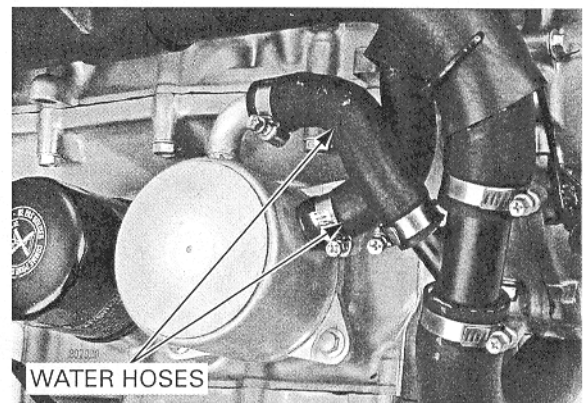

6. FUEL SYSTEM (Programmed Fuel Injection)

COMPONENT LOCATION.....	6-2	THROTTLE BODY	6-72
SERVICE INFORMATION	6-3	PRIMARY INJECTOR.....	6-79
TROUBLESHOOTING	6-5	FAST IDLE WAX UNIT	6-81
SYSTEM LOCATION.....	6-6	STARTER VALVE.....	6-82
SYSTEM DIAGRAM.....	6-7	STARTER VALVE SYNCHRONIZATION	6-86
PGM-FI SELF-DIAGNOSIS INFORMATION	6-8	MAP SENSOR.....	6-88
MIL CODE INDEX.....	6-12	IAT SENSOR	6-89
MIL TROUBLESHOOTING.....	6-15	ECT SENSOR	6-89
DTC CODE INDEX.....	6-33	CAM PULSE GENERATOR.....	6-90
DTC TROUBLESHOOTING.....	6-37	TP SENSOR.....	6-91
FUEL LINE INSPECTION	6-56	BANK ANGLE SENSOR	6-93
FUEL PUMP UNIT.....	6-58	ENGINE STOP RELAY	6-94
FUEL CUT-OFF RELAY	6-60	ENGINE CONTROL MODULE (ECM).....	6-94
FUEL TANK	6-61	PAIR CONTROL SOLENOID VALVE.....	6-96
AIR CLEANER HOUSING	6-64	EVAP PURGE CONTROL SOLENOID VALVE (California type only)	6-98
SECONDARY INJECTOR.....	6-67	O ₂ SENSOR (California type only)	6-99

FUEL SYSTEM (Programmed Fuel Injection)

COMPONENT LOCATION

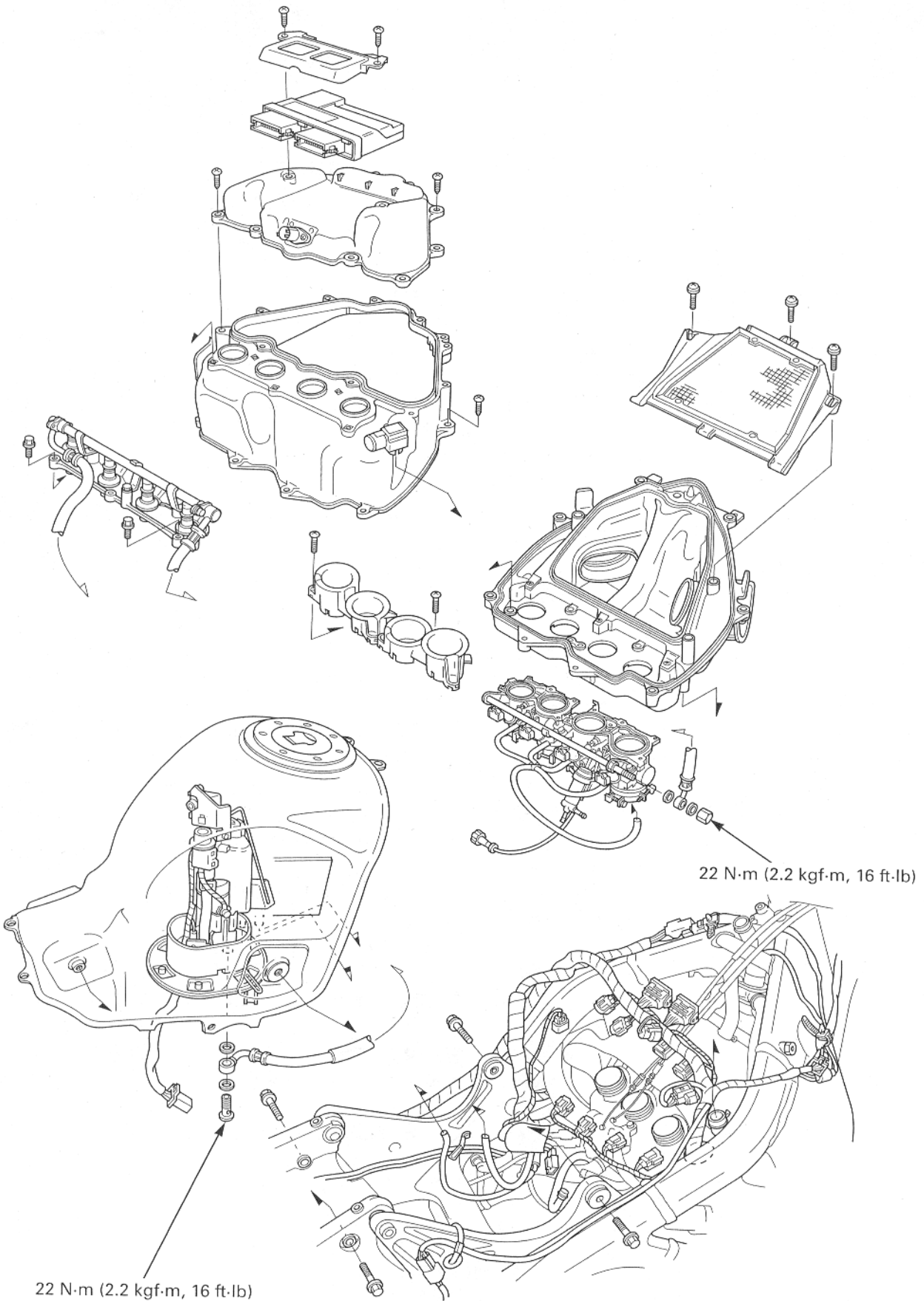

SERVICE INFORMATION

GENERAL

- Be sure to relieve the fuel pressure while the engine is OFF.
- Bending or twisting the control cables will impair smooth operation and could cause the cables to stick or bind, resulting in loss of vehicle control.
- Work in a well ventilated area. Smoking or allowing flames or sparks in the work area or where gasoline is stored can cause a fire or explosion.
- Do not apply commercially available carburetor cleaners to the inside of the throttle bore, which is coated with molybdenum.
- Do not snap the throttle valve from full open to full close after the throttle cable has been removed. It may cause incorrect idle operation.
- Seal the cylinder head intake ports with tape or a clean cloth to keep dirt and debris from entering the intake ports after the throttle body has been removed.
- Do not apply excessive force to the fuel pipe on the throttle body while removing or installing the throttle body.
- Do not damage the throttle body. It may cause incorrect throttle and idle valve synchronization.
- Prevent dirt and debris from entering the throttle bore, fuel tube and return tube, clean them using compressed air.
- The throttle body is factory pre-set. Do not disassemble in a way other than shown in this manual.
- Do not push the fuel pump base under the fuel tank when the fuel tank is stored.
- Always replace the packing when the fuel pump is removed.
- The programmed fuel injection (PGM-FI) system is equipped with the Self-Diagnostic System described (page 6-8). If the malfunction indicator lamp (MIL) blinks, follow the Self-Diagnostic Procedures to remedy the problem.
- When checking the PGM-FI, always follow the steps in the troubleshooting flow chart (page 6-15)(page 6-37).
- The PGM-FI system is provided with fail-safe function to secure a minimum running capability even when there is any trouble in the system. When any abnormality is detected by the self-diagnosis function, running capability is secured by using numerical values preset in advance in the program map. It must be remembered, however, that when any abnormality is detected in 8 injectors and/or the ignition and cam pulse generator, the fail safe function stops the engine to protect it from damage.
- Refer to PGM-FI system location (page 6-6).
- A faulty PGM-FI system is often related to poorly connected or corroded connectors. Check those connections before proceeding.
- Refer to procedures for fuel level sensor inspection (page 20-18).
- The vehicle speed sensor sends digital pulse signal to the ECM (PGM-FI unit) and computation. Refer to procedures for vehicle speed sensor inspection (page 20-13).
- When disassembling the programmed fuel injection parts, note the location of the O-rings. Replace them with new ones upon reassembly.
- Before disconnecting the fuel hose, release the fuel pressure by loosening the fuel hose banjo bolt at the fuel tank.
- Always replace the sealing washers when the fuel hose banjo bolt is removed or loosened.
- Use a digital tester for PGM-FI system inspection.

SPECIFICATIONS

ITEM		SPECIFICATIONS
Throttle body identification number	49 states, Canada type:	GQ63C
	California type:	GQ63B
Starter valve vacuum difference		20mm Hg
Base throttle valve for synchronization		No. 3
Idle speed		1,300 ± 100 rpm
Throttle grip free play		2 – 4 mm (1/16 – 1/8 in)
Intake air temperature sensor resistance (at 20°C/68°F)		1 – 4 kΩ
Engine coolant temperature sensor resistance (at 20°C/68°F)		2.3 – 2.6 kΩ
Fuel injection resistance (at 20°C /68°F)	Secondary injector	10.5 – 14.5 Ω
	Primary injector	10.5 – 14.5 Ω
PAIR control solenoid valve resistance (at 20°C/68°F)		20 – 24 Ω
Cam pulse generator peak voltage (at 20°C/68°F)		0.7 V minimum
Ignition pulse generator peak voltage (at 20°C/68°F)		0.7 V minimum
Manifold absolute pressure at idle		150 – 250 mm Hg
Fuel pressure at idle		343 kPa (3.5 kgf/cm ² , 50 psi)
Fuel pump flow (at 12V)		189 cm ³ (6.4 US oz, 6.7 Imp oz) minimum/10 seconds

FUEL SYSTEM (Programmed Fuel Injection)

TORQUE VALUES

ECT (Engine Coolant Temperature) sensor	23 N·m (2.3 kgf·m, 17 lbf·ft)
Throttle body insulator band screw	See page 1-15
Starter valve synchronization plate screw	0.9 N·m (0.09 kgf·m, 0.7 lbf·ft)
Starter valve lock nut	1.8 N·m (0.18 kgf·m, 1.3 lbf·ft)
Fast idle wax unit link plate screw	0.9 N·m (0.09 kgf·m, 0.7 lbf·ft)
Fast idle wax unit mounting screw	4.9 N·m (0.5 kgf·m, 3.6 lbf·ft)
Fuel filler cap socket bolt	1.8 N·m (0.18 kgf·m, 1.3 lbf·ft)
Secondary injector bracket mounting bolt	5.4 N·m (0.55 kgf·m, 4 lbf·ft)
Fuel rail mounting bolt	9.8 N·m (1.0 kgf·m, 7 lbf·ft)
Fuel feed hose banjo bolt (fuel tank side)	22 N·m (2.2 kgf·m, 16 lbf·ft)
Fuel hose sealing nut (throttle body side)	22 N·m (2.2 kgf·m, 16 lbf·ft)
Fuel pump mounting nut	12 N·m (1.2 kgf·m, 9 lbf·ft)
O ₂ sensor (California type only)	25 N·m (2.6 kgf·m, 19 lbf·ft)

See page 1-16 for tightening sequence

TOOLS

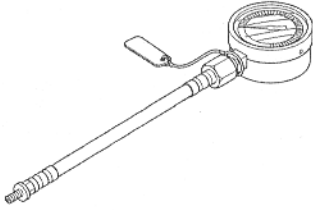
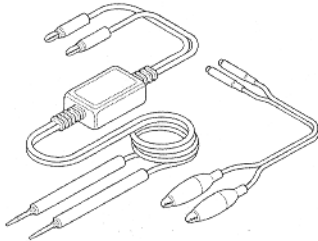
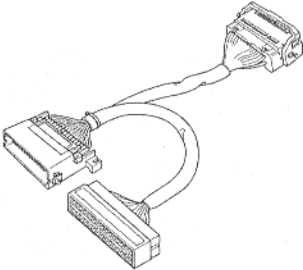
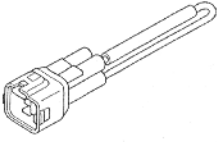
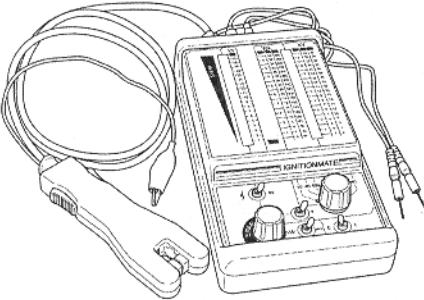
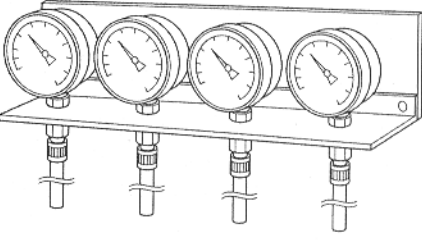
<p>Fuel pressure gauge, 100 psi 07406-0040003</p>  <p>or 07406-0040002 or 07406-004000A (U.S.A. only)</p>	<p>Peak voltage adaptor 07HGJ-0020100 (not available in U.S.A.)</p>  <p>with commercially available digital multimeter (impedance 10 MΩ/DCV minimum)</p>	<p>ECM test harness 070MZ-0010200</p>  <p>(two required)</p>
<p>SCS service connector 070PZ-ZY30100</p> 	<p>Ignition Mate peak voltage tester MTP07-0286 (U.S.A. only)</p> 	<p>Vacuum gauge set 07LMJ-001000A</p> 

TROUBLESHOOTING

Engine won't start

- Intake air leak
- Fuel contaminated/deteriorated
- Pinched or clogged fuel hose
- Faulty fuel pump unit
- Clogged fuel filter/strainer
- Clogged fuel injector filter
- Sticking fuel injector needle
- Faulty fuel pump operating system

Engine stalls, hard to start, rough idling

- Intake air leak
- Fuel contaminated/deteriorated
- Pinched or clogged fuel hose
- Idle speed misadjusted
- Starter valve synchronization misadjusted

Backfiring or misfiring during acceleration

- Ignition system malfunction

Poor performance (drive ability) and poor fuel economy

- Pinched or clogged fuel hose
- Faulty pressure regulator

FUEL SYSTEM (Programmed Fuel Injection)

SYSTEM LOCATION

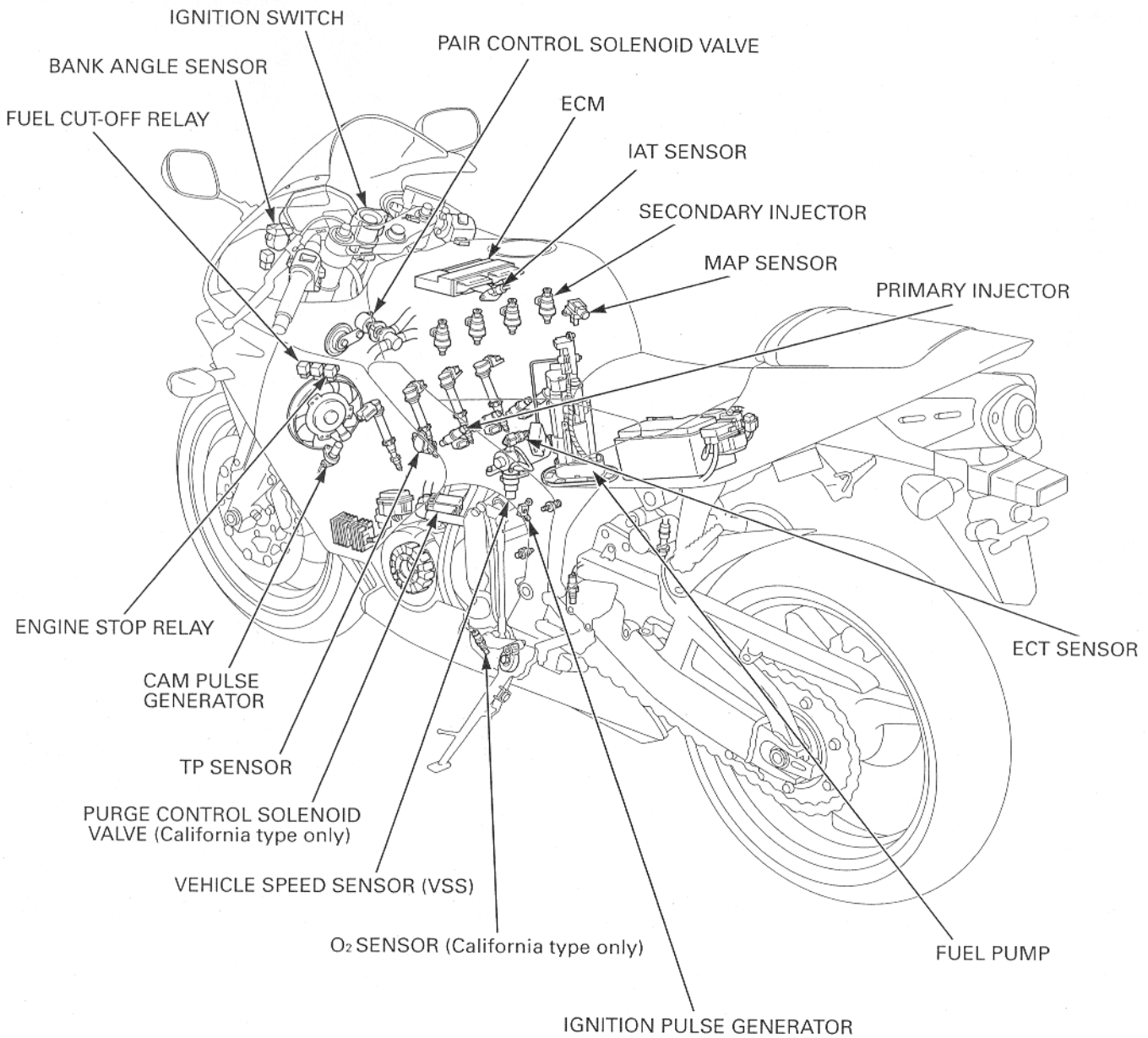

FULL NAME	ABBREVIATIONS
Manifold absolute pressure sensor	MAP sensor
Throttle position sensor	TP sensor
Intake air temperature sensor	IAT sensor
Engine coolant temperature sensor	ECT sensor
Engine control module	ECM

SYSTEM DIAGRAM

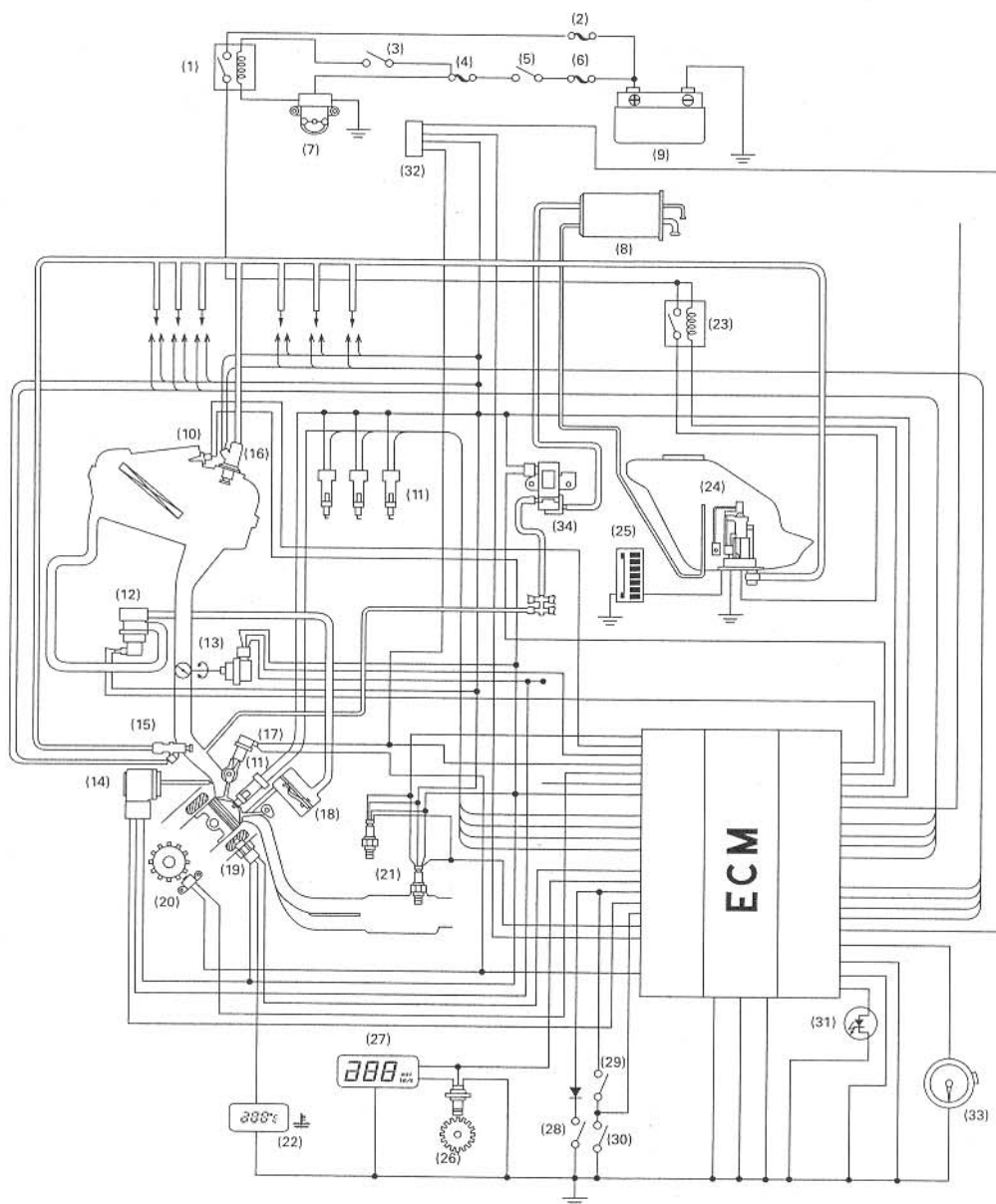

- | | |
|--------------------------------------|---|
| (1) Engine stop relay | (19) ECT sensor |
| (2) PGM-FI fuse (20A) | (20) Ignition pulse generator |
| (3) Engine stop switch | (21) O ₂ sensor (California type only) |
| (4) Sub-fuse (10A) | (22) Water temperature LCD |
| (5) Ignition switch | (23) Fuel cut-off relay |
| (6) Main fuse A (30A) | (24) Fuel pump unit |
| (7) Bank angle sensor | (25) Fuel indicator |
| (8) EVAP canister (California type) | (26) Vehicle speed sensor |
| (9) Battery | (27) Speedometer |
| (10) IAT sensor | (28) Neutral switch |
| (11) Direct ignition coil/spark plug | (29) Clutch switch |
| (12) PAIR control solenoid valve | (30) Side stand switch |
| (13) TP sensor | (31) Malfunction indicator lamp (MIL) |
| (14) MAP sensor | (32) Data link connector |
| (15) Primary injector | (33) Tachometer |
| (16) Secondary injector | (34) EVAP purge control solenoid valve (California type only) |
| (17) Cam pulse generator | |
| (18) PAIR check valve | |

FUEL SYSTEM (Programmed Fuel Injection)

PGM-FI SELF-DIAGNOSIS INFORMATION

SELF-DIAGNOSTIC PROCEDURE

Place the motorcycle on its side stand.

Start the engine and let it idle.

NOTE:

If the engine will not start, turn the starter motor for more than 10 seconds and check that the MIL blinks.

If the malfunction indicator lamp (MIL) does not light or blink, the system has no memory of problem data.

If the malfunction indicator blinks, note how many times the MIL blinks or read the Diagnosis Trouble Code (DTC) with the Honda Diagnosis System (HDS) Pocket Tester, and determine the cause of the problem (page 6-12, page 6-37).

If you wish to read the PGM-FI memory for trouble data, perform the following:

The MIL will blink only with the side stand down and with the engine off (engine stop switch is RUN) or engine revs are below 5,000 rpm. In any other condition, the MIL will illuminate and stay on.

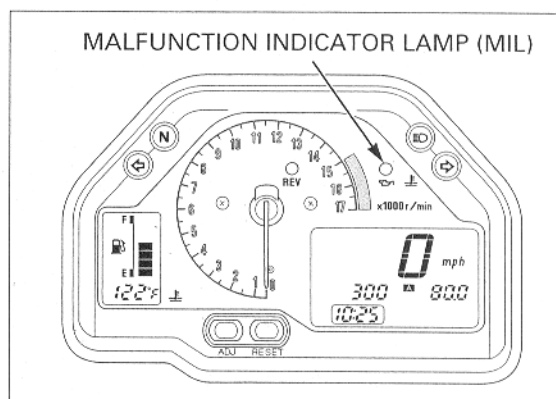

DTC (With the HDS Pocket Tester)

Turn the ignition switch OFF.

Remove the seat (page 3-4).

Connect the HDS Pocket Tester to the Data Link Connector (DLC).

Turn the ignition switch ON and engine stop switch "Q".

Check the Diagnostic Trouble Code (DTC) and note it. Also check the freeze data.

Refer to the DTC index (page 6-33) and begin the appropriate troubleshooting procedure.

NOTE:

For specific operations, refer to the user's manual that came with the HDS Pocket Tester.

MIL CODE (Without the HDS Pocket Tester)

Turn the ignition switch OFF.

Remove the seat (page 3-4).

Short the Data Link Connector (DLC) terminals using the special tool.

TOOL:

SCS service connector 070PZ-ZY30100

Turn the ignition switch ON and engine stop switch "Q".

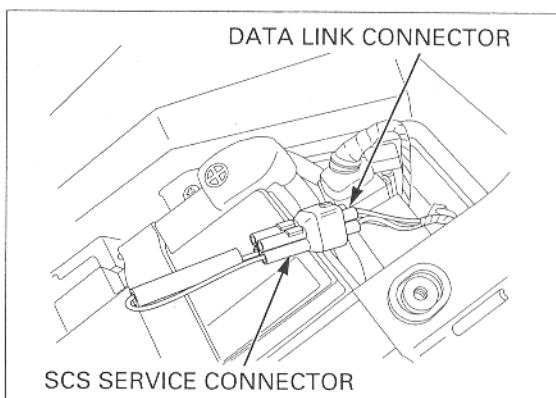
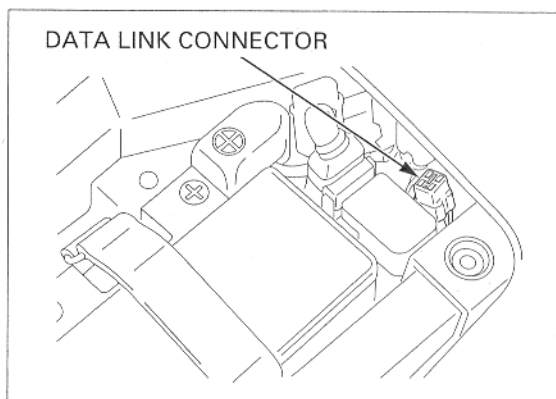

FUEL SYSTEM (Programmed Fuel Injection)

Even if the PGM-FI has memory data, the MIL does not blink when the engine is running.

If the ECM has no self diagnosis memory data, the MIL will illuminate, when you turn the ignition switch ON.

If the ECM has self diagnosis memory data, the MIL will start blinking when you turn the ignition switch ON.

Note how many times the MIL blinks, and determine the cause of the problem (page 6-12).

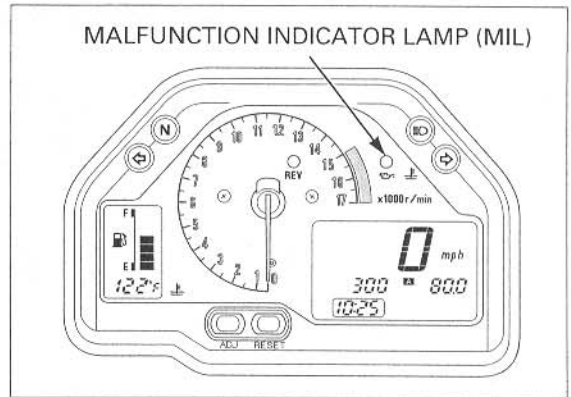

SELF-DIAGNOSIS RESET PROCEDURE

Reset the self-diagnosis memory data in either of 2 ways;

With the HDS

Use the HDS Pocket Tester to clear the ECU memory. See the HDS Pocket Tester user's manual for specific instruction.

Without the HDS

1. Turn the engine stop switch "O" and ignition switch OFF.
2. Short the Data Link Connector (DLC) terminals using a special tool.

TOOL:

SCS service connector **070PZ-ZY30100**

3. Turn the ignition switch ON.
4. Remove the special tool from the Data Link Connector (DLC).

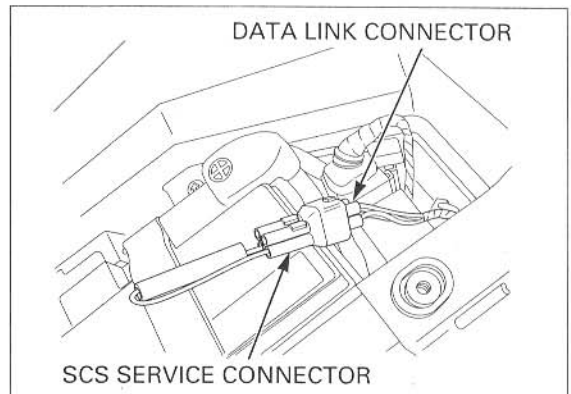

5. The MIL lights about 5 seconds. While the indicator lights, short the Data Link Connector (DLC) again with the special tool.

Self-diagnosis memory data is erased, if the MIL turns off and starts blinking.

- The Data Link Connector (DLC) must be jumped while the indicator is lit. If not, the MIL will not start blinking.
- Note that the self diagnosis memory data cannot be erased if you turn off the ignition switch before the MIL starts blinking.

If the MIL blinks 20 times, the data has not been erased, so try again.

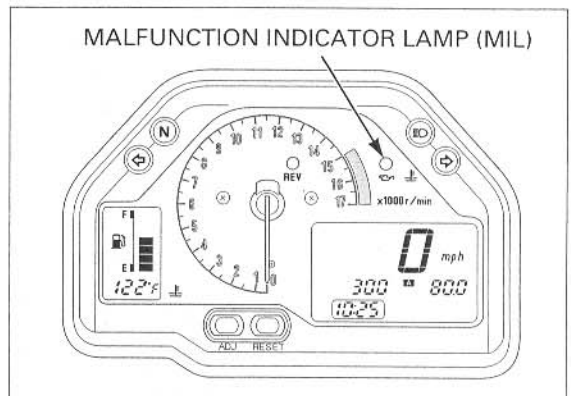

FUEL SYSTEM (Programmed Fuel Injection)

PEAK VOLTAGE INSPECTION PROCEDURE

- Use this procedure for the ignition pulse generator and cam pulse generator inspection.
- Check all system connections before inspection. If the system is disconnected, incorrect peak voltage might be measured.
- Check cylinder compression and check that all spark plugs are installed correctly.
- Use the recommended digital multimeter or commercially available digital multimeter with an impedance of 10 M Ω /DCV minimum.
- If the Imrie diagnostic tester (model 625) is used, follow the manufacturer's instruction.
- The display value differs depending upon the internal impedance of the multimeter.
- Disconnect the fuel pump connector before checking the peak voltage.

Lift and support the fuel tank (page 6-61).

Disconnect the fuel pump unit 3P (Black) connector.

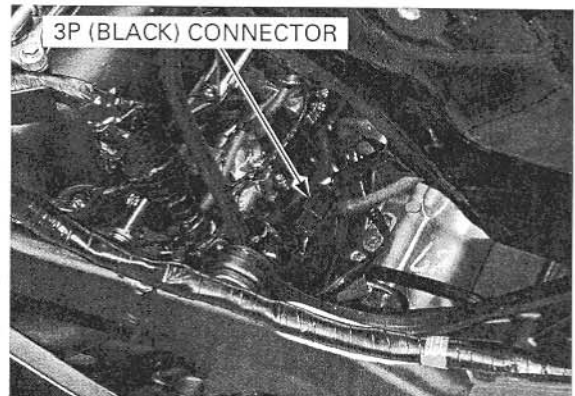

Avoid touching the tester probes to prevent electric shock.

Connect the peak voltage adaptor to the digital multimeter.

TOOLS:

IgnitionMate peak voltage tester MTP07-0286
(U.S.A. only) or
07HGJ-0020100
(not available in
U.S.A.)

Peak voltage adaptor

with commercially available digital multimeter
(impedance 10 M Ω /DCV minimum)

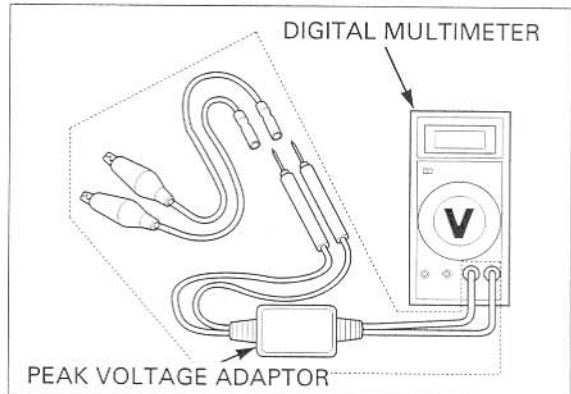

TEST HARNESS CONNECTION

Remove the following:

- Fuel tank cover (page 3-15)
- ECM cover (page 6-94)

Disconnect the ECM 32P (Black) and 32P (Light gray) connectors from the ECM.

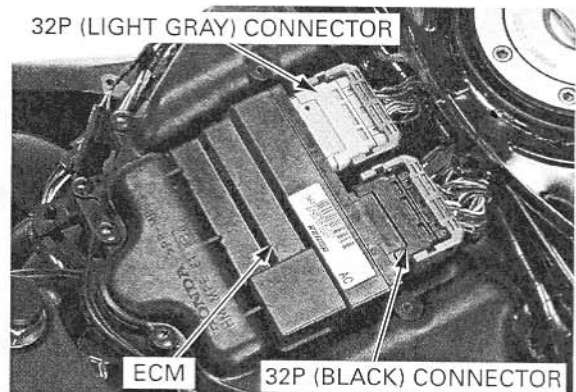

FUEL SYSTEM (Programmed Fuel Injection)

Connect the ECM test harnesses between the main wire harness and the ECM.

TOOLS:

ECM test harness

070MZ-0010200
(two required)

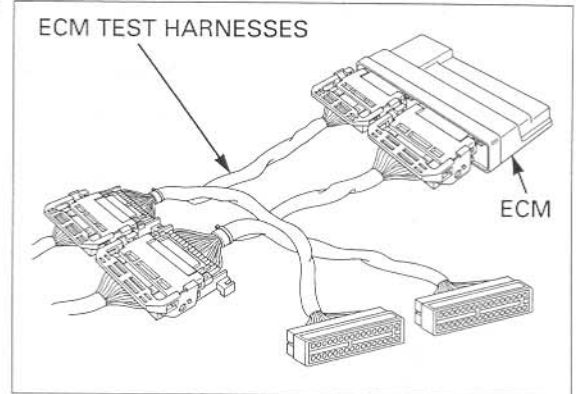

TEST HARNESS TERMINAL LAYOUT

The ECM connector terminals are numbered as shown.

VIEW FROM WIRE HARNESS SIDE:

A: 32P (BLACK) CONNECTOR

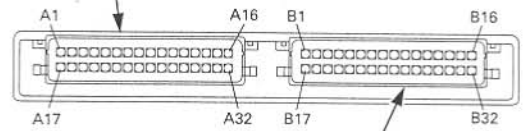

B: 32P (LIGHT GRAY) CONNECTOR

The ECM test harness terminals are same layout as for the ECM connector terminals as shown.

FOR 32P (BLACK) CONNECTOR

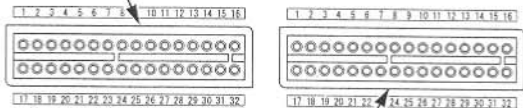

FOR 32P (LIGHT GRAY) CONNECTOR

FUEL SYSTEM (Programmed Fuel Injection)

MIL CODE INDEX

- The PGM-FI MIL denotes the failure codes (the number of blinks from 0 to 49). When the indicator lights for 1.3 seconds, it is equivalent to ten blinks. For example, a 1.3 second illumination and two blinks (0.5 second x 2) of the indicator equals 12 blinks. Follow code 12 troubleshooting (page 6-24).
- When more than one failure occurs, the MIL shows the blinks in the order of lowest number to highest number. For example if the indicator blinks once, then two times, two failures have occurred. Follow codes 1 (page 6-15) and 2 (page 6-16) troubleshooting.

MIL	Function Failure	Causes	Symptoms	Refer to
No blinks	ECM malfunction	<ul style="list-style-type: none"> • Faulty ECM 	<ul style="list-style-type: none"> • Engine does not start 	6-94
No blinks	ECM power/ground circuits malfunction	<ul style="list-style-type: none"> • Open circuit at the power input wire of the ECM • Faulty bank angle sensor • Open circuit in bank angle sensor related circuit • Faulty engine stop relay • Open circuit in engine stop relay related wires • Faulty engine stop switch • Open circuit in engine stop switch related wires • Faulty ignition switch • Blown PGM-FI fuse (20 A) • Blown sub-fuse (10A) (Starter, Bank angle sensor) 	<ul style="list-style-type: none"> • Engine does not start 	6-94
No blinks	ECM output line malfunction	<ul style="list-style-type: none"> • ECM output voltage line (Yellow/red wire) short circuit 	<ul style="list-style-type: none"> • Engine does not start 	–
No blinks	MIL circuit malfunction	<ul style="list-style-type: none"> • Faulty ECM • Open or short circuit in MIL wire 	<ul style="list-style-type: none"> • Engine operates normally 	6-8
Stays lit	Data link circuit malfunction	<ul style="list-style-type: none"> • Short circuit in data link connector • Faulty ECM • Short circuit in data link connector wire 	<ul style="list-style-type: none"> • Engine operates normally 	–
1 Blink	MAP sensor circuit malfunction	<ul style="list-style-type: none"> • Loose or poor contact on MAP sensor connector • Open or short circuit in MAP sensor wire • Faulty MAP sensor 	<ul style="list-style-type: none"> • Engine operates normally 	6-15
2 Blinks	MAP sensor performance problem	<ul style="list-style-type: none"> • Loose or poor connection of the MAP sensor vacuum hose • Faulty MAP sensor 	<ul style="list-style-type: none"> • Engine operates normally 	6-16
7 Blinks	ECT sensor circuit malfunction	<ul style="list-style-type: none"> • Loose or poor contact on ECT sensor • Open or short circuit in ECT sensor wire • Faulty ECT sensor 	<ul style="list-style-type: none"> • Hard start at a low temperature (Simulate using numerical values; 90 °C/ 194 °F) 	6-17
8 Blinks	TP sensor circuit malfunction	<ul style="list-style-type: none"> • Loose or poor contact on TP sensor connector • Open or short circuit in TP sensor wire • Faulty TP sensor 	<ul style="list-style-type: none"> • Poor engine performance response and when operating the throttle quickly (Simulate using numerical values; Throttle opens 0°) 	6-19
9 Blinks	IAT sensor circuit malfunction	<ul style="list-style-type: none"> • Loose or poor contact on IAT sensor • Open or short circuit in IAT sensor wire • Faulty IAT sensor 	<ul style="list-style-type: none"> • Engine operates normally (Simulate using numerical values; 25 °C/ 77 °F) 	6-21
11 Blinks	Vehicle speed sensor circuit malfunction	<ul style="list-style-type: none"> • Loose or poor contact on vehicle speed sensor connector • Open or short circuit in vehicle speed sensor wire • Faulty vehicle speed sensor 	<ul style="list-style-type: none"> • Engine operates normally 	6-22

FUEL SYSTEM (Programmed Fuel Injection)

MIL	Function Failure	Causes	Symptoms	Refer to
12 Blinks	No.1 Primary injector circuit malfunction	<ul style="list-style-type: none"> • Loose or poor contact on No.1 Primary injector connector • Open or short circuit in No.1 Primary injector wire • Faulty No.1 Primary injector 	<ul style="list-style-type: none"> • Engine does not start 	6-24
13 Blinks	No.2 Primary injector circuit malfunction	<ul style="list-style-type: none"> • Loose or poor contact on No.2 Primary injector connector • Open or short circuit in No.2 Primary injector wire • Faulty No.2 Primary injector 	<ul style="list-style-type: none"> • Engine does not start 	6-25
14 Blinks	No.3 Primary injector circuit malfunction	<ul style="list-style-type: none"> • Loose or poor contact on No.3 Primary injector connector • Open or short circuit in No.3 Primary injector wire • Faulty No.3 Primary injector 	<ul style="list-style-type: none"> • Engine does not start 	6-25
15 Blinks	No.4 Primary injector circuit malfunction	<ul style="list-style-type: none"> • Loose or poor contact on No.4 Primary injector connector • Open or short circuit in No.4 Primary injector wire • Faulty No.4 Primary injector 	<ul style="list-style-type: none"> • Engine does not start 	6-25
16 Blinks	No.1 Secondary injector circuit malfunction	<ul style="list-style-type: none"> • Loose or poor contact on No.1 Secondary injector connector • Open or short circuit in No.1 Secondary injector wire • Faulty No.1 Secondary injector 	<ul style="list-style-type: none"> • Engine does not start 	6-25
17 Blinks	No.2 Secondary injector circuit malfunction	<ul style="list-style-type: none"> • Loose or poor contact on No.2 Secondary injector connector • Open or short circuit in No.2 Secondary injector wire • Faulty No.2 Secondary injector 	<ul style="list-style-type: none"> • Engine does not start 	6-25
18 Blinks	Cam pulse generator, no signal	<ul style="list-style-type: none"> • Loose or poor contact on cam pulse generator • Open or short circuit in cam pulse generator • Faulty cam pulse generator 	<ul style="list-style-type: none"> • Engine does not start 	6-26
19 Blinks	Ignition pulse generator, no signal	<ul style="list-style-type: none"> • Loose or poor contact on ignition pulse generator • Open or short circuit in ignition pulse generator • Faulty ignition pulse generator 	<ul style="list-style-type: none"> • Engine does not start 	6-27
21 Blinks	No.1 O ₂ sensor circuit malfunction (California type only)	<ul style="list-style-type: none"> • Loose or poor contact on O₂ sensor connector • Short circuit in O₂ sensor • Faulty O₂ sensor 	<ul style="list-style-type: none"> • Engine operates normally 	6-28
22 Blinks	No.2 O ₂ sensor circuit malfunction (California type only)	<ul style="list-style-type: none"> • Loose or poor contact on O₂ sensor connector • Short circuit in O₂ sensor • Faulty O₂ sensor 	<ul style="list-style-type: none"> • Engine operates normally 	6-29
23 Blinks	No.1 O ₂ sensor heater malfunction (California type only)	<ul style="list-style-type: none"> • Loose or poor contact on O₂ sensor connector • Open or short circuit in O₂ sensor heater • Faulty O₂ sensor 	<ul style="list-style-type: none"> • Engine operates normally 	6-30
24 Blinks	No.2 O ₂ sensor heater malfunction (California type only)	<ul style="list-style-type: none"> • Loose or poor contact on O₂ sensor connector • Open or short circuit in O₂ sensor heater • Faulty O₂ sensor 	<ul style="list-style-type: none"> • Engine operates normally 	6-31

FUEL SYSTEM (Programmed Fuel Injection)

MIL	Function Failure	Causes	Symptoms	Refer to
33 Blinks	E ² -PROM in ECM malfunction	<ul style="list-style-type: none"> Faulty ECM 	<ul style="list-style-type: none"> Engine operates normally Does not hold the self-diagnosis data 	6-32
48 Blinks	No.3 Secondary injector circuit malfunction	<ul style="list-style-type: none"> Loose or poor contact on No.3 Secondary injector connector Open or short circuit in No.3 Secondary injector wire Faulty No.3 Secondary injector 	<ul style="list-style-type: none"> Engine does not start 	6-25
49 Blinks	No.4 Secondary injector circuit malfunction	<ul style="list-style-type: none"> Loose or poor contact on No.4 Secondary injector connector Open or short circuit in No.4 Secondary injector wire Faulty No.4 Secondary injector 	<ul style="list-style-type: none"> Engine does not start 	6-25

MIL TROUBLESHOOTING

MIL 1 BLINK (MAP SENSOR)

- Before starting the inspection, check for loose or poor contact on the MAP sensor connector and recheck the MIL blinking.

1. MAP Sensor Output Voltage Inspection

Turn the ignition switch OFF.
Connect the ECM test harness to ECM connectors (page 6-10).

Turn the ignition switch ON and engine stop switch "Q".

Measure the voltage at the test harness terminals.

Is the voltage within 2.7 – 3.1V?

- YES** –
- Intermittent failure
 - Loose or poor contact on the ECM connectors
- NO** –
- About 5 V
GO TO STEP 2.
 - About 0 V
GO TO STEP 3.

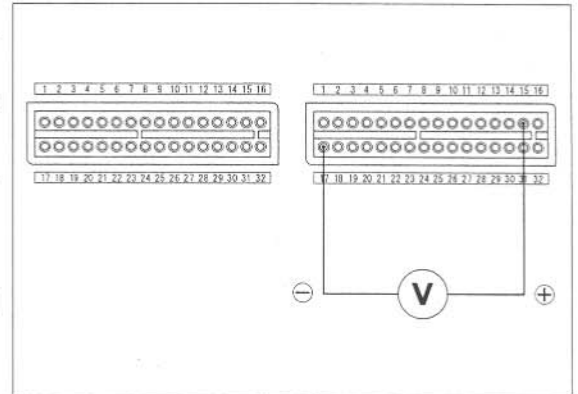

2. MAP Sensor Output Line Inspection

Turn the ignition switch OFF.
Disconnect the MAP sensor 3P connector.

Turn the ignition switch ON and engine stop switch "Q".

Measure the voltage at the wire harness side.

Connection: Light green/yellow (+) – Green/orange (-)

Is the voltage within 4.75 – 5.25V?

- YES** – Faulty MAP sensor
- NO** –
- Open circuit in Light green/yellow wire
 - Open circuit in Green/orange wire

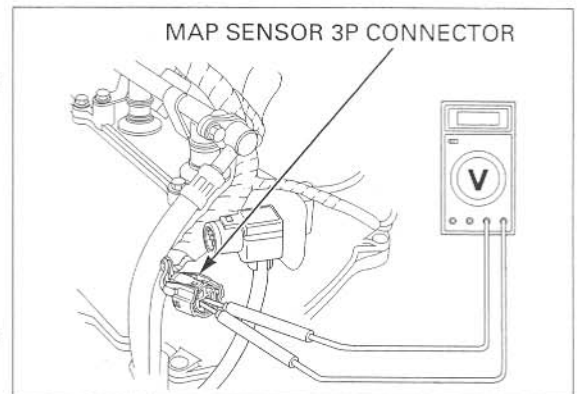

3. MAP Sensor Input Voltage Inspection

Measure the voltage at the wire harness side.

Connection: Yellow/red (+) – Ground (-)

Is the voltage within 4.75 – 5.25V?

- YES** – GO TO STEP 4.
- NO** – GO TO STEP 5.

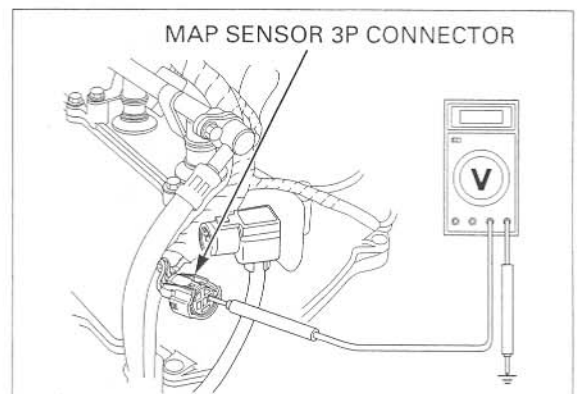

FUEL SYSTEM (Programmed Fuel Injection)

4. MAP Sensor Output Line Short Circuit Inspection

Check for continuity between the MAP sensor 3P connector terminal of the wire harness side and ground.

Connection: Light green/yellow – Ground

Is there continuity?

YES – Short circuit in Light green/yellow/yellow wire

NO – Faulty MAP sensor

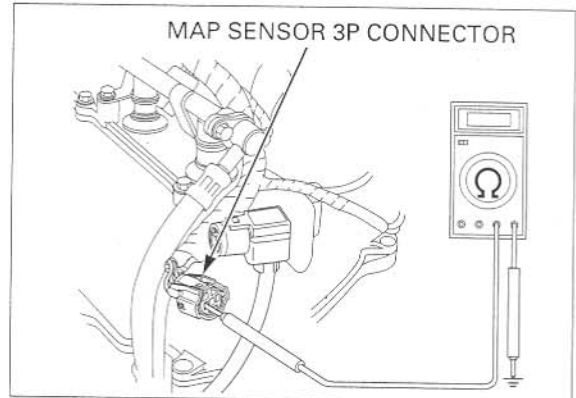

5. MAP Sensor Input Line Inspection

Turn the ignition switch OFF.
Disconnect the ECM 32P connectors.

Check for continuity at the Yellow/red wire between the MAP sensor 3P connector terminal and the ECM 32P (Light gray) connector.

Connection: B18 – Yellow/red

Is there continuity?

YES – Replace the ECM with a known good one, and recheck.

NO – Open circuit in Yellow/red wire

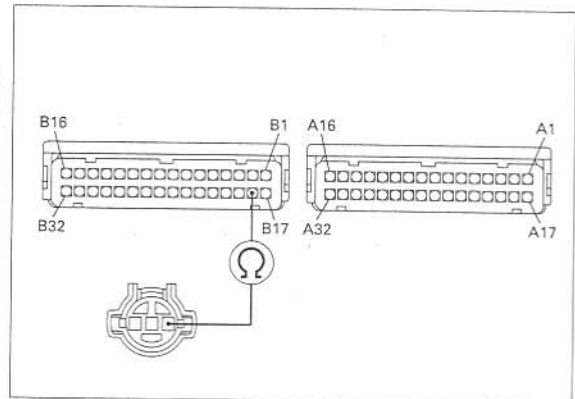

MIL 2 BLINKS (MAP SENSOR)

- Before starting the inspection, check for loose or poor contact on the MAP sensor connector and recheck the MIL blinking.

1. MAP Sensor Hose Inspection

Turn the ignition switch OFF

Check for connection and installation of the MAP sensor vacuum hose.

Is the MAP sensor hose connection correct?

YES – GO TO STEP 2.

NO – Correct the hose connection or installation

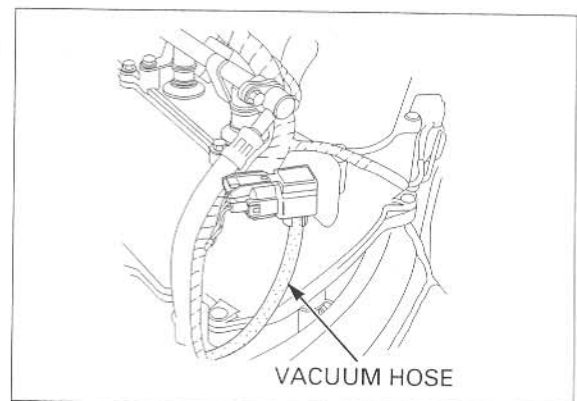

FUEL SYSTEM (Programmed Fuel Injection)

2. MAP Sensor Output Voltage Inspection

Connect the ECM test harness to ECM connectors (page 6-10).

Turn the ignition switch ON and engine stop switch " Ω ".

Measure the voltage at the test harness terminals.

Connection: B15 (+) –B17 (-)

Is the voltage within 2.7 – 3.1 V?

YES – GO TO STEP 3.

NO – Faulty MAP sensor

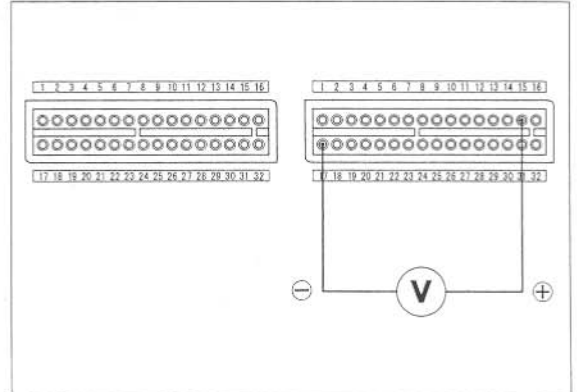

3. MAP Sensor Output Voltage Inspection At Idle

Start the engine.

Measure the voltage at the test harness terminals.

Connection: B15 (+) –B17 (-)

Standard: 2.7 V maximum

Is the voltage less than 2.7 V?

YES – Replace the ECM with a known good one, and recheck

NO – Faulty MAP sensor

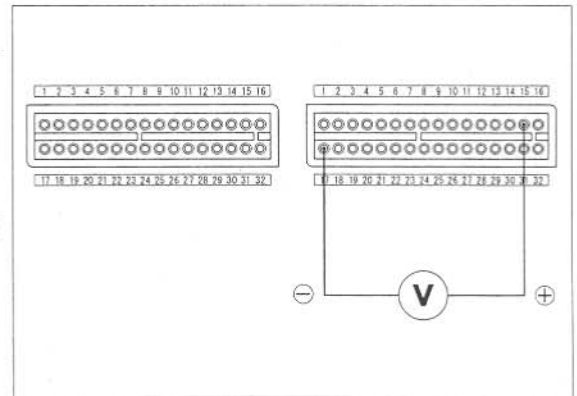

MIL 7 BLINKS (ECT SENSOR)

- Before starting the inspection, check for loose or poor contact on the ECT sensor connector and recheck the MIL blinking.

1. ECT Sensor Output Voltage Inspection

Turn the ignition switch OFF.

Connect ECM the test harness to ECM connectors (page 6-10).

Turn the ignition switch ON and engine stop switch " Ω ".

Measure the voltage at the ECM test harness terminals.

Connection: B27 (+) –B17 (-)

Standard: 2.7 – 3.1 V (20°C/68°F)

Is the voltage within 2.7 – 3.1 V?

YES – • Intermittent failure
• Loose or poor contact on the ECM connectors

NO – GO TO STEP 2.

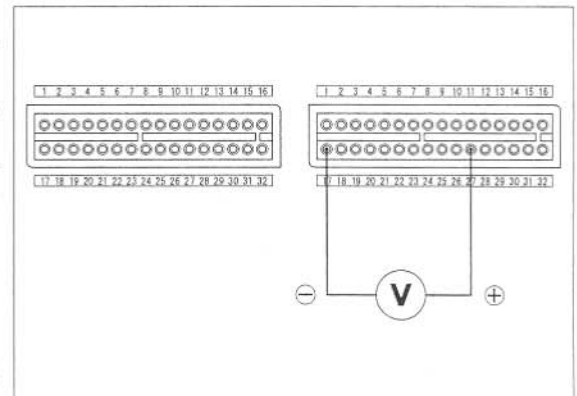

FUEL SYSTEM (Programmed Fuel Injection)

2. ECT Sensor Input Voltage Inspection

Turn the ignition switch OFF.
Disconnect the ECT sensor 3P connector.
Turn the ignition switch ON and engine stop switch " Ω ".
Measure the voltage at the wire harness side of ECT sensor connector.

Connection: Pink (+) – Ground (-)

Is the voltage within 4.75 – 5.25V?

YES – Inspect the ECT sensor (page 20-16)

NO – GO TO STEP 3.

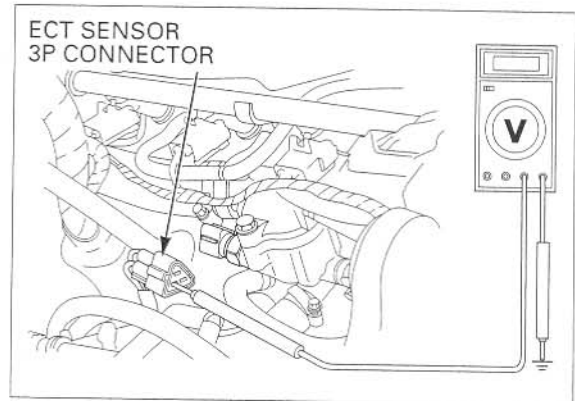

3. ECT Sensor Resistance Inspection

Turn the ignition switch OFF.
Disconnect the ECT sensor connector.
Measure the resistance at the ECT sensor terminals.

Connection: Pink (+) – Green/orange (-) (sensor side terminals)

Standard: 2.3 – 2.6 Ω (20 °C/68 °F)

Is the resistance within 2.3 – 2.6 Ω 20 °C/68 °F?

NO – Faulty ECT sensor.

YES – GO TO STEP 4.

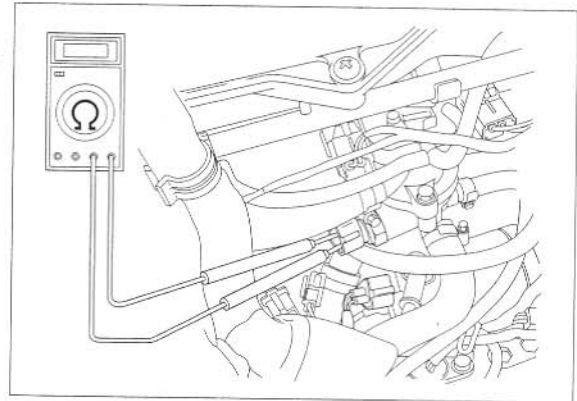

4. ECT Sensor Open Circuit Inspection

Turn the ignition switch OFF.
Check for continuity at the Pink and Green/orange wires between the ECT sensor 3P connector terminal and the ECM 32P (Light gray) connector terminal.

**Connection: B17 – Pink
B27 – Green/orange**

Is there continuity?

YES – GO TO STEP 5.

NO – • Open circuit in Pink or Pink/white wire
• Open circuit in Green/orange wire

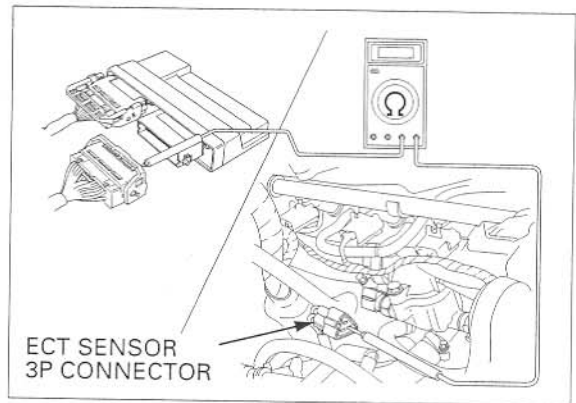

5. ECT Sensor Output Line Short Circuit Inspection

Check for continuity between the ECT sensor 3P connector terminal of the wire harness side and ground.

Connection: Pink – Ground

Is there continuity?

YES – Short circuit in Pink wire

NO – Replace the ECM with a known good one, and recheck.

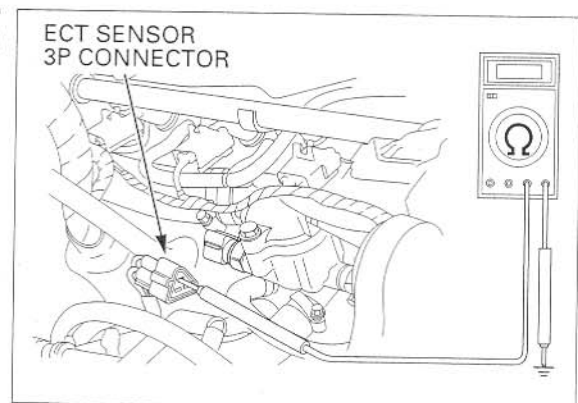

MIL 8 BLINKS (TP SENSOR)

- Before starting the inspection, check for loose or poor contact on the TP sensor connector and recheck the MIL blinking.

1. TP Sensor Output Voltage Inspection

Turn the ignition switch OFF.

Connect the ECM test harness to ECM connectors (page 6-10).

Turn the ignition switch ON and engine stop switch "Q".

Measure the TP sensor output voltage at the test harness terminals.

Connection: B14 (+) – B17 (-)

Standard: *0.4 – 0.6 V (throttle fully closed)

*4.2 – 4.8 V (throttle fully opened)

NOTE:

- A voltage marked * refers to the value of the ECM output voltage (STEP 1) when the voltage reading shows 5 V.

When the ECM output voltage reading shows other than 5 V, derive the TP sensor output voltage at the test harness as follows:

In the case of the ECM output voltage is 4.75 V:

V:

$$0.4 \times 4.75 / 5.0 = 0.38 \text{ V}$$

$$0.6 \times 4.75 / 5.0 = 0.57 \text{ V}$$

Thus, the solution is "0.38 – 0.57 V" with the throttle fully closed.

Replace 0.4 and 0.6 with 4.2 and 4.8 respectively, in the above equations to determine the throttle fully opened range.

Is there standard voltage?

- YES** –
- Intermittent failure
 - Loose or poor contact on the ECM connectors

NO – GO TO STEP 2.

2. TP Sensor Input Voltage Inspection

Turn the ignition switch OFF.

Disconnect the TP sensor 3P connector.

Turn the ignition switch ON and engine stop switch "Q".

Measure the voltage at the wire harness side.

Connection: Yellow/red (+) – Green/orange (-)

Is the voltage within 4.75 – 5.25 V?

YES – GO TO STEP 4.

NO – GO TO STEP 3.

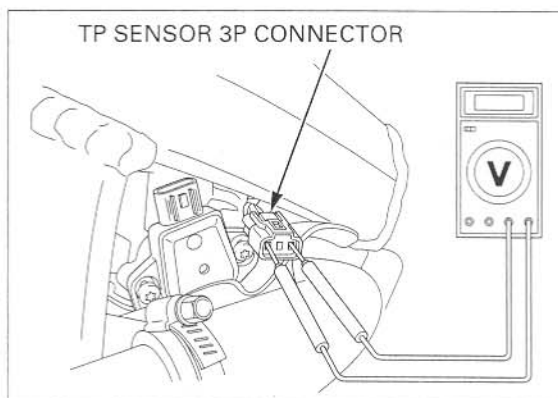
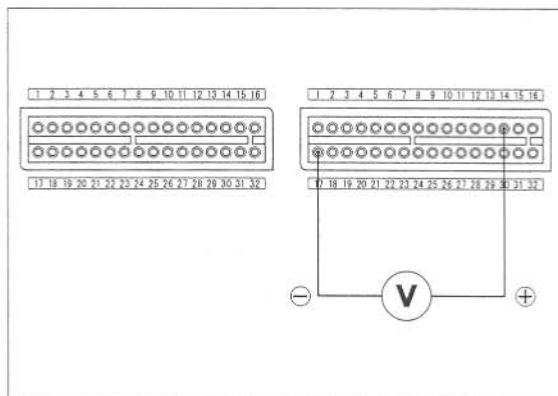

FUEL SYSTEM (Programmed Fuel Injection)

3. ECM Output Voltage Inspection

Turn the ignition switch OFF.
Connect the ECM test harness to ECM connectors (page 6-10).

Turn the ignition switch ON and engine stop switch " \odot ".
Measure the voltage at the test harness terminals.

Connection: B18 (+) -B17 (-)

Is the voltage within 4.75 - 5.25V?

- YES** - • Open circuit in Yellow/red wire
• Open circuit in Green/orange wire
- NO** - Replace the ECM with a known good one, and recheck.

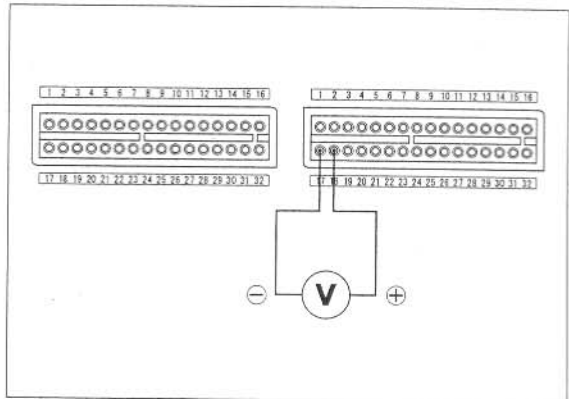

4. TP Sensor Output Line Inspection

Check for continuity between the TP sensor 3P connector terminal of the wire harness side and ECM 32P (Light gray) connector.

Connection: Red/yellow - B14

Is there continuity?

- YES** - GO TO STEP 5.
- NO** - Open circuit in Red/yellow wire

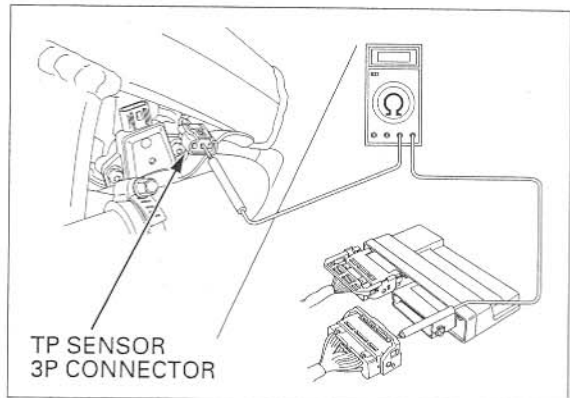

5. TP Sensor Output Line Short Circuit Inspection

Turn the ignition switch OFF.

Check for continuity between the TP sensor 3P connector terminal of the wire harness side and ground.

Connection: Red/yellow (+) - Ground (-)

Is there continuity?

- YES** - Short circuit in Red/yellow wire
- NO** - Faulty TP sensor

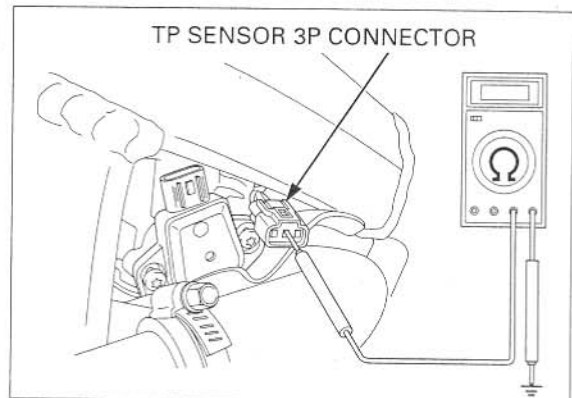

MIL 9 BLINKS (IAT SENSOR)

- Before starting the inspection, check for loose or poor contact on the IAT sensor connector and recheck the MIL blinking.

1. IAT Sensor Output Voltage Inspection

Turn the ignition switch OFF.
Connect the ECM test harness to ECM connectors (page 6-10).

Turn the ignition switch ON and engine stop switch "Q".
Measure the voltage at the test harness terminals.

Connection: B30 (+) -B17 (-)
Standard: 2.7 – 3.1 V (20°C/68°F)

Is the voltage within 2.7 – 3.1 V?

- YES** –
- Intermittent failure
 - Loose or poor contact on the ECM connectors

NO – GO TO STEP 2.

2. IAT Sensor Input Voltage Inspection

Turn the ignition switch OFF.
Disconnect the IAT sensor 2P connector.

Turn the ignition switch ON and engine stop switch "Q".
Measure the voltage at the wire harness side of IAT sensor connector.

Connection: Gray/blue – Green/orange

Is the voltage within 4.75 – 5.25V?

YES – GO TO STEP 3.

NO – GO TO STEP 4.

3. IAT Sensor Resistance Inspection

Turn the ignition switch OFF.
Disconnect the IAT sensor 2P connector.
Measure the resistance at the IAT sensor terminals (at 20 – 30 °C/68 – 86 °F).

Standard: 1 – 4 kΩ (20 – 30 °C/68 – 86 °F)

Is the resistance within 1 – 4 kΩ?

NO – Faulty IAT sensor

YES – GO TO STEP 4.

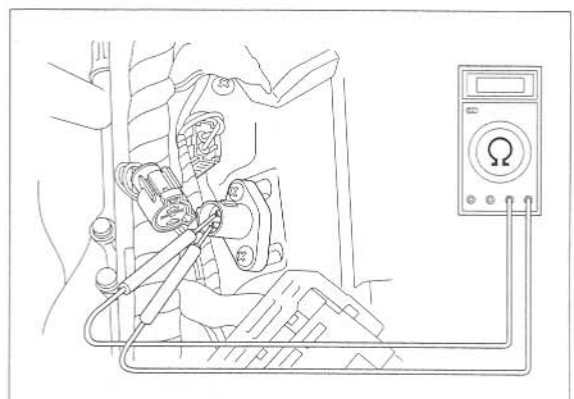
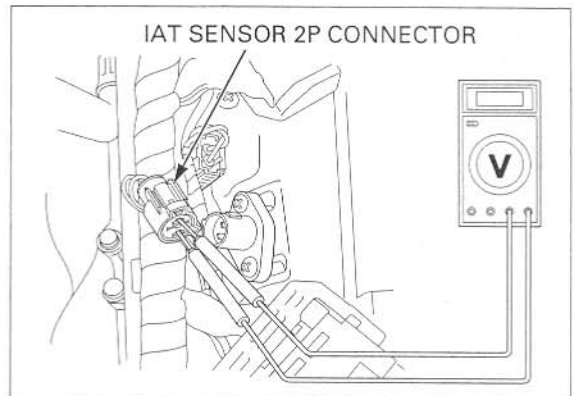
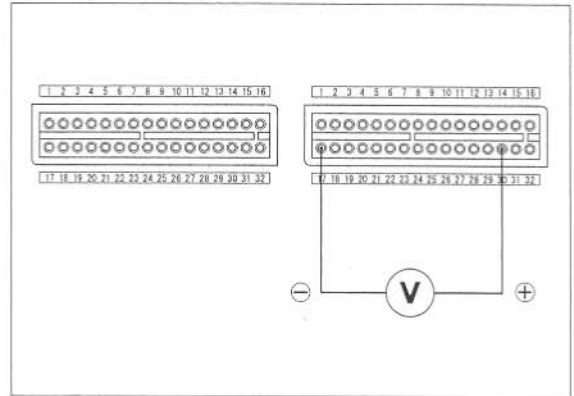

FUEL SYSTEM (Programmed Fuel Injection)

4. IAT Sensor Open Circuit Inspection

Turn the ignition switch OFF.
Check for continuity at the Gray/blue and Green/orange wires between the IAT sensor 2P connector terminal and the ECM 32P (Light gray) connector.

Are there continuity?

YES – GO TO STEP 5.

NO – • Open circuit in Gray/blue wire
• Open circuit in Green/orange wire

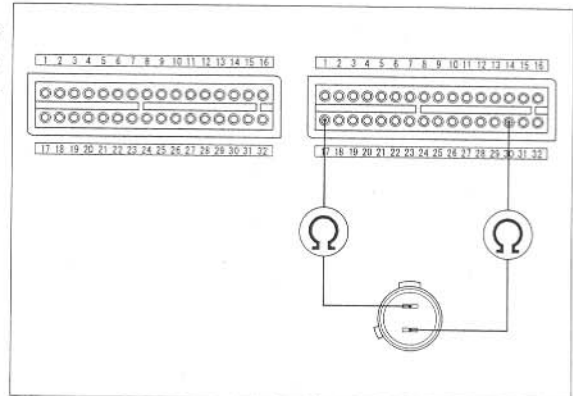

5. IAT Sensor Output Line Short Circuit Inspection

Check for continuity between the IAT sensor 2P connector terminal of the wire harness side and ground.

Connection: Gray/blue – Ground

Is there continuity?

YES – Short circuit in Gray/blue wire

NO – Replace the ECM with a known good one and recheck.

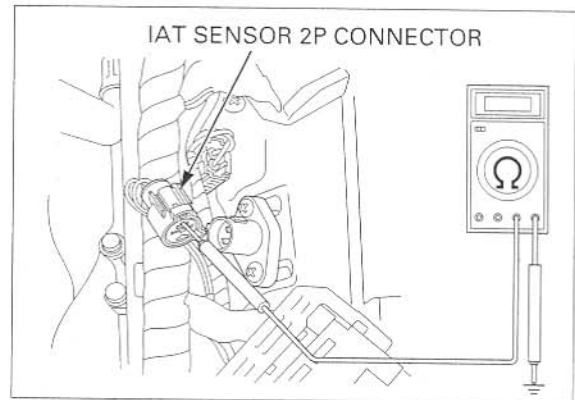

MIL 11 BLINKS (VEHICLE SPEED SENSOR)

- Before starting the inspection, check for loose or poor contact on the vehicle speed sensor connector and recheck the MIL blinking.

1. Vehicle Speed Sensor Pulse Inspection

Turn the ignition switch OFF.
Connect the ECM test harness to the ECM connectors (page 6-10).

Support the motorcycle securely and place the rear wheel off the ground.

Shift the transmission into gear.

Measure the voltage at the test harness terminals with the ignition switch ON and engine stop switch "Q" while slowly turning the rear wheel by hand.

Connection: B25 (+) – A4 (-)

Standard: Repeat 0 to 5 V

Is there standard voltage?

YES – • Intermittent failure
• Loose or poor contact on the ECM connectors

NO – GO TO STEP 2.

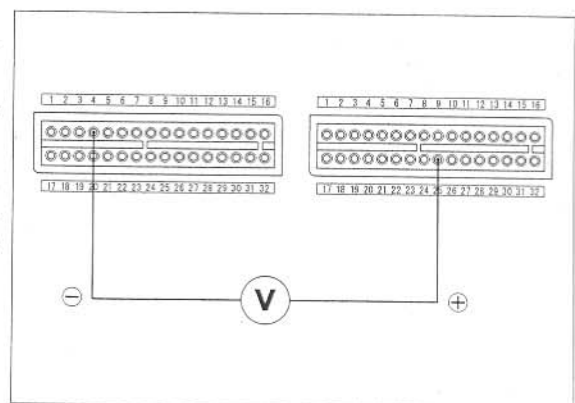

FUEL SYSTEM (Programmed Fuel Injection)

2. Combination Meter Inspection

Check for operation of speed meter.

Does the speed meter operate normally?

YES – Open or short circuit in the Pink/green wire

NO – GO TO STEP 3.

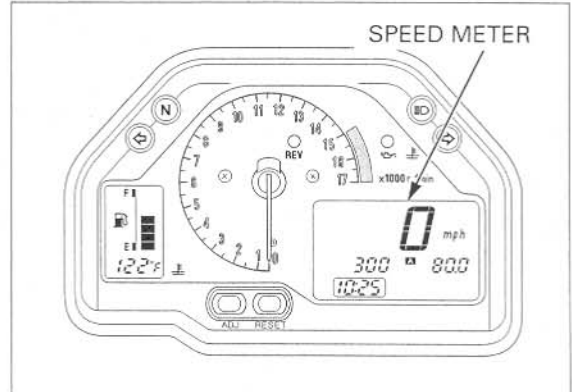

3. Vehicle Speed Sensor Input Voltage Inspection

Turn the ignition switch OFF.
Disconnect the vehicle speed sensor 3P connector.

Turn the ignition switch ON and engine stop switch "Q".

Measure the voltage at the wire harness side.

Connection: Black (+) – Green (-)

Is there battery voltage?

YES – GO TO STEP 4.

NO –

- Open circuit in the Black or Black/brown wire
- Open circuit in the Green or Green/black wire

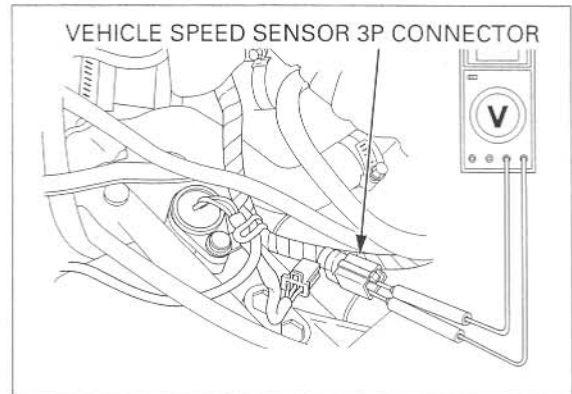

4. Vehicle Speed Sensor Signal Line Short Circuit Inspection

Turn the ignition switch OFF.

Check for continuity between the test harness and the ground.

Connection: B25 – Ground

Is there continuity?

YES – Short circuit in the Pink or Pink/green wire

NO – Inspect the vehicle speed sensor (page 20-13)

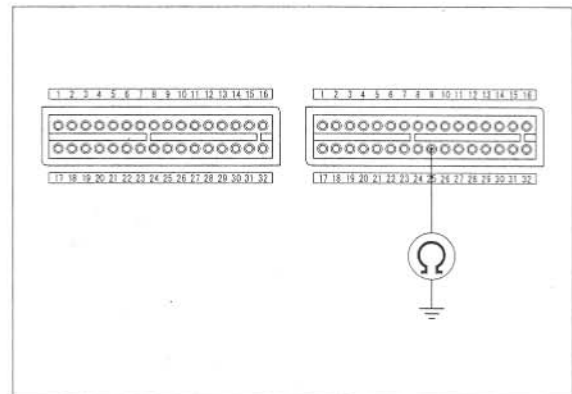

FUEL SYSTEM (Programmed Fuel Injection)

MIL 12 BLINKS (No.1 PRIMARY INJECTOR)

MIL	INJECTOR	POWER INPUT LINE	SIGNAL LINE	SIGNAL AT ECM
12	No.1 Primary	Black/white	Pink/yellow	A11
13	No.2 Primary	Black/white	Pink/blue	A12
14	No.3 Primary	Black/white	Pink/green	A13
15	No.4 Primary	Black/white	Pink/black	A14
16	No.1 Secondary	Black/white	Pink/yellow	B1
17	No.2 Secondary	Black/white	Pink/blue	B2
48	No.3 Secondary	Black/white	Pink/green	B3
49	No.4 Secondary	Black/white	Pink/black	B4

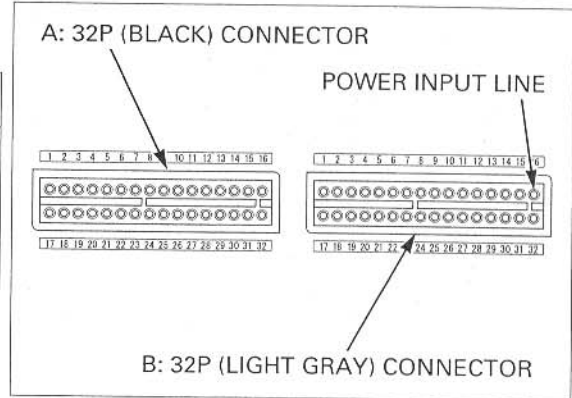

1. Injector Circuit Resistance Inspection

Turn the ignition switch OFF.

Connect the ECM test harness to the ECM connectors (page 6-10).

Measure the resistance at the test harness terminals.

Connection: POWER INPUT LINE – SIGNAL AT ECM

Is there continuity?

YES – GO TO STEP 4.

NO – GO TO STEP 2.

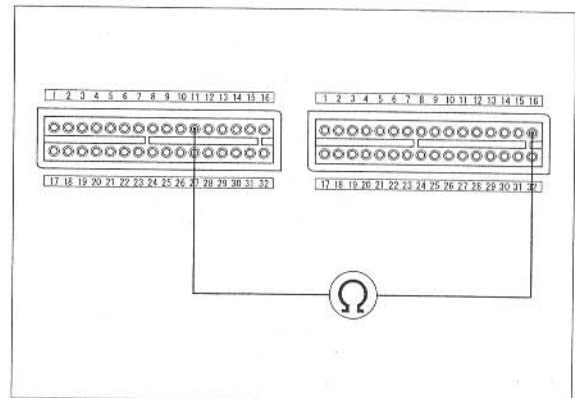

2. Injector Resistance Inspection

Disconnect the No.1 primary injector 2P connector and measure the resistance of the No.1 primary injector 2P connector terminals.

Is the resistance within 11.1 – 12.3 Ω (20°C/68°F)?

YES – GO TO STEP 3.

NO – Faulty injector

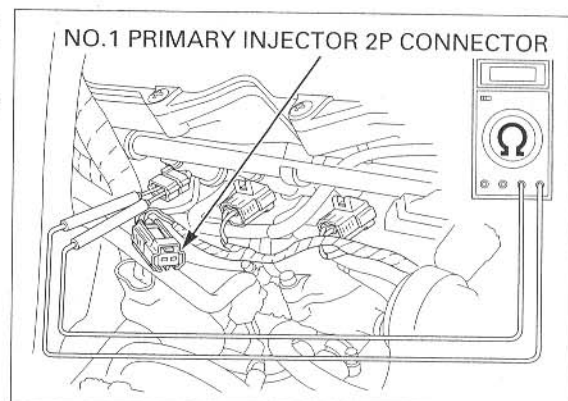

FUEL SYSTEM (Programmed Fuel Injection)

3. Injector Input Voltage Inspection

Turn the ignition switch ON and engine stop switch " \odot ".

Measure the voltage between the No. 1 primary injector connector of the wire harness side and ground.

Connection: POWER INPUT LINE (+) – Ground (-)

Is there battery voltage?

YES – Open circuit in SIGNAL LINE wire

NO – Open circuit in POWER INPUT LINE wire

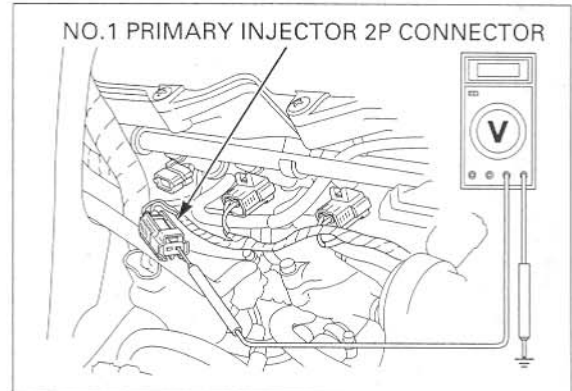

4. Injector Signal Line Short Circuit Inspection

Check for continuity between the test harness terminals and ground.

Connection: SIGNAL AT ECM – Ground

Is there continuity?

YES – • Short circuit in the SIGNAL LINE wire
• Faulty injector

NO – Replace the ECM with a known good one, and recheck

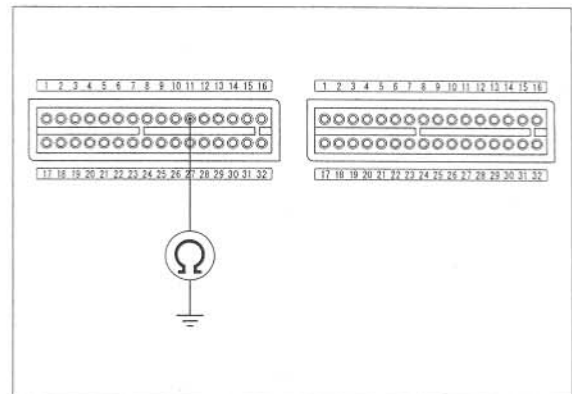

MIL 13 BLINKS (No.2 PRIMARY INJECTOR)

(page 6-24)

MIL 14 BLINKS (No.3 PRIMARY INJECTOR)

(page 6-24)

MIL 15 BLINKS (No.4 PRIMARY INJECTOR)

(page 6-24)

MIL 16 BLINKS (No.1 SECONDARY INJECTOR)

(page 6-24)

MIL 17 BLINKS (No.2 SECONDARY INJECTOR)

(page 6-24)

MIL 48 BLINKS (No.3 SECONDARY INJECTOR)

(page 6-24)

MIL 49 BLINKS (No.4 SECONDARY INJECTOR)

(page 6-24)

FUEL SYSTEM (Programmed Fuel Injection)

MIL 18 BLINKS (CAM PULSE GENERATOR)

- Before starting the inspection, check for loose or poor contact on the cam pulse generator connector and recheck the MIL blinking.

1. Cam Pulse Generator Peak Voltage Inspection at ECM

Turn the ignition switch OFF.
Connect the ECM test harness to the ECM connectors (page 6-10).

Turn the ignition switch ON and engine stop switch "Q".

Crank the engine with the starter motor, and measure the cam pulse generator peak voltage at the test harness terminals.

Connection: B10 (+) – A31 (-)

Is the voltage more than 0.7 V (20 °C/68 °F)?

- YES** –
- Intermittent failure
 - Loose or poor contact on the ECM connectors

NO – GO TO STEP 2.

2. Cam Pulse Generator Peak Voltage Inspection

Turn the ignition switch OFF.
Disconnect the cam pulse generator 2P connector.

Turn the ignition switch ON and engine stop switch "Q".

Crank the engine with the starter motor, and measure the cam pulse generator peak voltage at the cam pulse generator 2P connector.

Connection: Gray (+) – White/yellow (-)

Is the voltage more than 0.7 V (20 °C/68 °F)?

- YES** – Open or short circuit in the Green/orange wire or Gray wire

NO – Faulty cam pulse generator

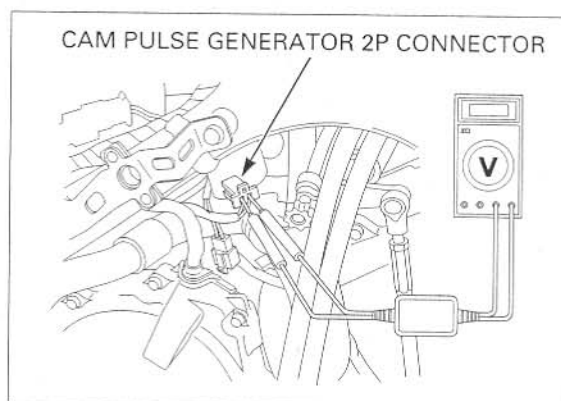
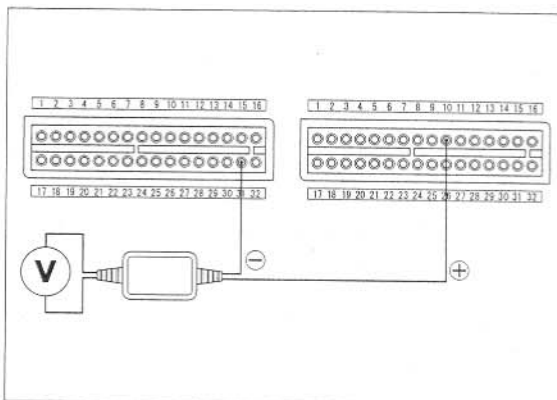

MIL 19 BLINKS (IGNITION PULSE GENERATOR)

- Before starting the inspection, check for loose or poor contact on the ignition pulse generator connector and recheck the MIL blinking.

1. Ignition Pulse Generator Peak Voltage Inspection at ECM

Turn the ignition switch OFF.

Connect the ECM test harness to the ECM connectors (page 6-10).

Turn the ignition switch ON and engine stop switch "Q".

Crank the engine with the starter motor, and measure the ignition pulse generator peak voltage at the test harness terminals.

Connection: B9 (+) – A31 (-)

Is the voltage more than 0.7 V (20 °C/68 °F)?

- YES** –
- Intermittent failure
 - Loose or poor contact on the ECM connectors

NO – GO TO STEP 2.

2. Ignition Pulse Generator Peak Voltage Inspection

Turn the ignition switch OFF.

Lift and support the fuel tank (page 6-61). Disconnect the ignition pulse generator 2P (Red) connector.

Turn the ignition switch ON and engine stop switch "Q".

Crank the engine with the starter motor, and measure the ignition pulse generator peak voltage at the ignition pulse generator 2P (Red) connector.

Connection: Yellow (+) – Yellow/white (-)

Is the voltage more than 0.7 V (20 °C/68 °F)?

- YES** –
- Open or short circuit in the Yellow, Green/orange or Yellow/white wire

NO – Faulty ignition pulse generator

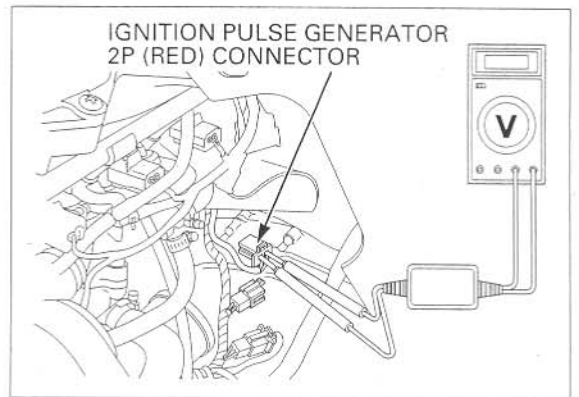
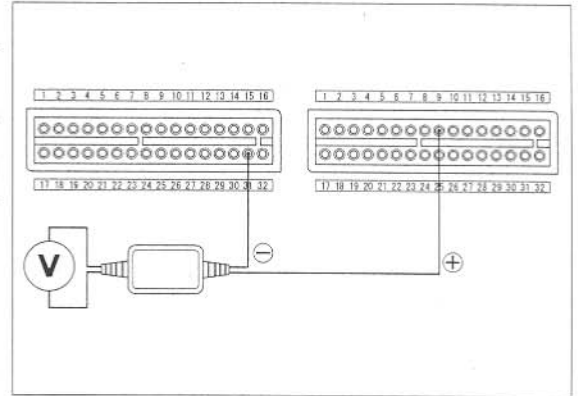

FUEL SYSTEM (Programmed Fuel Injection)

MIL 21 BLINKS (No.1 O₂ SENSOR): California type only

- Before starting the inspection, check for loose or poor contact on the O₂ sensor connector and recheck the MIL blinking.

MIL	O ₂ SEN- SOR	GROUND LINE	SIGNAL LINE	SIGNAL AT ECM
21	No.1 O ₂ Sensor	Green/ orange	Black/red	B13
22	No.2 O ₂ Sensor	Green/ orange	Black/ orange	B28

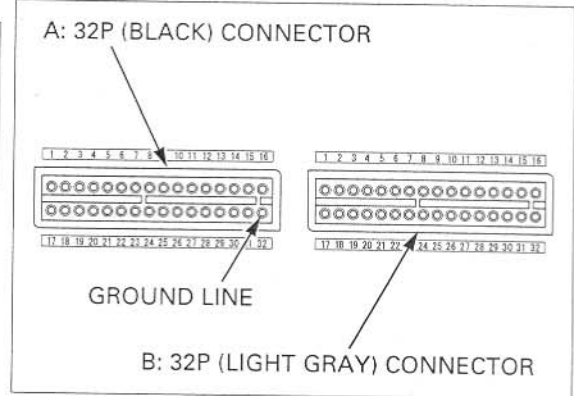

1. O₂ Sensor Output Voltage Inspection

Turn the ignition switch OFF.
Connect the ECM test harness to the ECM connectors (page 6-10).

Turn the ignition switch ON and engine stop switch "Ω".
Warm the engine until the coolant temperature is 80 °C (176 °F).

Check the voltage at the test harness terminal.

Connection: SIGNAL AT ECM (+) – B17 (–)

Standard: 0.1 – 0.3 V

Is the voltage as specified?

YES – Check the fuel pressure (page 6-56). If the system is correct, GO TO STEP 4.

NO – GO TO STEP 2.

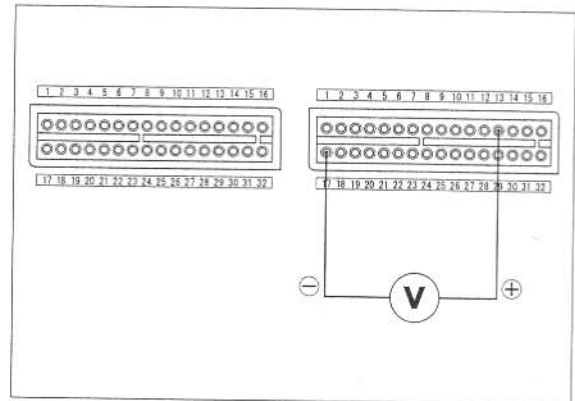

2. O₂ Sensor Open Circuit Inspection

Turn the ignition switch OFF.

Disconnect the O₂ sensor 4P connector.

Check the continuity between the test harness connector terminals and the O₂ sensor 4P connector.

Connection: SIGNAL LINE – SIGNAL AT ECM

Is there continuity?

YES – GO TO STEP 3.

NO – Open circuit in the SIGNAL wire

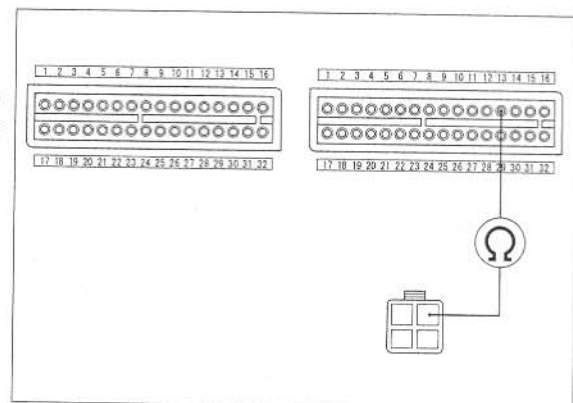

FUEL SYSTEM (Programmed Fuel Injection)

3. O₂ Sensor Short Circuit Inspection

Connect the O₂ Sensor 4P connector.

Check the continuity between the ECM connector terminal and ground.

Connection: SIGNAL AT ECM – Ground

Is there continuity?

YES – Short circuit in the SIGNAL wire

NO – GO TO STEP 4.

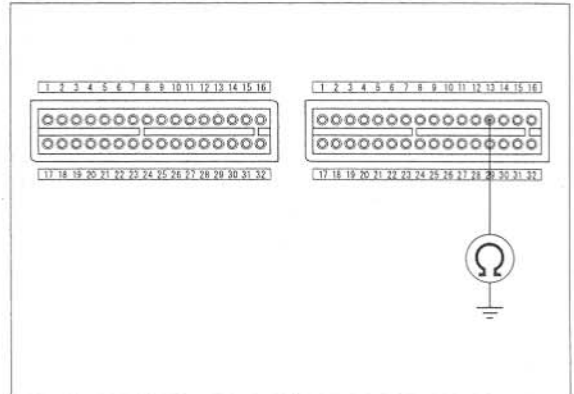

4. O₂ Sensor Inspection

Replace the O₂ sensor with a known good one (page 6-99).

Reset the ECM (page 6-9).

Turn the ignition switch ON and engine stop switch " Ω ".

Warm the engine until the coolant temperature is 80 °C (176 °C).

Check the voltage at the test harness terminal.

Connection: SIGNAL AT ECM (+) – B17 (-)

Standard: 0.1 – 0.3 V

Is the voltage as specified?

YES – Faulty O₂ sensor

NO – Check the fuel supply system (page 2-2).

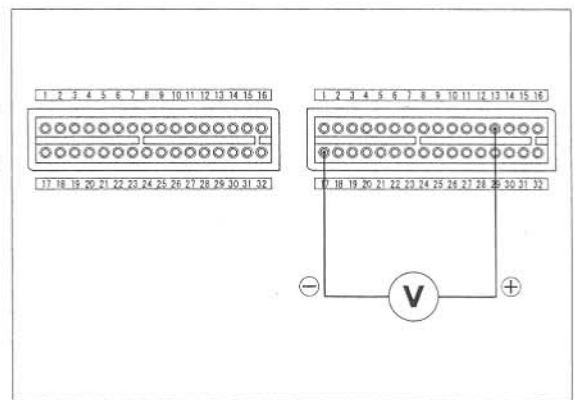

MIL 22 BLINKS (No.2 O₂ SENSOR): California type only

(page 6-28)

FUEL SYSTEM (Programmed Fuel Injection)

MIL 23 BLINKS (No. 1 O₂ SENSOR HEATER): California type only

- Before starting the inspection, check for loose or poor contact on the O₂ sensor connector and recheck the MIL blinking.

MIL	O ₂ Sensor	POWER INPUT LINE	SIGNAL LINE	SIGNAL AT ECM
23	No.1 O ₂ Sensor	Black/white	White	A10
24	No.2 O ₂ Sensor	Black/white	White	A9

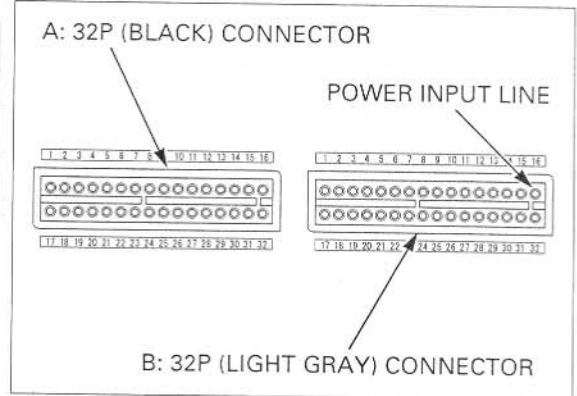

1. O₂ Sensor Heater Resistance Inspection

Turn the ignition switch OFF.

Disconnect the O₂ sensor connector and measure the resistance at the sensor side connector white wire terminal and Green/orange terminal.

Connection: White – Green/orange

Is the resistance within 10 – 40 Ω (20°C/68°F)?

YES – GO TO STEP 2.

NO – Faulty O₂ sensor

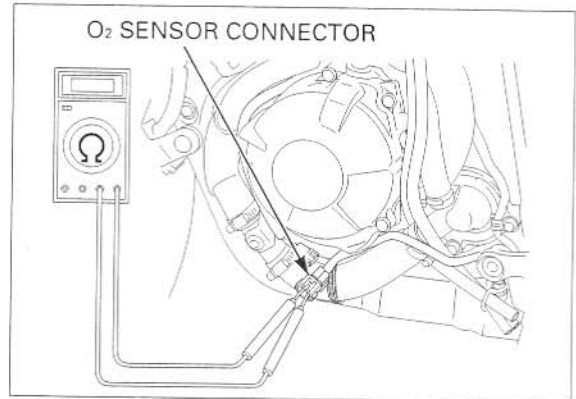

2. O₂ Sensor Heater Open circuit Inspection

Connect the O₂ sensor connector.

Measure the resistance at the test harness terminals.

Connection: POWER INPUT LINE – SIGNAL AT ECM

Is the resistance within 10 – 40 Ω (20°C/68°F)?

YES – GO TO STEP 3.

NO –

- Open circuit in the Black/white wire
- Open circuit in the SIGNAL LINE wire

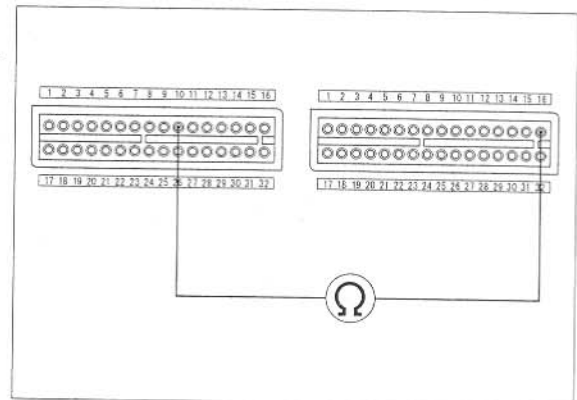

FUEL SYSTEM (Programmed Fuel Injection)

3. O₂ Sensor Heater Short Circuit Inspection 1

Disconnect the O₂ sensor connector.
Check for continuity between the SIGNAL LINE
wire terminal at test harness and ground.

Connection: SIGNAL AT ECM – Ground

Is there continuity?

YES – Short circuit in the SIGNAL LINE wire

NO – GO TO STEP 4.

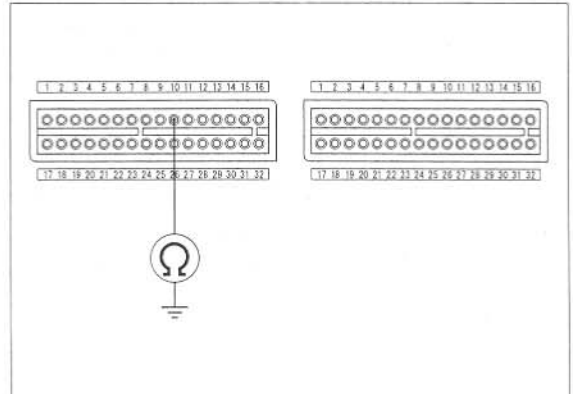

4. O₂ Sensor Heater Short Circuit Inspection 2

Check for continuity between the O₂ sensor con-
nector terminals and ground.

Connection: White – Ground

Is there continuity?

YES – Faulty O₂ sensor

NO – Replace the ECM with a known good
one, and recheck.

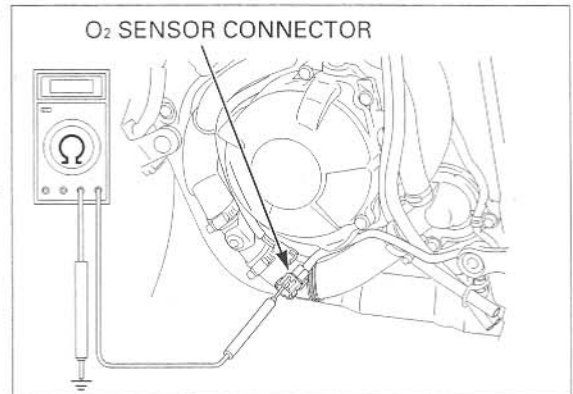

MIL 24 BLINKS (No.2 O₂ SENSOR): California type only

(page 6-30)

FUEL SYSTEM (Programmed Fuel Injection)

MIL 33 BLINKS (E²-PROM)

1. Recheck MIL Blinks 1

Reset the self-diagnosis memory data (page 6-9).
Turn the ignition switch ON and engine stop switch "Q".
Check that the MIL blinks.

Does the MIL blink 33 times?

YES - Replace the ECM with a known good one, and recheck.

NO - GO TO STEP 2.

2. Recheck MIL Blinks 2

Turn the ignition switch OFF.

Short the data link connector with the SCS service connector (070PZ-ZY30100).

Turn the ignition switch ON and engine stop switch "Q".
Check that the MIL blinks.

Does the MIL blink 33 times?

YES - GO TO STEP 3.

NO - Intermittent failure

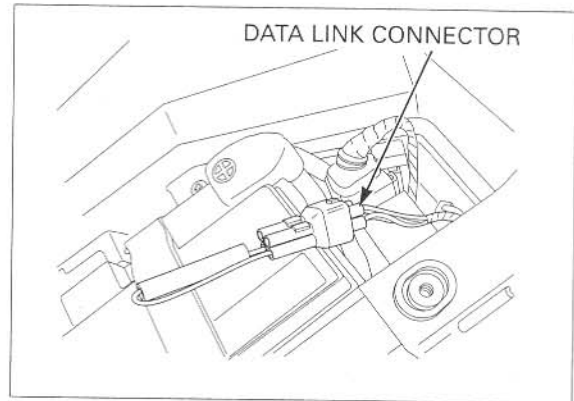

3. Recheck MIL Blinks 3

Reset the self-diagnosis memory data (page 6-9).
Turn the ignition switch ON and engine stop switch "Q".
Check that the MIL blinks.

Does the MIL blink 33 times?

YES - Replace the ECM with a known good one, and recheck.

NO - Intermittent failure

DTC CODE INDEX

- The Diagnostic Trouble Codes (DTC) are based upon Malfunction Indicator Lamp (MIL) codes and are displayed as hyphenated numbers. The digits in front of the hyphen are equal to an MIL code and indicate the Function Failure. The digit behind the hyphen details the symptom. For example, in the case of the TP sensor, the ECM stores two levels of information, a function failure and a detail of the symptom:
 (08 - 1) = TP sensor voltage - *lower* than the specified value
 or
 (08 - 2) = TP sensor voltage - *higher* than the specified value.
- The MAP, ECT, TP and IAT sensor diagnoses will be made according to the voltage output of the affected sensor. If a failure occurs, the ECM determines the Function Failure, compares the sensor voltage output to the standard value, and then outputs the corresponding DTC to the HDS Pocket Tester
 For example:
 - If the input voltage line (A) on the MAP sensor is opened, the ECM detects the output voltage is about 5 V, then the DTC 1-2 (MAP sensor circuit high voltage) will be displayed.
 - If the input voltage line (B) on the TP sensor is opened, the ECM detects the output voltage is 0 V, then the DTC 8-1 (TP sensor circuit low voltage) will be displayed.

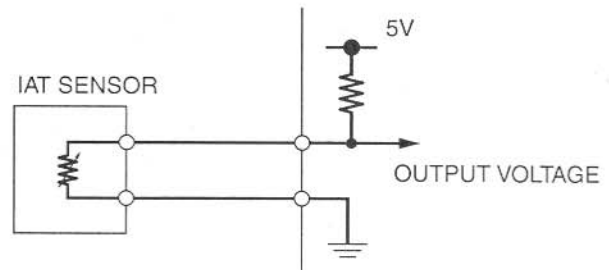
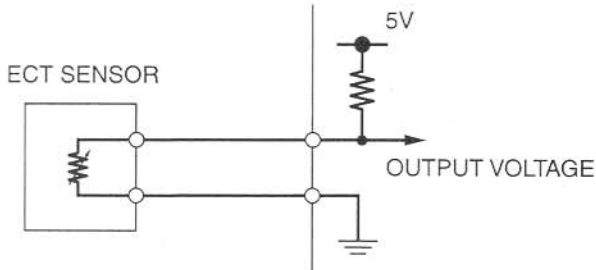
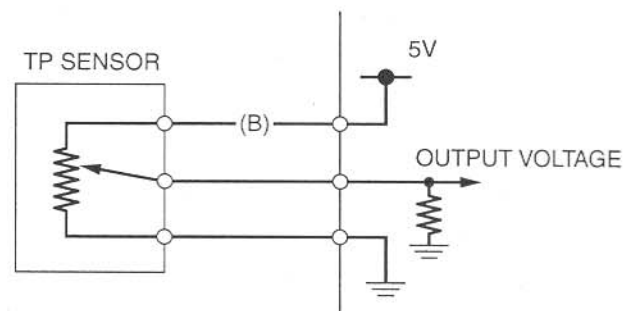
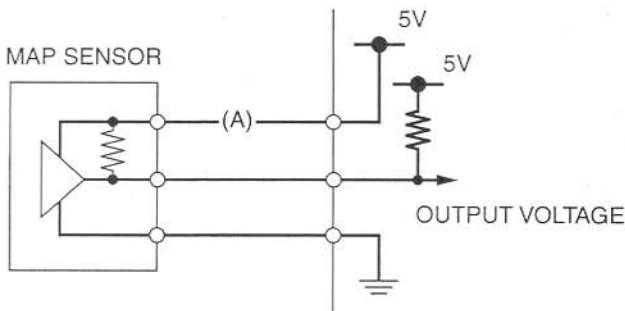

FUEL SYSTEM (Programmed Fuel Injection)

DTC	Function Failure	Causes	Symptoms	Refer to
-	ECM malfunction	<ul style="list-style-type: none"> Faulty ECM 	<ul style="list-style-type: none"> Engine does not start MIL does not blink 	6-94
-	ECM power input circuit malfunction	<ul style="list-style-type: none"> Open circuit at the power input wire of the ECM Faulty bank angle sensor Open circuit in bank angle sensor related circuit Faulty engine stop relay Open circuit in engine stop relay related wires Faulty engine stop switch Open circuit in engine stop switch related wires Faulty ignition switch Blown PGM-FI fuse (20 A) Blown sub-fuse (10 A) (Starter, Bank angle sensor) 	<ul style="list-style-type: none"> Engine does not start MIL does not blink 	6-94
-	ECM output line malfunction	<ul style="list-style-type: none"> ECM output voltage line (Yellow/red wire) short circuit 	<ul style="list-style-type: none"> Engine does not start 	-
-	MIL circuit malfunction	<ul style="list-style-type: none"> Faulty ECM Open or short circuit in MIL wire 	<ul style="list-style-type: none"> Engine operates normally MIL does not blink 	6-8
-	Data link circuit malfunction	<ul style="list-style-type: none"> Short circuit in data link connector Faulty ECM Short circuit in data link connector wire 	<ul style="list-style-type: none"> Engine operates normally MIL stays lit 	-
1-1	MAP sensor circuit low voltage	<ul style="list-style-type: none"> Open or short circuit in MAP sensor wire Faulty MAP sensor 	<ul style="list-style-type: none"> Engine operates normally 	6-37
1-2	MAP sensor circuit high voltage	<ul style="list-style-type: none"> Loose or poor contact on MAP sensor connector Open circuit in MAP sensor wire Faulty MAP sensor 	<ul style="list-style-type: none"> Engine operates normally 	6-38
2-1	MAP sensor performance problem	<ul style="list-style-type: none"> Loose or poor connection of the MAP sensor vacuum hose Faulty MAP sensor 	<ul style="list-style-type: none"> Engine operates normally 	6-39
7-1	ECT sensor circuit low voltage	<ul style="list-style-type: none"> Short circuit in ECT sensor wire Faulty ECT sensor 	<ul style="list-style-type: none"> Hard start at a low temperature (Simulate using numerical values; 90 °C/194 °F) 	6-40
7-2	ECT sensor circuit high voltage	<ul style="list-style-type: none"> Loose or poor contact on ECT sensor Open circuit in ECT sensor wire Faulty ECT sensor 	<ul style="list-style-type: none"> Hard start at a low temperature (Simulate using numerical values; 90 °C/194 °F) 	6-40
8-1	TP sensor circuit low voltage	<ul style="list-style-type: none"> Loose or poor contact on TP sensor connector Open or short circuit in TP sensor wire Faulty TP sensor 	<ul style="list-style-type: none"> Poor engine performance and response when operating the throttle quickly (Simulate using numerical values; Throttle opens 0°) 	6-42
8-2	TP sensor circuit high voltage	<ul style="list-style-type: none"> Open circuit in TP sensor wire Faulty TP sensor 	<ul style="list-style-type: none"> Poor engine performance and response when operating the throttle quickly (Simulate using numerical values; Throttle opens 0°) 	6-43
9-1	IAT sensor circuit low voltage	<ul style="list-style-type: none"> Short circuit in IAT sensor wire Faulty IAT sensor 	<ul style="list-style-type: none"> Engine operates normally (Simulate using numerical values; 25 °C/77 °F) 	6-44
9-2	IAT sensor circuit high voltage	<ul style="list-style-type: none"> Loose or poor contact on IAT sensor Open circuit in IAT sensor wire Faulty IAT sensor 	<ul style="list-style-type: none"> Engine operates normally (Simulate using numerical values; 25 °C/77 °F) 	6-45

FUEL SYSTEM (Programmed Fuel Injection)

DTC	Function Failure	Causes	Symptoms	Refer to
11-1	Vehicle speed sensor no signal (circuit malfunction)	<ul style="list-style-type: none"> • Loose or poor contact on vehicle speed sensor connector • Open or short circuit in vehicle speed sensor connector • Faulty vehicle speed sensor 	<ul style="list-style-type: none"> • Engine operates normally 	6-46
12-1	No.1 Primary injector circuit malfunction	<ul style="list-style-type: none"> • Loose or poor contact on No.1 Primary injector connector • Open or short circuit in No.1 Primary injector wire • Faulty No.1 Primary injector 	<ul style="list-style-type: none"> • Engine does not start 	6-47
13-1	No.2 Primary injector circuit malfunction	<ul style="list-style-type: none"> • Loose or poor contact on No.2 Primary injector connector • Open or short circuit in No.2 Primary injector wire • Faulty No.2 Primary injector 	<ul style="list-style-type: none"> • Engine does not start 	6-49
14-1	No.3 Primary injector circuit malfunction	<ul style="list-style-type: none"> • Loose or poor contact on No.3 Primary injector connector • Open or short circuit in No.3 Primary injector wire • Faulty No.3 Primary injector 	<ul style="list-style-type: none"> • Engine does not start 	6-49
15-1	No.4 Primary injector circuit malfunction	<ul style="list-style-type: none"> • Loose or poor contact on No.4 Primary injector connector • Open or short circuit in No.4 Primary injector wire • Faulty No.4 Primary injector 	<ul style="list-style-type: none"> • Engine does not start 	6-49
16-1	No.1 Secondary injector circuit malfunction	<ul style="list-style-type: none"> • Loose or poor contact on No.1 Secondary injector connector • Open or short circuit in No.1 Secondary injector wire • Faulty No.1 Secondary injector 	<ul style="list-style-type: none"> • Engine does not start 	6-49
17-1	No.2 Secondary injector circuit malfunction	<ul style="list-style-type: none"> • Loose or poor contact on No.2 Secondary injector connector • Open or short circuit in No.2 Secondary injector wire • Faulty No.2 Secondary injector 	<ul style="list-style-type: none"> • Engine does not start 	6-49
18-1	Cam pulse generator no signal	<ul style="list-style-type: none"> • Loose or poor contact on cam pulse generator • Open or short circuit in cam pulse generator • Faulty cam pulse generator 	<ul style="list-style-type: none"> • Engine does not start 	6-50
19-1	Ignition pulse generator no signal	<ul style="list-style-type: none"> • Loose or poor contact on ignition pulse generator • Open or short circuit in ignition pulse generator • Faulty ignition pulse generator 	<ul style="list-style-type: none"> • Engine does not start 	6-51
21-1	No.1 O ₂ sensor circuit malfunction (California type only)	<ul style="list-style-type: none"> • Loose or poor contact on O₂ sensor connector • Short circuit in O₂ sensor • Faulty O₂ sensor 	<ul style="list-style-type: none"> • Engine operates normally 	6-52
22-1	No.2 O ₂ sensor circuit malfunction (California type only)	<ul style="list-style-type: none"> • Loose or poor contact on O₂ sensor connector • Short circuit in O₂ sensor • Faulty O₂ sensor 	<ul style="list-style-type: none"> • Engine operates normally 	6-53
23-1	No.1 O ₂ sensor heater malfunction (California type only)	<ul style="list-style-type: none"> • Loose or poor contact on O₂ sensor connector • Open or short circuit in O₂ sensor heater • Faulty O₂ sensor 	<ul style="list-style-type: none"> • Engine operates normally 	6-54
24-1	No.2 O ₂ sensor heater malfunction (California type only)	<ul style="list-style-type: none"> • Loose or poor contact on O₂ sensor connector • Open or short circuit in O₂ sensor heater • Faulty O₂ sensor 	<ul style="list-style-type: none"> • Engine operates normally 	6-55

FUEL SYSTEM (Programmed Fuel Injection)

DTC	Function Failure	Causes	Symptoms	Refer to
33-1	E ² -PROM in ECM malfunction	<ul style="list-style-type: none">Faulty ECM	<ul style="list-style-type: none">Engine operates normallyDoes not hold the self-diagnosis data	6-55
48-1	No.3 Secondary injector circuit malfunction	<ul style="list-style-type: none">Loose or poor contact on No.3 Secondary injector connectorOpen or short circuit in No.3 Secondary injector wireFaulty No.3 Secondary injector	<ul style="list-style-type: none">Engine does not start	6-49
49-1	No.4 Secondary injector circuit malfunction	<ul style="list-style-type: none">Loose or poor contact on No.4 Secondary injector connectorOpen or short circuit in No.4 Secondary injector wireFaulty No.4 Secondary injector	<ul style="list-style-type: none">Engine does not start	6-49

DTC TROUBLESHOOTING

DTC 1-1 (MAP SENSOR LOW VOLTAGE)

1. MAP Sensor System Inspection

Turn the ignition switch ON and engine stop switch " \odot ".
Check the MAP sensor with the HDS.

Is about 0 V or below indicated?

YES – GO TO STEP 2.

NO – • Intermittent failure
• Loose or poor contact on the MAP sensor connector

2. MAP Sensor Input Voltage Inspection

Turn the ignition switch OFF.
Disconnect the MAP sensor 3P connector.
Turn the ignition switch ON and engine stop switch " \odot ".
Measure the voltage at the wire harness side.

Connection: Yellow/red (+) – Green/orange (-)

Is the voltage within 4.75 – 5.25V?

YES – GO TO STEP 4.

NO – GO TO STEP 3.

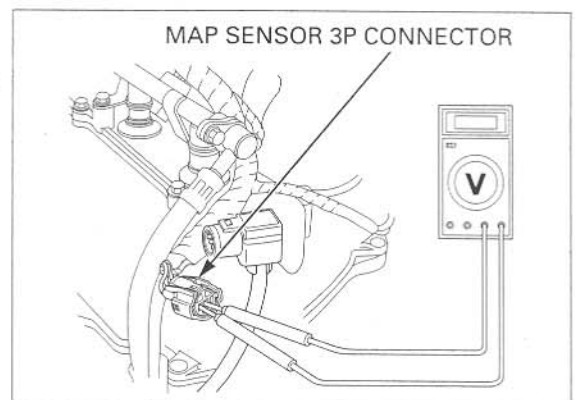

3. MAP Sensor Input Line Inspection

Turn the ignition switch OFF.
Disconnect the ECM 32P connectors.

Check for continuity at the Yellow/red wire between the MAP sensor 3P connector terminal and the ECM 32P (Light gray) connector.

Connection: B18 – Yellow/red

Is there continuity?

YES – Replace the ECM with a known good one, and recheck.

NO – Open circuit in Yellow/red wire

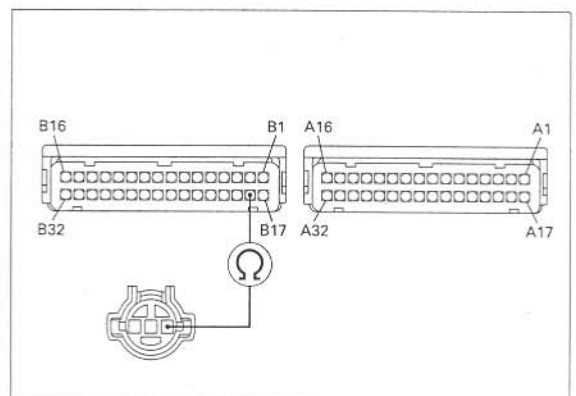

4. MAP Sensor Output Line Short Circuit Inspection

Check for continuity between the MAP sensor 3P connector terminal of the wire harness side and ground.

Connection: Light green/yellow – Ground

Is there continuity?

YES – Short circuit in Light green/yellow wire

NO – GO TO STEP 5.

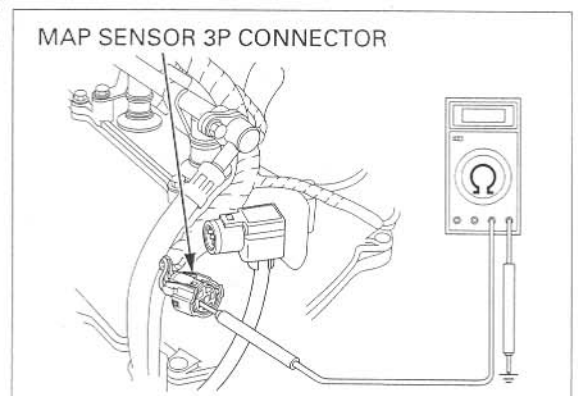

FUEL SYSTEM (Programmed Fuel Injection)

5. MAP Sensor Inspection

Replace the MAP sensor with a known good one (page 6-88).

Reset the ECM (page 6-9).

Turn the ignition switch ON and engine stop switch "Q".

Check the MAP sensor with the HDS.

Is DTC 1-1 indicated?

YES – Replace the ECM with a known good one, and recheck

NO – Faulty original MAP sensor

DTC 1-2 (MAP SENSOR HIGH VOLTAGE)

- Before starting the inspection, check for loose or poor contact on the MAP sensor connector and recheck the DTC.

1. MAP Sensor System Inspection 1

Turn the ignition switch ON and engine stop switch "Q".

Check the MAP sensor with the HDS.

Is about 5 V indicated?

YES – GO TO STEP 2.

NO – • Intermittent failure
• Loose or poor contact on the MAP sensor connector

2. MAP Sensor System Inspection 2

Turn the ignition switch OFF.

Disconnect the MAP sensor 3P connector. Connect the MAP sensor terminals at the wire harness side with a jumper wire.

Connection: Light green/yellow – Green/orange

Turn the ignition switch ON and engine stop switch "Q".

Check the MAP sensor with the HDS.

Is about 0 V indicated?

YES – Faulty MAP sensor

NO – GO TO STEP 3.

3. MAP Sensor Input Voltage Inspection

Turn the ignition switch OFF.

Remove the jumper wire.

Turn the ignition switch ON and engine stop switch "Q".

Measure the voltage at the wire harness side.

Connection: Yellow/red (+) – Green/orange (–)

Is the voltage within 4.75 – 5.25V?

YES – GO TO STEP 4.

NO – Open circuit in Green/orange wire

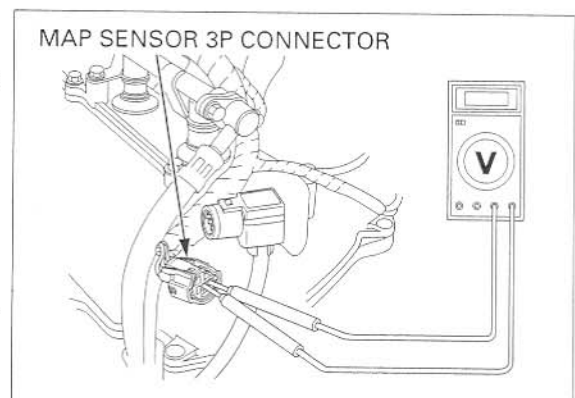
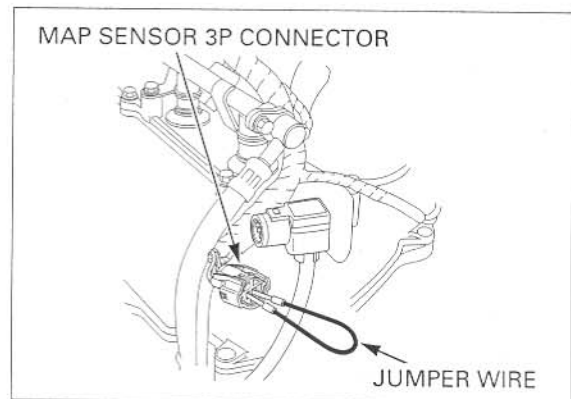

FUEL SYSTEM (Programmed Fuel Injection)

4. MAP Sensor Output Line Open Circuit Inspection

Disconnect the ECM 32P connectors.
Check for continuity at the Light green/yellow wire between the MAP sensor 3P connector terminal and the ECM 32P (Light gray) connector.

Connection: B15 – Light green/yellow

Is there continuity?

YES – Replace the ECM with a known good one, and recheck

NO – Open circuit in Light green/yellow wire

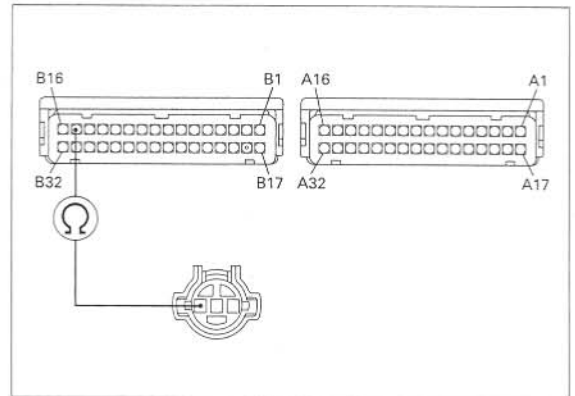

DTC 2-1 (MAP SENSOR)

- Before starting the inspection, check for loose or poor contact on the MAP sensor connector and recheck the DTC.

1. MAP Sensor System Inspection

Turn the ignition switch ON and engine stop switch " \odot ".

Start the engine and check the MAP sensor with the HDS at idle speed.

Is 1.6 V indicated?

YES – Intermittent failure

NO – GO TO STEP 2.

2. Manifold Absolute Pressure Test

Turn the ignition switch OFF.

Check for connection and installation of the MAP sensor vacuum hose.

Is the MAP sensor vacuum hose connection correct?

YES – GO TO STEP 3.

NO – Correct the hose installation

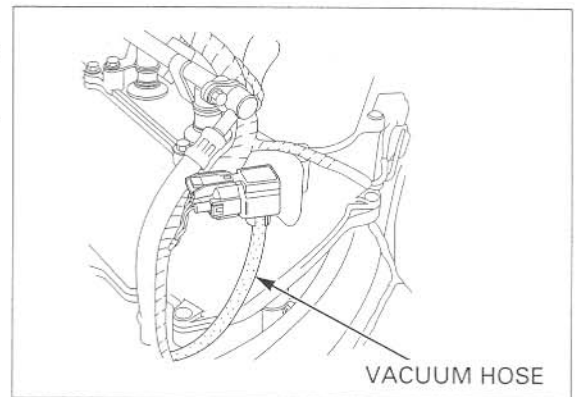

3. MAP Sensor System Inspection

Replace the MAP sensor with a known good one (page 6-88).

Turn the ignition switch ON and engine stop switch " \odot ".

Start the engine and check the MAP sensor with the HDS at idle speed.

Is 1.6 V indicated?

YES – Faulty original MAP sensor

NO – Replace the ECM with a known good one, and recheck.

FUEL SYSTEM (Programmed Fuel Injection)

DTC 7-1 (ECT SENSOR LOW VOLTAGE)

1. ECT Sensor System Inspection

Turn the ignition switch ON and engine stop switch " \odot ".

Check the ECT sensor with the HDS.

Is about 0 V indicated?

YES – GO TO STEP 2.

NO – • Intermittent failure
• Loose or poor contact on the ECT sensor connector

2. ECT Sensor Inspection

Turn the ignition switch OFF.
Disconnect the ECT sensor 3P connector.

Turn the ignition switch ON and engine stop switch " \odot ".

Check the ECT sensor with the HDS.

Is about 0 V indicated?

YES – GO TO STEP 3.

NO – Faulty ECT sensor

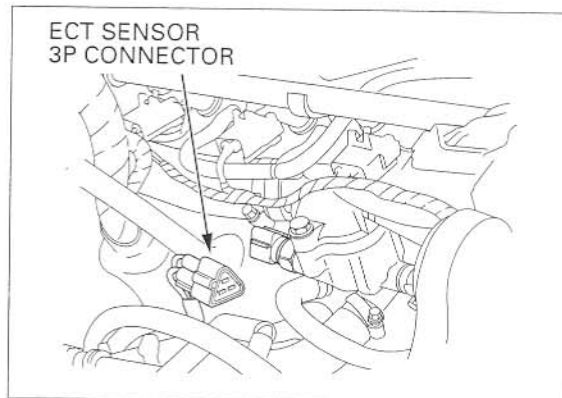

3. ECT Sensor Output Line Short Circuit Inspection

Turn the ignition switch OFF.

Check for continuity between the ECT sensor 3P connector terminal of the wire harness side and ground.

Connection: Pink – Ground

Is there continuity?

YES – Short circuit in Pink wire

NO – Replace the ECM with a known good one, and recheck.

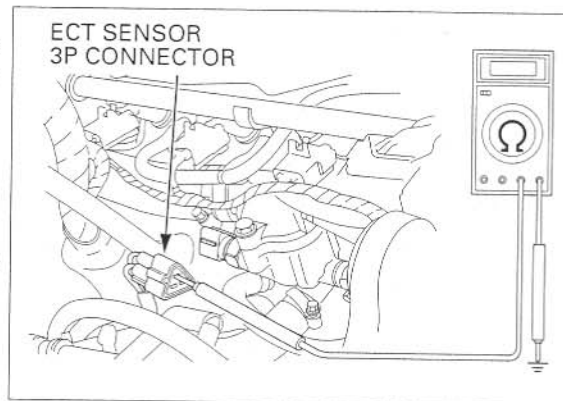

DTC 7-2 (ECT SENSOR HIGH VOLTAGE)

- Before starting the inspection, check for loose or poor contact on the ECT sensor connector and recheck the DTC.

1. ECT Sensor System Inspection

Turn the ignition switch ON and engine stop switch " \odot ".

Check the ECT sensor with the HDS.

Is about 5 V indicated?

YES – GO TO STEP 2.

NO – • Intermittent failure
• Loose or poor contact on the ECT sensor connector

FUEL SYSTEM (Programmed Fuel Injection)

2. ECT Sensor Inspection

Turn the ignition switch OFF.

Disconnect the ECT sensor 3P connector.
Connect the ECT sensor terminals with a jumper wire.

Connection: Pink – Green/orange

Turn the ignition switch ON and engine stop switch " Ω ".

Check the ECT sensor with the HDS.

Is about 0 V indicated?

YES – Inspect the ECT sensor (page 20-16)

NO – GO TO STEP 3.

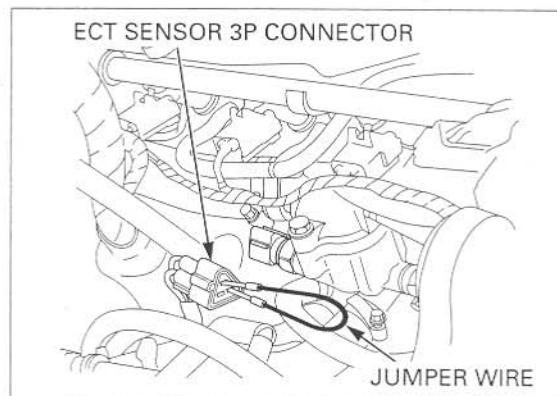

3. ECT Sensor Output Line Inspection

Turn the ignition switch OFF.

Remove the jumper wire.

Disconnect the ECM 32P connectors.

Check for continuity at the Pink (ECM side: Pink/white) and Green/orange wires between the ECT sensor 3P connector terminal and the ECM 32P (Light gray) connector.

Connection: B27 – Pink

B17 – Green/orange

Are there continuity?

YES – Replace the ECM with a known good one, and recheck

NO –

- Open circuit in Pink or Pink/white wire
- Open circuit in Green/orange wire

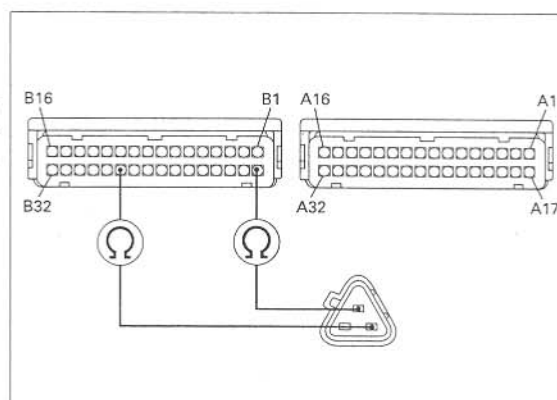

FUEL SYSTEM (Programmed Fuel Injection)

DTC 8-1 (TP SENSOR LOW VOLTAGE)

- Before starting the inspection, check for loose or poor contact on the TP sensor connector and recheck the DTC.

1. TP Sensor System Inspection

Turn the ignition switch ON and engine stop switch "Ⓞ".

Check the TP sensor with the HDS when the throttle fully closed.

Is about 0 V indicated?

- YES** – • Intermittent failure
• Loose or poor contact on the MAP sensor connector

NO – GO TO STEP 2.

2. TP Sensor Input Voltage Inspection

Turn the ignition switch OFF.
Disconnect the TP sensor 3P connector.

Turn the ignition switch ON and engine stop switch "Ⓞ".

Measure the voltage at the wire harness side.

Connection: Yellow/red (+) – Green/orange (–)

Is the voltage within 4.75 – 5.25 V?

YES – GO TO STEP 4.

NO – GO TO STEP 3.

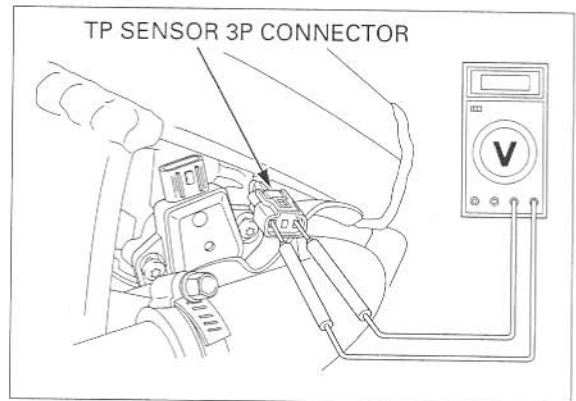

3. TP Sensor Circuit Inspection

Disconnect the ECM 32P connectors.
Check for continuity at the Yellow/red wire between the TP sensor 3P connector terminal and the ECM 32P (Light gray) connector.

Connection: B18 – Yellow/red

Is there continuity?

YES – Replace the ECM with a known good one, and recheck

NO – Open circuit in Yellow/red wire

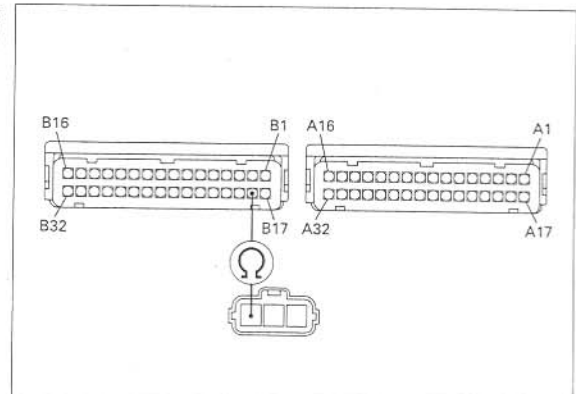

FUEL SYSTEM (Programmed Fuel Injection)

4. TP Sensor Output Line Open Circuit Inspection

Check for continuity at the Red/yellow wire between the TP sensor 3P connector terminal and the ECM 32P (Light gray) connector.

Connection: B14 – Red/yellow

Is there continuity?

YES – GO TO STEP 5.

NO – Open circuit in Red/yellow wire

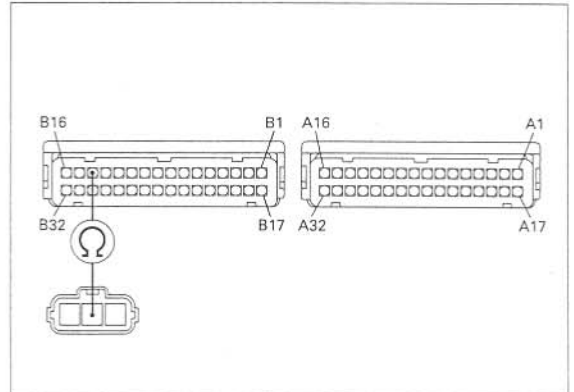

5. TP Sensor Output Line Short Circuit Inspection

Disconnect the TP sensor 3P connector.

Check for continuity between the TP sensor 3P connector terminal of the wire harness side and ground.

Connection: Red/yellow – Ground

Is there continuity?

YES – Short circuit in Red/yellow wire

NO – GO TO STEP 6.

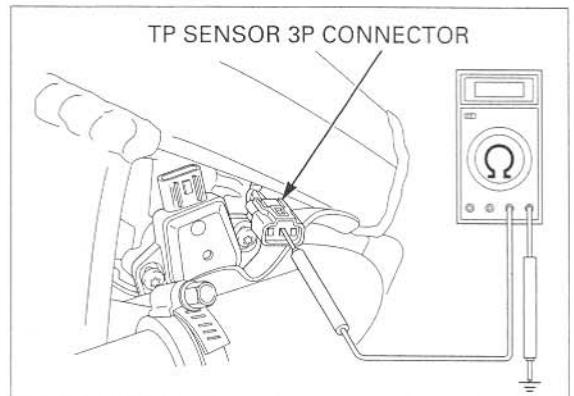

6. TP Sensor Inspection

Replace the TP sensor with a known good one.
Reset the ECM (page 6-9).
Turn the ignition switch ON and engine stop switch " Ω ".

Check the TP sensor with the HDS.

Is DTC 8-1 indicated?

YES – Replace the ECM with a known good one, and recheck

NO – Faulty original TP sensor

DTC 8-2 (TP SENSOR HIGH VOLTAGE)

1. TP Sensor System Inspection

Turn the ignition switch ON and engine stop switch " Ω ".

Check the TP sensor with the HDS.

Is about 5 V indicated?

YES – GO TO STEP 2.

NO –

- Intermittent failure
- Loose or poor contact on the TP sensor connector

FUEL SYSTEM (Programmed Fuel Injection)

2. TP Sensor Resistance Inspection

Turn the ignition switch OFF.

Disconnect the TP sensor 3P connector.
Measure the resistance at the TP sensor side.

Connection: Red/yellow – Green/orange

Is the resistance within 0.4 - 0.6 Ω ?

YES – GO TO STEP 3.

NO – Faulty TP sensor

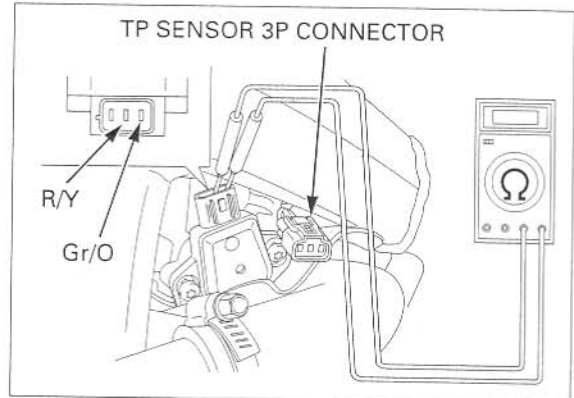

3. TP Sensor Input Voltage Inspection

Turn the ignition switch ON and engine stop switch " Ω ".
Measure the voltage at the wire harness side.

Connection: Yellow/red (+) – Green/orange (-)

Is the voltage within 4.75 – 5.25 V?

YES – Replace the ECM with a known good one, and recheck

NO – Open circuit in Green/orange wires

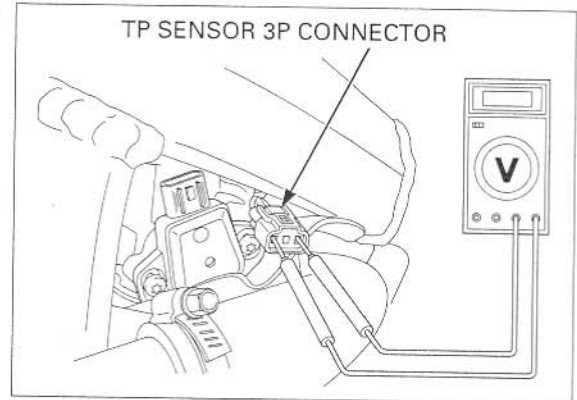

DTC 9-1 (IAT SENSOR LOW VOLTAGE)

1. IAT Sensor System Inspection

Turn the ignition switch ON and engine stop switch " Ω ".

Check the IAT sensor with the HDS.

Is about 0 V indicated?

YES – GO TO STEP 2.

NO – • Intermittent failure
• Loose or poor contact on the IAT sensor connector

2. IAT Sensor Inspection

Turn the ignition switch OFF.
Disconnect the IAT sensor 2P connector.

Turn the ignition switch ON and engine stop switch " Ω ".

Check the IAT sensor with the HDS.

Is about 0 V indicated?

YES – GO TO STEP 3.

NO – Faulty IAT sensor

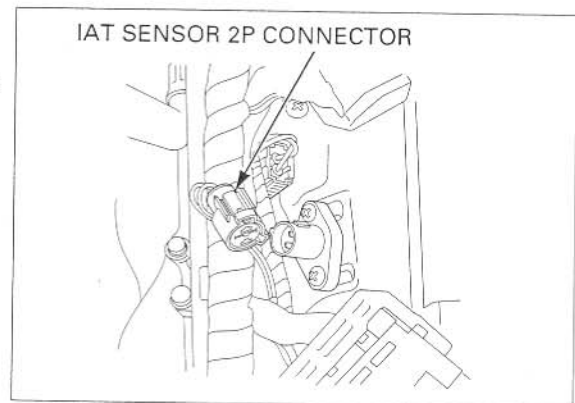

FUEL SYSTEM (Programmed Fuel Injection)

3. IAT Sensor Output Line Short Circuit Inspection

Check for continuity between the IAT sensor 2P connector terminal of the wire harness side and ground.

Connection: Gray/blue – Ground

Is there continuity?

YES – Short circuit in Gray/blue wire

NO – Replace the ECM with a known good one, and recheck

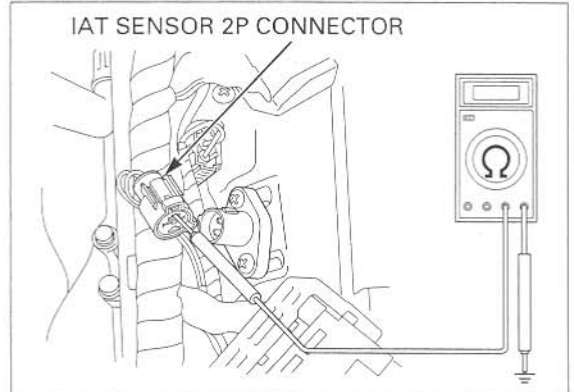

DTC 9-2 (IAT SENSOR HIGH VOLTAGE)

- Before starting the inspection, check for loose or poor contact on the IAT sensor connector and recheck the DTC.

1. IAT Sensor System Inspection

Turn the ignition switch ON and engine stop switch "Q".

Check the IAT sensor with the HDS.

Is about 5 V indicated?

YES – GO TO STEP 2.

NO –

- Intermittent failure
- Loose or poor contact on the IAT sensor connector

2. IAT Sensor Inspection

Turn the ignition switch OFF.

Disconnect the IAT sensor 2P connector. Connect the IAT sensor terminals with a jumper wire.

Connection: Gray/blue – Green/orange

Turn the ignition switch ON and engine stop switch "Q".

Check the IAT sensor with the HDS.

Is about 0 V indicated?

YES – Faulty IAT sensor

NO – GO TO STEP 3.

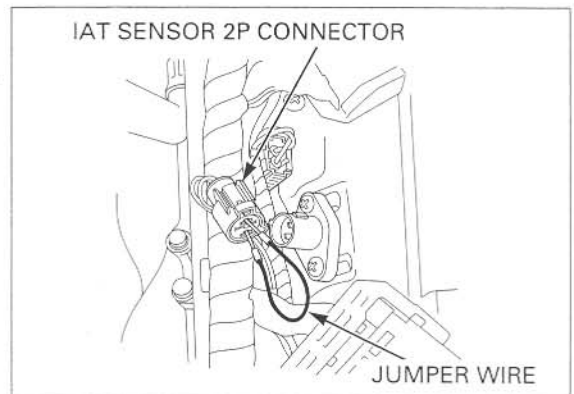

3. IAT Sensor Output Line Inspection

Disconnect the ECM 32P connectors. Check for continuity at the Gray/blue and Green/orange wire between the IAT sensor 2P connector terminals and the ECM 32P (Light gray) connector.

Connection: B17 – Gray/blue
B30 – Green/orange

Are there continuity?

YES – Replace the ECM with a known good one, and recheck.

NO –

- Open circuit in Gray/blue wire
- Open circuit in Green/orange wire

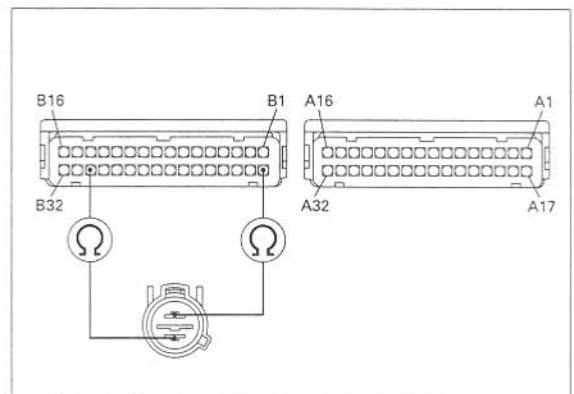

FUEL SYSTEM (Programmed Fuel Injection)

DTC 11-1 (VEHICLE SPEED SENSOR)

- Before starting the inspection, check for loose or poor contact on the vehicle speed sensor connector and recheck the DTC.

1. Vehicle Speed Sensor System Inspection

Support the motorcycle securely and place the rear wheel off the ground.

Start the engine and shift the transmission into gear.

Check the vehicle speed sensor with the HDS at 10 km/h.

Is 10 km/h indicated?

- YES** –
- Intermittent failure
 - Loose or poor contact on the vehicle speed sensor connector

NO – GO TO STEP 2.

2. Combination Meter Inspection

Check for operation of speed meter.

Does the speed meter operate normally?

- YES** – Open or short circuit in the Pink/green wire

NO – GO TO STEP 3.

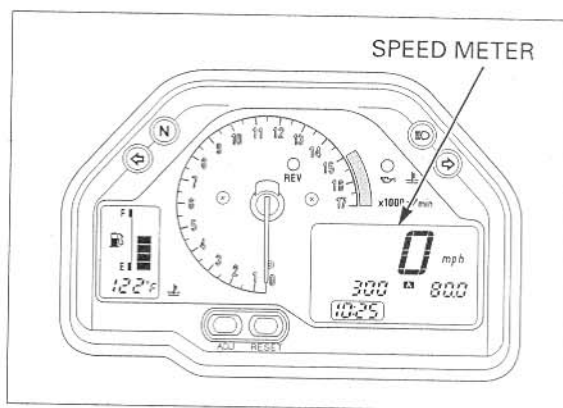

3. Vehicle Speed Sensor Input Voltage Inspection

Turn the ignition switch OFF.

Disconnect the vehicle speed sensor 3P connector.

Turn the ignition switch ON and engine stop switch "Q".

Measure the voltage at the wire harness side.

Connection: Black (+) – Green (-)

Is there battery voltage?

YES – GO TO STEP 4.

- NO** –
- Open circuit in the Black or Black/brown wire
 - Open circuit in the Green or Green/black wire

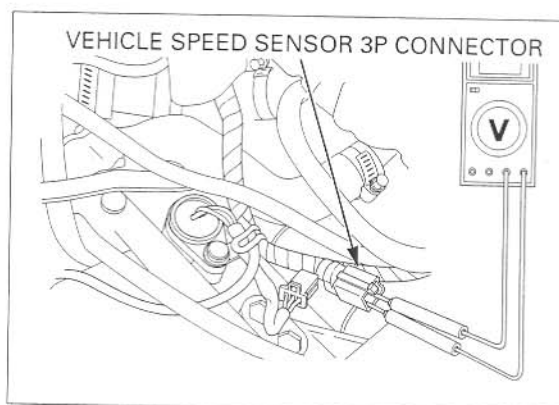

FUEL SYSTEM (Programmed Fuel Injection)

4. Vehicle Speed Sensor Signal Line Short Circuit Inspection

Turn the ignition switch OFF.
Disconnect the ECM 32P connectors.

Check for continuity between the ECM 32P (Light gray) connector terminal and the ground.

Connection: B25 – Ground

Is there continuity?

YES – Short circuit in the Pink or Pink/green wire

NO – Inspect vehicle speed sensor (page 20-13)

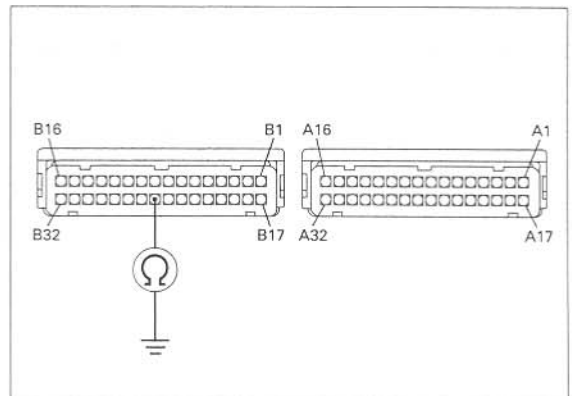

DTC 12-1 (No.1 PRIMARY INJECTOR)

- Before starting the inspection, check for loose or poor contact on the Primary injector connectors and recheck the DTC.

DTC	INJECTOR	POWER INPUT LINE	SIGNAL LINE	SIGNAL AT ECM
12-1	No.1 Primary	Black/white	Pink/yellow	A11
13-1	No.2 Primary	Black/white	Pink/blue	A12
14-1	No.3 Primary	Black/white	Pink/green	A13
15-1	No.4 Primary	Black/white	Pink/black	A14
16-1	No.1 Secondary	Black/white	Pink/yellow	B1
17-1	No.2 Secondary	Black/white	Pink/blue	B2
48-1	No.3 Secondary	Black/white	Pink/green	B3
49-1	No.4 Secondary	Black/white	Pink/black	B4

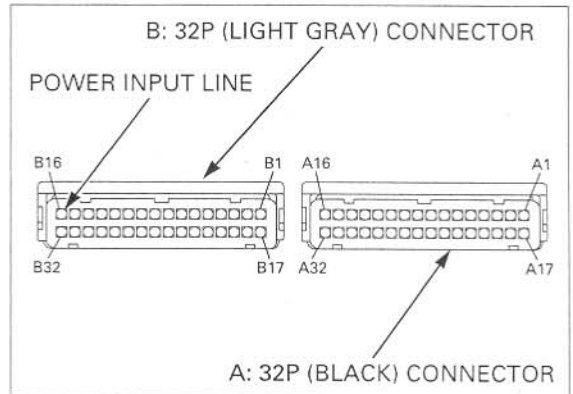

1. Injector System Inspection

Reset the ECM (page 6-9).
Start the engine and check the injector with the HDS.

Is the DTC 12-1 indicated?

YES – GO TO STEP 2.

NO –

- Intermittent failure
- Loose or poor contact on the injector connector

FUEL SYSTEM (Programmed Fuel Injection)

2. Injector Circuit Resistance Inspection

Turn the ignition switch OFF.

Disconnect the ECM 32P connectors and measure the resistance of the ECM 32P connector terminals.

Connection: POWER INPUT LINE – SIGNAL AT ECM

Is there continuity?

YES – GO TO STEP 5.

NO – GO TO STEP 3.

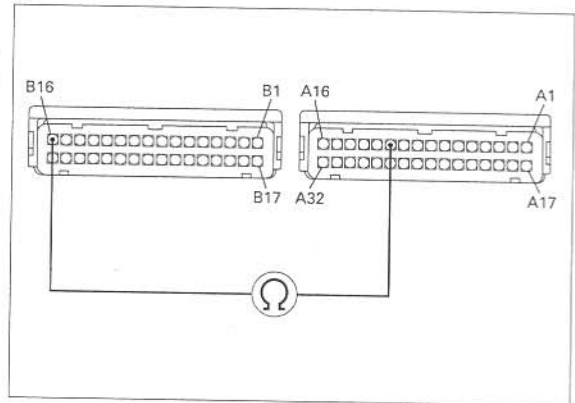

3. Injector Resistance Inspection

Disconnect the primary injector 2P connector and measure the resistance of the primary injector 2P connector terminals.

Is the resistance within 10.5 – 14.5 Ω (20°C/68°F)?

YES – GO TO STEP 4.

NO – Faulty injector

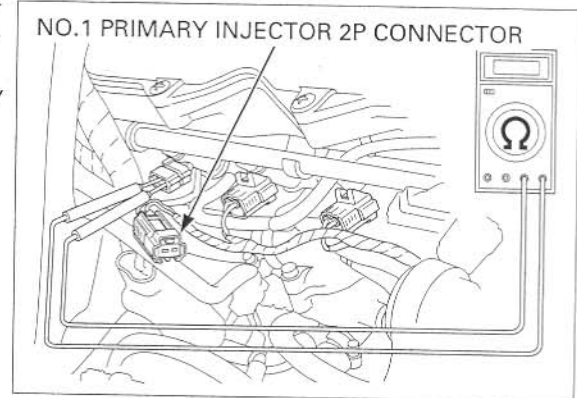

4. Injector Input Voltage Inspection

Turn the ignition switch ON and engine stop switch "Q".

Measure the voltage between the primary injector connector of the wire harness side and ground.

Connection: POWER INPUT LINE (+) – Ground (-)

Is there battery voltage?

YES – Open circuit in SIGNAL LINE wire

NO – Open circuit in POWER INPUT LINE wire

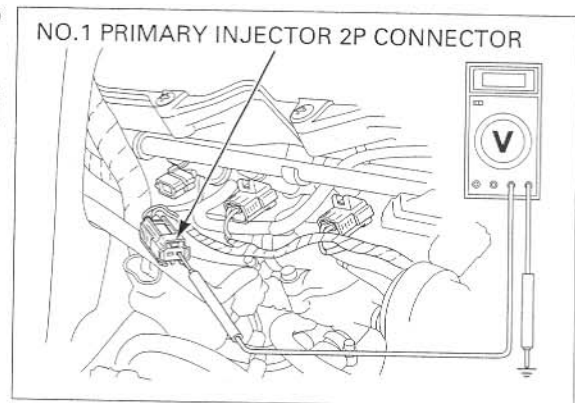

FUEL SYSTEM (Programmed Fuel Injection)

5. Injector Signal Line Short Circuit Inspection

Check for continuity between the ECM 32P connector terminal and ground.

Connection: SIGNAL AT ECM – Ground

Is there continuity?

- YES** – • Short circuit in the SIGNAL LINE wire
• Faulty injector
- NO** – Replace the ECM with a known good one, and recheck

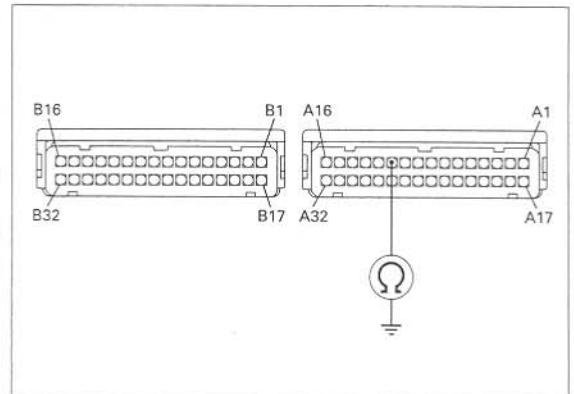

**DTC 13-1
(No.2 PRIMARY INJECTOR)**

(page 6-47)

**DTC 14-1
(No.3 PRIMARY INJECTOR)**

(page 6-47)

**DTC 15-1
(No.4 PRIMARY INJECTOR)**

(page 6-47)

**DTC 16-1
(No.1 SECONDARY INJECTOR)**

(page 6-47)

**DTC 17-1
(No.2 SECONDARY INJECTOR)**

(page 6-47)

**DTC 48-1
(No.3 SECONDARY INJECTOR)**

(page 6-47)

**DTC 49-1
(No.4 SECONDARY INJECTOR)**

(page 6-47)

FUEL SYSTEM (Programmed Fuel Injection)

DTC 18-1 (CAM PULSE GENERATOR)

- Before starting the inspection, check for loose or poor contact on the cam pulse generator connector and recheck the DTC.

1. Cam Pulse Generator Peak Voltage Inspection

Turn the ignition switch OFF.
Disconnect the cam pulse generator 2P connector.

Turn the ignition switch ON and engine stop switch "Q".

Crank the engine with the starter motor, and measure the cam pulse generator peak voltage at the cam pulse generator 2P connector.

Connection: Gray (+) – White/yellow (-)

Is the voltage more than 0.7 V (20 °C/68 °F)?

YES – GO TO STEP 2.

NO – Faulty cam pulse generator

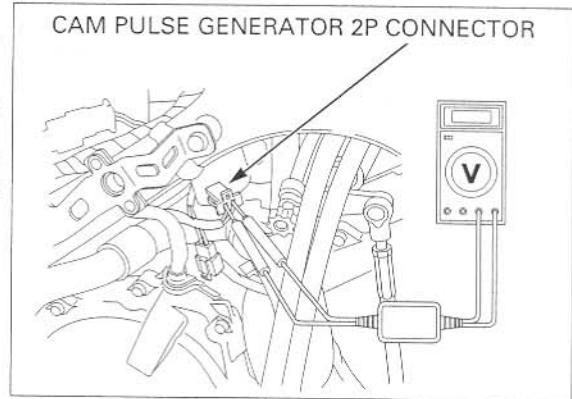

2. Cam Pulse Generator Circuit Inspection

Turn the ignition switch OFF.
Disconnect the ECM 32P connectors.

Check for continuity at the Grey and Green/orange wire between the cam pulse generator 2P connector terminals and the ECM 32P connectors terminals.

Connection: B10 – Gray
A31 – Green/orange

Is there continuity?

YES – Short circuit in the Gray wire

NO – • Open circuit in the Green/orange wire
• Open circuit in the Gray wire

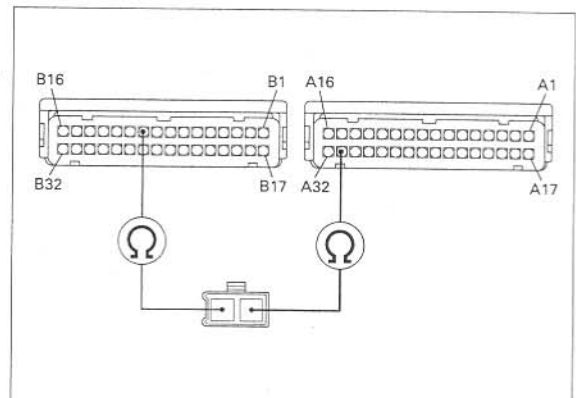

DTC 19-1 (IGNITION PULSE GENERATOR)

- Before starting the inspection, check for loose or poor contact on the ignition pulse generator connector and recheck the DTC.

1. Ignition Pulse Generator Peak Voltage Inspection

Turn the ignition switch OFF.
Lift and support the fuel tank (page 6-61).
Disconnect the ignition pulse generator 2P (Red) connector.

Turn the ignition switch ON and engine stop switch " Ω ".
Crank the engine with the starter motor, and measure the ignition pulse generator peak voltage at the ignition pulse generator 2P (Red) connector.

Connection: Yellow (+) – Yellow/white (-)

Is the voltage more than 0.7 V (20 °C/68 °F)?

YES – GO TO STEP 2.

NO – Faulty ignition pulse generator

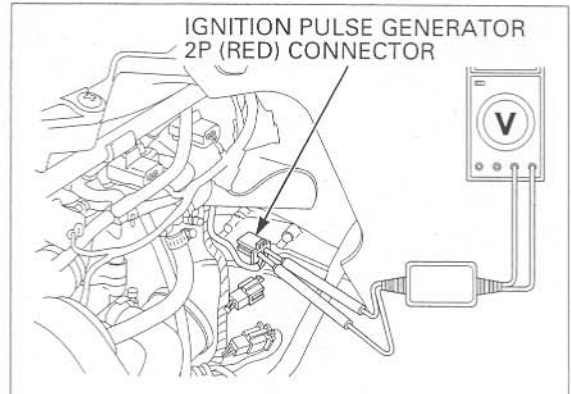

2. Ignition Pulse Generator Circuit Inspection

Turn the ignition switch OFF.
Disconnect the ECM 32P connectors.

Check for continuity at the Yellow and Green/orange wire between the ignition pulse generator 2P (Red) connector terminals and the ECM connector terminals.

Connection: B9 – Yellow
A31 – Yellow/white

Is there continuity?

YES – Short circuit in the Yellow wire

NO – • Open circuit in the Yellow wire
• Open circuit in the Green/orange wire

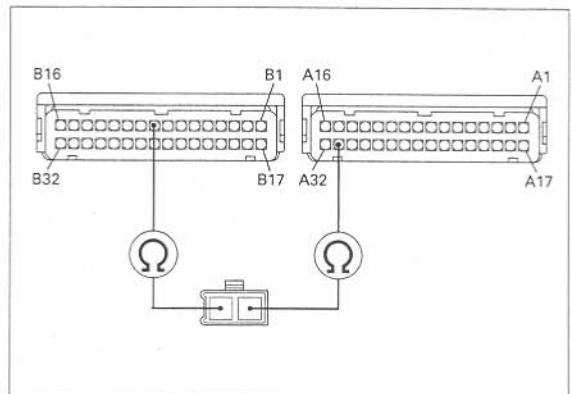

FUEL SYSTEM (Programmed Fuel Injection)

DTC 21-1 (No.1 O₂ SENSOR): California type only

- Before starting the inspection, check for loose or poor contact on the O₂ sensor connector and recheck the DTC.

DTC	O ₂ SEN- SOR	GROUND LINE	SIGNAL LINE	SIGNAL AT ECM
21-1	No.1 O ₂ Sensor	Green/ orange	Black/red	B13
22-1	No.2 O ₂ Sensor	Green/ orange	Black/ orange	B28

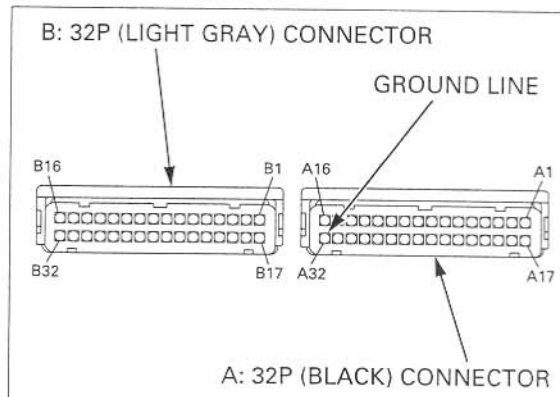

1. O₂ Sensor System Inspection 2

Turn the ignition switch ON and engine stop switch "Ω".

Warm the engine until the coolant temperature is 80 °C (176 °F).

Check the O₂ sensor with the HDS.

Standard: 0.1 – 0.3 V

Is the voltage as specified?

YES – Check the fuel pressure (page 6-56). If the system is correct, GO TO STEP 4.

NO – GO TO STEP 2.

2. O₂ Sensor Open Circuit Inspection

Turn the ignition switch OFF.

Disconnect the O₂ sensor 4P connector and the ECM connectors.

Check the continuity between the ECM connector terminals and the O₂ sensor 4P connector.

Connection: SIGNAL LINE – SIGNAL AT ECM

Is there continuity?

YES – GO TO STEP 3.

- NO** –
- Open circuit in the at SIGNAL LINE wire
 - Open circuit in the GROUND LINE wire

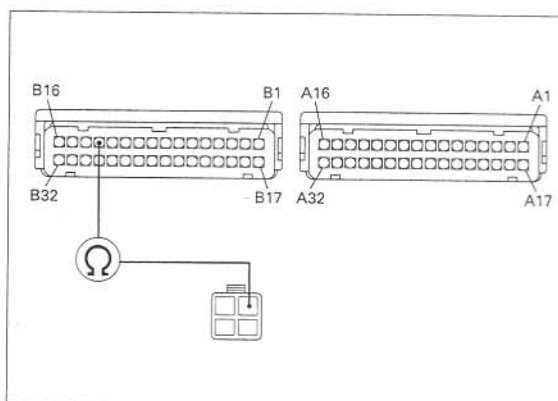

FUEL SYSTEM (Programmed Fuel Injection)

3. O₂ Sensor System Short Circuit Inspection

Connect the O₂ sensor 4P connector and disconnect the ECM connectors.

Check the continuity between the ECM connector terminals and ground.

Connection: SIGNAL AT ECM – Ground

Is there continuity?

YES – Short circuit in the SIGNAL LINE wire

NO – GO TO STEP 4.

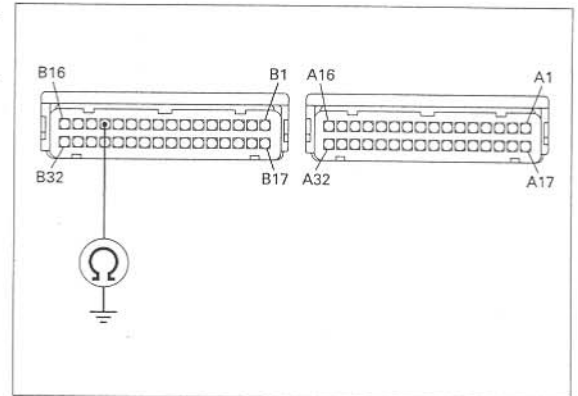

4. O₂ Sensor Inspection

Replace the O₂ sensor with a known good one (page 6-99).

Reset the ECM (page 6-9).

Turn the ignition switch ON and engine stop switch "Q".

Warm the engine until the coolant temperature is 80 °C (176 °C).

Check the voltage at the test harness terminal.

Connection: SIGNAL AT ECM (+) – B17 (-)

Standard: 0.1 – 0.3 V

Is the voltage as specified?

YES – Faulty O₂ sensor

NO – Check the fuel supply system (page 2-2).

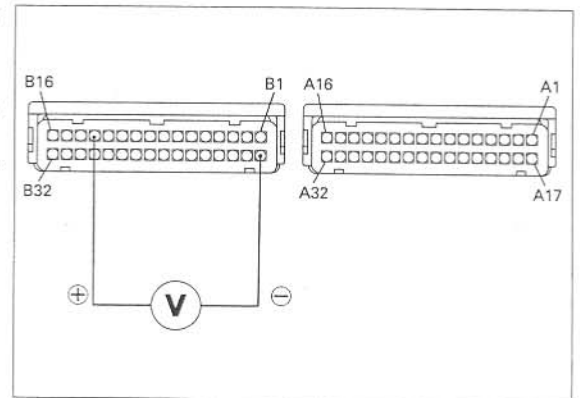

DTC 22-1 (No.2 O₂ SENSOR): California type only

(page 6-52)

FUEL SYSTEM (Programmed Fuel Injection)

DTC 23-1 (No.1 O₂ SENSOR HEATER): California type only

- Before starting the inspection, check for loose or poor contact on the O₂ sensor connector and recheck the DTC.

DTC	O ₂ Sensor	POWER INPUT LINE	SIGNAL LINE	SIGNAL AT ECM
23-1	No.1 O ₂ Sensor	Black/white	White	A10
24-1	No.2 O ₂ Sensor	Black/white	White	A9

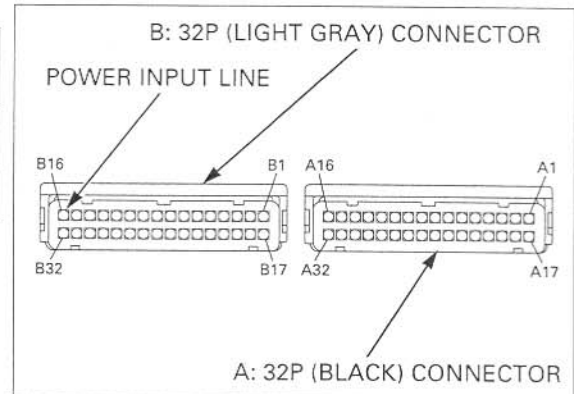

1. O₂ Sensor System Inspection

Reset the ECM (page 6-9).

Start the engine and check the O₂ sensor heater with the HDS.

Is the DTC 23-1 indicated?

YES - GO TO STEP 2.

- NO** -
- Intermittent failure
 - Loose or poor contact on the O₂ sensor connector

2. O₂ Sensor Heater Resistance Inspection

Turn the ignition switch OFF.

Disconnect the O₂ sensor connector and measure the resistance at the sensor side connector white and Green/orange wire terminals.

Connection: White - White

Is the resistance within 10 - 40 Ω (20°C/68°F)?

YES - GO TO STEP 3.

NO - Faulty O₂ sensor

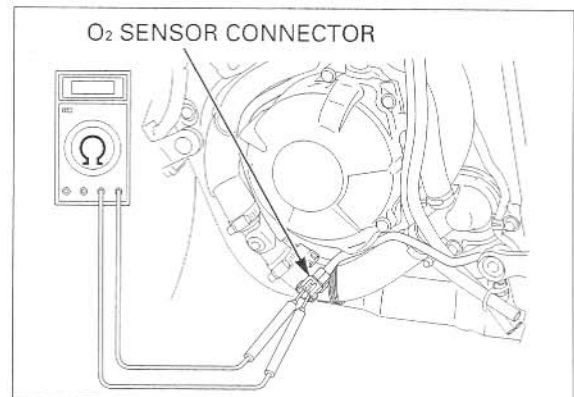

3. O₂ Sensor Heater Open circuit Inspection

Connect the O₂ sensor connector.

Disconnect the ECM 32P connectors and measure the resistance at the ECM terminals.

Connection: POWER INPUT LINE - SIGNAL

Is the resistance within 10 - 40 Ω (20°C/68°F)?

YES - GO TO STEP 4.

- NO** -
- Open circuit in the Black/white wire
 - Open circuit in the SIGNAL LINE wire

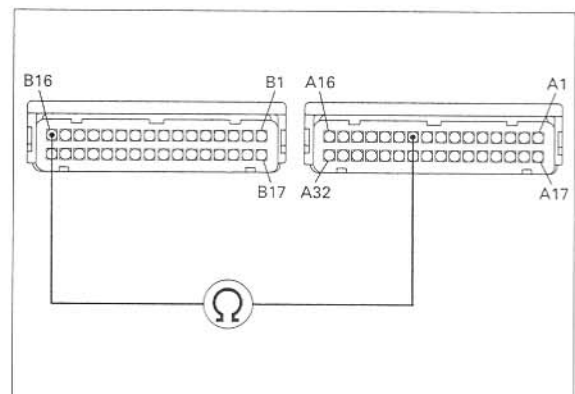

FUEL SYSTEM (Programmed Fuel Injection)

4. O₂ Sensor Heater Short Circuit Inspection 1

Disconnect the O₂ sensor connector.
Check for continuity between the SIGNAL LINE wire terminal at ECM 32P connectors and ground.

Connection: SIGNAL AT ECM – Ground

Is there continuity?

YES – Short circuit in the SIGNAL LINE wire

NO – GO TO STEP 5.

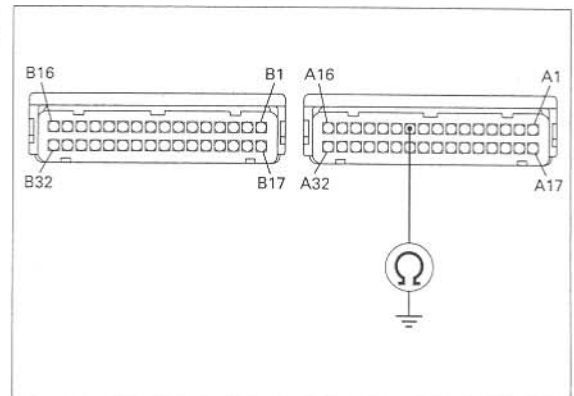

5. O₂ Sensor Heater Short Circuit Inspection 2

Check for continuity between the O₂ sensor heater connector terminal and ground.

Connection: White – Ground

Is there continuity?

YES – Faulty O₂ sensor

NO – Replace the ECM with a known good one, and recheck.

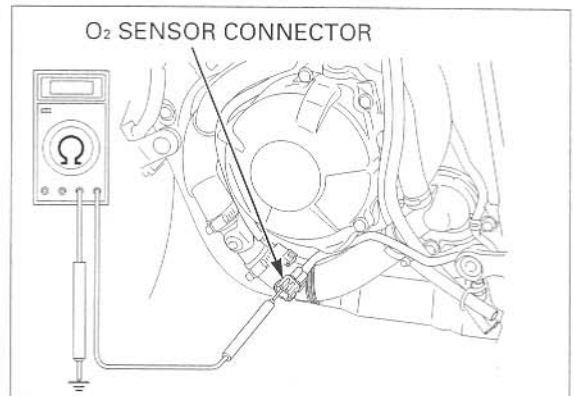

DTC 24-1 (No.2 O₂ SENSOR HEATER): California type only

(page 6-54)

DTC 33-1 (E²-PROM)

1. Recheck DTC

Reset the ECM (page 6-9).
Turn the ignition switch ON and engine stop switch " Ω ".

Recheck the ECM E²-PROM

Is the DTC 33-1 indicated?

YES – Replace the ECM with a known good one, and recheck.

NO – Intermittent failure

FUEL SYSTEM (Programmed Fuel Injection)

FUEL LINE INSPECTION

FUEL PRESSURE INSPECTION

- Before disconnecting fuel hoses, release the fuel pressure by loosening the fuel feed hose banjo bolt at the fuel tank.
- Failure to release the fuel pressure could result in fuel spilling onto painted or plastic parts, which will be damaged.
- Always replace the sealing washers when the fuel feed hose banjo bolt is removed or loosened.

Remove the seat (page 3-4).

Disconnect the battery negative cable from the battery terminal.

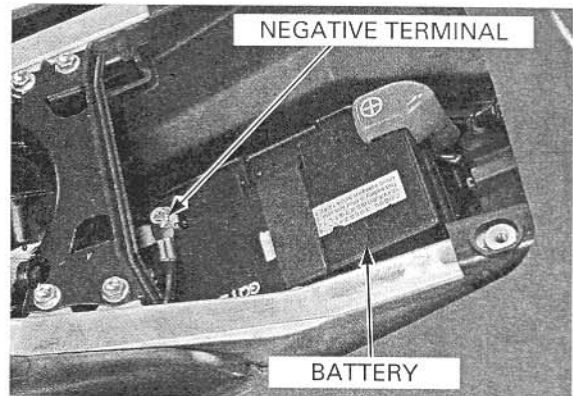

Lift and support the fuel tank (page 6-61).

Cover the fuel hose banjo bolt with a rag or shop towel.

Slowly loosen the fuel hose banjo bolt and catch the remaining fuel using an approved gasoline container.

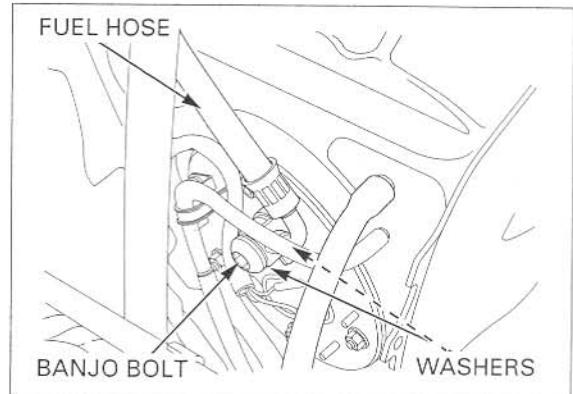

Remove the fuel hose banjo bolt and attach the fuel pressure gauge with the following Honda genuine parts.

Banjo bolt, 12 mm
Part No. 90008-PD6-010
Sealing washer, 12 mm
Part No. 90428-PD6-003
Sealing washer, 6 mm
Part No. 90430-PD-003

TOOL:

Fuel pressure gauge, 100 psi
07406-0040003 or
07406-0040002 or
07406-004000A
(U.S.A. only)

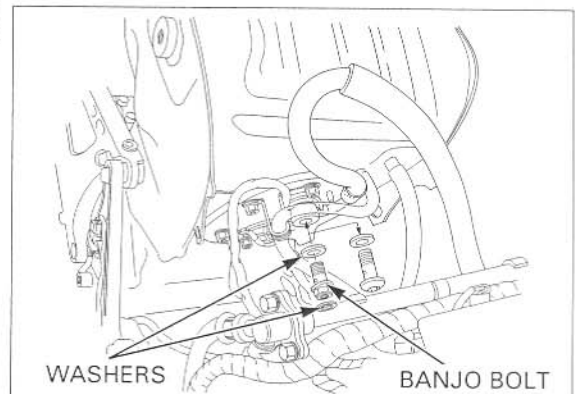

FUEL SYSTEM (Programmed Fuel Injection)

Connect the battery negative cable.
Start the engine.
Measure the fuel pressure at idle speed.

IDLE SPEED: $1,300 \pm 100$ rpm
STANDARD: 343 kPa (3.5 kgf/cm², 50 psi)

If the fuel pressure is higher than specified, replacement the fuel pump unit (page 6-59).

If the fuel pressure is lower than specified, inspect the following:

- Fuel line leaking
- Fuel strainer (page 6-60)

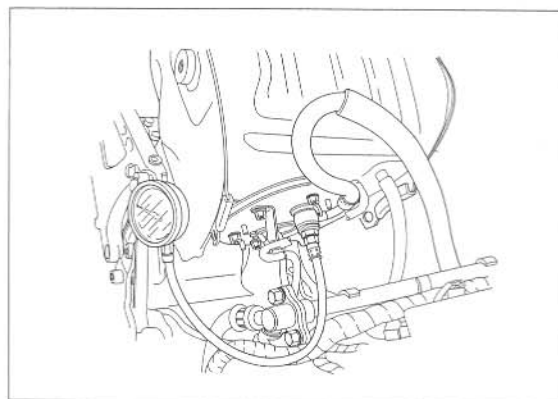

Always replace the sealing washer when the fuel feed hose banjo bolt is removed or loosened.

After inspection, remove the banjo bolt and reinstall and tighten the original fuel hose banjo bolt using new sealing washers.

TORQUE: 22 N·m (2.2 kgf·m, 16 lbf·ft)

Remove the suitable support and close the fuel tank (page 6-63).

Install the removed parts in the reverse order of removal.

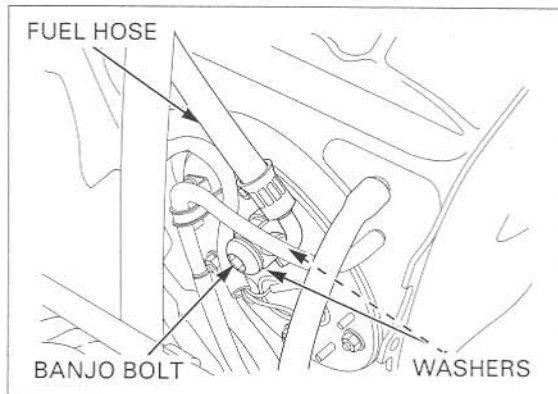

FUEL FLOW INSPECTION

Remove the following:

- Lower cowls (page 3-6)
- Middle cowls (page 3-7)

Disconnect the fuel cut-off relay connector.

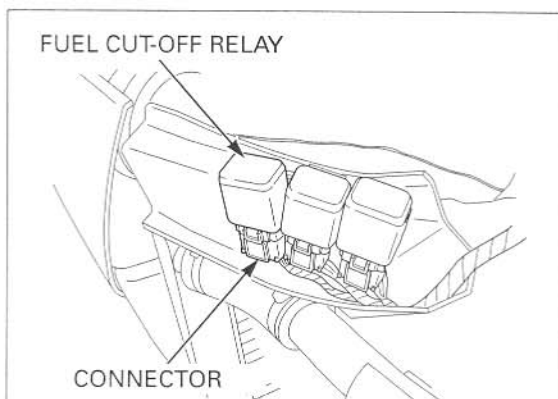

Jump the Brown and Black/white wire terminals of the wire harness side using a jumper wire.

- Place an approved gasoline container and drain the gasoline.
- Wipe off spilled out gasoline.

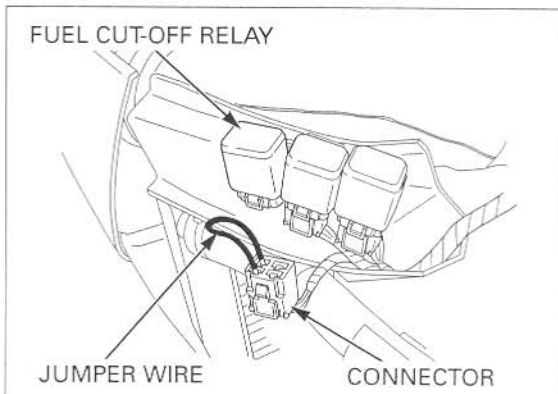

FUEL SYSTEM (Programmed Fuel Injection)

Do not apply excessive force or the fuel rail may be damaged.

Hold the fuel pipe nut and remove the fuel hose sealing nut and sealing washers, then disconnect the fuel hose.

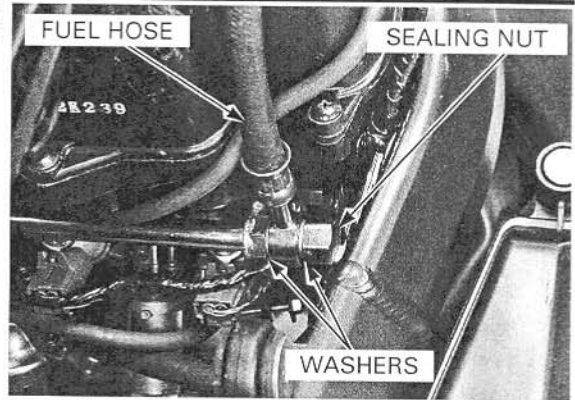

Turn the ignition switch ON for 10 seconds. Measure the amount of fuel flow.

Amount of fuel flow:

189 cm³ (6.4 US oz, 6.7 Imp oz) minimum /10 seconds at 12 V

If the fuel flow is less than specified, inspect the following:

- Pinched or clogged fuel hose
- Fuel pump unit (page 6-58)

After inspection, install a new sealing washers, fuel hose sealing nut and connect the fuel hose.

TORQUE:

Fuel hose sealing nut: 22 N·m (2.2 kgf·m, 16 lbf·ft)

Start the engine and check for leaks.

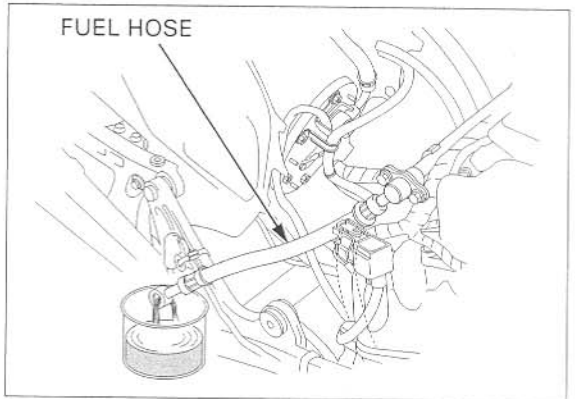

FUEL PUMP UNIT

INSPECTION

Turn the ignition switch ON and confirm that the fuel pump operates for a few seconds.

If the fuel pump does not operate, inspect as follow:

Lift and support the fuel tank (page 6-61).

Disconnect the fuel pump unit 3P (Black) connector.

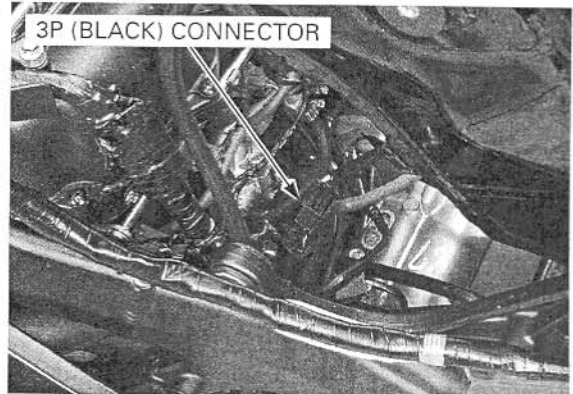

FUEL SYSTEM (Programmed Fuel Injection)

Turn the ignition switch ON and measure the voltage between the terminals.

Connection: Brown (+) – Green (-)

There should be battery voltage for a few seconds.

If there is battery voltage a few seconds, replace the fuel pump unit.

If there is no battery voltage, inspect the following:

- Main fuse 30A
- Sub fuse 10A
- Engine stop switch (page 20-20)
- Fuel cut-off relay (page 6-60)
- Engine stop relay (page 6-94)
- Bank angle sensor (page 6-93)
- ECM (page 6-95)

REMOVAL

- Before disconnecting the fuel line, release the fuel pressure by loosening the fuel hose banjo bolt at the fuel tank.
- Failure to release the fuel pressure could result in fuel spilling onto painted or plastic parts, which will be damaged.
- Always replace the sealing washers when the fuel hose banjo bolt is removed or loosened.

Remove the fuel tank (page 6-61).

Remove the fuel pump unit mounting nuts and clamp.

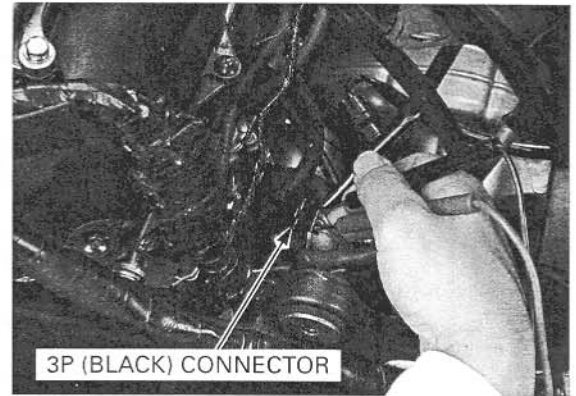

Remove the fuel pump unit and packing.

Be careful not to damage the pump wire and fuel level gauge.

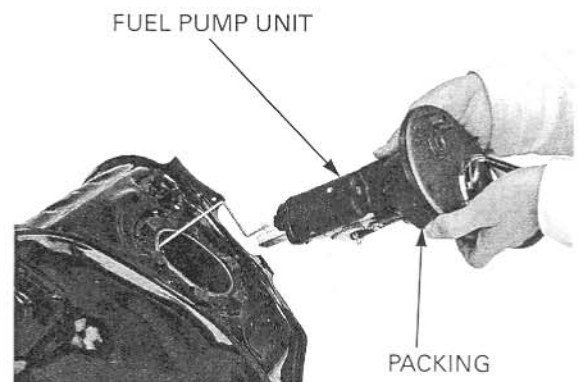
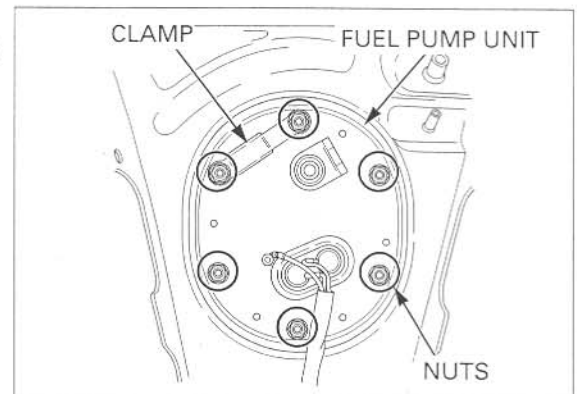

FUEL SYSTEM (Programmed Fuel Injection)

INSPECTION

Check the fuel pump unit for wear or damage, replace it if necessary.

Clean the fuel strainer screen with non-flammable or high flash point solvent.

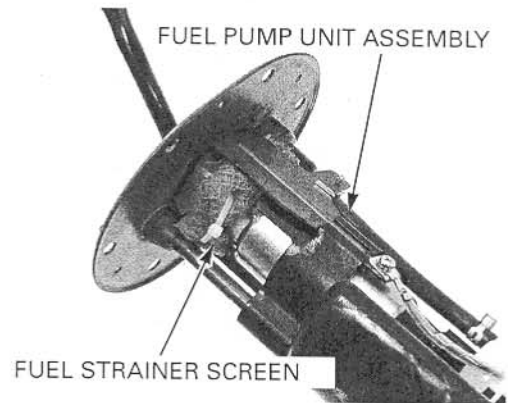

INSTALLATION

Always replace the packing with a new one.

Be careful not to damage the pump wire and fuel level gauge.

Place a new packing onto the fuel pump unit.

Install the fuel pump unit into the fuel tank.

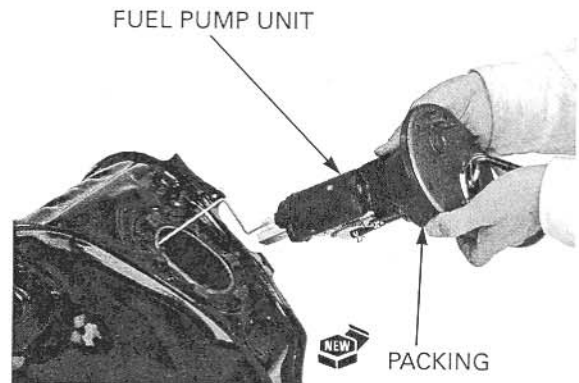

Install the clamp and tighten the fuel pump mounting nuts in the specified sequence as shown.

TORQUE: 12 N·m (1.2 kgf·m, 9 lbf·ft)

Install the fuel tank (page 6-62).

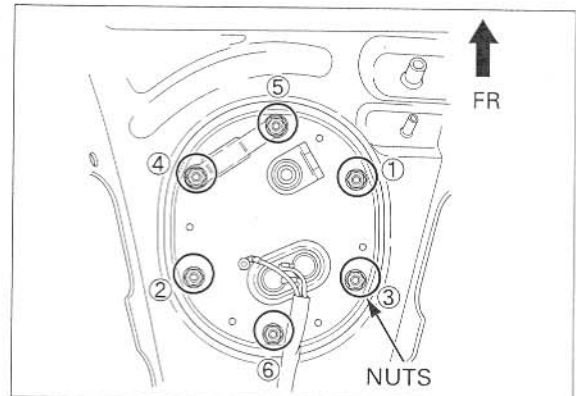

FUEL CUT-OFF RELAY

INSPECTION

Remove the following:

- Lower cowls (page 3-6)
- Middle cowls (page 3-7)

Disconnect the fuel cut-off relay 4P connector, remove the fuel cut-off relay.

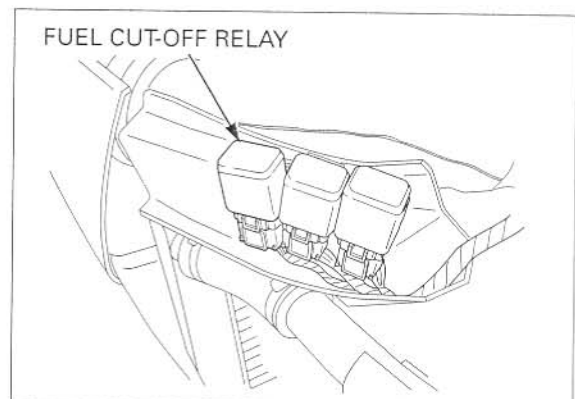

FUEL SYSTEM (Programmed Fuel Injection)

Connect the ohmmeter to the fuel cut-off relay connector terminals.

Connection: A - B

Connect the 12V battery to the following fuel cut-off relay connector terminals.

Connection: C (+) - D (-)

There should be continuity only when the 12V battery is connected. If there is no continuity when the 12V battery is connected, replace the fuel cut-off relay.

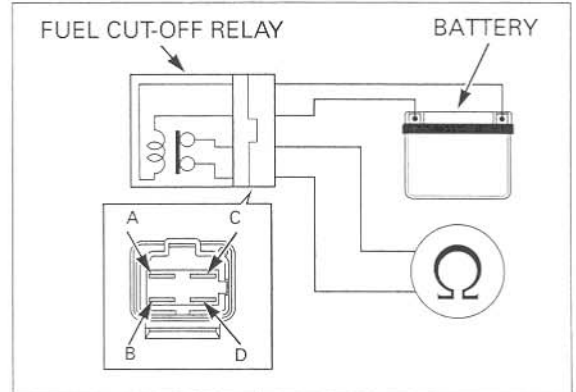

FUEL TANK

REMOVAL

Remove the fuel tank cover (page 3-15).

Remove the fuel tank mounting bolts.

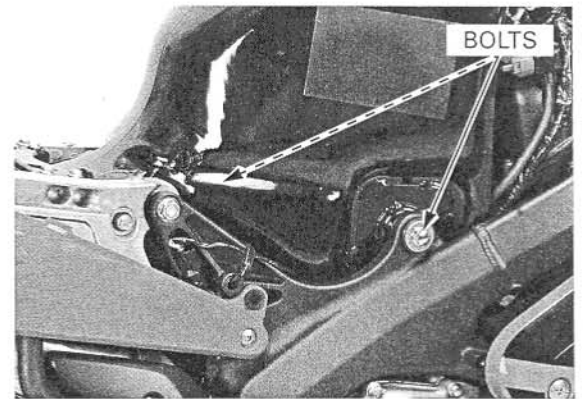

Lift the fuel tank and support it using a suitable support.

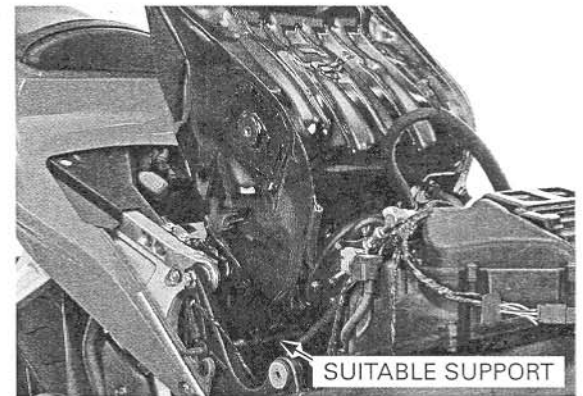

Disconnect the fuel pump unit 3P (Black) connector.

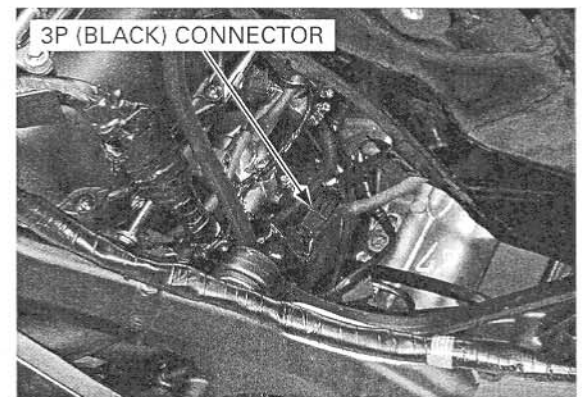

FUEL SYSTEM (Programmed Fuel Injection)

Disconnect the fuel tank air vent and overflow hoses.

Cover the fuel hose banjo bolt with a rag or shop towel.

Slowly loosen the banjo bolt and catch the remaining fuel using a approved gasoline container.

Remove the fuel hose banjo bolt and sealing washers, then disconnect the fuel hose.

- Before disconnecting fuel hoses, release the fuel pressure by loosening the fuel hose banjo bolt at the fuel tank.
- Failure to release the fuel pressure could result in fuel spilling onto painted or plastic parts, which will be damaged.
- Always replace the sealing washers when the fuel hose banjo bolt is removed or loosened.

Remove the fuel tank pivot bolts, collars and fuel tank.

Refer to procedures for fuel pump unit removal (page 6-59).

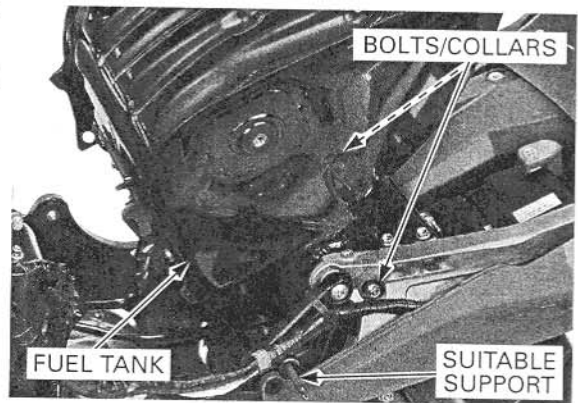
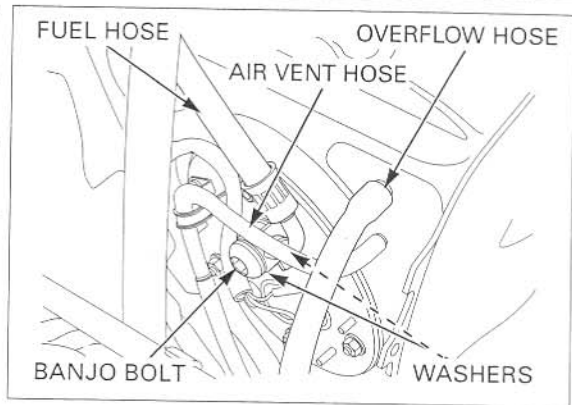

INSTALLATION

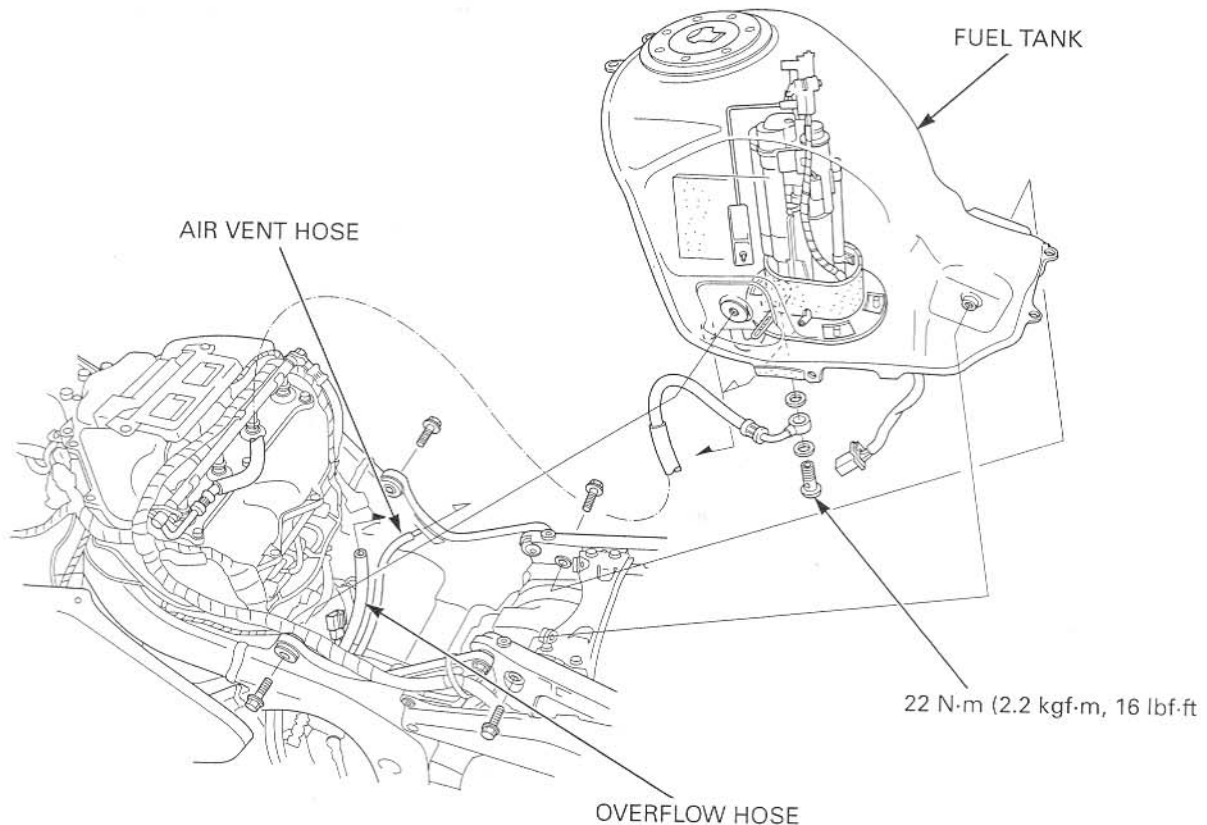

FUEL SYSTEM (Programmed Fuel Injection)

Install the fuel tank, collars and pivot bolts into the frame and tighten the bolts securely.

Support the fuel tank using a suitable support.

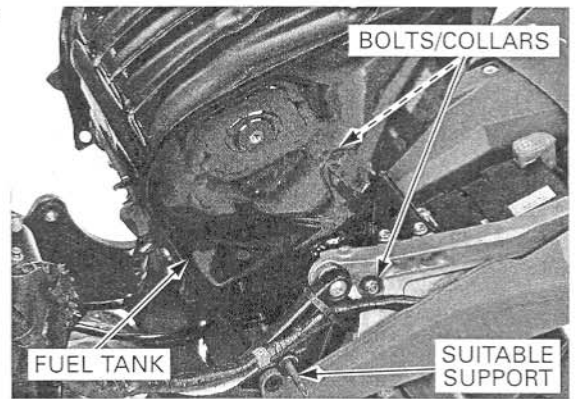

Align the fuel hose eyelet joint with the stopper on the fuel pump mounting stay.

Install the new sealing washers and tighten the fuel hose banjo bolt to the specified torque.

TORQUE: 22 N·m (2.2 kgf·m, 16 lbf·ft)

Route the hoses properly (page 1-22).

Connect the air vent and overflow hoses to the fuel tank.

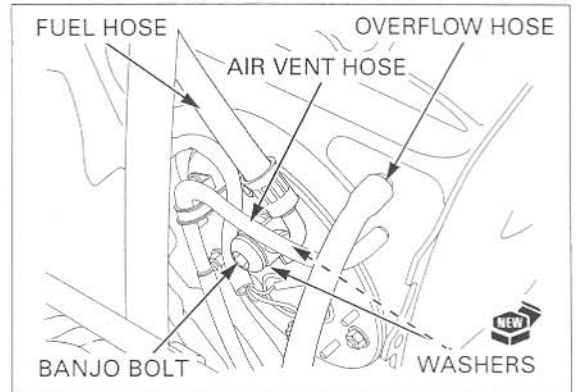

Connect the fuel pump unit 3P (Black) connector.

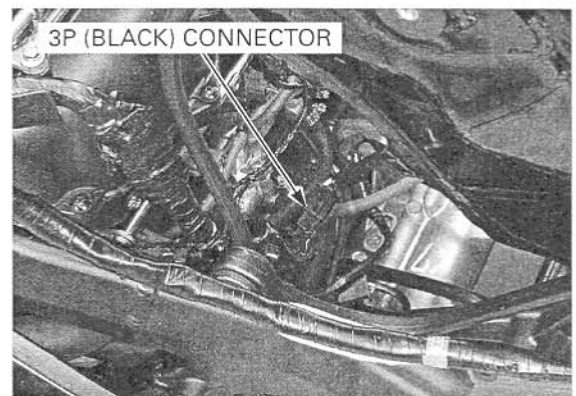

Be careful not to damage the wire harness, fuel feed hose, overflow hose and air vent hose.

Remove the suitable support and close the fuel tank on the frame.

Route the harness, wires and hoses properly (page 1-22).

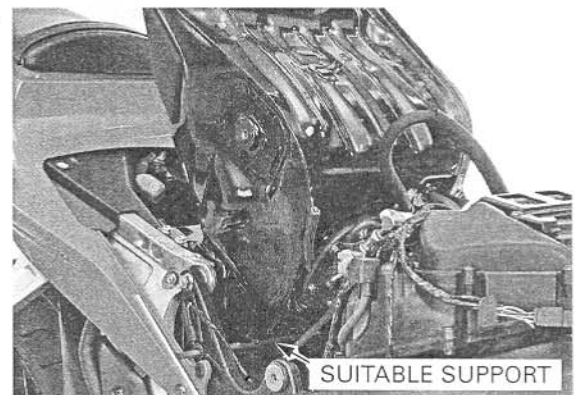

FUEL SYSTEM (Programmed Fuel Injection)

Install and tighten the mounting bolts and wire clamp.

Install the fuel tank cover (page 3-15).

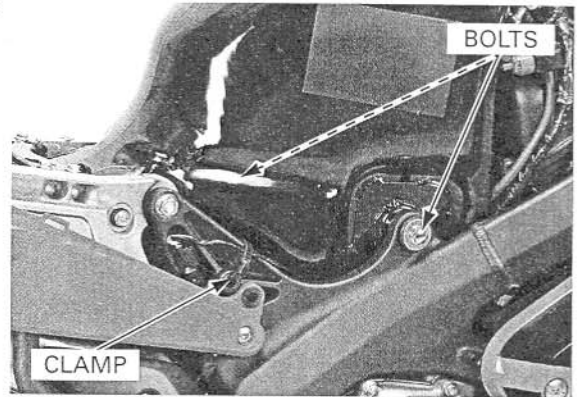

AIR CLEANER HOUSING

REMOVAL

Remove the following:

- Fuel tank (page 6-61)
- ECM (page 6-94)
- Air cleaner cover (page 4-6)

Disconnect the secondary injector connectors.

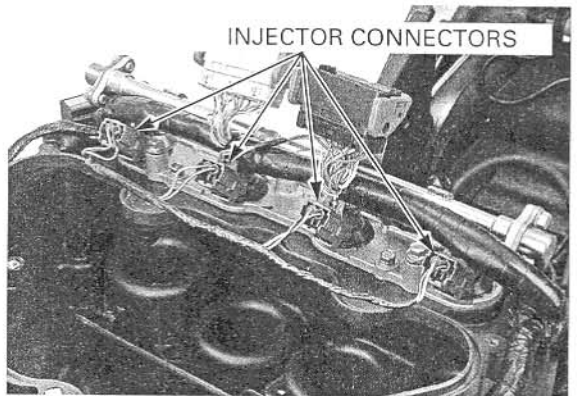

Remove the five bolts and secondary injector mounting bracket from the air cleaner housing.

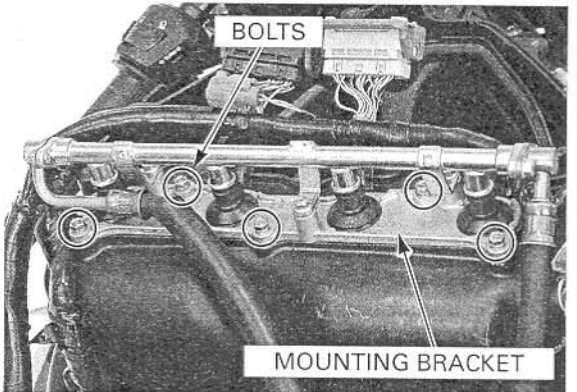

Disconnect the MAP sensor connector and vacuum hose.

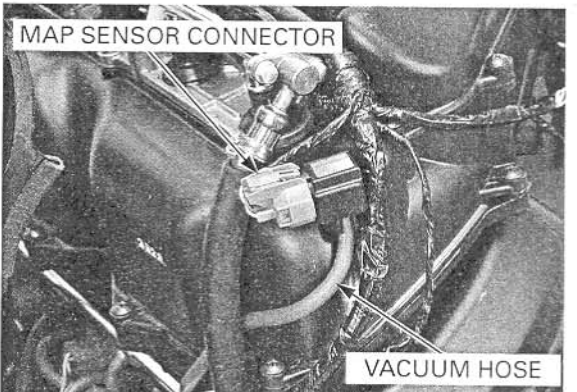

FUEL SYSTEM (Programmed Fuel Injection)

Remove the eight screws and upper air cleaner housing.

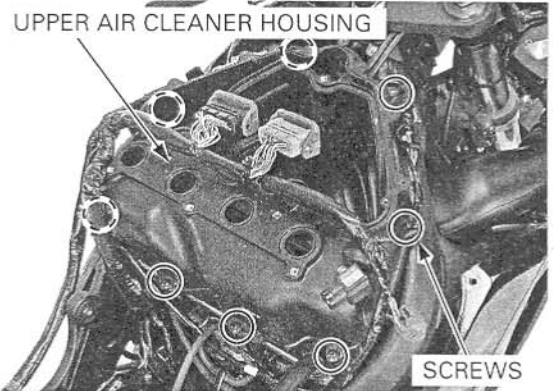

Remove the air funnel/air cleaner housing mounting screws, then remove the air funnels.

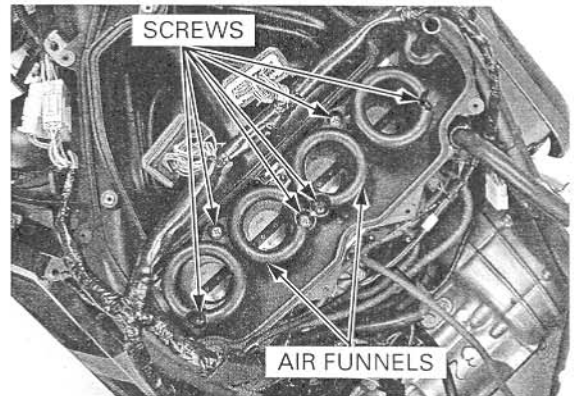

Disconnect the PAIR air suction hose from the air cleaner housing.

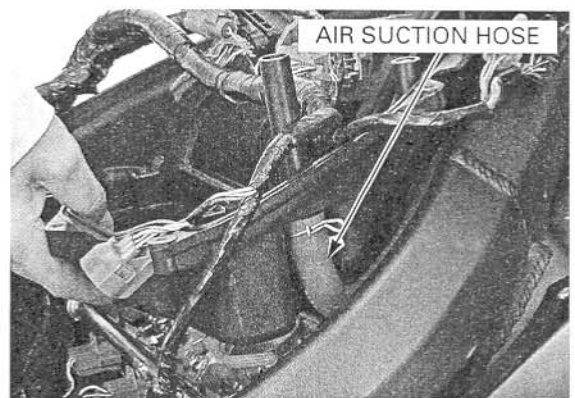

Disconnect the crankcase breather hose from the air cleaner housing.

Remove the wire band clamp from the air cleaner housing.

Remove the air cleaner housing.

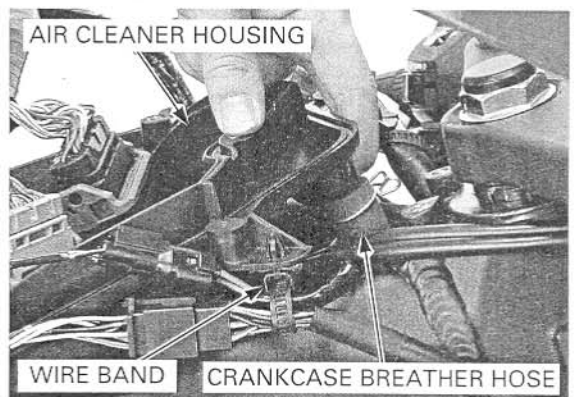

FUEL SYSTEM (Programmed Fuel Injection)

INSTALLATION

Connect the crankcase breather hose to the air cleaner housing.

Install the wire band and secure the wires.

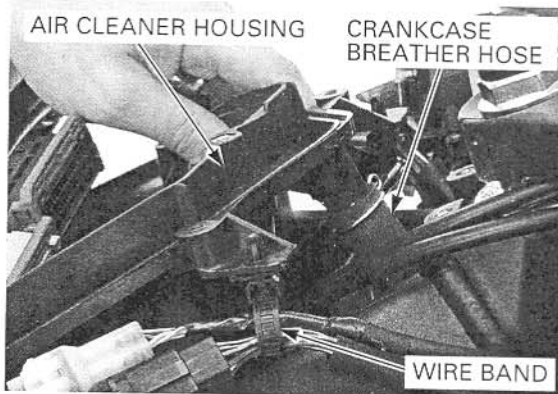

Connect the PAIR air suction hose to the air cleaner housing.

Install the air cleaner housing onto the throttle body.

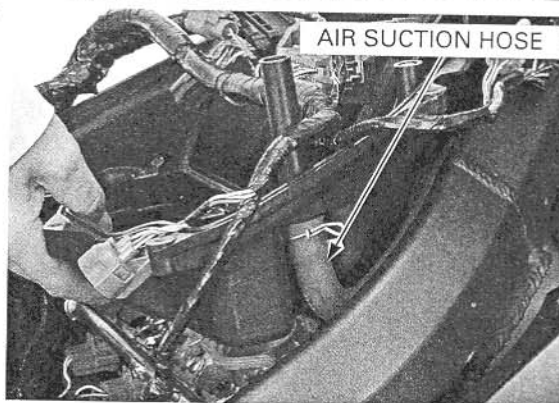

Install the air funnels in their proper locations.
Install and tighten the air funnel/air cleaner housing mounting screws.

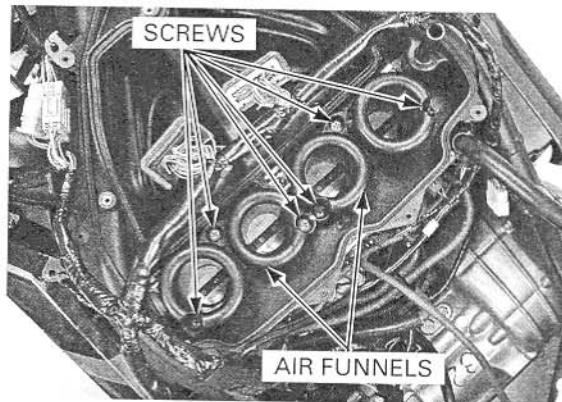

Install the upper air cleaner housing and eight screws.
Tighten the screws securely.

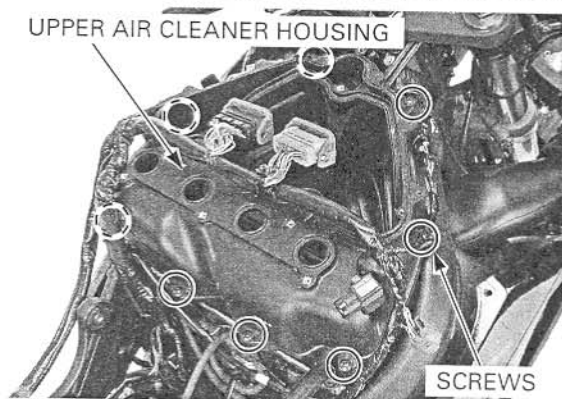

FUEL SYSTEM (Programmed Fuel Injection)

Connect the MAP sensor connector and vacuum hose.

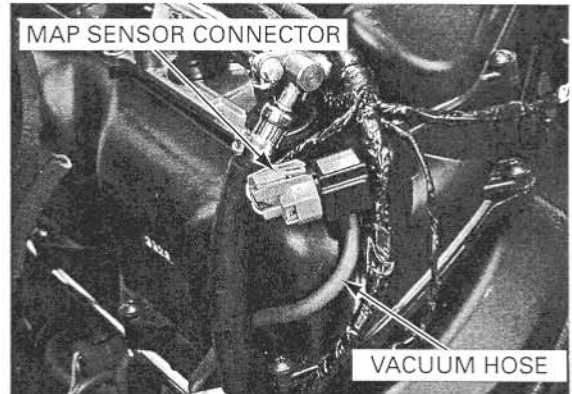

Install the secondary injector mounting bracket onto the air cleaner housing. Tighten the bolts to the specified torque.

TORQUE: 5.4 N·m (0.55 kgf·m, 4 lbf·ft)

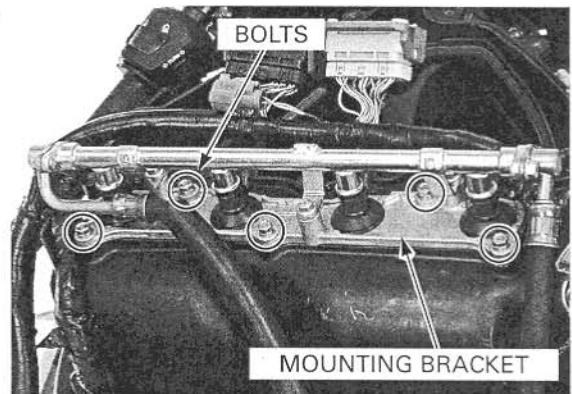

Connect the secondary injector connectors. Install the removed parts in the reverse order of removal.

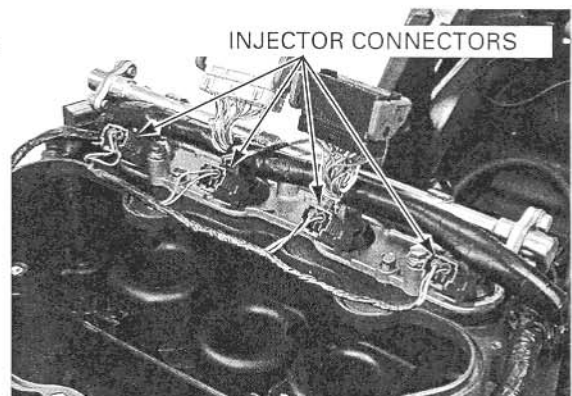

SECONDARY INJECTOR

INSPECTION

Start the engine and let it idle. Confirm the injector operating sounds with a sounding rod or stethoscope.

NOTE:

The secondary injectors operate with following conditions.

- Engine speed is over 5,500 rpm
- Throttle opening is over 50°

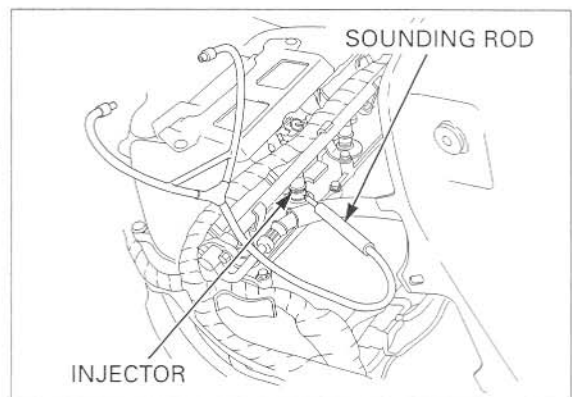

FUEL SYSTEM (Programmed Fuel Injection)

REMOVAL

- Before disconnecting the fuel line, release the fuel pressure by loosening the fuel hose banjo bolt.
- Failure to release the fuel pressure could result in fuel spilling onto painted or plastic parts, which will be damaged.
- Always replace the sealing washer when the fuel hose banjo bolt is removed or loosened.

Remove the following:

- Fuel tank (page 6-61)
- ECM (page 6-94)
- Air cleaner cover (page 4-6)

Disconnect the secondary injector connectors.

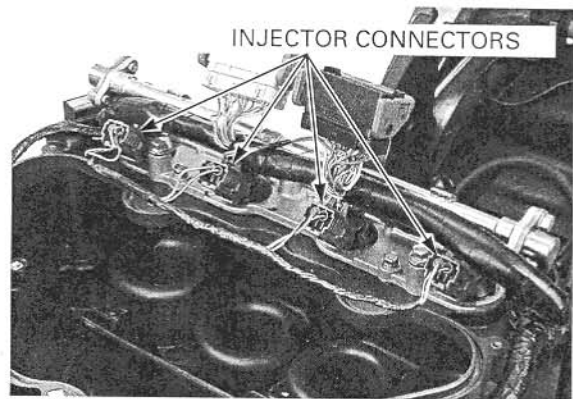

Do not apply excessive force the fuel rail.

Hold the fuel rail nut and remove the fuel hose sealing nut and sealing washers, then disconnect the fuel hose.

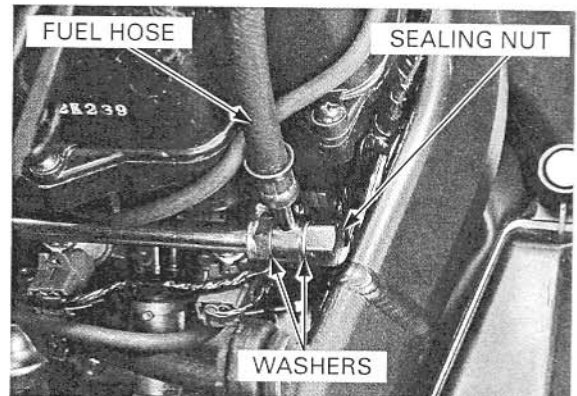

Remove the five bolts and secondary injector mounting bracket from the air cleaner housing.

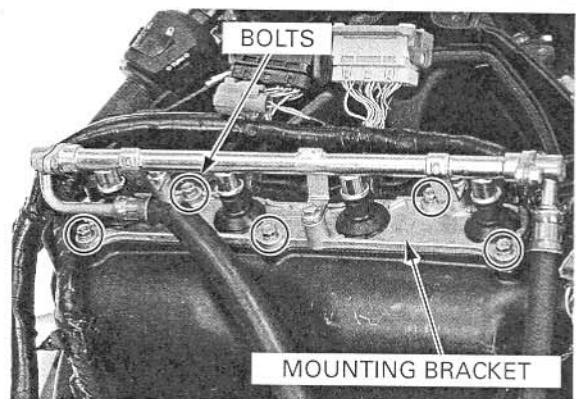

FUEL SYSTEM (Programmed Fuel Injection)

Remove the bolts and fuel rail/secondary injector assembly from the mounting bracket.

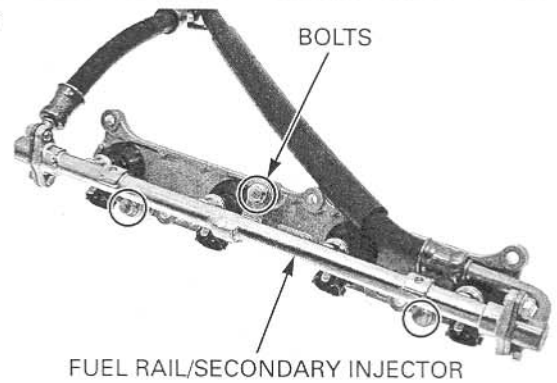

Remove the injectors from the fuel rail.

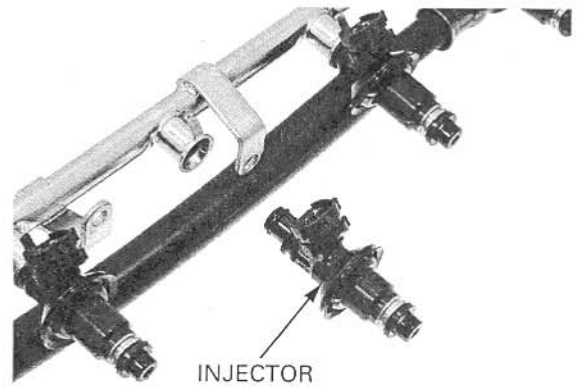

Remove the O-ring, seal ring, cushion ring and dust seal.



Remove the two bolts, fuel hose and O-ring.

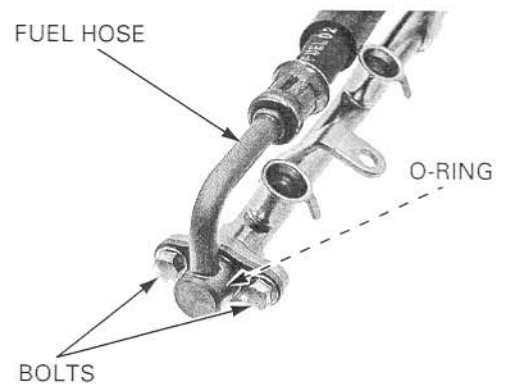

FUEL SYSTEM (Programmed Fuel Injection)

INSTALLATION

Apply oil to new O-ring and install it into the fuel rail.

Install the fuel hose into the fuel rail.

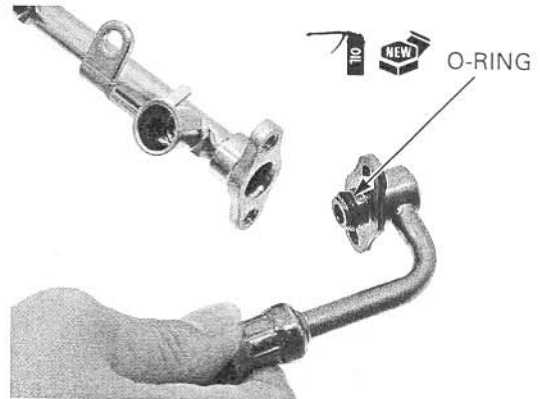

Tighten the bolts securely.

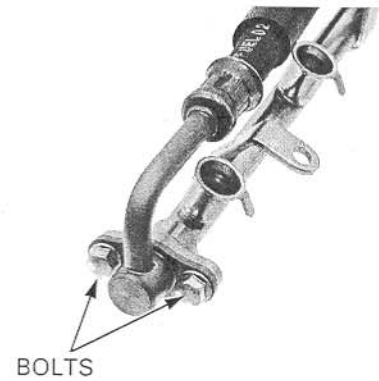

Apply oil to a new O-ring.

Replace the seal ring, cushion ring and O-ring with new ones as a set.

Install the new seal ring, cushion ring and O-ring, being careful not to damage the O-ring.

Check the dust seal for wear or damage, replace it if necessary.

Install the dust seal.



Install the fuel injectors into the fuel rail, being careful not to damage the O-ring and cushion ring.

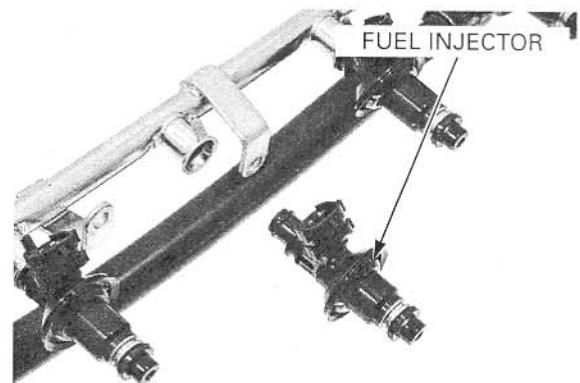

FUEL SYSTEM (Programmed Fuel Injection)

Install the fuel rail/secondary injector assembly onto the mounting bracket, being careful not to damage the seal rings and tighten the bolts to the specified torque.

TORQUE: 9.8 N·m (1.0 kgf·m, 7 lbf·ft)

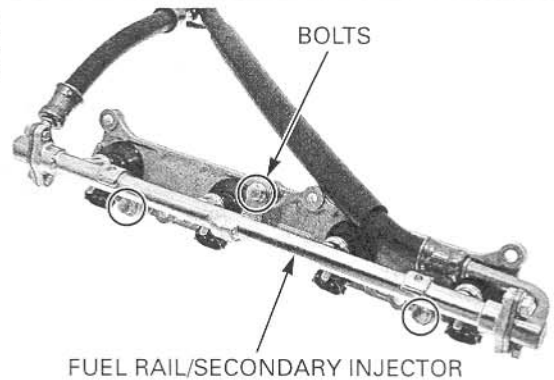

Install the secondary injector mounting bracket onto the air cleaner housing and tighten the bolts to the specified torque.

TORQUE: 5.4 N·m (0.55 kgf·m, 4 lbf·ft)

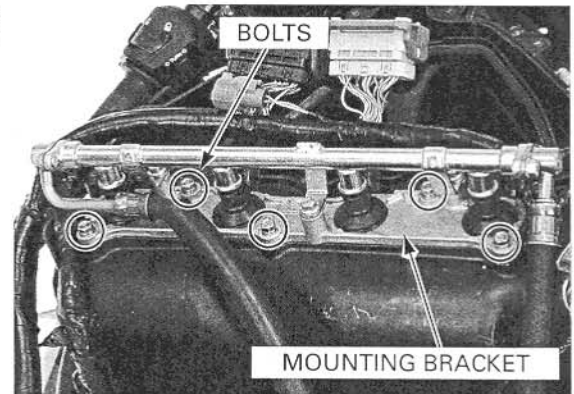

Connect the fuel hose to the fuel rail with new sealing washers. Install and tighten the sealing nut to the specified torque.

TORQUE: 22 N·m (2.2 kgf·m, 16 lbf·ft)

- Do not apply excessive force to the fuel rail.
- Always hold the fuel rail nut while tightening the fuel hose sealing nut.

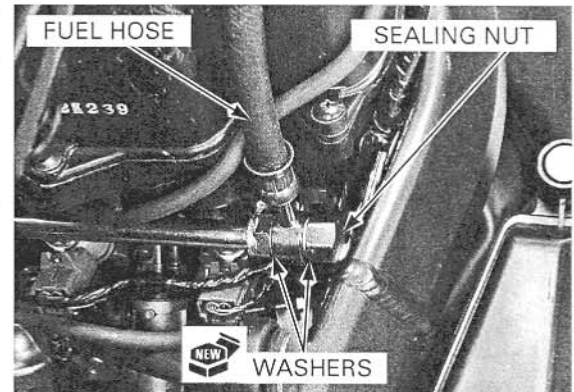

Connect the secondary injector connectors.

Install the removed parts in the reverse order of removal.

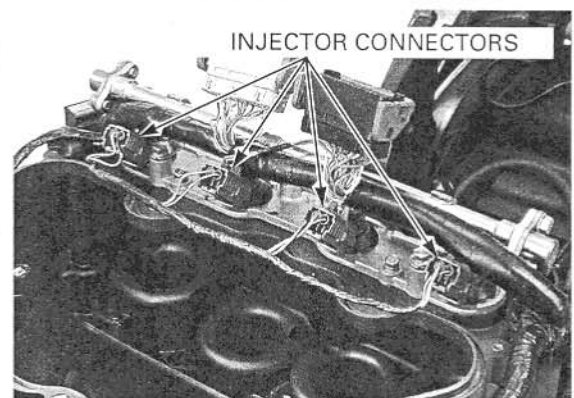

FUEL SYSTEM (Programmed Fuel Injection)

THROTTLE BODY

REMOVAL

- Before disconnecting the fuel line, release the fuel pressure by loosening the fuel hose banjo bolt.
- Failure to release the fuel pressure could result in fuel spilling onto painted or plastic parts, which will be damaged.
- Always replace the sealing washer when the fuel hose banjo bolt is removed or loosened.

Drain the coolant from the cooling system (page 7-6).

Remove the following:

- Lower cowls (page 3-6)
- Middle cowls (page 3-7)
- Fuel tank (page 6-61)
- Air cleaner housing (page 6-64)

Release the throttle stop screw knob from the clamp.

California type only: Disconnect the EVAP purge control solenoid valve hose from the 5-way joint.

Disconnect the primary injector connectors.
Disconnect the TP sensor connector.

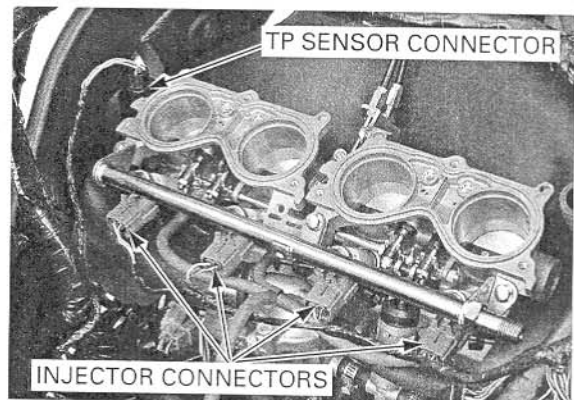
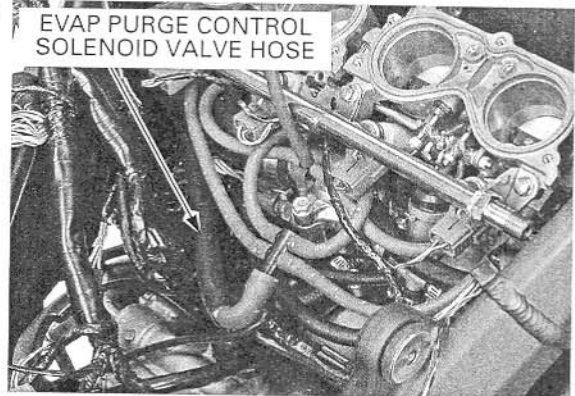
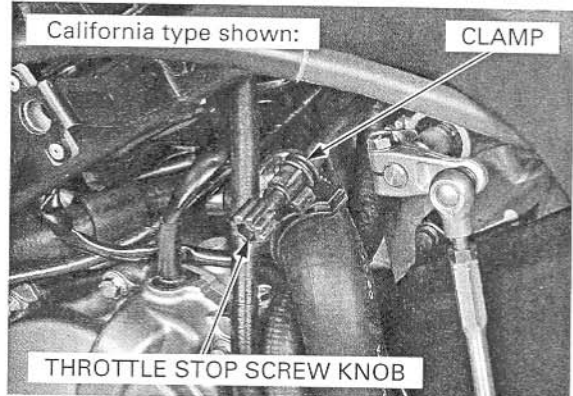

FUEL SYSTEM (Programmed Fuel Injection)

Loosen the hose clamp screws and disconnect the fast idle wax unit water hoses from the wax unit.

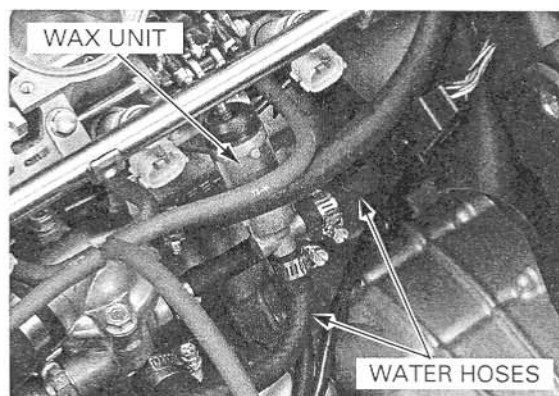

Remove the bolt, stay and tool box from the frame.

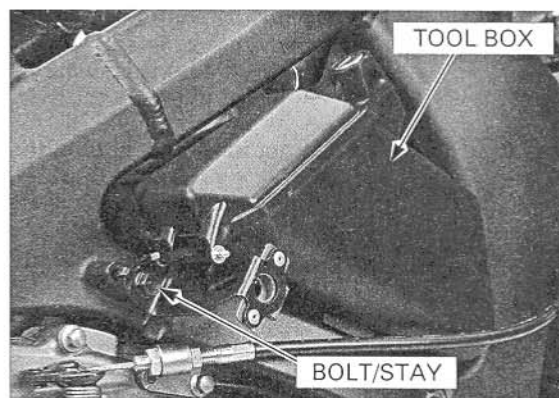

Do not hold the fuel rail on the throttle body to remove the throttle body, or it may be damaged.

Loosen the engine side insulator band screws using a long type phillips screwdriver.

Remove the throttle body from the cylinder head.

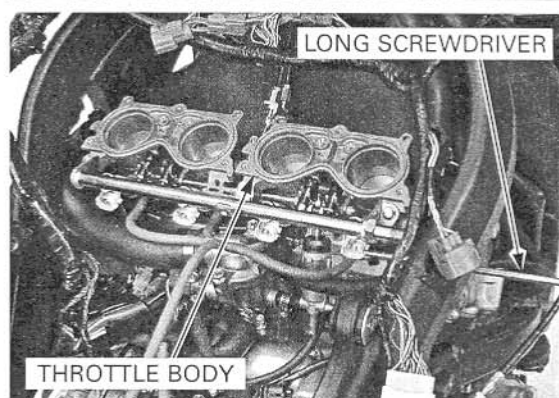

Do not snap the throttle valve from fully open to fully closed after the throttle cable has been removed. It may cause incorrect idle operation.

Loosen the lock nuts and disconnect the throttle cable ends from the throttle drum.

- Seal the cylinder head intake ports with tape or a clean cloth to keep dirt and debris from entering the intake ports after the throttle body has been removed. If debris is allowed to enter the ports the engine may be damaged.

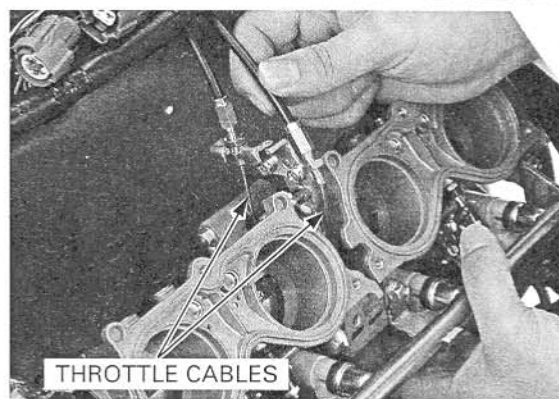

FUEL SYSTEM (Programmed Fuel Injection)

Loosen the insulator band screws and remove the insulators from the throttle body.

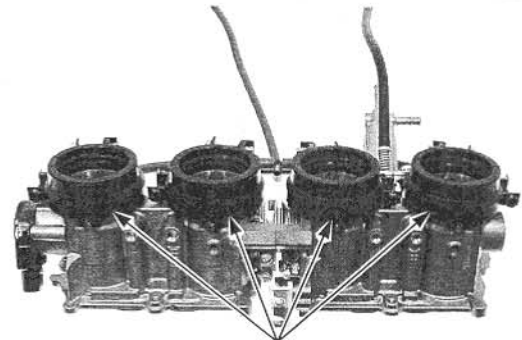

INSULATORS

- Do not damage the throttle body. It may cause incorrect throttle and idle valve synchronization.
- The throttle body is factory pre-set. Do not disassemble in a way other than shown in this manual.
- Do not loosen or tighten the white painted bolts and screws of the throttle body. Loosening or tightening them can cause throttle and idle valve synchronization failure.

TOP VIEW:

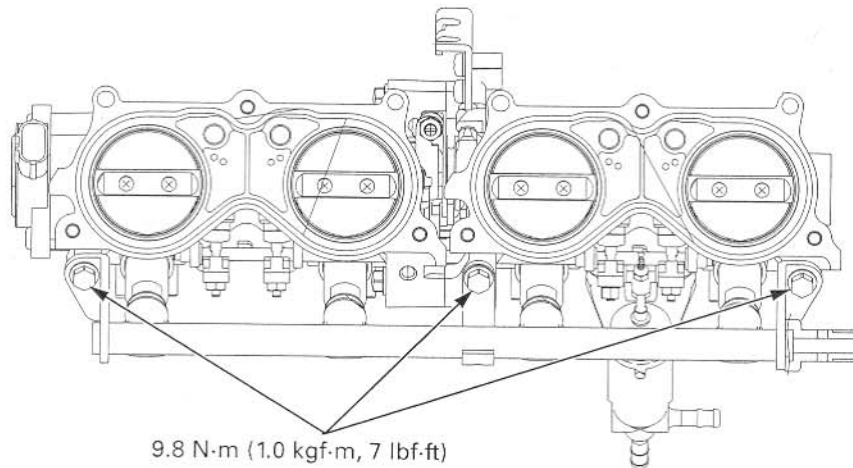

REAR VIEW:

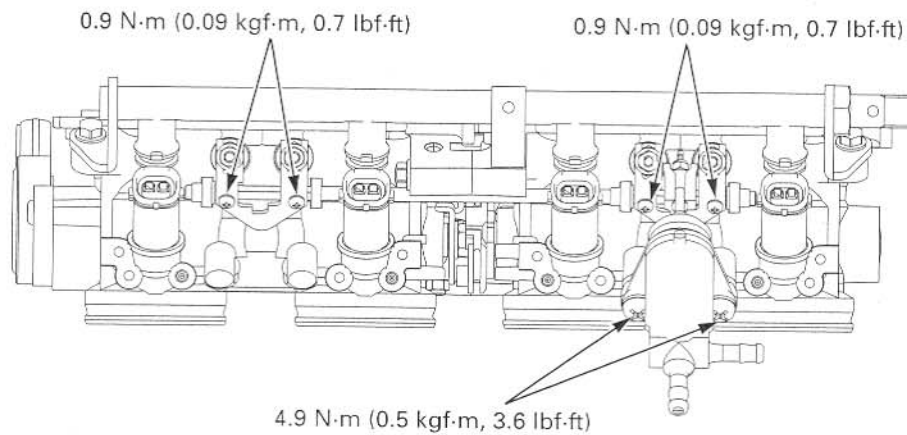

FUEL SYSTEM (Programmed Fuel Injection)

THROTTLE DRUM VIEW:

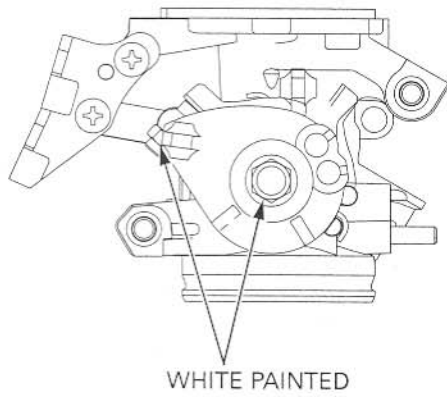

RIGHT SIDE VIEW:

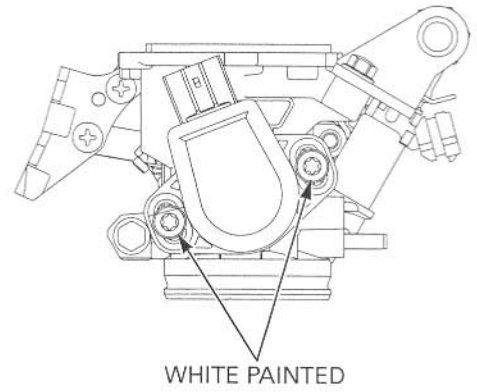

THROTTLE LINK VIEW:

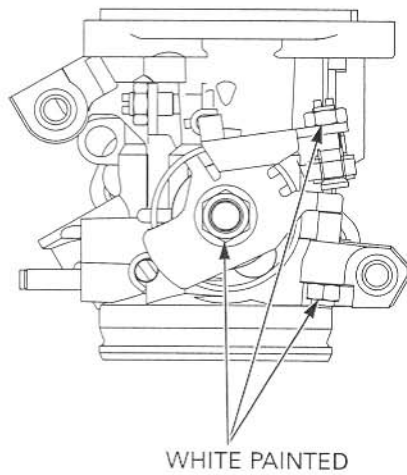

STARTER VALVE LINK VIEW:

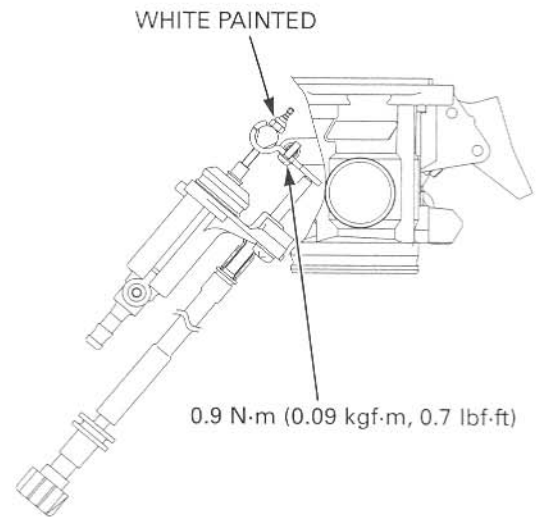

FUEL SYSTEM (Programmed Fuel Injection)

**THROTTLE BODY VACUUM HOSE
ROUTING**

Except California type:

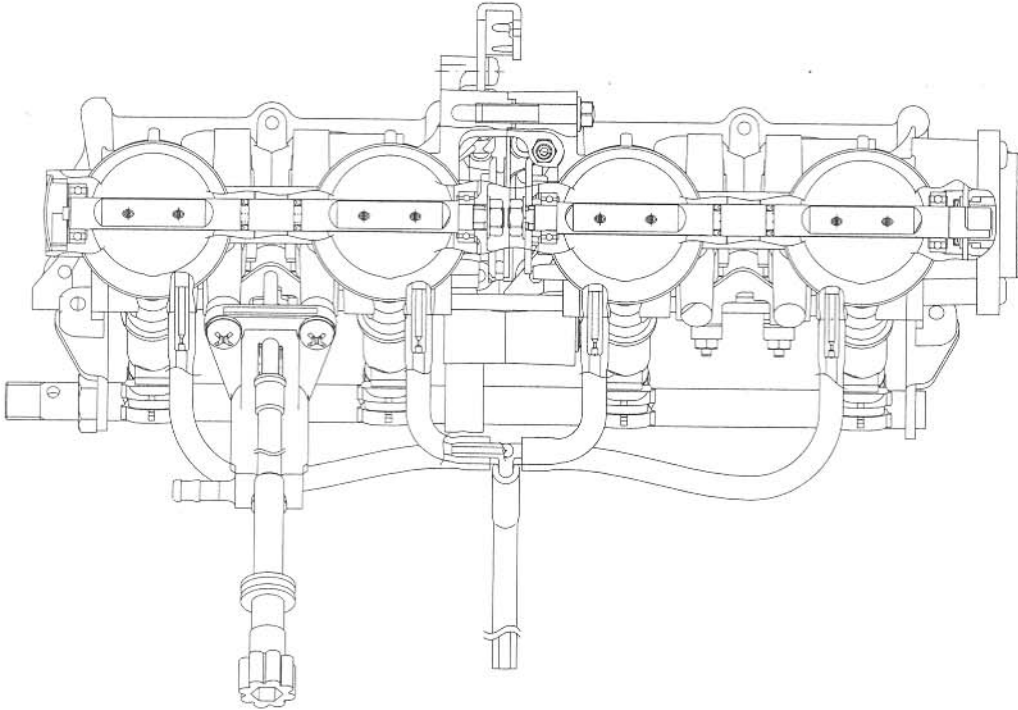

California type:

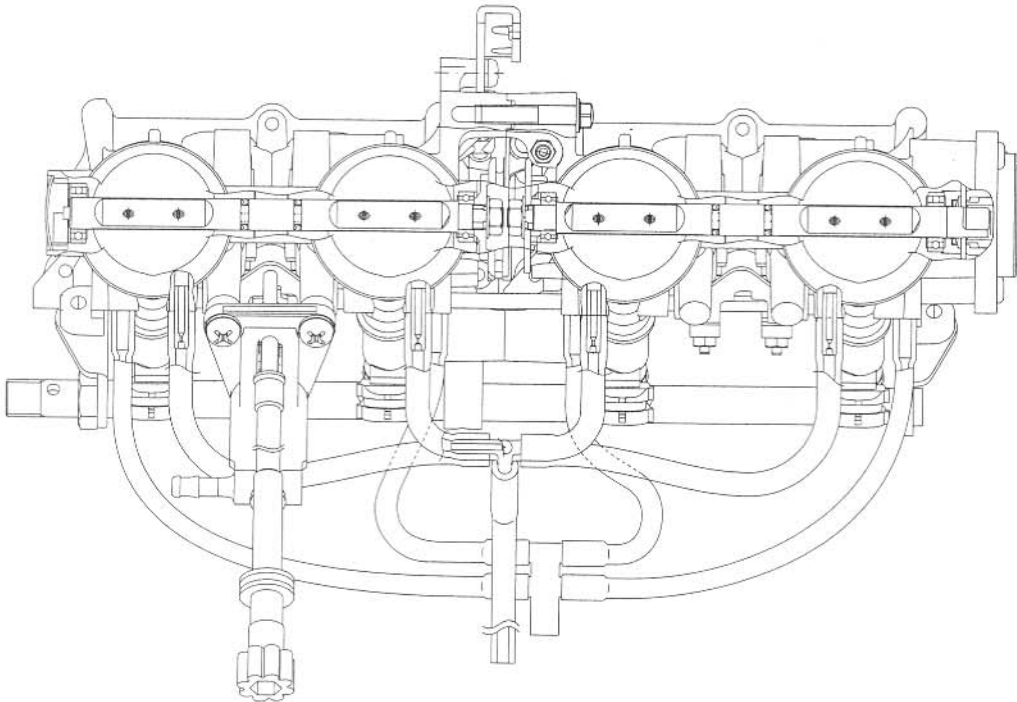

INSTALLATION

Check the insulator band angle.
Install the insulators onto the throttle body.

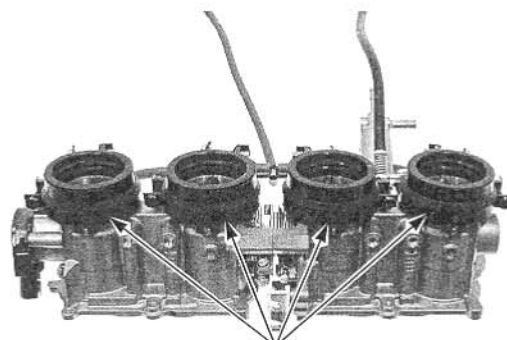

Tighten the throttle body side insulator band screw so that the insulator band distance is 12 ± 1 mm (0.5 ± 0.04 in).

Apply oil to the insulator inside surfaces for ease of throttle body installation.

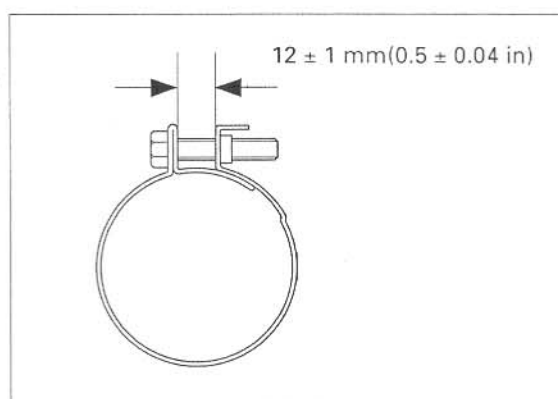

Route the throttle cables properly (page 1-22).

Connect the throttle cable ends to the throttle drum.

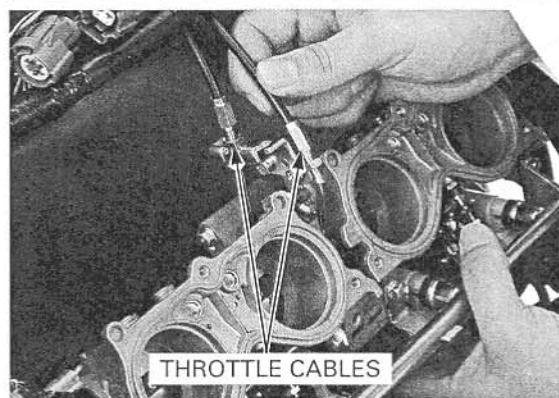

Do not hold the fuel pipe on the throttle body to install the throttle body.

Install the throttle body onto the cylinder head.

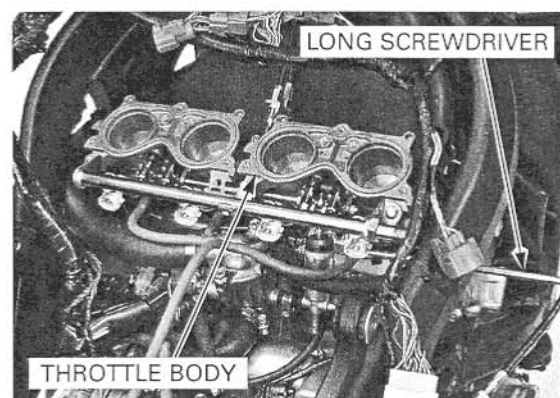

FUEL SYSTEM (Programmed Fuel Injection)

Tighten the engine side insulator band so that the insulator band distance is 10 ± 1 mm (0.4 ± 0.04 in).

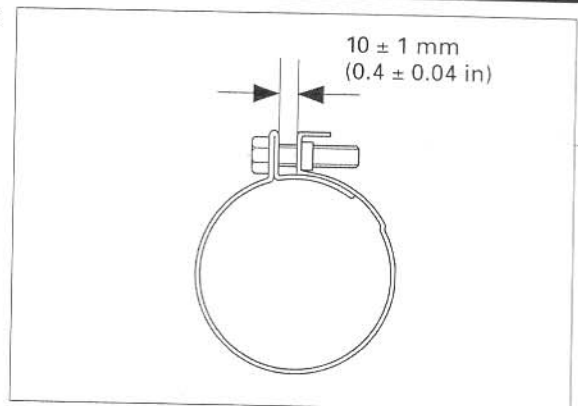

Install the tool box, stay and tighten the bolt securely.

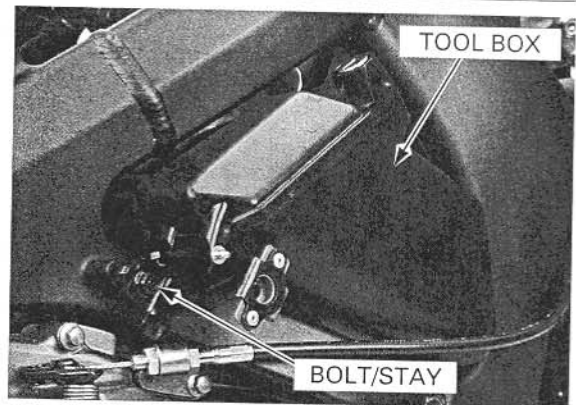

Connect the fast idle wax unit water hoses to the wax unit and tighten the hose clamp screws.

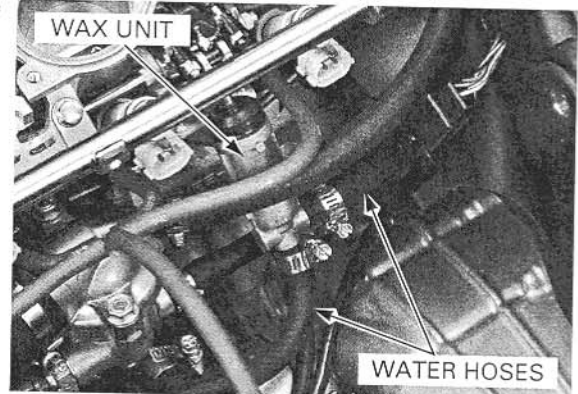

Connect the TP sensor connector and primary injector connectors.

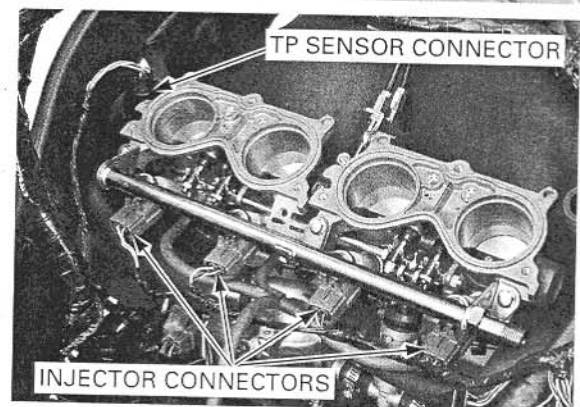

FUEL SYSTEM (Programmed Fuel Injection)

California type only: Connect the EVAP purge control solenoid valve hose from the 5-way joint.

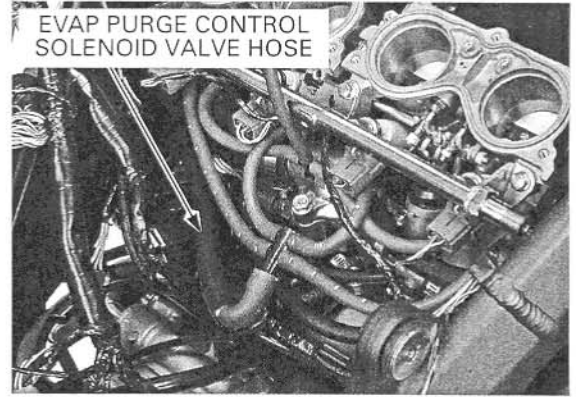

Route the throttle stop screw properly, install the throttle stop screw knob to the clamp on the bypass hose.

Install the removed parts in the reverse order of removal.

After installation, adjust the throttle grip free play (page 4-6).

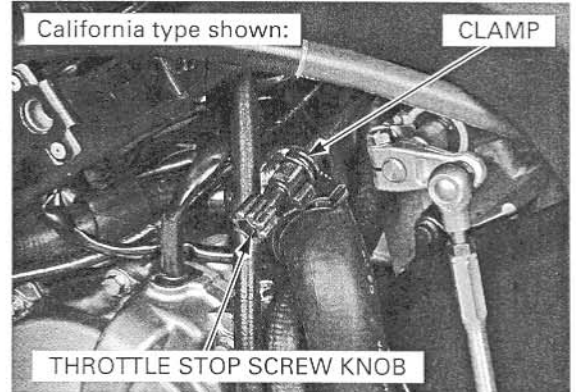

PRIMARY INJECTOR

INSPECTION

Start the engine and let it idle. Confirm the injector operating sounds with a sounding rod or stethoscope.

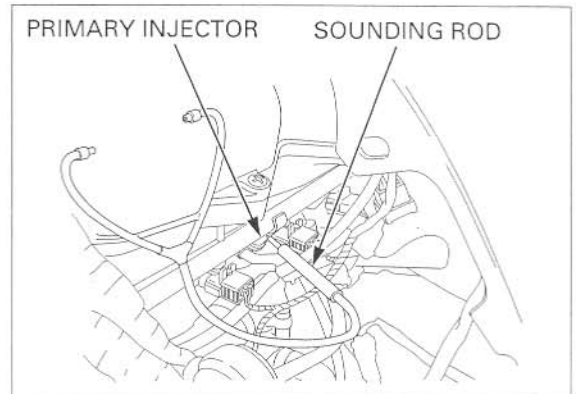

REMOVAL

Remove the throttle body (page 6-72).

Remove the bolts and fuel rail/primary injector assembly.

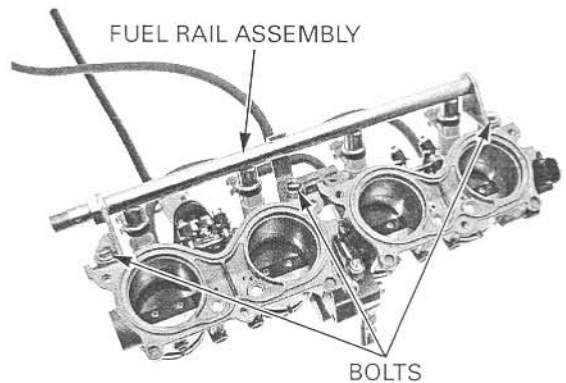

FUEL SYSTEM (Programmed Fuel Injection)

Remove the injectors from the fuel rail.



Remove the seal ring, O-ring and cushion ring.

INSTALLATION

Apply oil to the new O-ring.

Replace the seal ring, cushion ring and O-ring with new ones as a set.

Install the new seal ring, cushion ring and O-ring, being careful not to damage the O-ring.

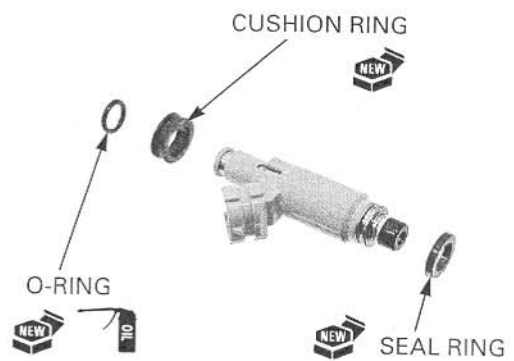

Install the fuel injectors into the fuel rail, being careful not to damage the O-ring and cushion ring.



Install the fuel rail/primary injector assembly onto the throttle body, being careful not to damage the seal rings.

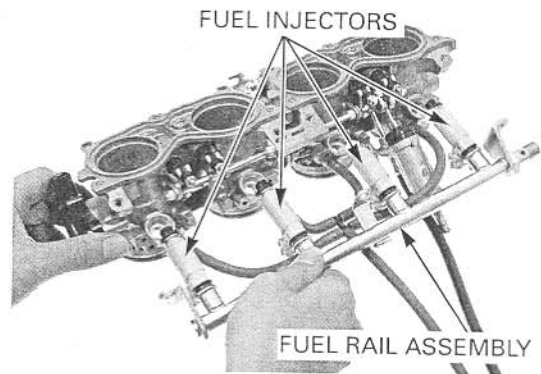

FUEL SYSTEM (Programmed Fuel Injection)

Tighten the fuel rail mounting bolts to the specified torque.

TORQUE: 9.8 N·m (1.0 kgf·m, 7 lbf·ft)

Install the throttle body (page 6-77).

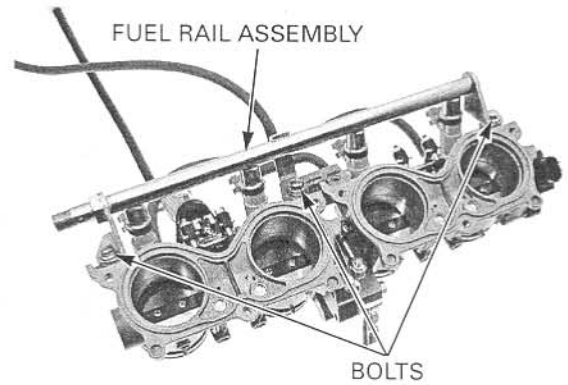

FAST IDLE WAX UNIT

REMOVAL/INSTALLATION

Do not loosen or remove the wax unit shaft lock nut and adjusting nut.

Remove the throttle body (page 6-72).

Remove the wax unit mounting screws.

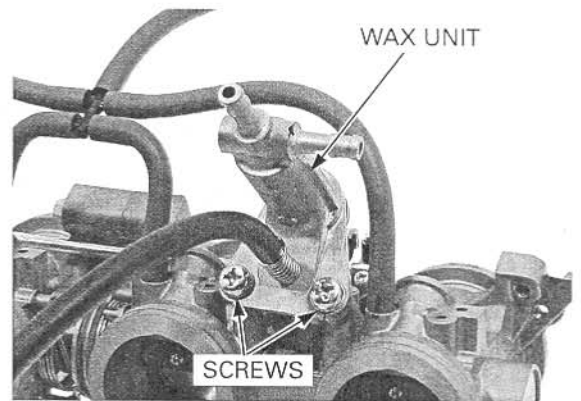

Release the wax unit shaft joint piece from the wax unit link arm, then remove the wax unit assembly.

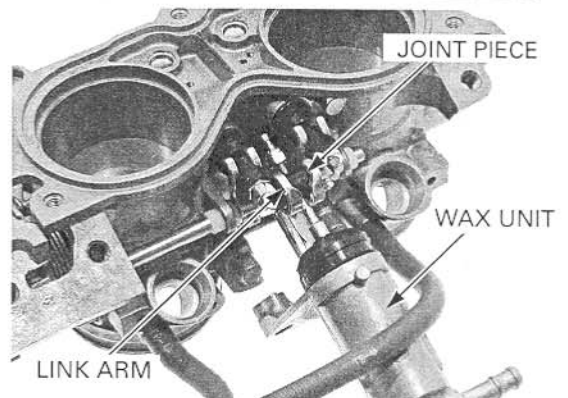

Remove the boot.

Remove the snap ring from the wax unit assembly.

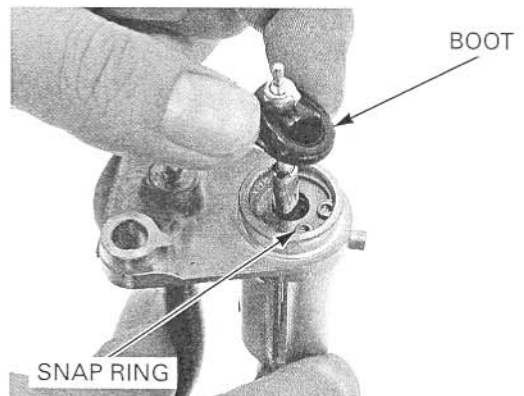

FUEL SYSTEM (Programmed Fuel Injection)

Tighten the wax unit mounting screws to the specified torque.

TORQUE: 4.9 N·m (0.5 kgf·m, 3.6 lbf·ft)

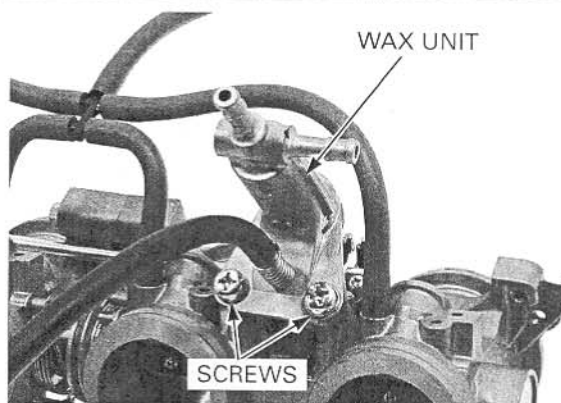

STARTER VALVE

DISASSEMBLY

Remove the throttle body (page 6-72).
Remove the fuel rail and primary injectors (page 6-79).

Turn each starter valve adjusting screw in, recording the number of turns until it seats lightly.

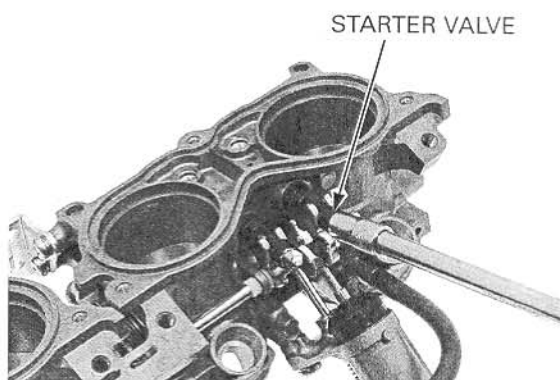

No.1/2 starter valve:

Remove the starter valve arm screws and starter valve arms.

No.3/4 starter valve:

Remove the fast idle wax unit (page 6-81).
Remove the starter valve arm screws and starter valve arm.
Remove the screw and fast idle wax unit link arm.

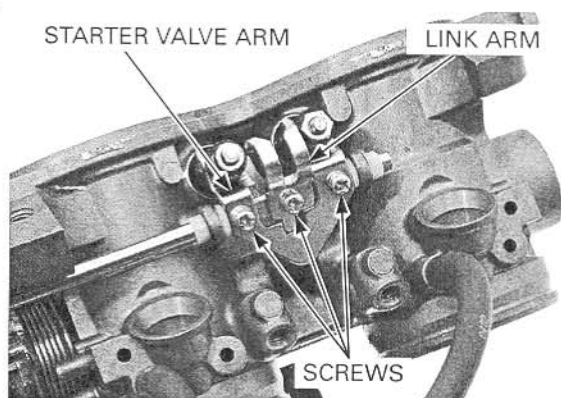

Remove the starter valve shaft and three collars.

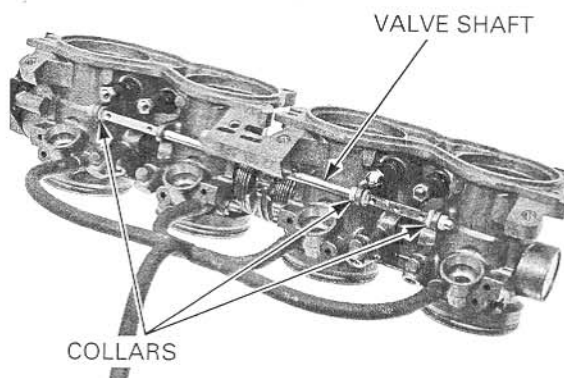

FUEL SYSTEM (Programmed Fuel Injection)

Mark the starter valves during disassembly so they can be placed back in their original locations.

Loosen the lock nut and remove the starter valves.

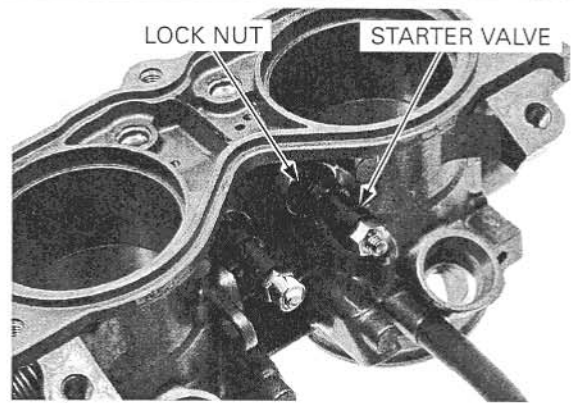

Check the starter valve for scratches, scoring or other damage, replace it if necessary.

STARTER VALVE



Do not apply commercially available carburetor cleaners to the inside of the throttle bore, which is coated with molybdenum.

Clean the starter valve bypasses using compressed air.

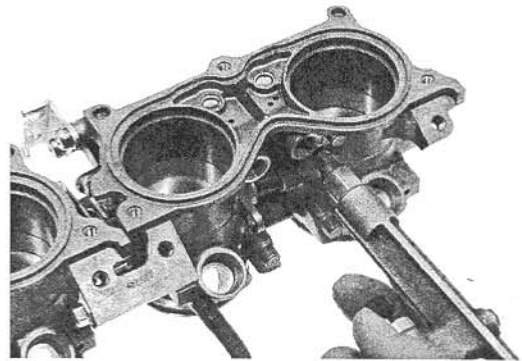

FUEL SYSTEM (Programmed Fuel Injection)

ASSEMBLY

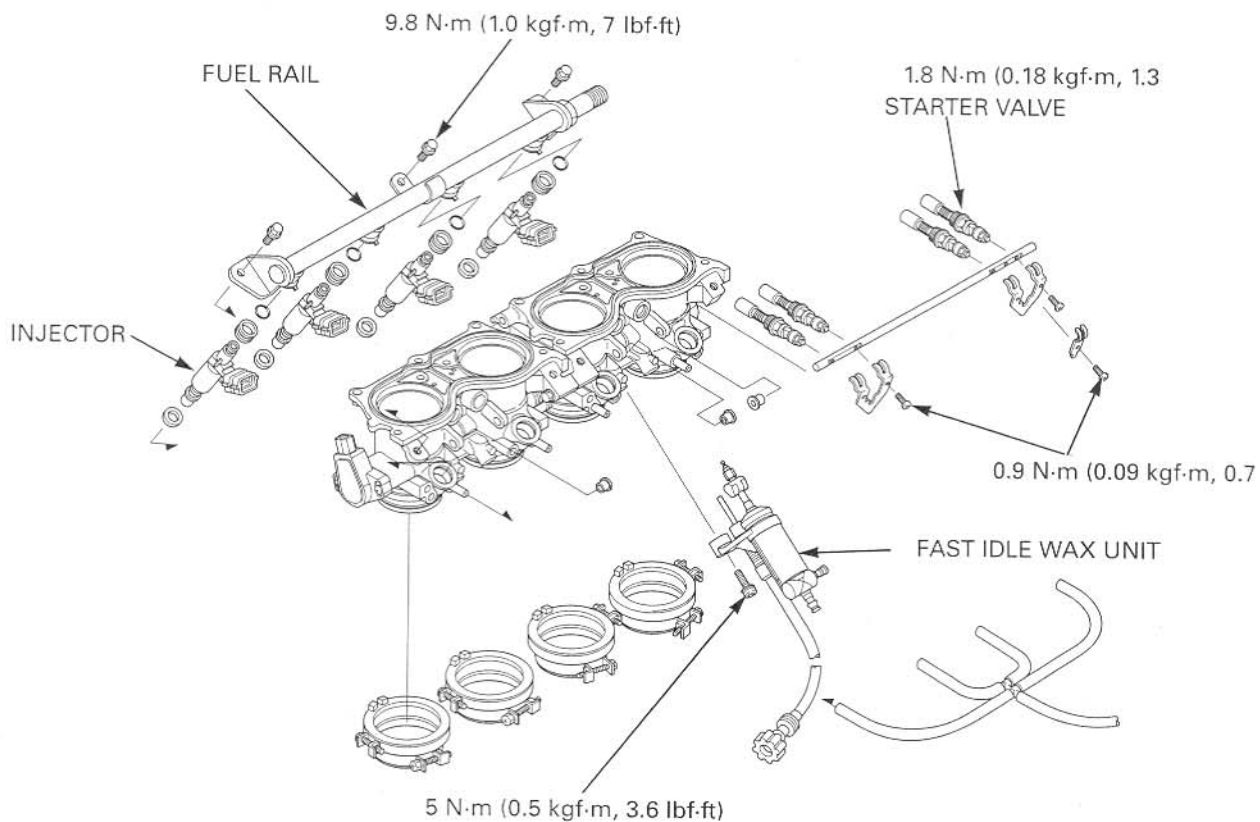

Install the starter valves into the valve holes.

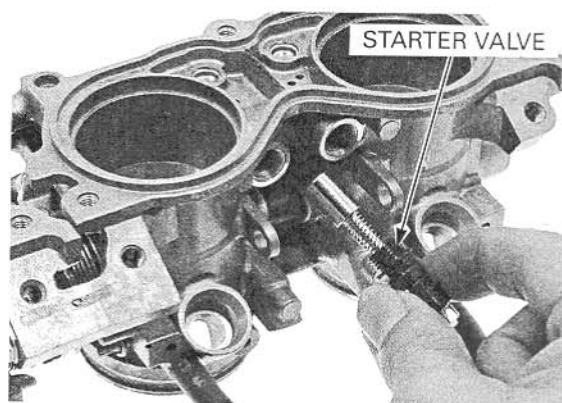

Tighten the starter valve lock nut to the specified torque.

TORQUE: 1.8 N·m (0.18 kgf·m, 1.3 lbf·ft)

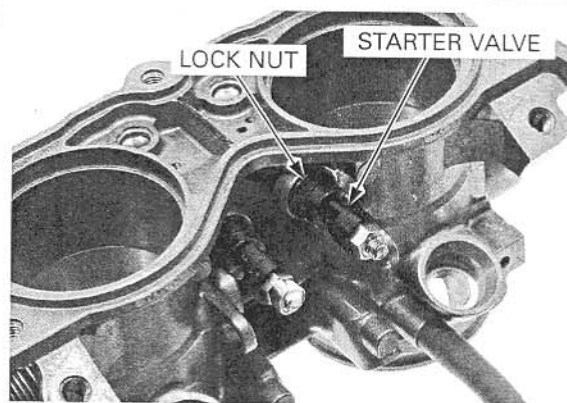

FUEL SYSTEM (Programmed Fuel Injection)

Install the three collars and starter valve shaft.

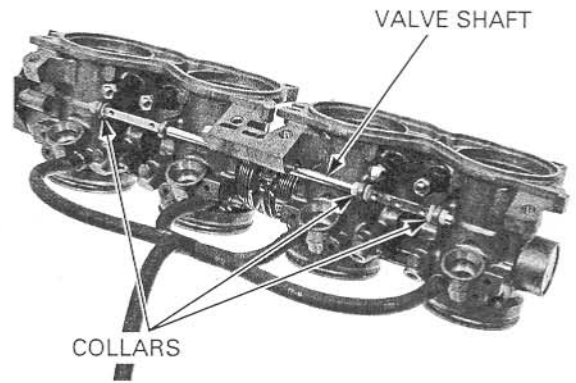

No.1/2 starter valve:

Install the No.1/2 starter valve arm to the starter valves.

Install and tighten the starter valve arm mounting screws to the specified torque.

TORQUE: 0.9 N·m (0.09 kgf·m, 0.7 lbf·ft)

No.3/4 starter valve:

Compress the thrust spring and install the No.3/4 starter valve arm onto the starter valves.

Install and tighten the starter valve arm mounting screws to the specified torque.

TORQUE: 0.9 N·m (0.09 kgf·m, 0.7 lbf·ft)

Install the fast idle wax unit link arm and tighten the screw to the specified torque.

TORQUE: 0.9 N·m (0.09 kgf·m, 0.7 lbf·ft)

Install the fast idle wax unit (page 6-81).

Turn the starter valve screw until it seats lightly, then back it out as noted during removal.

Install the throttle body (page 6-77).

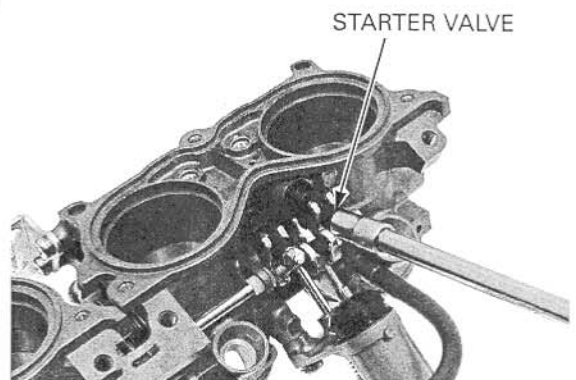
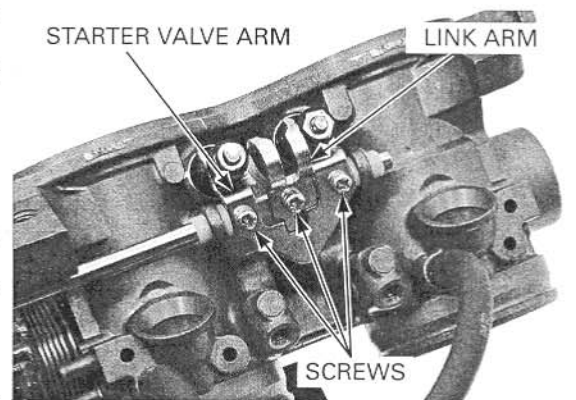

FUEL SYSTEM (Programmed Fuel Injection)

STARTER VALVE SYNCHRONIZATION

- Synchronize the starter valve with the engine at normal operating temperature and with the transmission in neutral.
- Use a tachometer with graduations of 50 rpm or smaller that will accurately indicate 50 rpm change.

Lift and support the fuel tank (page 6-61).

Disconnect the each vacuum hose from the 5-way joint.

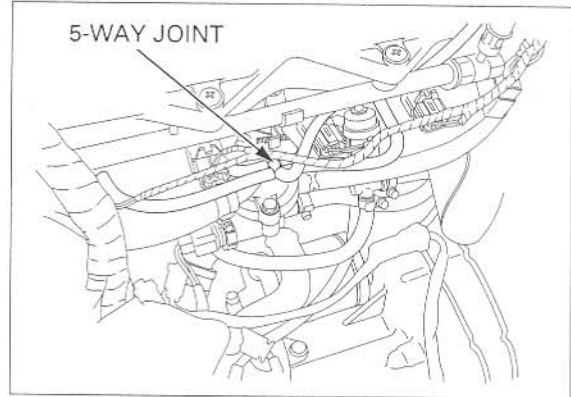

Connect the vacuum hoses to the vacuum gauge.
Connect a tachometer.

TOOL:

Vacuum gauge set

07LMJ-001000A

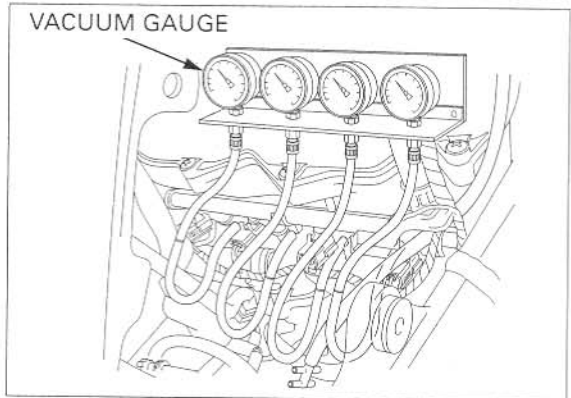

Disconnect the PAIR air suction hoses from the reed valve covers, then plug the covers.

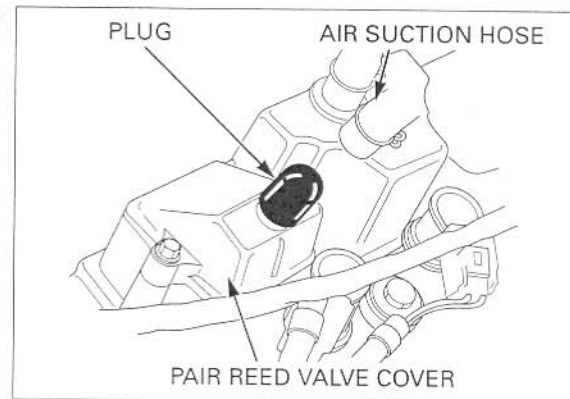

FUEL SYSTEM (Programmed Fuel Injection)

Start the engine and adjust the idle speed with the throttle stop screw.

IDLE SPEED: 1,300 ± 100 rpm

The No.3 starter valve cannot be adjusted, it is the base starter valve. Match each intake vacuum pressure with the No.3 starter valve.

STARTER VALVE VACUUM DIFFERENCE:
20 mmHg

Remove the plugs and connect the PAIR air suction hoses to the reed valve covers.

Adjust the idle speed if the idle speed differs from the specified speed.

IDLE SPEED: 1,300 ± 100 rpm

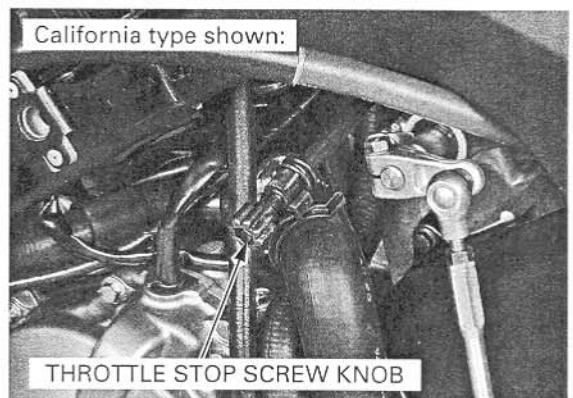
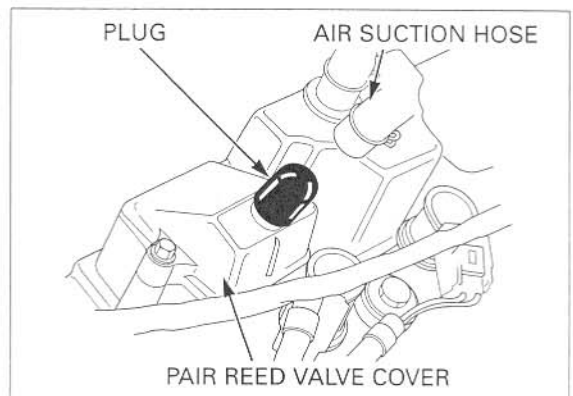
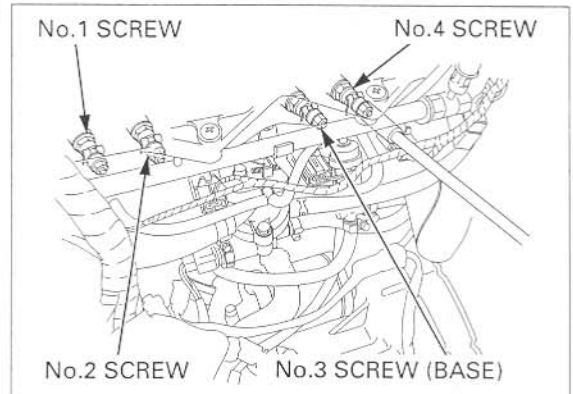
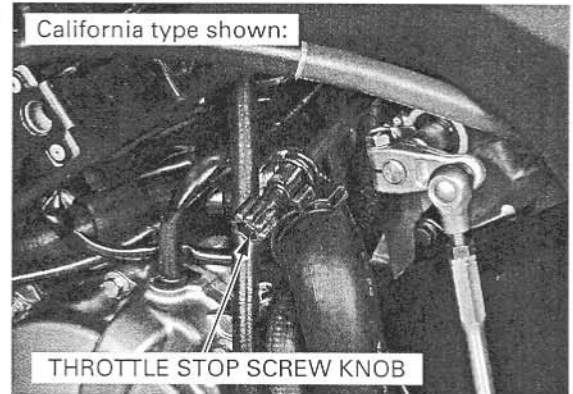

FUEL SYSTEM (Programmed Fuel Injection)

Remove the vacuum gauge from the vacuum hoses.
Connect the each vacuum hoses to the 5-way joint.
Reset the ECM failure code (page 6-9).

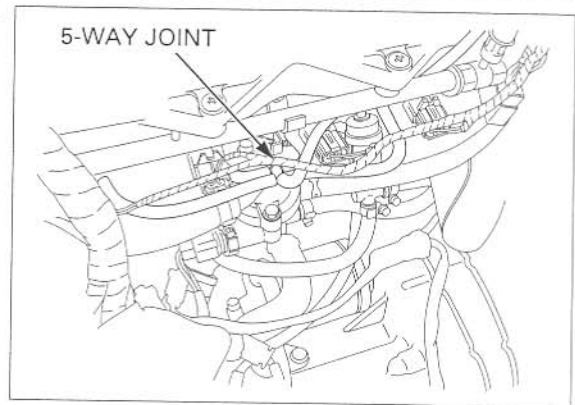

MAP SENSOR

OUTPUT VOLTAGE INSPECTION

Connect the test harness to the ECM (page 6-10).

Measure the voltage at the test harness terminals (page 6-11).

Connection: B15 (+) – B17 (–)

STANDARD: 2.7 – 3.1 V

The MAP sensor output voltage (above) is measured under the standard atmosphere (1 atm = 1,013 hPa).

The MAP sensor output voltage is affected by the distance above sea level, because the output voltage is changed by atmosphere.

Check the sea level measurement and be sure that the measured voltage falls within the specified value.

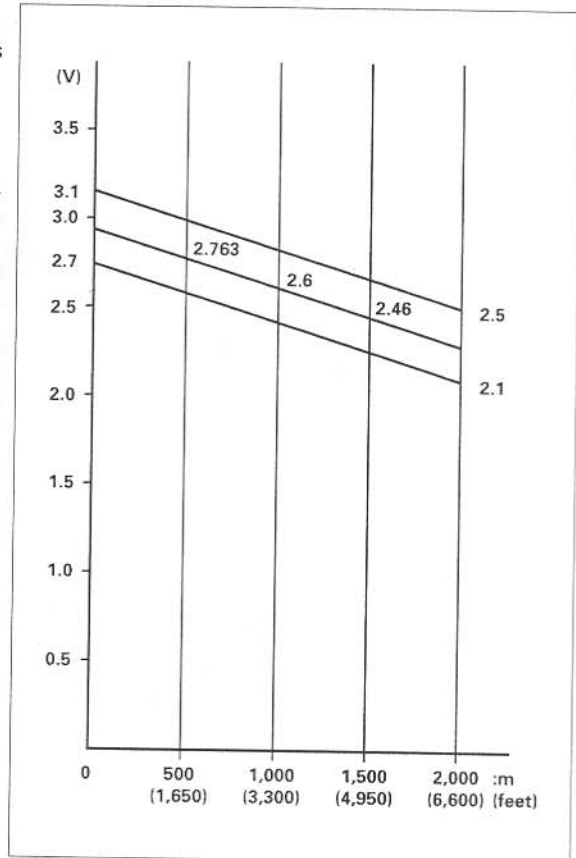

REMOVAL/INSTALLATION

Lift and support the fuel tank (page 6-61).

Disconnect the MAP sensor connector.
Disconnect the vacuum hose from the MAP sensor.

Remove the screw and MAP sensor from the air cleaner housing.

Installation is in the reverse order of removal.

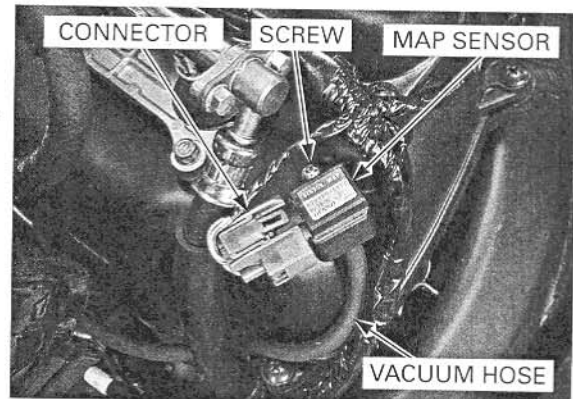

IAT SENSOR

REMOVAL/INSTALLATION

Remove the air cleaner housing cover (page 4-6).

Remove the screws and IAT sensor from the air cleaner housing cover.

Installation is in the reverse order of removal.

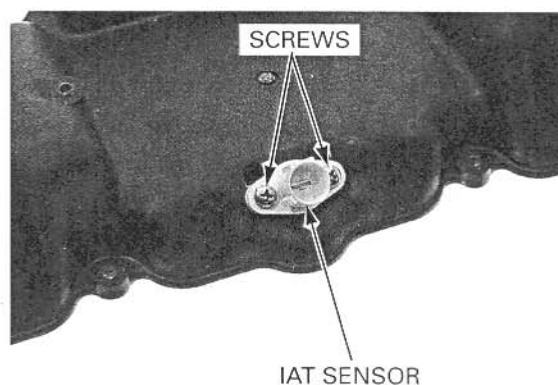

ECT SENSOR

Replace the ECT sensor while the engine is cold.

REMOVAL/INSTALLATION

Drain the coolant from the system (page 7-6).

Disconnect the ECT sensor connector from the sensor.

Remove the ECT sensor and sealing washer.

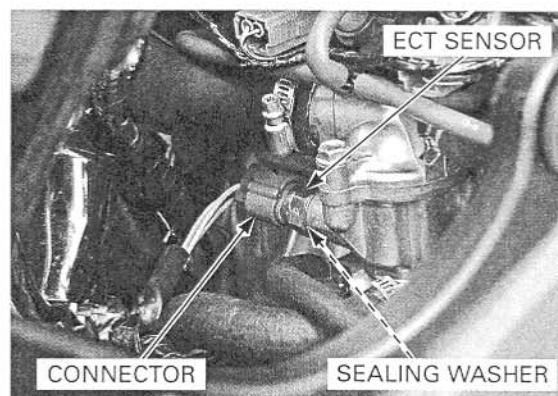

Always replace a sealing washer with a new one.

Install a new sealing washer and ECT sensor.

Tighten the ECT sensor to the specified torque.

TORQUE: 23 N·m (2.3 kgf·m, 17 lbf·ft)

Connect the ECT sensor connector.

Fill the cooling system with recommended coolant (page 7-6).

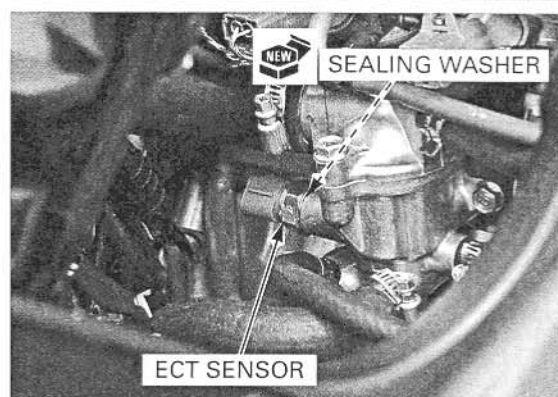

FUEL SYSTEM (Programmed Fuel Injection)

CAM PULSE GENERATOR

REMOVAL/INSTALLATION

Remove the following:

- Lower cowls (page 3-6)
- Middle cowls (page 3-7)

Lift and support the fuel tank (page 6-61).

Disconnect the cam pulse generator 2P (Natural) connector.

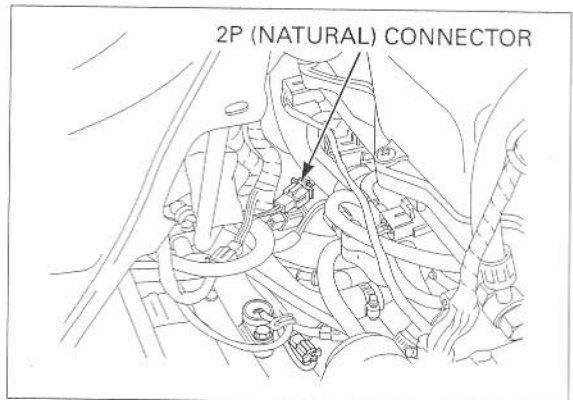

Remove the bolt, clamp and cam pulse generator from the cylinder head.

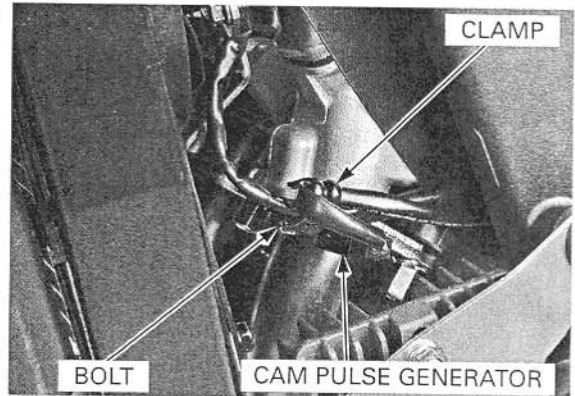

Apply oil to a new O-ring and install it onto the cam pulse generator.
Install the cam pulse generator into the cylinder head.

Tighten the mounting bolt securely.

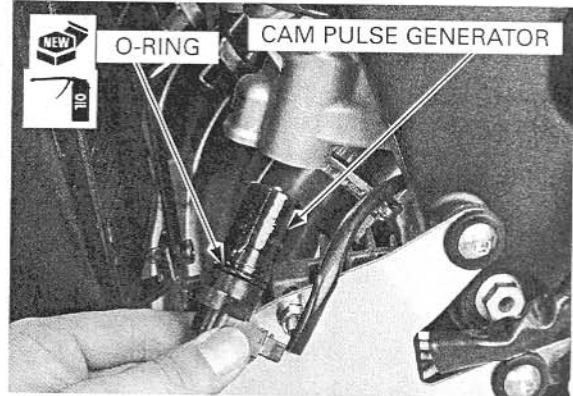

Route the cam pulse generator wire properly, connect the 2P (Natural) connector.

Install the removed parts in the reverse order of removal.

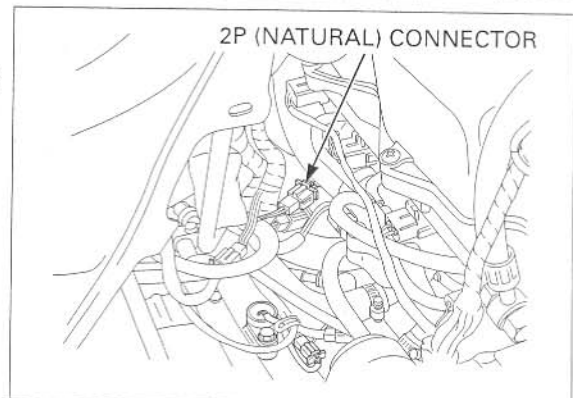

TP SENSOR

INSPECTION

Remove the fuel tank cover (page 3-15).
 Disconnect the ECM 32P (Black) and 32P (Light gray) connectors.
 Check the connector for loose or corroded terminals.
 Connect the ECM test harness between the ECM and main wire harness.

TOOL:
 ECM test harness **070MZ-0010200**
 (two required)

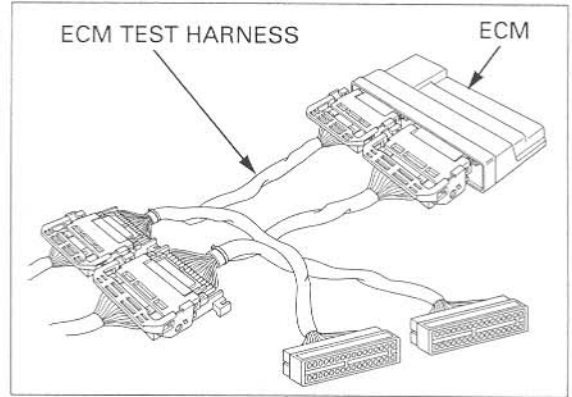

INPUT VOLTAGE INSPECTION

Turn the ignition switch ON and measure and record the input voltage at the test harness terminals using a digital multimeter.

Connection: B18 (+) – B17 (-)

Standard: 4.2 – 4.8 V

If the measurement is out of specification, check the following:

- Loose connection of the ECM multi-connector
- Open circuit in wire harness

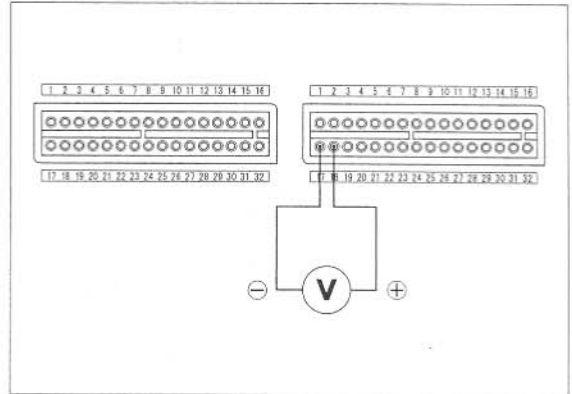

OUTPUT VOLTAGE INSPECTION WITH THE THROTTLE FULLY OPENED

Turn the ignition switch ON and measure and record the output voltage at the test harness terminals.

Connection: B14 (+) – B17 (-)

Measuring condition:
 At throttle fully opened

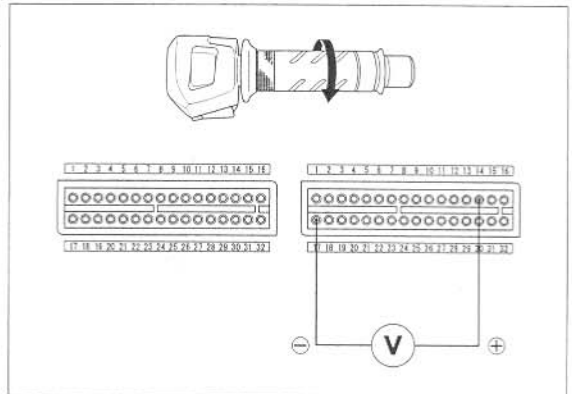

FUEL SYSTEM (Programmed Fuel Injection)

OUTPUT VOLTAGE INSPECTION WITH THE THROTTLE FULLY CLOSED

Turn the ignition switch ON and measure and record the output voltage with the throttle fully closed.

Connection: B14 (+) – B17 (-)

Measuring condition:

At throttle fully closed

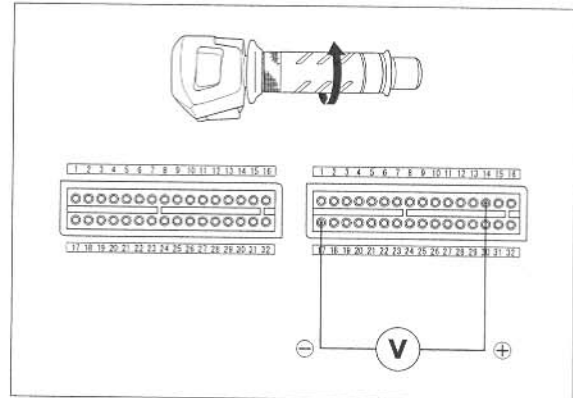

CALCULATE RESULT COMPARISON

Compare the measurement to the result of the following calculation.

With the throttle fully opened:

Measured input voltage X 0.824 = V_o

The sensor is normal if the measurement output voltage is within 10% of V_o .

With the throttle fully closed:

Measured input voltage X 0.1 = V_c

The sensor is normal if the throttle closed output voltage is within 10% of V_c .

Using an analog meter, check that the needle of the voltmeter swings slowly when the throttle is opened gradually.

CONTINUITY INSPECTION

Lift and support the fuel tank (page 6-61).

Disconnect the ECM 32P connectors and the TP sensor 3P connector.

Check for continuity between the ECM 32P (Light gray) connector and TP sensor 3P connector terminal of the wire harness.

Connection: Yellow/red – B14

If there is no continuity, check the open or short circuit in wire harness.

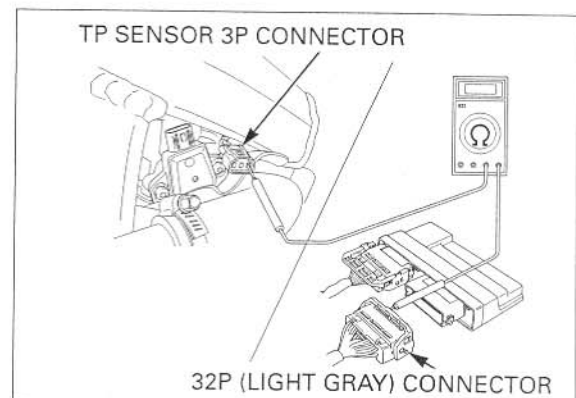

BANK ANGLE SENSOR

INSPECTION

Remove the upper cowl (page 3-9) with the connectors connected.

Turn the ignition switch ON and engine stop switch "O".

Measure the voltage between the following terminals of the bank angle sensor connector with the connector connected.

TERMINAL	STANDARD
White/black (+) - Green (-)	Battery voltage
Red/white (+) - Green (-)	0 - 1 V

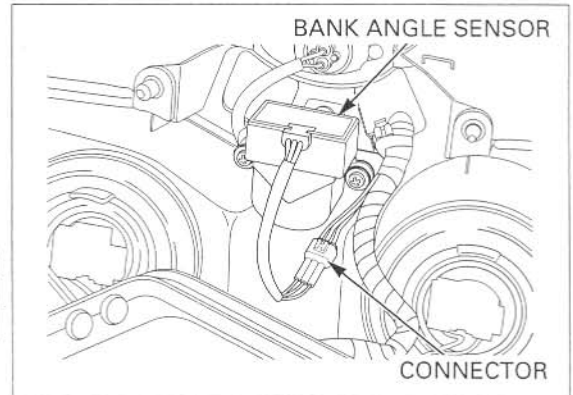

Do not disconnect the bank angle sensor connector during inspection.

Turn the ignition switch OFF.

Remove the screws, washer and bank angle sensor.

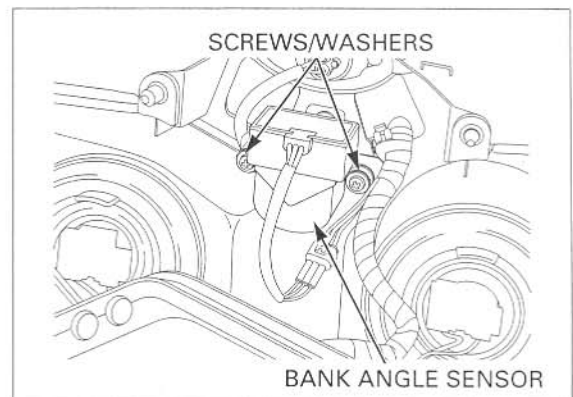

Place the bank angle sensor horizontal as shown, and turn the ignition switch ON.

The bank angle sensor is normal if the engine stop relay clicks and power supply is closed.

Incline the bank angle sensor approximately 60 degrees to the left or right with the ignition switch ON.

The bank angle sensor is normal if the engine stop relay clicks and power supply is open.

If you repeat this test, first turn the ignition switch OFF, then turn the ignition switch ON.

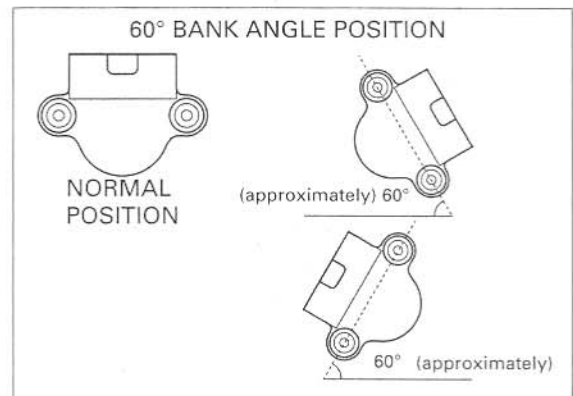

REMOVAL/INSTALLATION

Disconnect the bank angle sensor 3P (Black) connector.

Remove the two screws, washers and bank angle sensor.

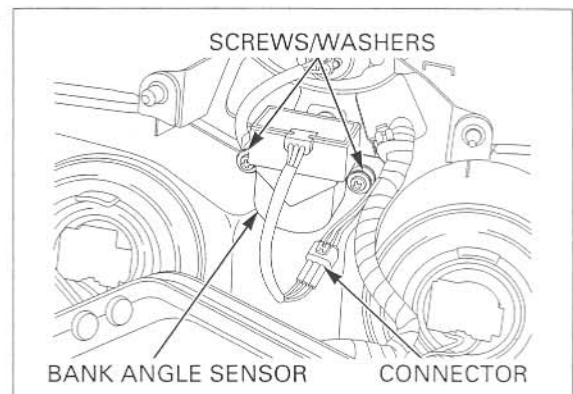

FUEL SYSTEM (Programmed Fuel Injection)

Install the bank angle sensor with its "UP" mark facing up.

Installation is in the reverse order of removal.
Tighten the mounting screws securely.

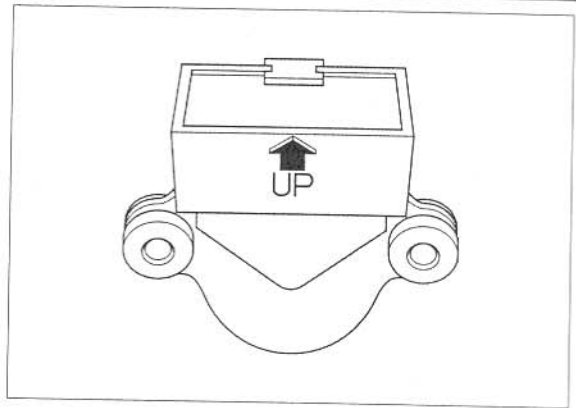

ENGINE STOP RELAY

INSPECTION

Remove the following:

- Lower cowls (page 3-6)
- Middle cowls (page 3-7)

Disconnect the engine stop relay 4P connector, remove the engine stop relay.

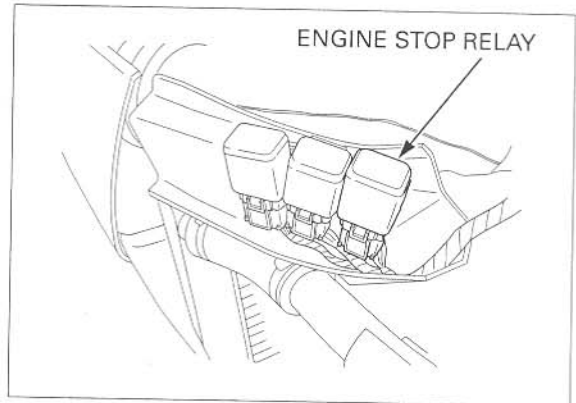

Connect the ohmmeter to the engine stop relay connector terminals.

Connection: A - B

Connect a 12 V battery to the following engine stop relay connector terminals.

Connection: C (+) - D (-)

There should be continuity only when the 12 V battery is connected.

If there is no continuity when the 12 V battery is connected, replace the engine stop relay.

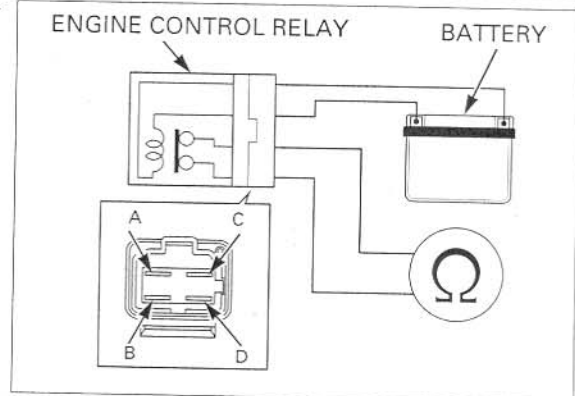

ENGINE CONTROL MODULE (ECM)

REMOVAL/INSTALLATION

Remove the fuel tank cover (page 3-15).

Remove the two screws and ECM cover.

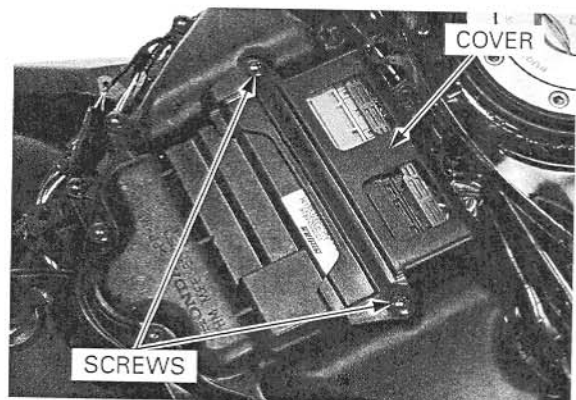

FUEL SYSTEM (Programmed Fuel Injection)

Disconnect the ECM 32P (Black) and 32P (Light gray) connectors.

Remove the ECM.

Installation is in the reverse order of removal.

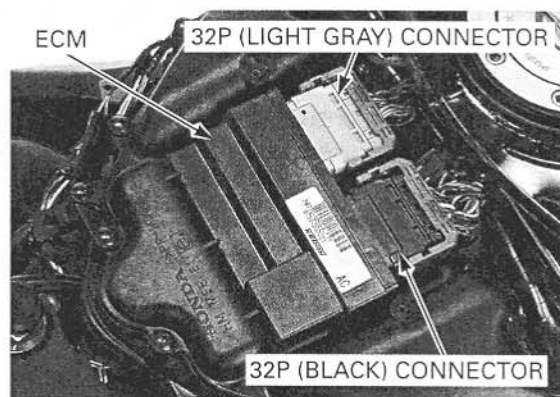

ECM POWER/GROUND LINE INSPECTION

ENGINE DOES NOT START (MIL DOES NOT BLINK)

1. ECM Power Input Voltage Inspection

Disconnect the ECM 32P (Black) and 32P (Light gray) connectors.

Turn the ignition switch ON and engine stop switch "Q".

Measure the voltage at the ECM 32P (Light gray) connector terminal and ground.

Connection: B16 (+) – Ground (-)

Is there battery voltage?

YES – GO TO STEP 2.

NO – GO TO STEP 3.

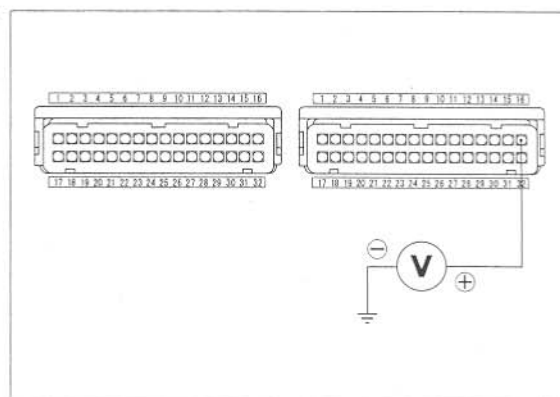

2. ECM Ground Line Inspection

Turn the ignition switch OFF.

Check for continuity between the ECM 32P (Black) connector terminals and ground.

Connection: A4 (+) – Ground (-)

A18 (+) – Ground (-)

Are there continuities?

YES – Replace the ECM with a know good one, and recheck.

NO –

- Open circuit in the Green/Pink (A18) wire
- Open circuit in the Green /Pink (A4) wire

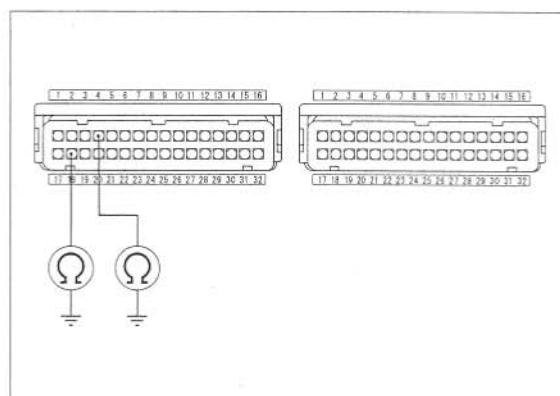

FUEL SYSTEM (Programmed Fuel Injection)

3. Engine Stop Relay Inspection 1

Turn the ignition switch OFF.
Disconnect the engine stop relay connector.

Turn the ignition switch ON and engine stop switch " \odot ".
Measure the voltage at the engine stop relay connector terminals.

Connection: Black (+) – Red/white (-)

Is there battery voltage?

YES – GO TO STEP 4.

NO – Inspect the bank angle sensor (page 6-93)

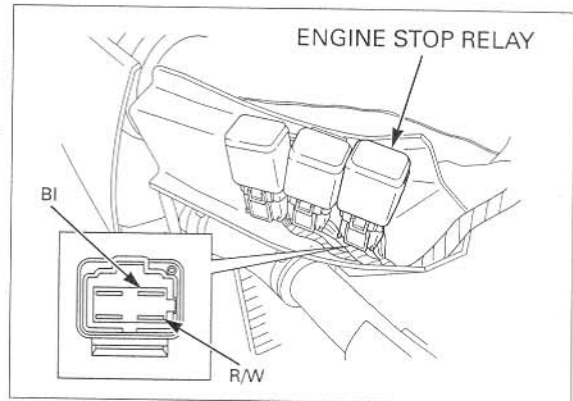

4. Engine Stop Relay Inspection 2

Turn the ignition switch OFF.
Jump the engine stop relay connector terminals.

Connection: Red/white – Black/white

Turn the ignition switch ON.
Measure the voltage at the ECM connector terminal and ground.

Connection: B16 (+) – Ground (-)

Is there battery voltage?

YES – Inspect the engine stop relay (page 6-94)

NO – Open circuit in power input line (Black/white or Red/white) between the battery and the ECM

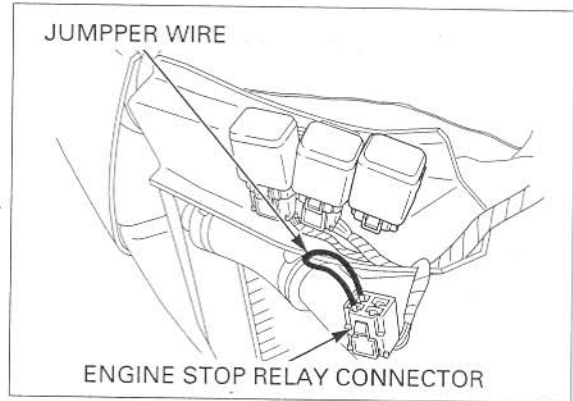

PAIR CONTROL SOLENOID VALVE

REMOVAL/INSTALLATION

Remove the air cleaner housing (page 6-64).

Disconnect the PAIR control solenoid valve 2P (Black) connector.

Disconnect the PAIR air suction hoses.

Installation is in the reverse order of removal.

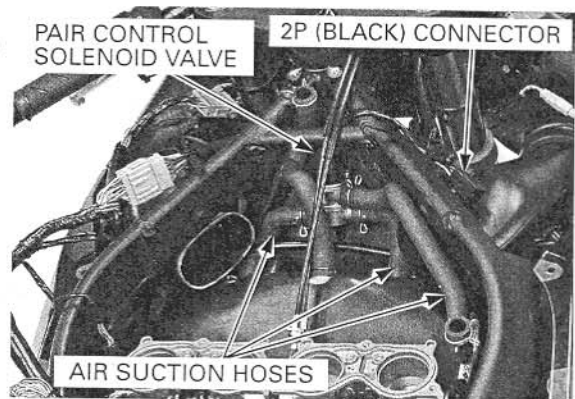

FUEL SYSTEM (Programmed Fuel Injection)

INSPECTION

Remove the PAIR control solenoid valve.

Check that air flows (A) to (B) when the 12 V battery is connected to the PAIR control solenoid valve terminals. Air should not flow (A) to (B) when there is no voltage applied to the PAIR valve terminals.

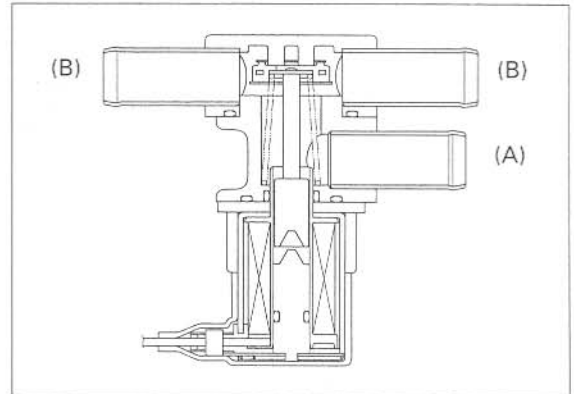

Check the resistance between the terminals of the PAIR control solenoid valve.

STANDARD: 20 – 24 Ω (20 °C/68 °F)

If the resistance is out of specification, replace the PAIR control solenoid valve.

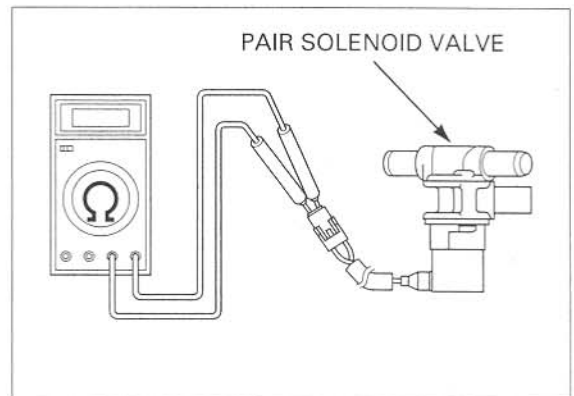

EVAP PURGE CONTROL SOLENOID VALVE (California type only)

REMOVAL/INSTALLATION

Remove the following:

- Lower cowls (page 3-6)
- Middle cowls (page 3-7)

Remove the mounting bolts, fuse box stay and EVAP purge control solenoid valve stay.

Disconnect the hoses and 2P connector from the EVAP purge control solenoid valve.

Remove the bolts/nuts and EVAP purge control solenoid valve from the stay.

Installation in the reverse order of removal.

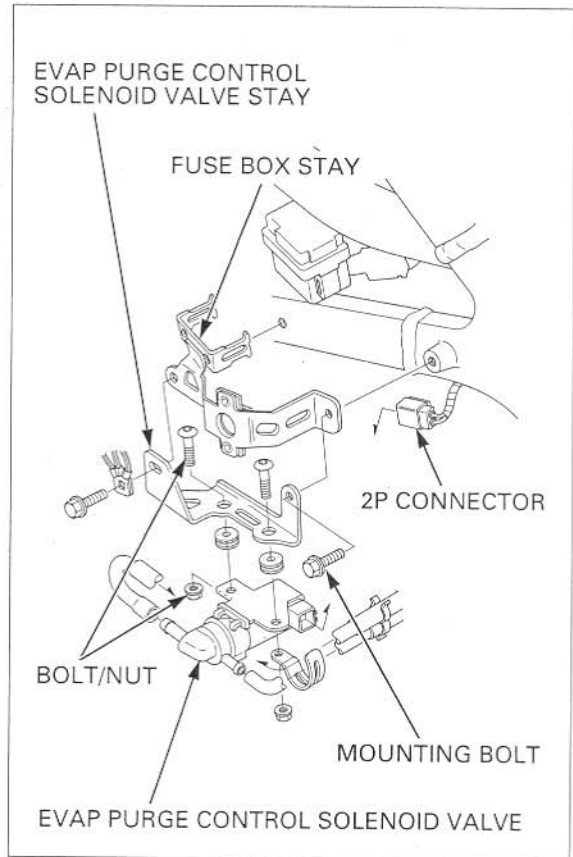

INSPECTION

Remove the EVAP purge control solenoid valve.

Check that air should not flow (A) to (B), only when the 12V battery is connected to the EVAP purge control valve terminals.

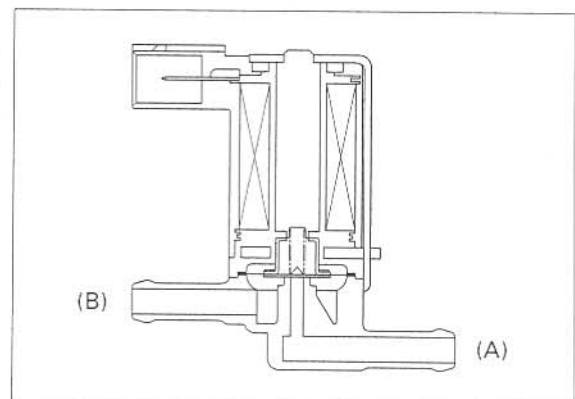

FUEL SYSTEM (Programmed Fuel Injection)

Check the resistance between the terminals of the EVAP purge control solenoid valve.

STANDARD: 30 – 34 Ω (20 °C/68 °F)

If the resistance is out of specification, replace the EVAP purge control solenoid valve.

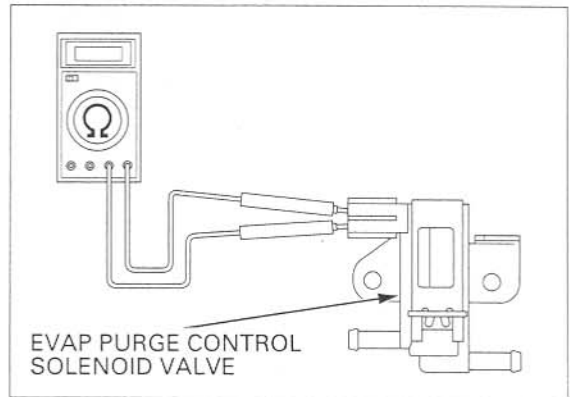

O₂ SENSOR (California type only)

REMOVAL

- Handle the O₂ sensor with care.
- Do not get grease, oil or other materials in the O₂ sensor air hole, or it may be damaged.
- Do not service the O₂ sensor while it is hot.

Remove the lower cowls (page 3-6).

Disconnect the O₂ sensor 4P (Natural) connector.

Remove the O₂ sensor wire from the frame.

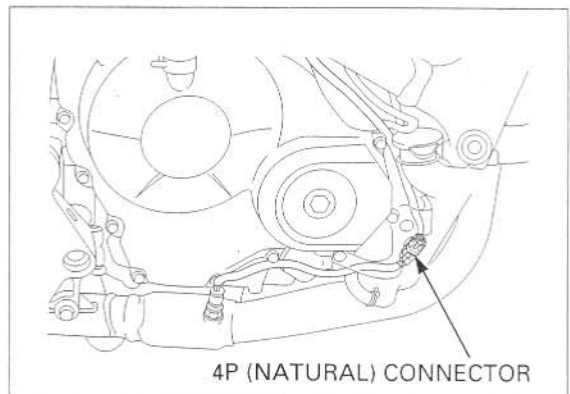
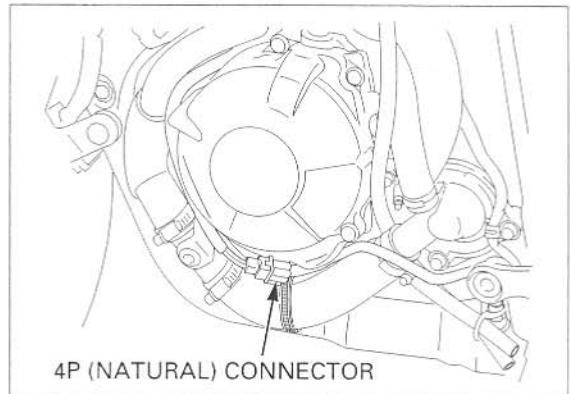

FUEL SYSTEM (Programmed Fuel Injection)

Remove the O₂ sensor unit.

- Be careful not to damage the sensor wire.
- Do not use an impact wrench while removing or installing the O₂ sensor, or it may be damaged.

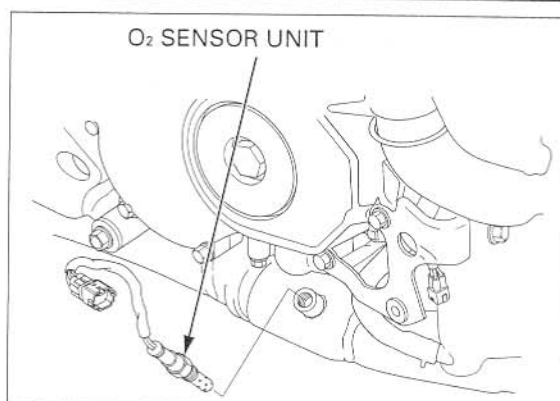

Install the O₂ sensor unit.
Tighten the unit to the specified torque.

TORQUE: 25 N·m (2.6 kgf·m, 19 lbf·ft)

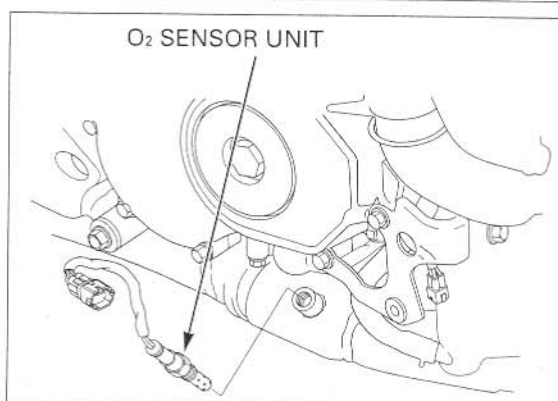

Route the O₂ sensor wire into the frame.
Connect the O₂ sensor 4P (Natural) connector.

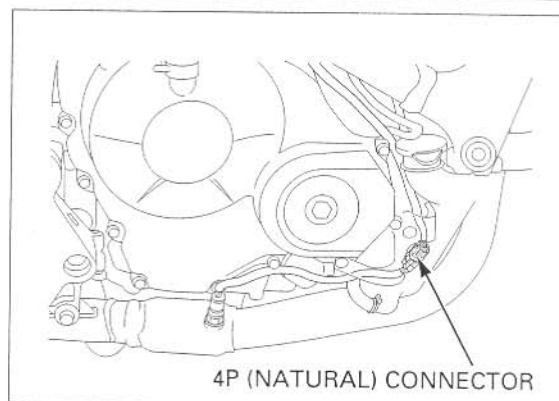
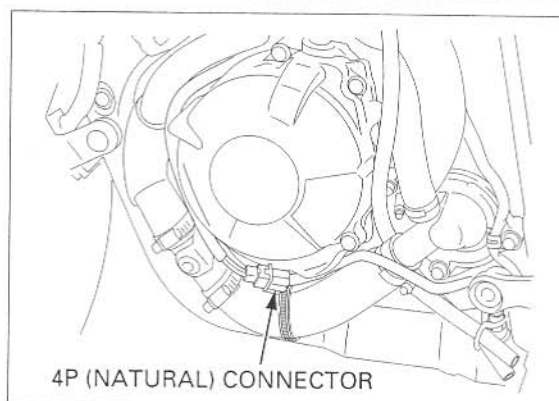

7. COOLING SYSTEM

SYSTEM FLOW PATTERN	7-2	THERMOSTAT	7-8
SERVICE INFORMATION	7-3	RADIATOR	7-10
TROUBLESHOOTING	7-4	WATER PUMP	7-15
SYSTEM TESTING.....	7-5	RADIATOR RESERVE TANK.....	7-17
COOLANT REPLACEMENT	7-6	FAN CONTROL RELAY.....	7-18

COOLING SYSTEM

SYSTEM FLOW PATTERN

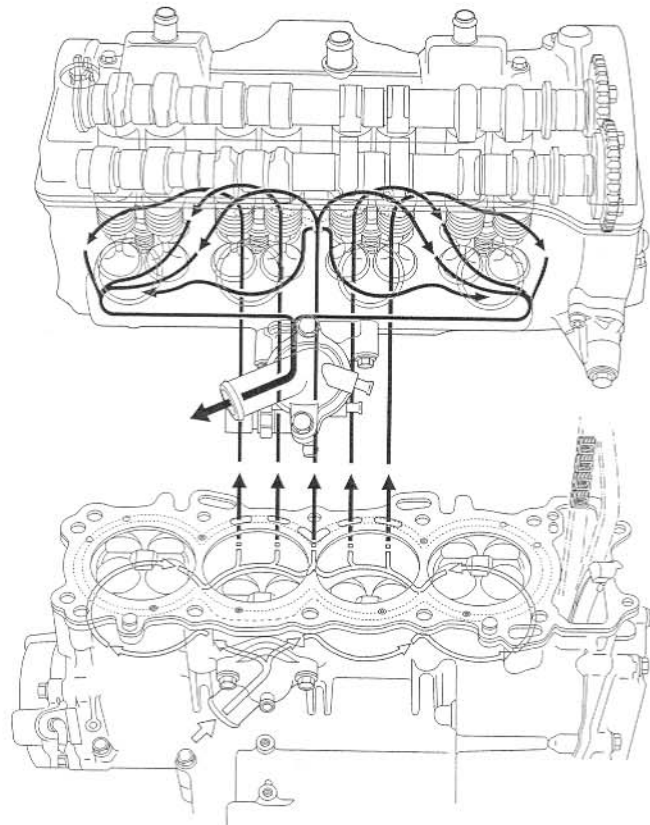
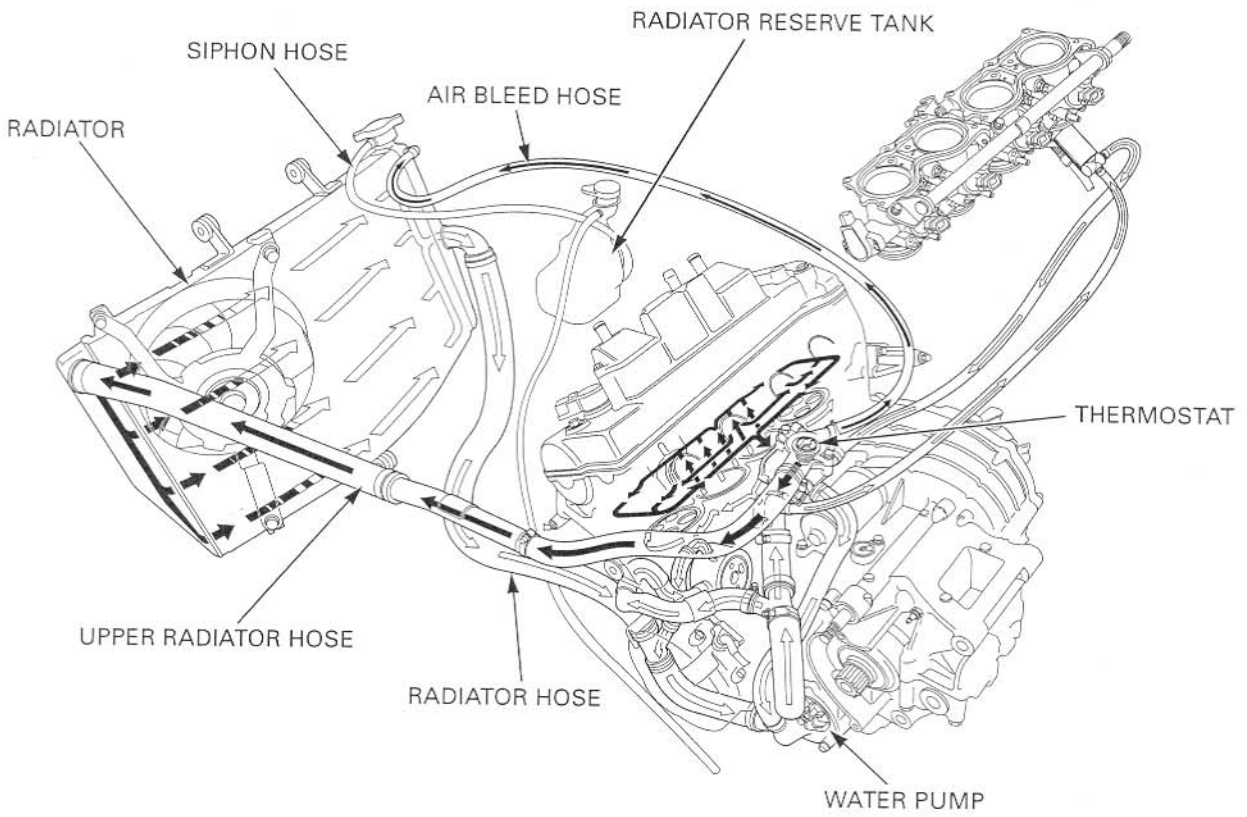

SERVICE INFORMATION

GENERAL

⚠ WARNING

Removing the radiator cap while the engine is hot can allow the coolant to spray out, seriously scalding you. Always let the engine and radiator cool down before removing the radiator cap.

NOTICE

Using coolant with silicate inhibitors may cause premature wear of water pump seals or blockage of radiator passages. Using tap water may cause engine damage.

- Add cooling system at the reserve tank. Do not remove the radiator cap except to refill or drain the system.
- All cooling system services can be done with the engine installed in the frame.
- Avoid spilling coolant on painted surfaces.
- After servicing the system, check for leaks with a cooling system tester.
- Refer to the fan control relay inspection (page 7-18) and ECT sensor inspection (page 20-16).

SPECIFICATIONS

ITEM		SPECIFICATIONS
Coolant capacity	Radiator and engine	3.2 liter (3.4 US qt, 2.8 Imp qt)
	Reserve tank	0.30 liter(0.32 US qt, 0.26 Imp qt)
Radiator cap relief pressure		108 – 137 kPa (1.1 – 1.4 kgf/cm ² , 16 – 20 psi)
Thermostat	Begin to open	80 – 84 °C (176 – 183 °F)
	Valve lift	8 mm (0.3 in) minimum at 90 °C (194 °F)
Recommended antifreeze		Pro Honda HP Coolant or an equivalent high quality ethylene glycol antifreeze containing corrosion protection inhibitors
Standard coolant concentration		1:1 mixture of antifreeze and soft water

TORQUE VALUES

Water pump assembly flange bolt	12 N·m (1.2 kgf·m, 9 lbf·ft)	CT bolt
Thermostat housing cover flange bolt	13 N·m (1.3 kgf·m, 10 lbf·ft)	CT bolt
ECT (Engine Coolant Temperature) sensor	23 N·m (2.3 kgf·m, 17 lbf·ft)	
Cooling fan nut	2.9 N·m (0.3 kgf·m, 2.2 lbf·ft)	Apply a locking agent to the threads
Fan motor nut	4.9 N·m (0.5 kgf·m, 3.6 lbf·ft)	
Fan motor shroud mounting bolt	7.8 N·m (0.8 kgf·m, 5.8 lbf·ft)	

COOLING SYSTEM

TROUBLESHOOTING

Engine temperature too high

- Faulty temperature gauge or ECT sensor
- Thermostat stuck closed
- Faulty radiator cap
- Insufficient coolant
- Passage blocked in radiator, hoses or water jacket
- Air in system
- Faulty cooling fan motor
- Faulty fan control relay
- Faulty water pump

Engine temperature too low

- Faulty temperature gauge or ECT sensor
- Thermostat stuck open
- Faulty cooling fan control relay

Coolant leak

- Faulty water pump mechanical seal
- Deteriorated O-rings
- Faulty radiator cap
- Damaged or deteriorated cylinder head gasket
- Loose hose connection or clamp
- Damaged or deteriorated hose

SYSTEM TESTING

COOLANT (HYDROMETER TEST)

Remove the following:

- Lower cowls (page 3-6)
- Middle cowls (page 3-7)
- Upper cowl (page 3-9)

Remove the radiator cap.

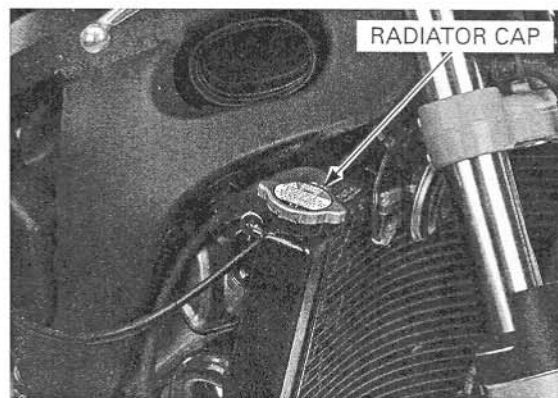

Test the coolant gravity using a hydrometer (see below for "Coolant gravity chart").

For maximum corrosion protection, a 1:1 solution of ethylene glycol and distilled water is recommended (page 7-3).

Look for contamination and replace the coolant if necessary.

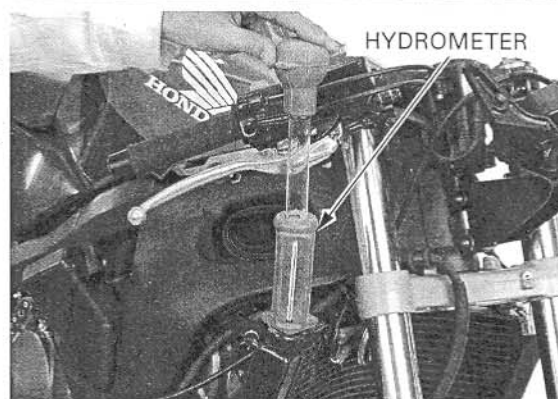

COOLANT GRAVITY CHART

		Coolant temperature °C (°F)										
		0 (32)	5 (41)	10 (50)	15 (59)	20 (68)	25 (77)	30 (86)	35 (95)	40 (104)	45 (113)	50 (122)
Coolant ratio%	5	1.009	1.009	1.008	1.008	1.007	1.006	1.005	1.003	1.001	0.999	0.997
	10	1.018	1.017	1.017	1.016	1.015	1.014	1.013	1.011	1.009	1.007	1.005
	15	1.028	1.027	1.026	1.025	1.024	1.022	1.020	1.018	1.016	1.014	1.012
	20	1.036	1.035	1.034	1.033	1.031	1.029	1.027	1.025	1.023	1.021	1.019
	25	1.045	1.044	1.043	1.042	1.040	1.038	1.036	1.034	1.031	1.028	1.025
	30	1.053	1.052	1.051	1.047	1.046	1.045	1.043	1.041	1.038	1.035	1.032
	35	1.063	1.062	1.060	1.058	1.056	1.054	1.052	1.049	1.046	1.043	1.040
	40	1.072	1.070	1.068	1.066	1.064	1.062	1.059	1.056	1.053	1.050	1.047
	45	1.080	1.078	1.076	1.074	1.072	1.069	1.066	1.063	1.060	1.057	1.054
	50	1.086	1.084	1.082	1.080	1.077	1.074	1.071	1.068	1.065	1.062	1.059
	55	1.095	1.093	1.091	1.088	1.085	1.082	1.079	1.076	1.073	1.070	1.067
60	1.100	1.098	1.095	1.092	1.089	1.086	1.083	1.080	1.077	1.074	1.071	

COOLING SYSTEM

RADIATOR CAP/SYSTEM PRESSURE INSPECTION

Remove the radiator cap (page 7-5).

Before installing the cap in the tester, wet the sealing surfaces.

Pressure test the radiator cap. Replace the radiator cap if it does not hold pressure, or if relief pressure is too high or too low. It must hold specified pressure for at least 6 seconds.

RADIATOR CAP RELIEF PRESSURE:

108 – 137 kPa (1.1 – 1.4 kgf/cm², 16 – 20 psi)

Pressure the radiator, engine and hoses, and check for leaks.

NOTICE

Excessive pressure can damage the cooling system components. Do not exceed 137 kPa (1.4 kgf/cm², 20 psi).

Repair or replace components if the system will not hold specified pressure for at least 6 seconds.

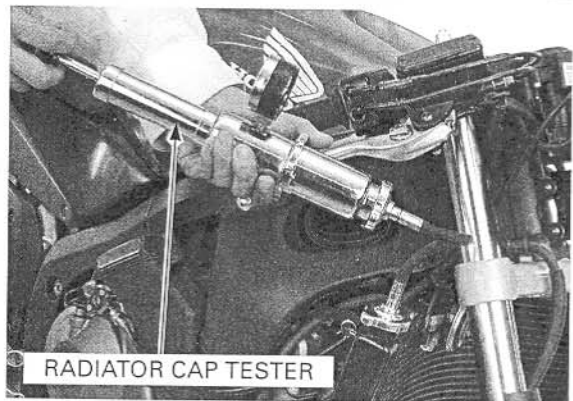
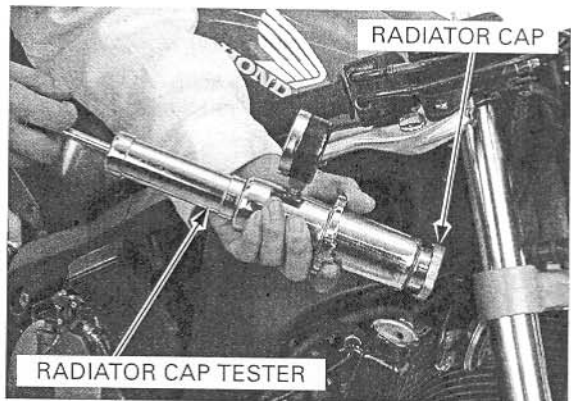

COOLANT REPLACEMENT

PREPARATION

- The effectiveness of coolant decreases with the accumulation of rust or if there is a change in the mixing proportion during usage. Therefore, for best performance change the coolant regularly as specified in the maintenance schedule.
- Mix only distilled, low mineral water with the antifreeze.

RECOMMENDED ANTIFREEZE:

Pro Honda HP Coolant or an equivalent high quality ethylene glycol antifreeze containing corrosion protection inhibitors

RECOMMENDED MIXTURE:

1:1 (Distilled water and antifreeze)

REPLACEMENT/AIR BLEEDING

Remove the following:

- Lower cowls (page 3-6)
- Middle cowls (page 3-7)
- Upper cowl (page 3-9)

Remove the radiator cap.

When filling the system or reserve tank with a coolant (checking coolant level), place the motorcycle in a vertical position on a flat, level surface.

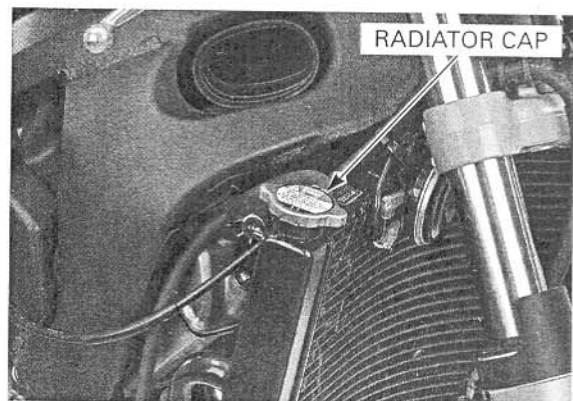
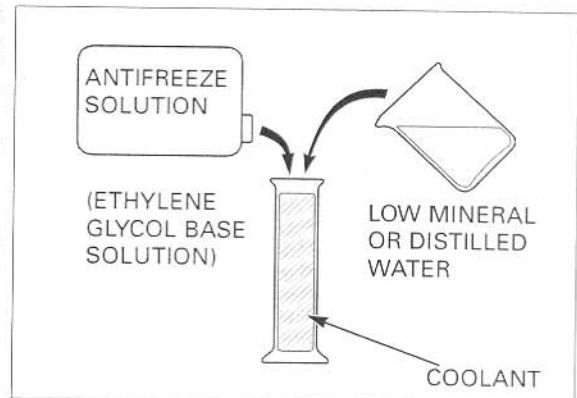

COOLING SYSTEM

Remove the drain bolt on the water pump cover and drain the system coolant.

Remove the cylinder drain bolt and drain the coolant from the cylinder.

Reinstall the drain bolts with new sealing washers. Tighten the cylinder drain bolt securely. Tighten the water pump drain bolt to the specified torque.

TORQUE: 12 N·m (1.2 kgf·m, 9 lbf·ft)

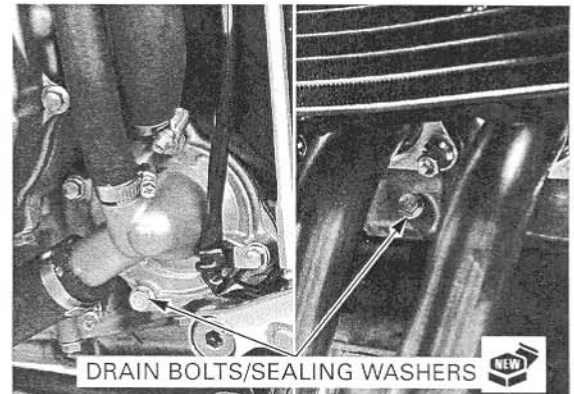

Disconnect the siphon hose from the radiator.

Drain the reserve tank coolant. Empty the coolant and rinse the inside of the reserve tank with water.

Connect the radiator siphon hose.

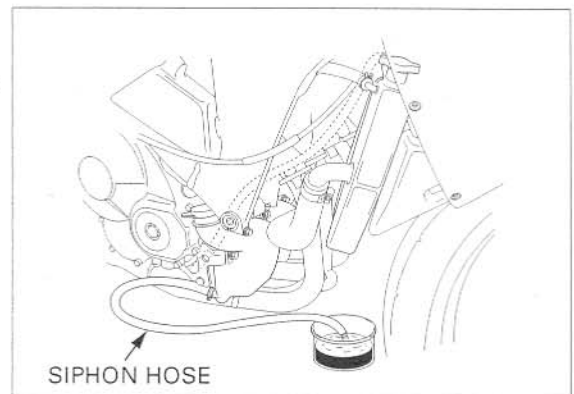

Fill the system with the recommended coolant through the filler opening up to filler neck.

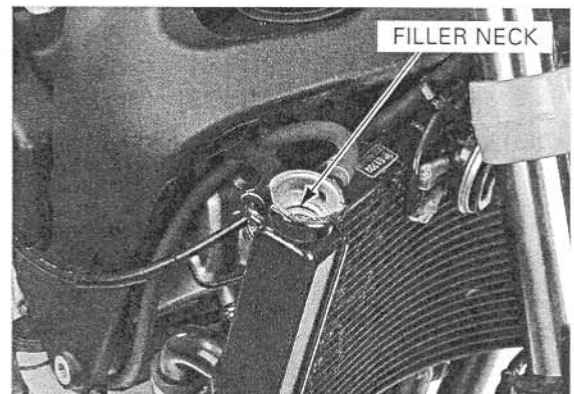

Remove the radiator reserve tank cap and fill the reserve tank to the upper level line.

Bleed air from the system as follows:

1. Shift the transmission into neutral. Start the engine and let it idle for 2 – 3 minutes.
2. Snap the throttle three to four times to bleed air from the system.
3. Stop the engine and add coolant up to the proper level if necessary. Reinstall the radiator cap.
4. Check the level of coolant in the reserve tank and fill to the upper level if it is low.

Install the radiator reserve tank cap.

Install the following:

- Upper cowls (page 3-12)
- Middle cowls (page 3-8)
- Lower cowls (page 3-6)

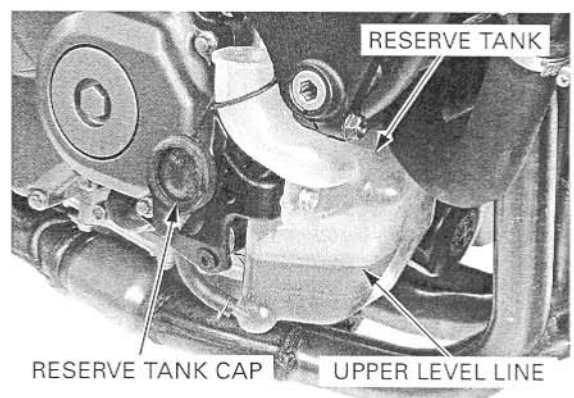

COOLING SYSTEM

THERMOSTAT

REMOVAL

Drain the coolant (page 7-6).

Remove the throttle body (page 6-72).

Remove the bolts and thermostat housing cover.

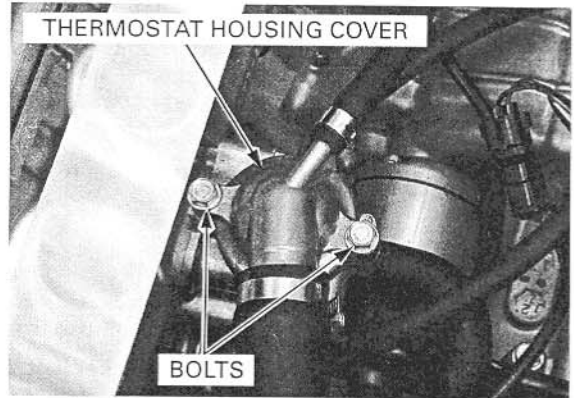

Remove the thermostat from the housing.

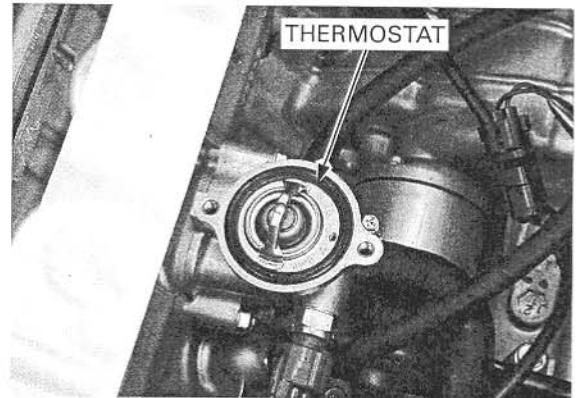

INSPECTION

Wear insulated gloves and adequate eye protection. Keep flammable materials away from the electric heating element.

Visually inspect the thermostat for damage. Check for damage of the seal ring.

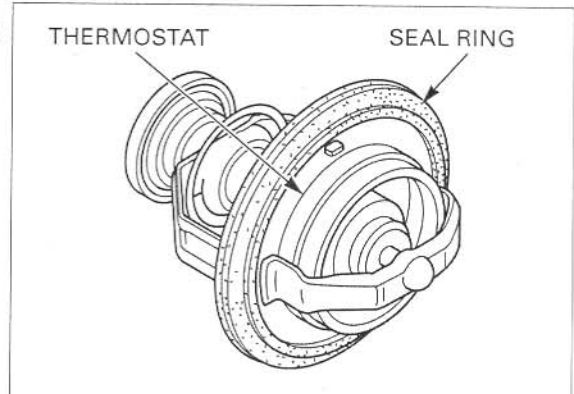

Do not let the thermostat or thermometer touch the pan, or you will get false reading.

Heat the water with an electric heating element to operating temperature for 5 minutes. Suspend the thermostat in heated water to check its operation.

Replace the thermostat if the valve stays open at room temperature, or if it responds at temperatures other than those specified.

THERMOSTAT BEGIN TO OPEN:

80 – 84 °C (176 – 183 °F)

VALVE LIFT:

8 mm (0.3 in) minimum at 90 °C (194 °F)

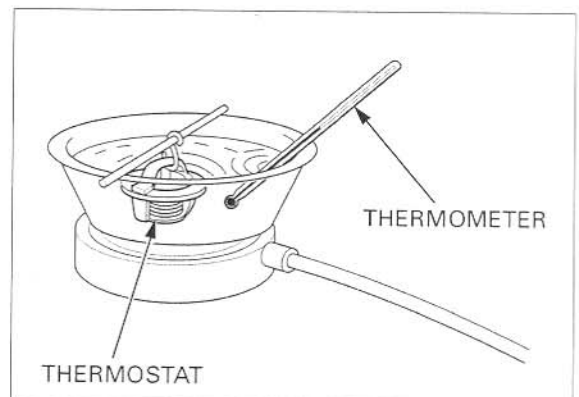

THERMOSTAT HOUSING REMOVAL

Disconnect the ECT sensor connector.
 Disconnect the fast idle wax unit water hose and bypass hose from the thermostat housing.

Remove the bolts and thermostat housing from the cylinder head.

Remove the O-ring from the housing.

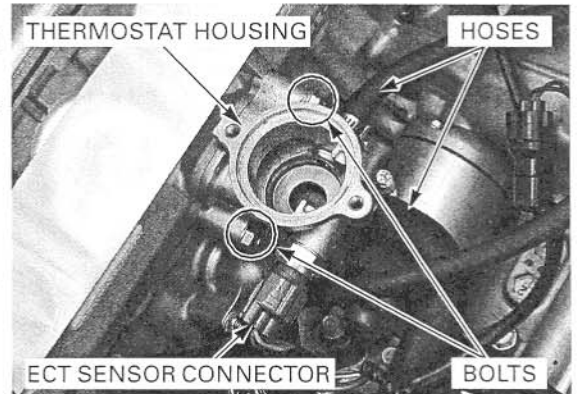

THERMOSTAT HOUSING INSTALLATION

Install a new O-ring into the groove of the thermostat housing.

Install the thermostat housing onto the cylinder head.

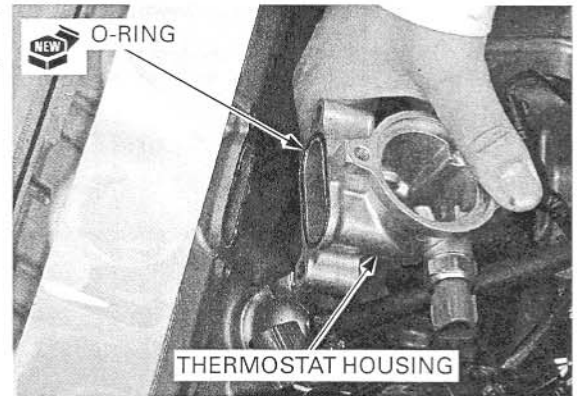

Install and tighten the thermostat housing mounting bolts securely.

Connect the fast idle wax unit water hose and bypass hose.

Connect the ECT sensor connector.

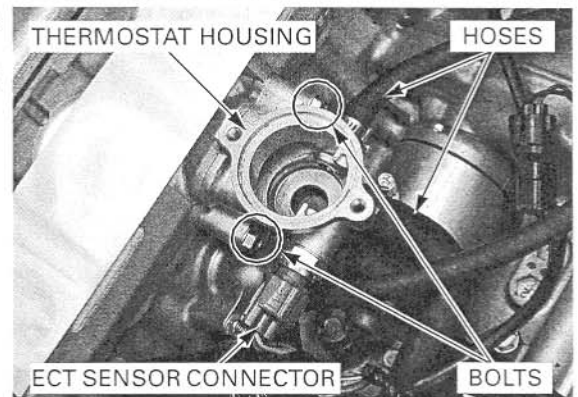

THERMOSTAT INSTALLATION

Install the thermostat into the housing with its air bleed hole facing rearward.

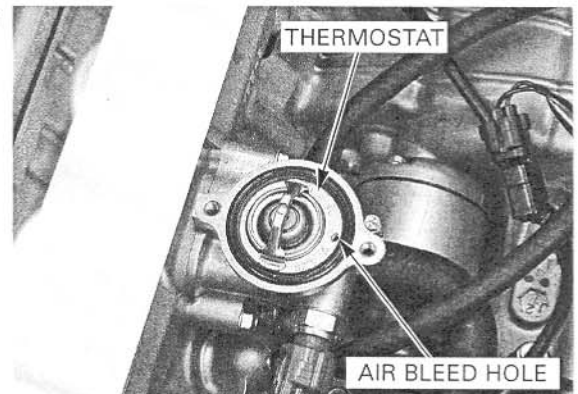

COOLING SYSTEM

Install the thermostat housing cover onto the housing.

Install and tighten the housing cover bolts to the specified torque.

TORQUE: 13 N·m (1.3 kgf·m, 10 lbf·ft)

Fill the system with the recommended coolant and bleed any air (page 7-6).

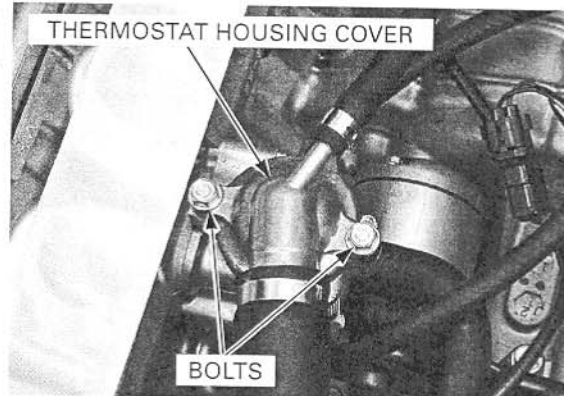

RADIATOR

REMOVAL

Remove the following:

- Lower cowls (page 3-6)
- Middle cowls (page 3-7)
- Upper cowl (page 3-9)

Drain the coolant (page 7-6).

Disconnect the siphon hose and air bleed hose from the radiator.

Loosen the hose clamp screw and disconnect the lower radiator hose.

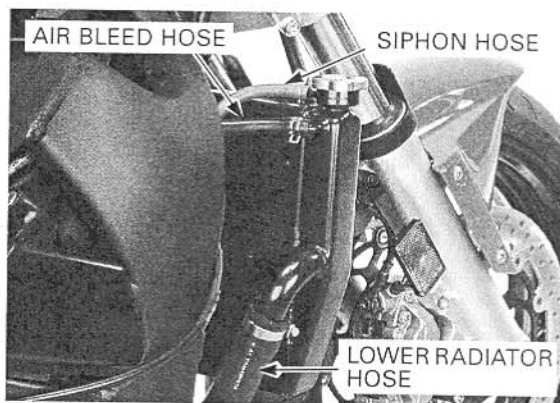

Loosen the hose clamp screw and disconnect the upper radiator hose.

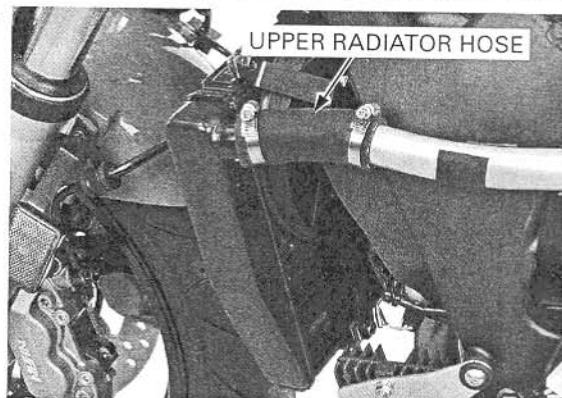

Disconnect the fan motor 2P (Black) connector.

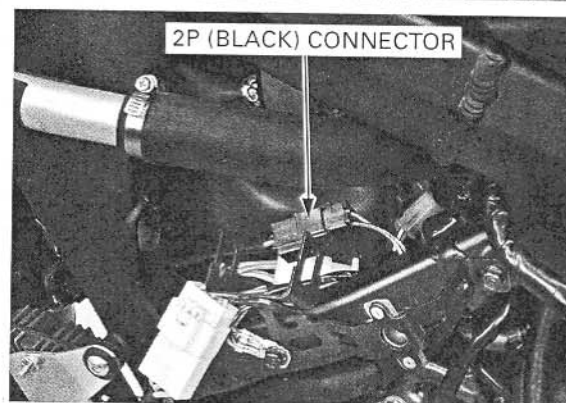

COOLING SYSTEM

Remove the radiator lower mounting bolt/nut and washer.

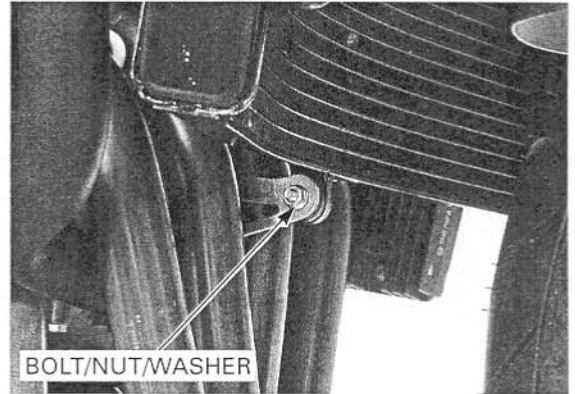

Remove the wire band.

Remove the radiator upper mounting bolt, washer and horn mounting stay.

Be careful not to damage the radiator fins.

Release the radiator upper grommet from the frame boss by moving the radiator to the left, then remove the radiator assembly.

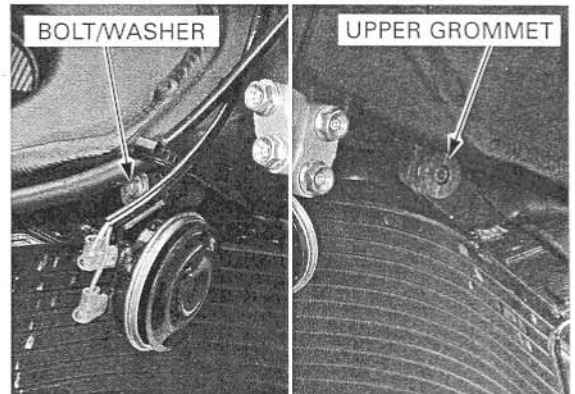

DISASSEMBLY

Remove the three bolts and cooling fan motor assembly from the radiator.

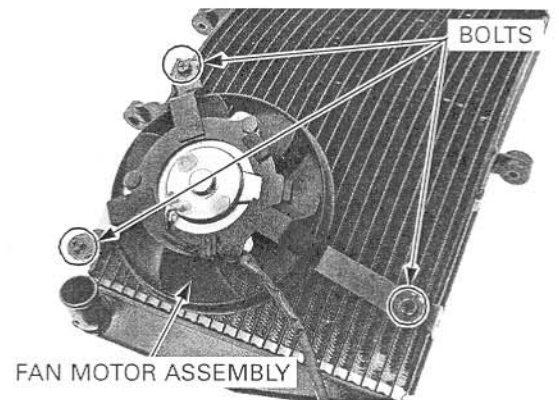

Remove the nut and cooling fan.

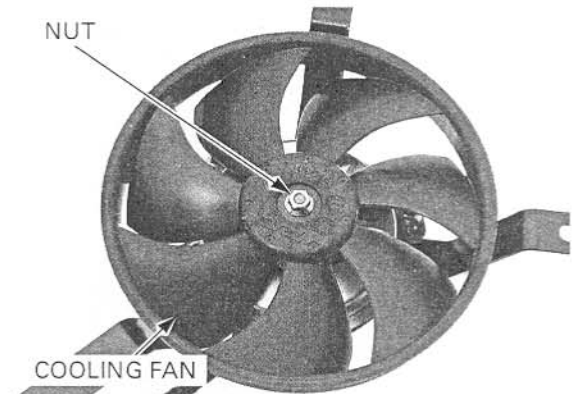

COOLING SYSTEM

Remove the nuts and fan motor from the fan motor shroud.

Refer to the fan control relay information (page 7-18).

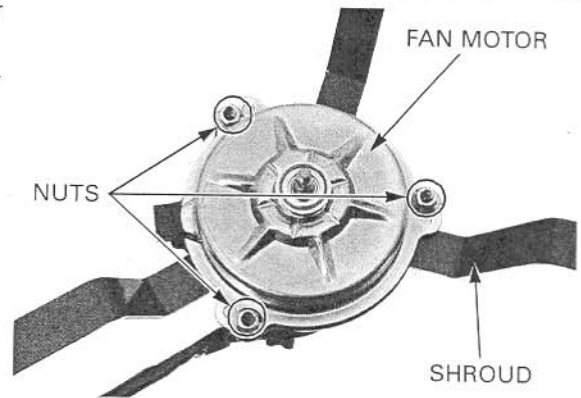

ASSEMBLY

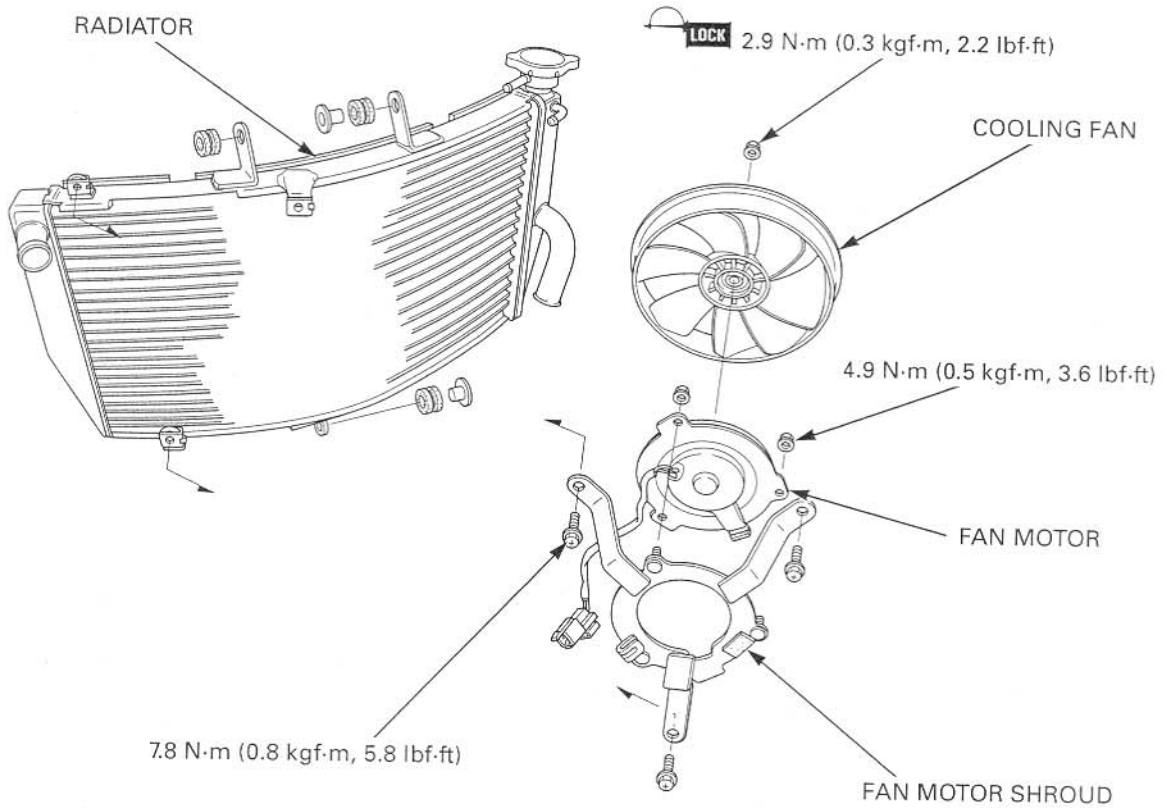

Install the fan motor onto the fan motor shroud and tighten the nuts to the specified torque.

TORQUE: 4.9 N·m (0.5 kgf·m, 3.6 lbf·ft)

Install the fan motor wire onto the wire clamp.

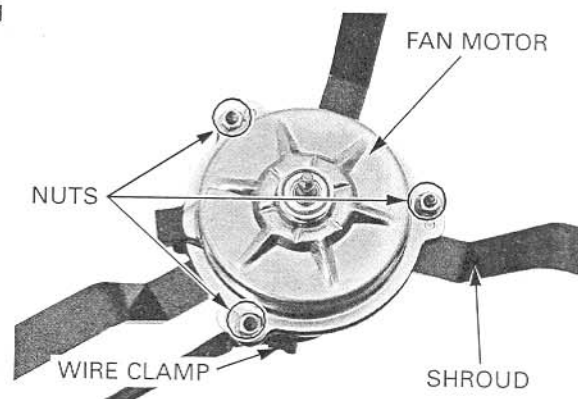

COOLING SYSTEM

Install the cooling fan onto the fan motor shaft by aligning the flat surfaces.

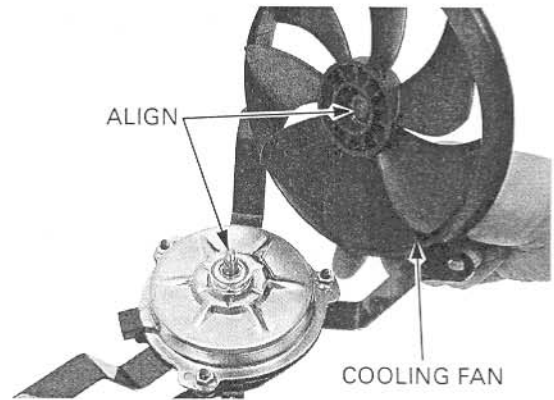

Apply a locking agent to the cooling fan nut threads. Install and tighten the nut to the specified torque.

TORQUE: 2.9 N·m (0.3 kgf·m, 2.2 lbf·ft)

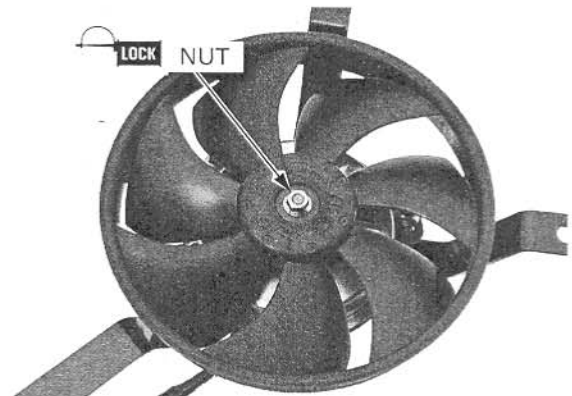

Install the fan motor assembly onto the radiator. Install and tighten the three bolts to the specified torque.

TORQUE: 7.8 N·m (0.8 kgf·m, 5.8 lbf·ft)

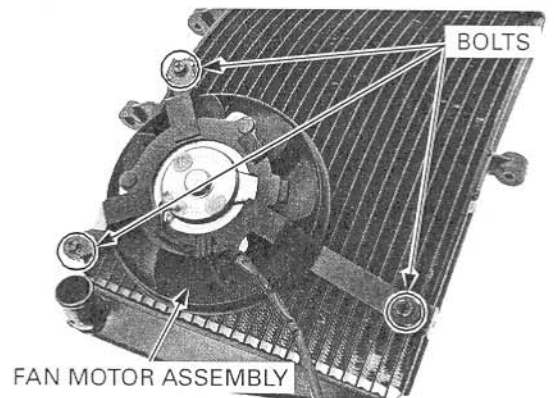

INSTALLATION

Be careful not to damage the radiator fins.

Install the radiator assembly, aligning its upper grommet with the frame boss.

Install the washer, horn mounting stay and upper mounting bolt, then tighten the bolt.

Install the wire band.

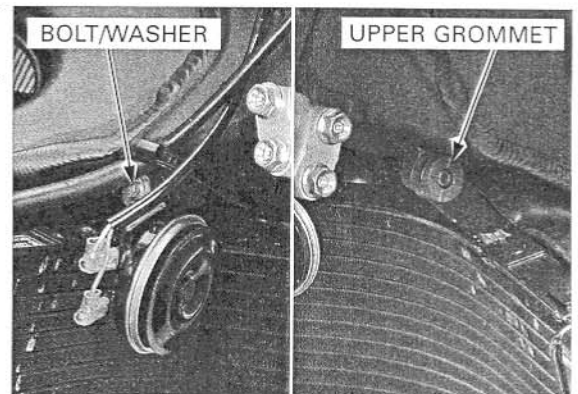

COOLING SYSTEM

Install the radiator lower mounting bolt, washer, nut and tighten the nut securely.

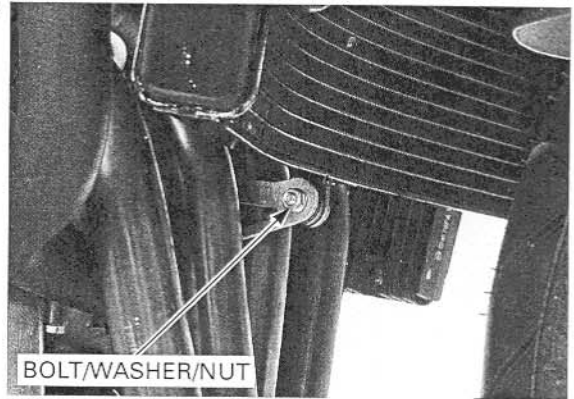

Connect the fan motor 2P (Black) connector.

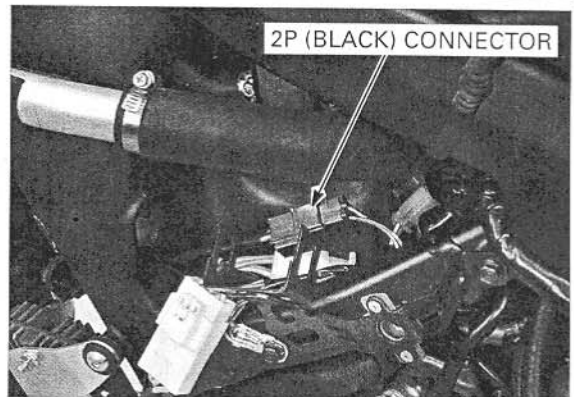

Connect the upper radiator hose and tighten the hose clamp screw.

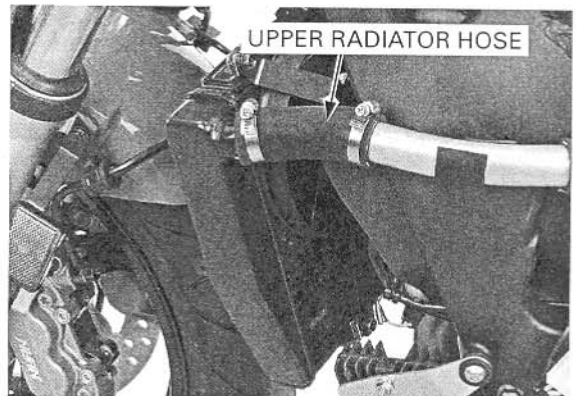

Connect the radiator hose and tighten the hose clamp screw.
Connect the siphon hose and air bleed hose to the radiator.

Fill the system with the recommended coolant (page 7-6).

Install the following:

- Upper cowl (page 3-12)
- Middle cowls (page 3-8)
- Lower cowls (page 3-6)

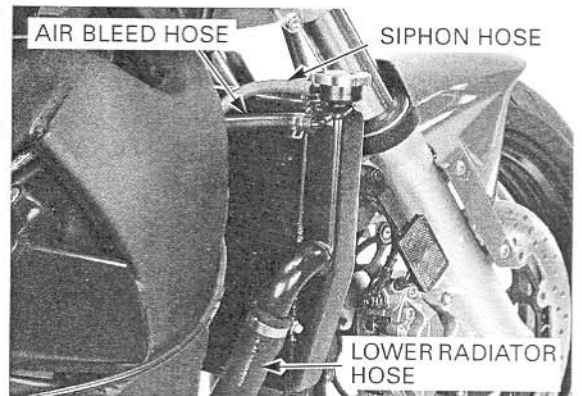

WATER PUMP

MECHANICAL SEAL INSPECTION

Remove the lower cowls (page 3-6).

Inspect the inspection hole for signs of coolant leakage.

If there is leakage, the mechanical seal is defective and replace the water pump as an assembly.

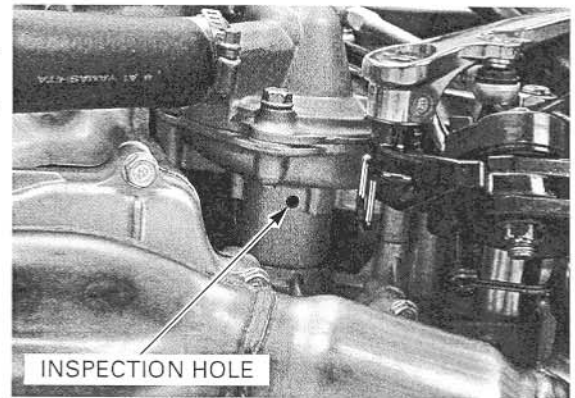

REMOVAL

Drain the coolant (page 7-6).

Disconnect the radiator hose, bypass hose and water hose from the water pump cover.

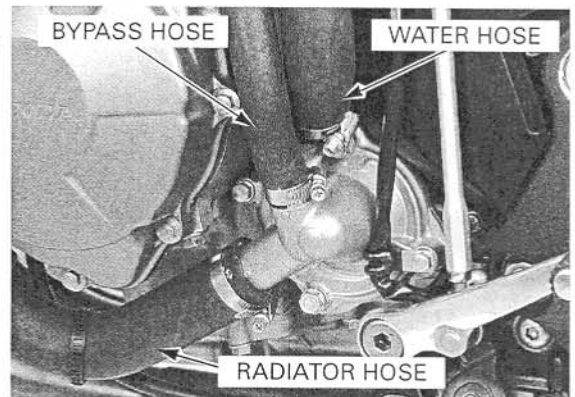

Remove the two SH bolts and clamp, two flange bolts with two sealing washers and water pump cover.

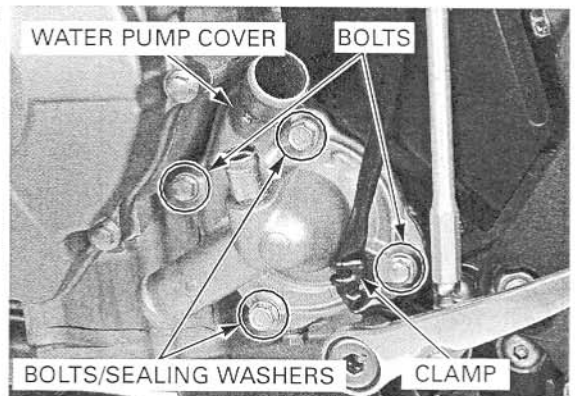

Remove the O-ring from the water pump body.

Remove the water pump body from the crankcase.

NOTE:

Do not disassemble the water pump body.

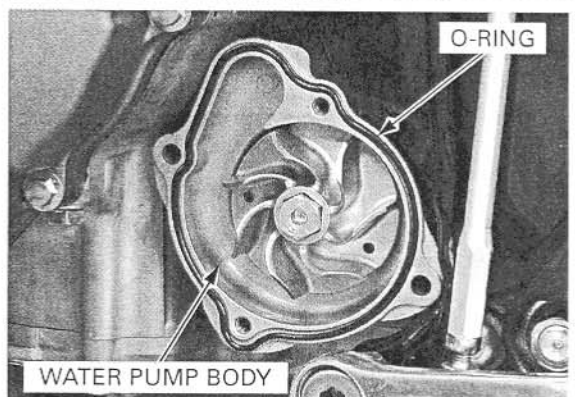

COOLING SYSTEM

INSTALLATION

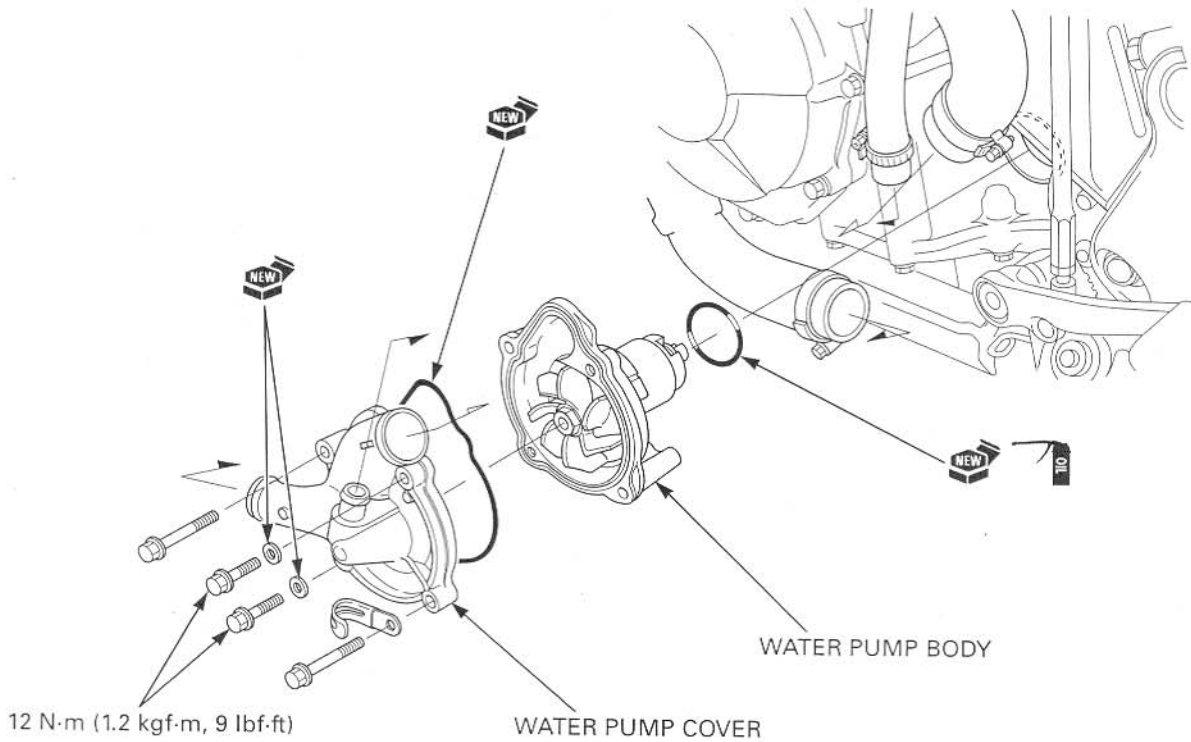

Apply engine oil to a new O-ring and install it onto the stepped portion of the water pump body.

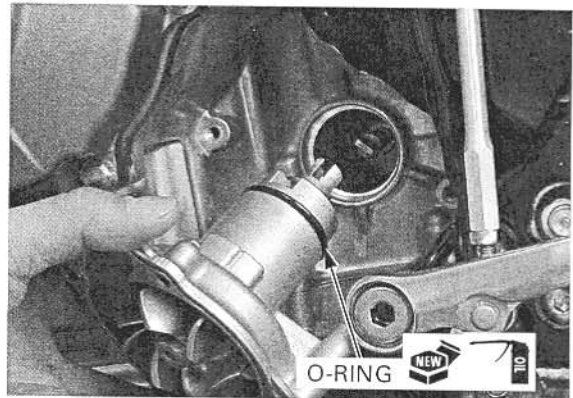

Install the water pump body into the crankcase while aligning the water pump shaft groove with the oil pump shaft end by turning the water pump impeller.

Align the mounting bolt holes in the water pump and crankcase and make sure the water pump is securely installed.

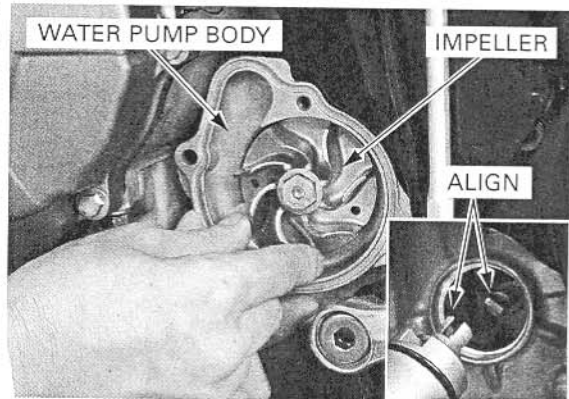

Install a new O-ring into the groove in the water pump body.

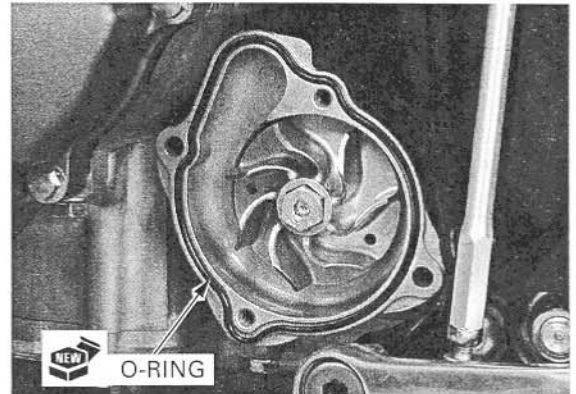

Install the water pump cover, new two sealing washers with two flange bolts and two SH bolts, clamp. Tighten the flange bolts to the specified torque.

TORQUE: 12 N·m (1.2 kgf·m, 9 lbf·ft)

Tighten the two SH bolts securely.

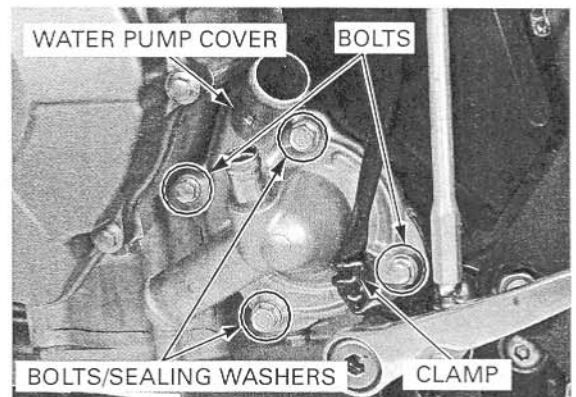

Connect the radiator hose, water hose and bypass hose, then tighten the clamp screws.

Fill the system with the recommended coolant (page 7-6).

Install the lower cowls (page 3-6).

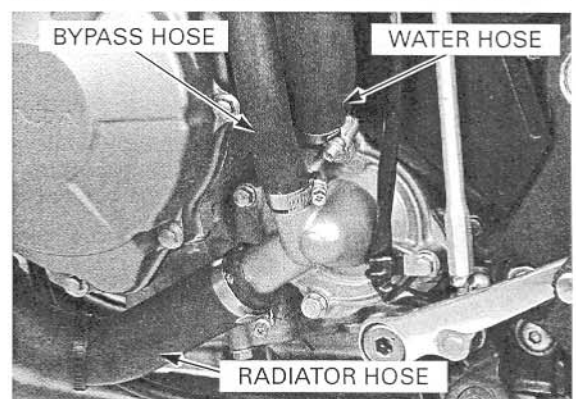

RADIATOR RESERVE TANK

REMOVAL

Remove the following:

- Lower cowls (page 3-6)
- Middle cowls (page 3-7)

Disconnect the siphon hose and drain the coolant from the reserve tank.

Remove the bolt and radiator reserve tank.

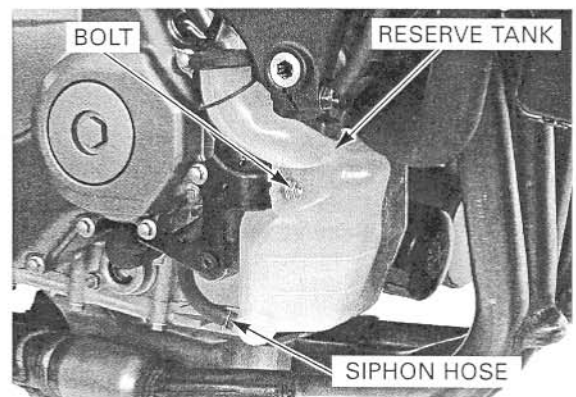

COOLING SYSTEM

INSTALLATION

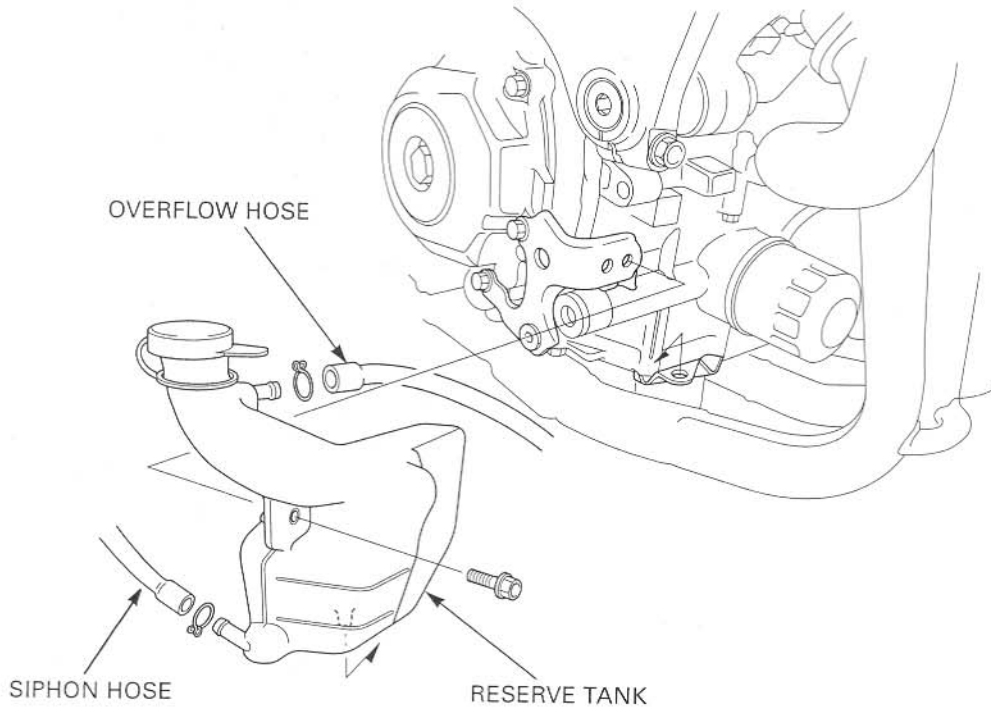

Connect the siphon hose to the reserve tank.

Install the reserve tank while aligning the boss of reserve tank with the mounting stay hole. Install and tighten the bolt securely.

Fill the system with the recommended coolant (page 7-6).

Install the following:

- Middle cowls (page 3-8)
- Lower cowls (page 3-6)

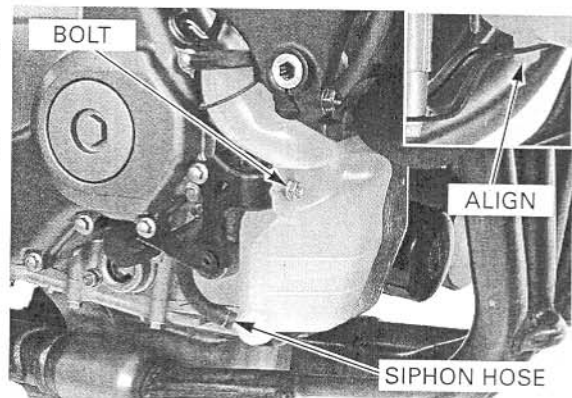

FAN CONTROL RELAY

INSPECTION

Remove the following:

- Lower cowls (page 3-6)
- Middle cowls (page 3-7)

Disconnect the fan control relay connector. Remove the fan control relay.

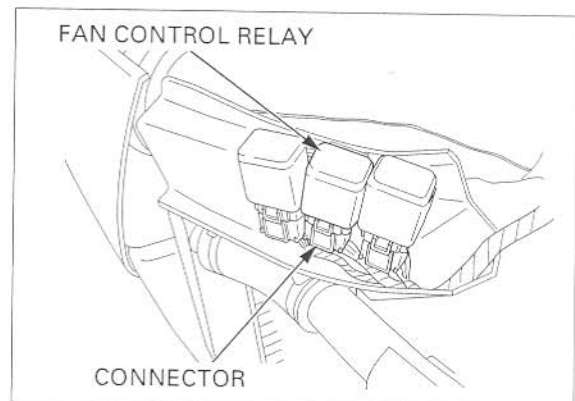

COOLING SYSTEM

Connect the ohmmeter to the fan control relay connector terminals.

CONNECTION: Blue/orange – Black/blue

Connect the 12V battery to the following fan control relay connector terminals.

CONNECTION: Green/blue – Black/white

There should be continuity only when 12V battery is connected.

If there is no continuity only when the 12V battery is connected, replace the fan control relay.

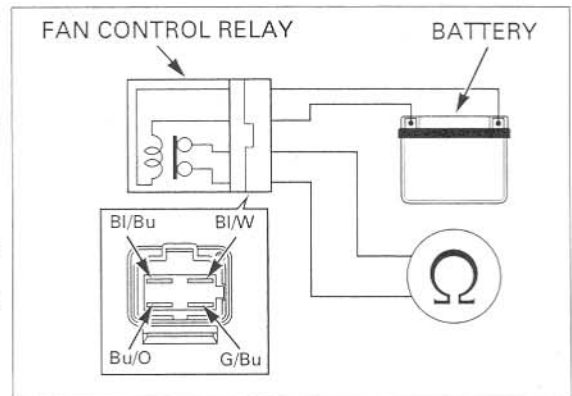

8. ENGINE REMOVAL/INSTALLATION

COMPONENT LOCATION	8-2	ENGINE REMOVAL	8-5
SERVICE INFORMATION	8-3	ENGINE INSTALLATION.....	8-10

ENGINE REMOVAL/INSTALLATION

COMPONENT LOCATION

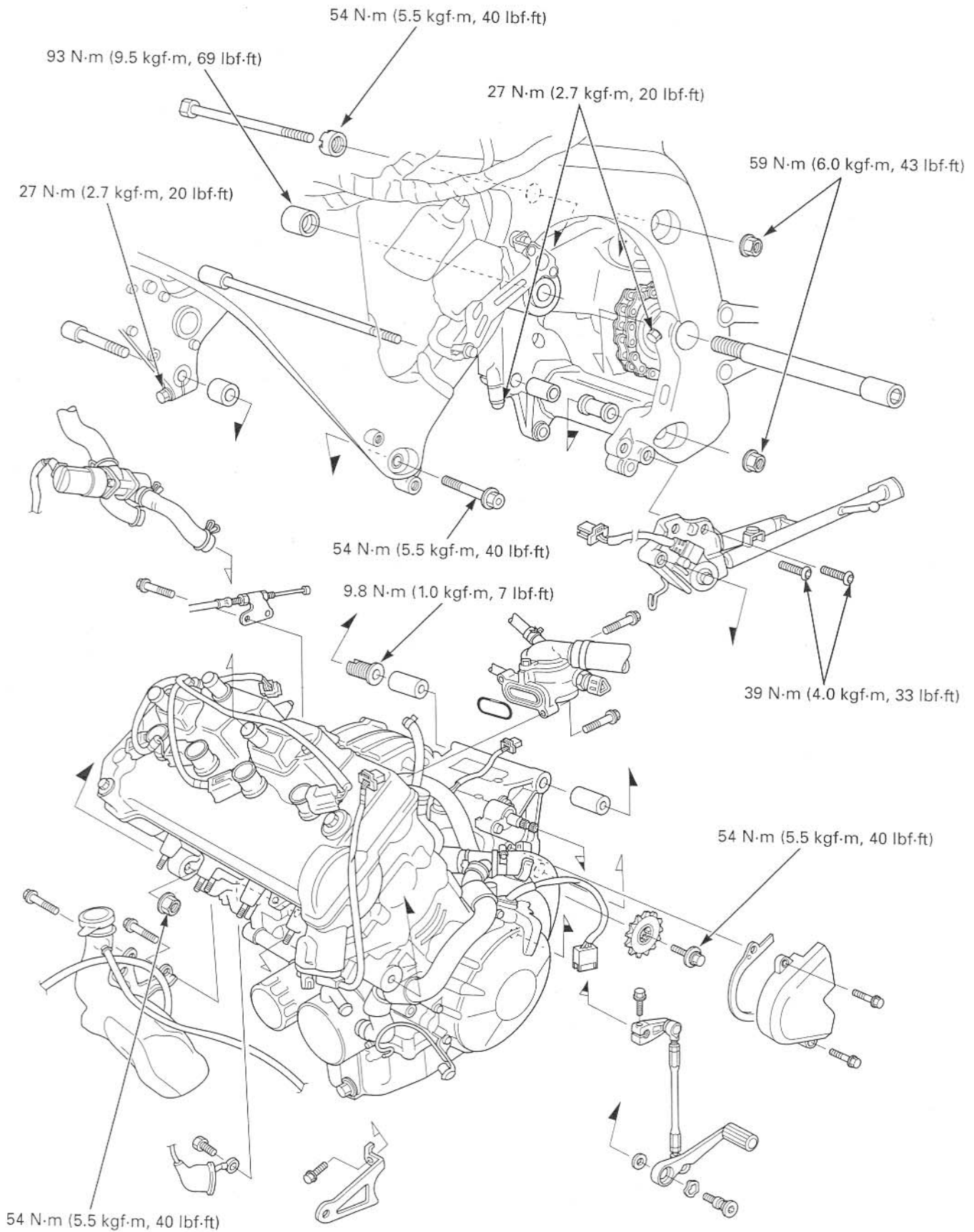

SERVICE INFORMATION

GENERAL

- A hoist or equivalent is required to support the motorcycle when removing and installing the engine.
- A floor jack or other adjustable support is required to support and maneuver the engine.
- Do not use the oil filter and oil cooler as a jacking point.
- When using the lock nut wrench for the adjusting bolt lock nut, use a deflecting beam type torque wrench 20 inches long. The lock nut wrench increases the torque wrench's leverage, so the torque wrench reading will be less than the torque actually applied to the lock nut. The specification given is the actual torque applied to the lock nut, not the reading on the torque wrench. Do not overtighten the lock nut. The specification later in the text gives both actual and indicated.
- The following components can be serviced with the engine installed in the frame.
 - Alternator (page 11-4)
 - Clutch (page 10-7)
 - Camshaft (page 9-8)
 - Gearshift linkage (page 10-22)
 - Oil cooler (page 5-12)
 - Oil pump (page 5-8)
 - Water pump (page 7-15)
- The following components require engine removal for service.
 - Cylinder head (page 9-13)
 - Crankshaft (page 13-5)
 - Piston/cylinder (page 13-13)
 - Shift fork/shift drum/Transmission (page 12-7)
- When installing the engine, be sure to tighten the engine mounting fasteners to the specified torque in the specified sequence. If you mistake the torque or sequence, loosen all mounting fasteners, then tighten them again to the specified torque in the correct sequence.

SERVICE DATA

ITEM		SPECIFICATIONS
Engine dry weight		58.3 kg (128.5 lbs)
Engine oil capacity	After disassembly	3.5 liter (3.7 US qt, 3.1 Imp qt)
Coolant capacity	Radiator and engine	3.2 liter (3.4 US qt, 2.8 Imp qt)

TORQUE VALUES

Front engine hanger bolt (left side)	54 N·m (5.5 kgf·m, 40 lb·ft)	
Front engine hanger nut (right side)	54 N·m (5.5 kgf·m, 40 lb·ft)	
Front engine hanger pinch bolt	27 N·m (2.7 kgf·m, 20 lbf·ft)	
Rear engine hanger adjusting bolt	9.8 N·m (1.0 kgf·m, 7 lbf·ft)	
Rear engine hanger lock nut	54 N·m (5.5 kgf·m, 40 lb·ft)	
Rear engine hanger nut	59 N·m (6.0 kgf·m, 43 lbf·ft)	
Lower engine hanger pinch bolt	27 N·m (2.7 kgf·m, 20 lbf·ft)	
Lower engine hanger nut	59 N·m (6.0 kgf·m, 43 lbf·ft)	
Swingarm pivot pinch bolt	27 N·m (2.7 kgf·m, 20 lbf·ft)	
Swingarm pivot nut	93 N·m (9.5 kgf·m, 69 lbf·ft)	
Drive sprocket special bolt	54 N·m (5.5 kgf·m, 40 lb·ft)	
Starter motor terminal nut	12 N·m (1.2 kgf·m, 9 lbf·ft)	
Side stand bracket socket bolt	39 N·m (4.0 kgf·m, 33 lbf·ft)	ALOC bolt
Oil pressure switch wire terminal screw	2.0 N·m (0.2 kgf·m, 1.4 lbf·ft)	

ENGINE REMOVAL/INSTALLATION

TOOLS

Lock nut wrench
07VMA-MBB0100

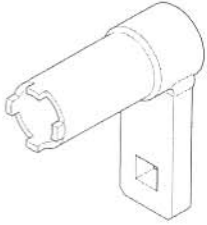

or 07VMA-MBB0101

ENGINE REMOVAL

Remove the following:

- Lower cowls (page 3-6)
- Middle cowls (page 3-7)
- Exhaust pipe (page 3-24)
- Fuel tank (page 6-61)
- Radiator (page 7-10)
- Radiator reserve tank (page 7-17)
- Air cleaner housing (page 6-64)
- Throttle body (page 6-72)
- Regulator/rectifier (page 17-11)

Remove the pinch bolt and disconnect the gear shift arm from the gear shift spindle.

Remove the bolt, washer, wave washer and gear shift pedal assembly.

Remove the two bolts, drive sprocket cover and guide plate.

Loosen the rear axle nut.

Turn the drive chain adjusting bolts make the drive chain slack fully.

Remove the drive sprocket special bolt, washer and drive sprocket.

Disconnect the following:

- Neutral switch connector
- Side stand switch 2P (Green) connector
- Cam pulse generator 2P (Natural) connector

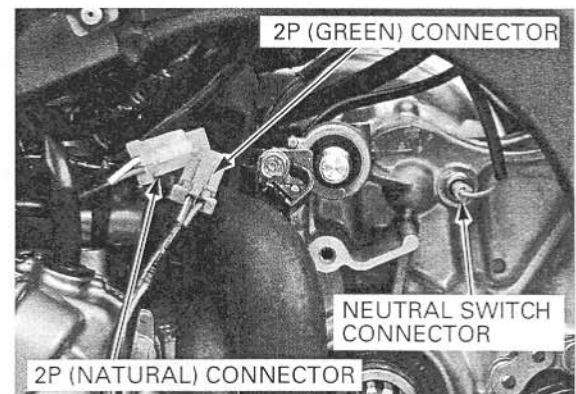
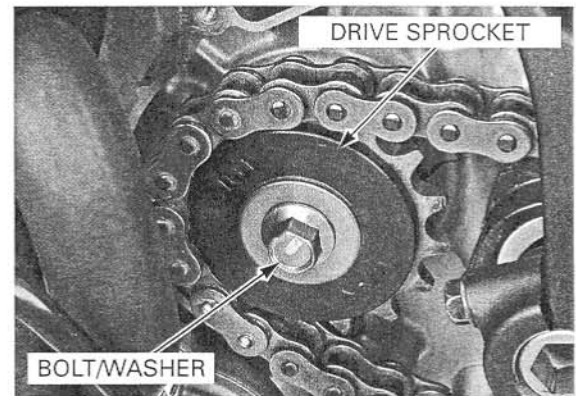
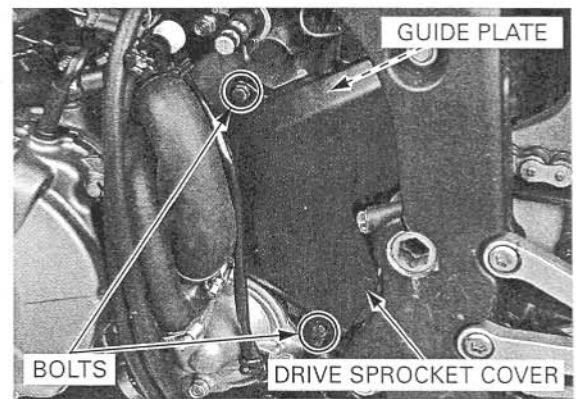
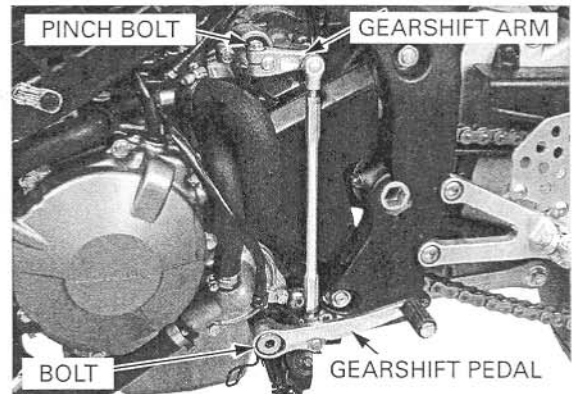

ENGINE REMOVAL/INSTALLATION

Loosen the hose clamp screw and disconnect the radiator hose from the water pump. Loosen the hose clamp screws and disconnect the water hoses from the oil cooler.

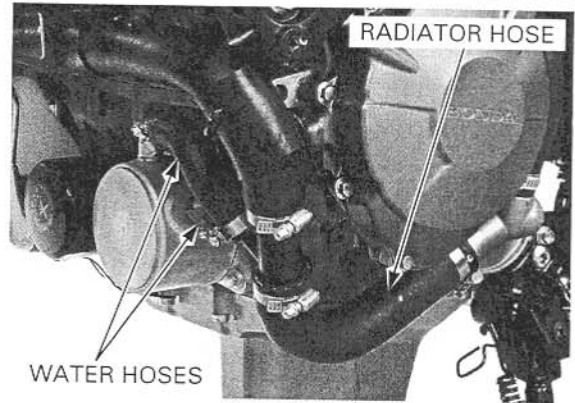

Remove the bolt, clutch cable guide plate, then disconnect the clutch cable from the clutch lifter lever.

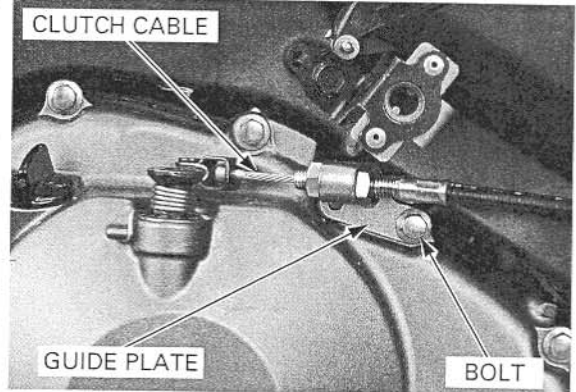

Remove the radiator reserve tank (page 7-17). Remove the dust cover, terminal screw and oil pressure wire terminal. Remove the bolt and radiator bracket.

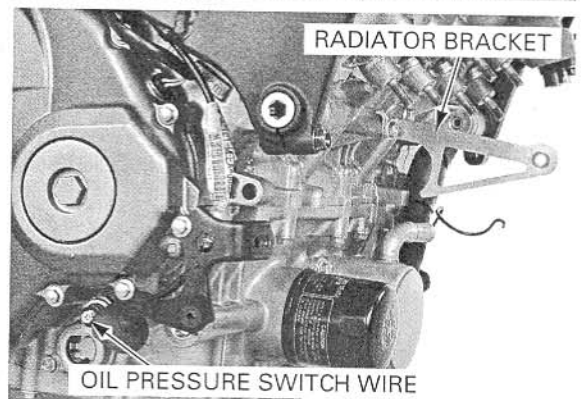

Disconnect the ignition pulse generator 2P (Red) connector.

Disconnect the ECT sensor connector and vehicle speed sensor 3P (Natural) connector.

Remove the thermostat housing from the crankcase (page 7-9).

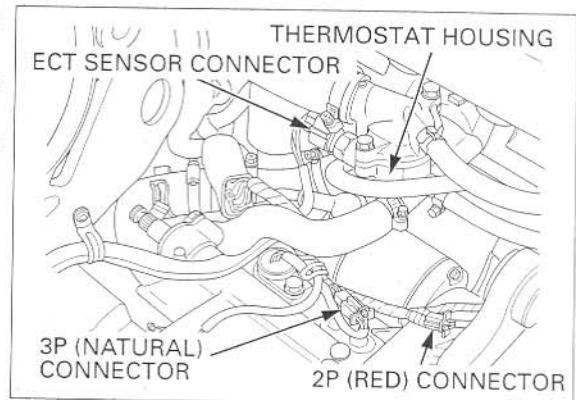

ENGINE REMOVAL/INSTALLATION

Remove the nut and disconnect the starter motor cable from the starter motor.

Remove the starter motor mounting bolts and disconnect the ground cable.

Pull the starter motor out of the crankcase.

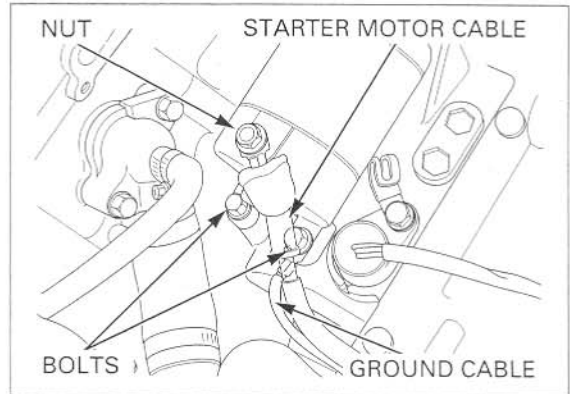

Remove the crankcase breather hose from the cylinder head.

Disconnect the PAIR control solenoid valve 2P (Black) connector.

Disconnect the PAIR air hoses from the cylinder head and remove the PAIR control solenoid valve.

Remove the heat guard rubber.

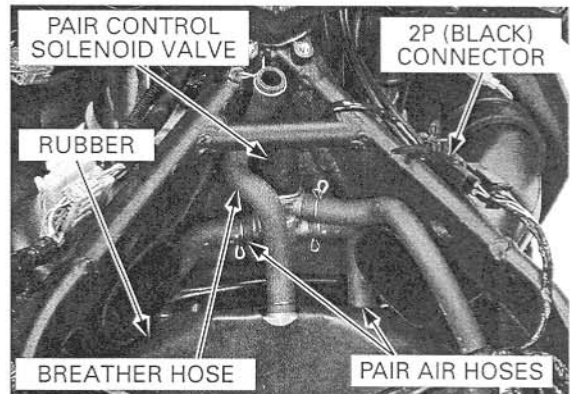

Disconnect the direct ignition coil 6P (Black) connector.

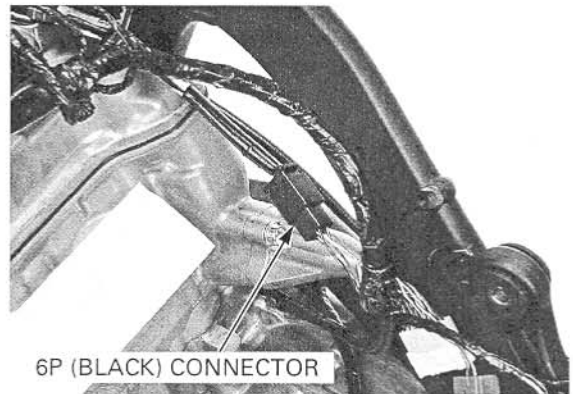

Remove the socket bolts and side stand bracket assembly.

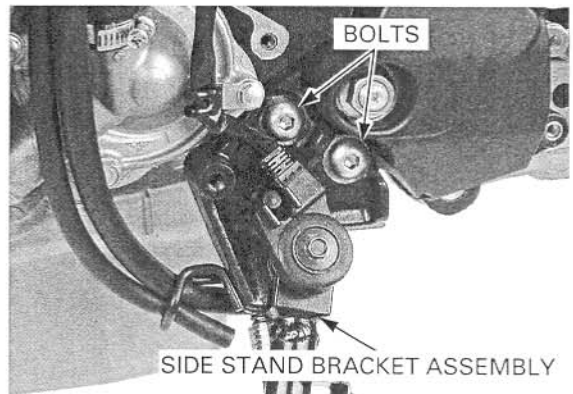

ENGINE REMOVAL/INSTALLATION

Loosen the pinch bolts and remove the swingarm pivot nut while holding the swingarm pivot shaft.

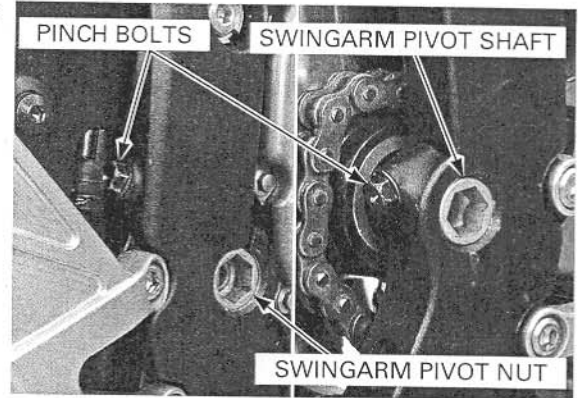

Loosen the lower engine hanger pinch bolt.

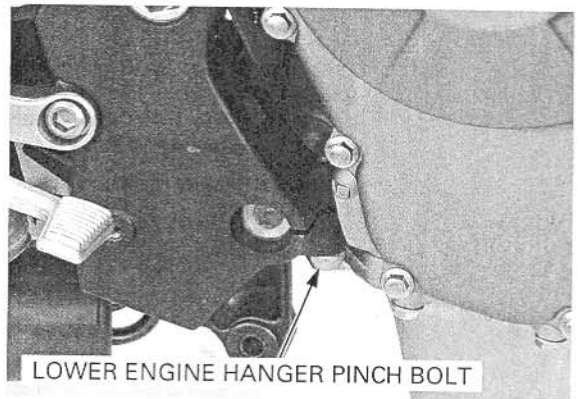

Loosen the front engine hanger pinch bolt. Remove the right side front engine hanger bolt, nut and collar.

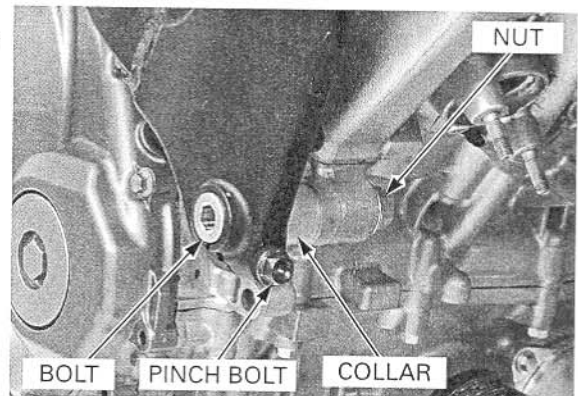

Remove the left side front engine hanger bolt.

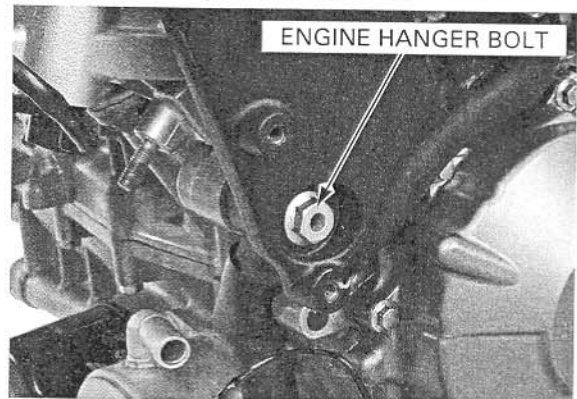

ENGINE REMOVAL/INSTALLATION

Remove the rear engine hanger nut.

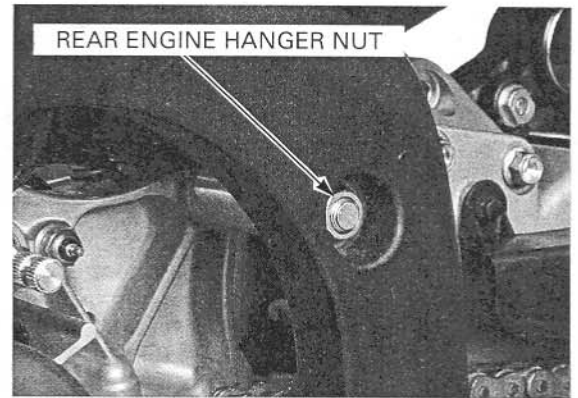

Remove the rear engine hanger lock nut using the special tool.

TOOL:
Lock nut wrench

07VMA-MBB0100 or
07VMA-MBB0101

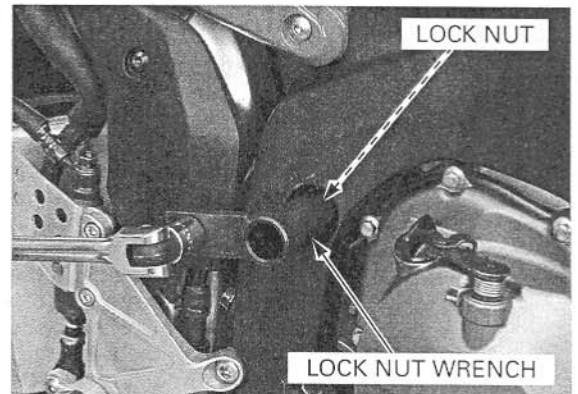

Turn the engine hanger adjusting bolt counterclockwise fully by loosening the rear engine hanger bolt.

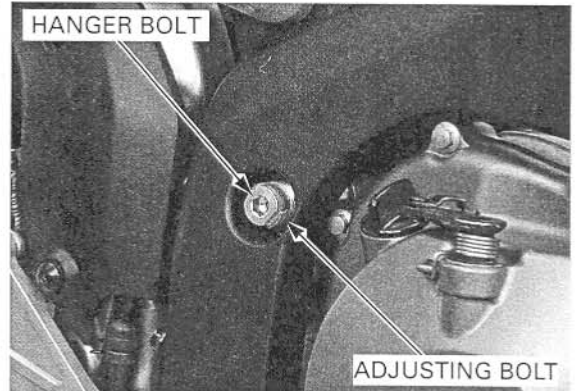

Remove the lower engine hanger nut.

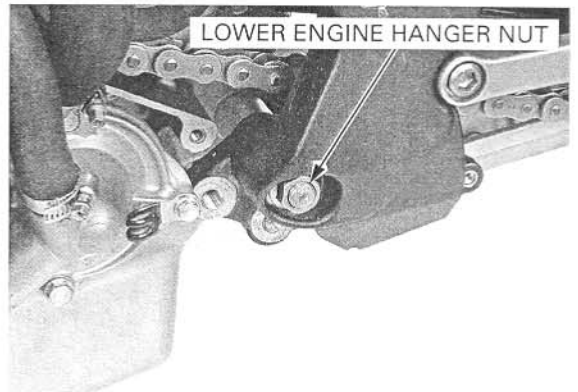

ENGINE REMOVAL/INSTALLATION

Support the engine using a jack or other adjustable support to ease engine hanger bolts removal.

Remove the following:

- Swingarm pivot shaft
- Lower engine hanger bolt and collars
- Rear engine hanger bolt and collars

Carefully lower the adjustable support, then remove the engine from the frame.

- A hoist or equivalent is required to support the swingarm when removing the engine.
- Install the swingarm pivot shaft to allow the chassis to be moved and stored during engine service.

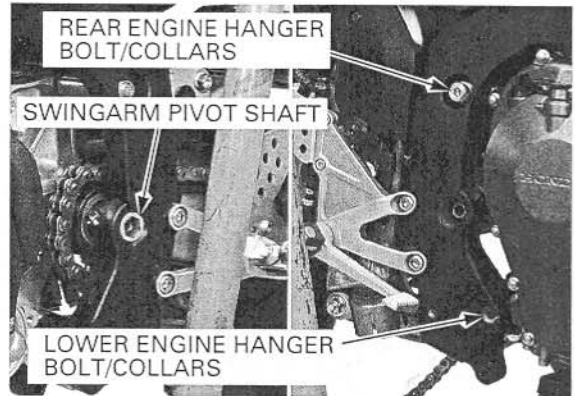

ENGINE INSTALLATION

- Note the direction of the hanger bolts/collars.
- When tighten the lock nut with the lock nut wrench, refer to the torque wrench reading information in "SERVICE INFORMATION" (page 8-3).
- The jack height must be continually adjusted to relieve stress from the mounting fasteners.
- Route the wire and cables properly (page 1-22).
- Be sure to tighten all engine mounting fasteners to the specified torque in the specified sequence described following page. If you mistake the tightening torque or sequence, loosen all mounting fasteners, then tighten them again to the specified torque in the specified sequence.

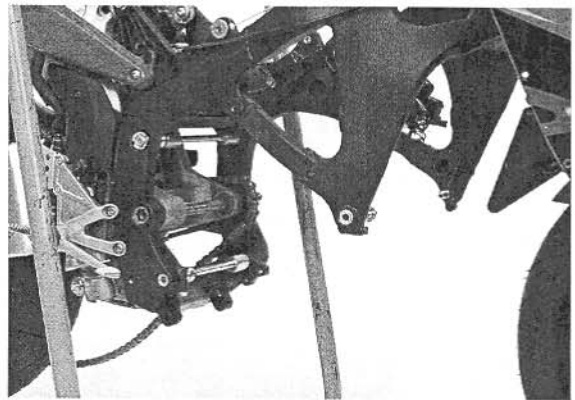

Install the rear engine hanger adjusting bolt fully from the right rear inside of the frame.

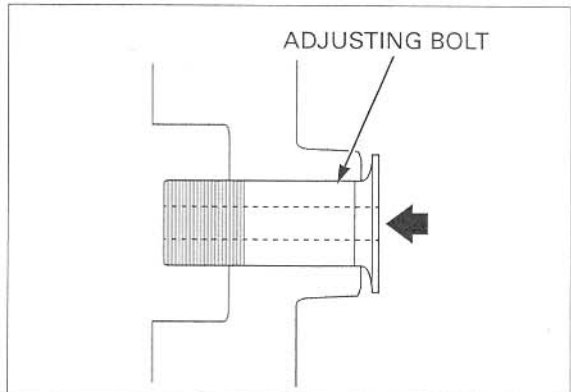

Carefully install the engine into the frame.

- A hoist or equivalent is required to support the swingarm when installing the engine.

Temporarily install the collars, rear and lower engine hanger bolts from the right side.

California type: Temporarily install the collars, rear and lower engine hanger bolts from the right side, then install the joint pipe between the rear engine hanger left side collar and engine.

Temporarily install the swingarm pivot shaft from the left side.

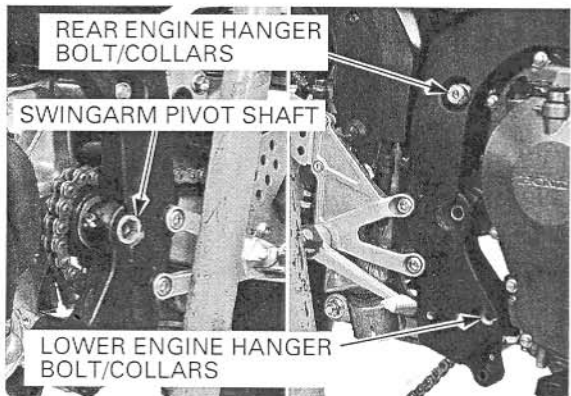

ENGINE REMOVAL/INSTALLATION

Tighten the lower engine hanger nut to the specified torque.

TORQUE: 59 N·m (6.0 kgf·m, 43 lbf·ft)

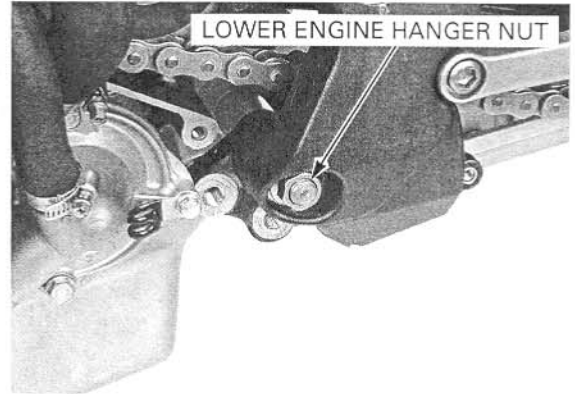

Tighten the rear engine hanger bolt with the adjusting bolt to the specified torque.

TORQUE: 9.8 N·m (1.0 kgf·m, 7 lbf·ft)

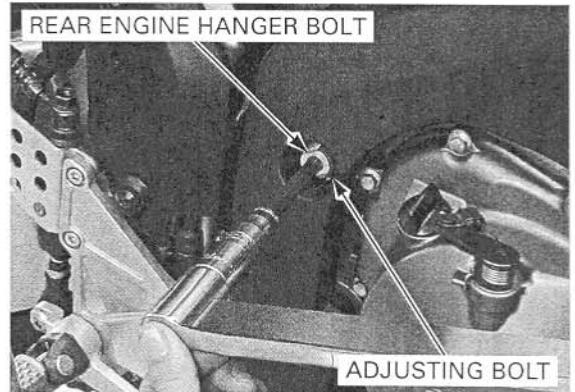

Install and tighten the rear engine hanger lock nut to the specified torque, while holding the rear engine hanger bolt.

TOOL:

Lock nut wrench

07VMA-MBB0100 or
07VMA-MBB0101

TORQUE:

Actual: 54 N·m (5.5 kgf·m, 40 lbf·ft)

Indicated: 49 N·m (5.0 kgf·m, 39 lbf·ft)

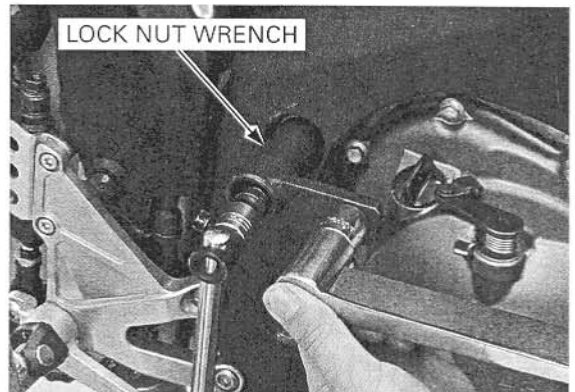

Tighten the rear engine hanger nut to the specified torque while holding the rear engine hanger bolt.

TORQUE: 59 N·m (6.0 kgf·m, 43 lbf·ft)

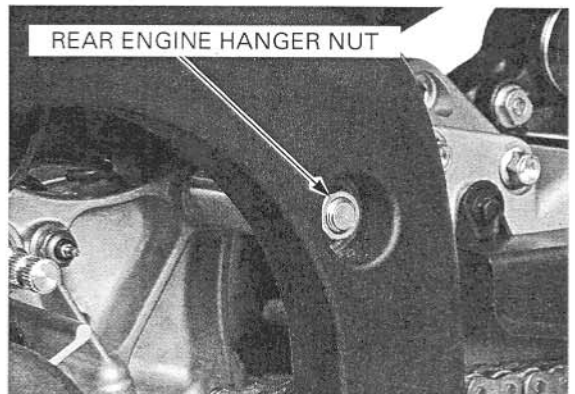

ENGINE REMOVAL/INSTALLATION

Install and tighten the left side front engine hanger bolt to the specified torque.

TORQUE: 54 N·m (5.5 kgf·m, 40 lbf·ft)

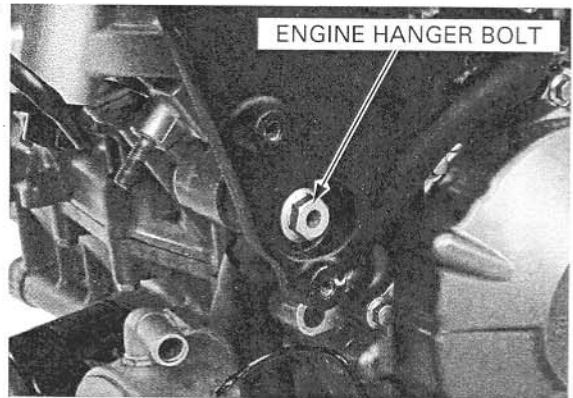

Install the right side front engine hanger bolt, collar and nut. Tighten the nut to the specified torque while holding the bolt.

TORQUE: 54 N·m (5.5 kgf·m, 40 lbf·ft)

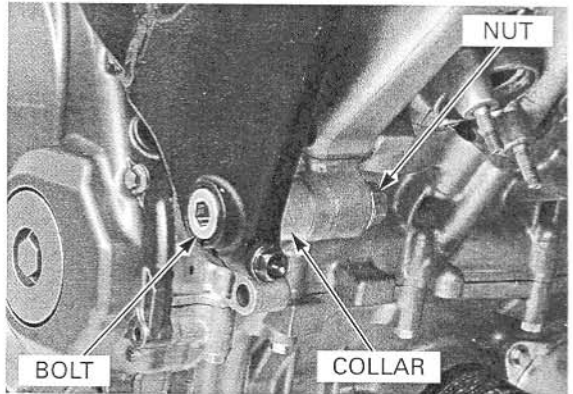

Tighten the lower engine hanger pinch bolt.

TORQUE: 27 N·m (2.7 kgf·m, 20 lbf·ft)

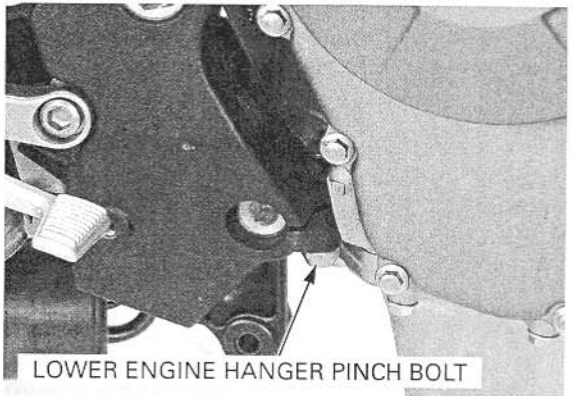

Tighten the front engine hanger pinch bolt to the specified torque.

TORQUE: 27 N·m (2.7 kgf·m, 20 lbf·ft)

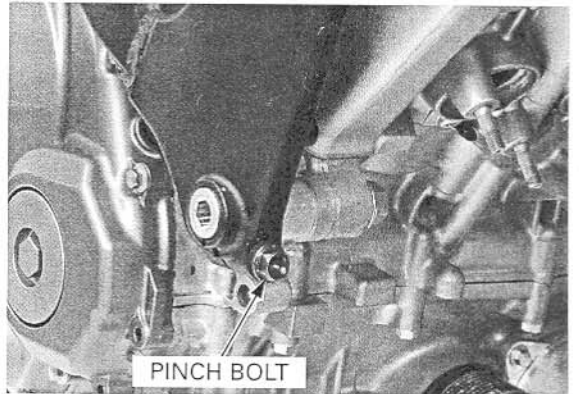

ENGINE REMOVAL/INSTALLATION

Install and tighten the swingarm pivot nut while holding the pivot shaft to the specified torque.

TORQUE: 93 N·m (9.5 kgf·m, 69 lbf·ft)

Tighten the pinch bolts to the specified torque.

TORQUE: 27 N·m (2.7 kgf·m, 20 lbf·ft)

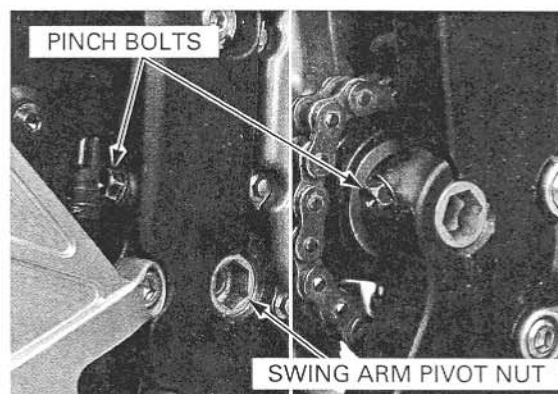

Install the side stand bracket assembly and tighten the socket bolts to the specified torque.

TORQUE: 39 N·m (4.0 kgf·m, 33 lbf·ft)

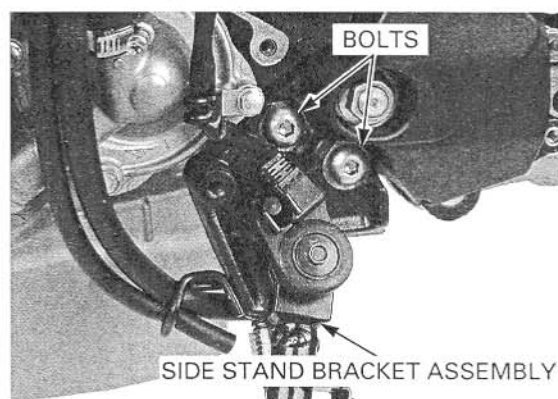

Connect the direct ignition coil 6P (Black) connector.

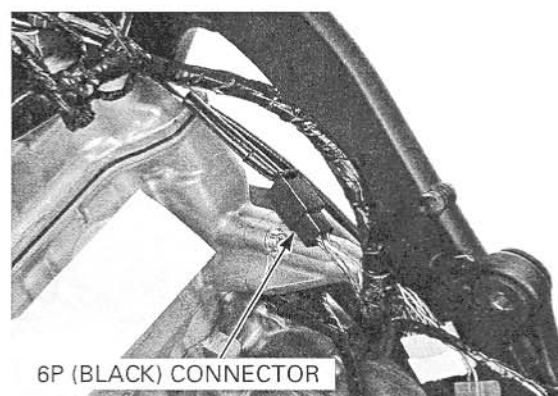

Connect the PAIR control solenoid valve 2P (Black) connector.

Install the heat guard rubber.

Connect the PAIR air hoses into the cylinder head and install the PAIR control solenoid valve.

Install the crankcase breather hose.

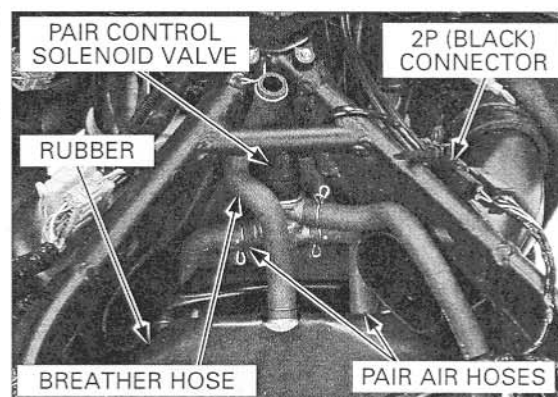

ENGINE REMOVAL/INSTALLATION

Coat a new O-ring with oil and install it into the starter motor groove.

Install the starter motor into the crankcase.

Route the starter motor cable and ground cable. Connect the ground cable, then tighten the mounting bolts.

Connect the starter motor cable, then tighten the terminal nut to the specified torque.

TORQUE: 12 N·m (1.2 kgf·m, 9 lbf·ft)

Install the rubber cap securely.

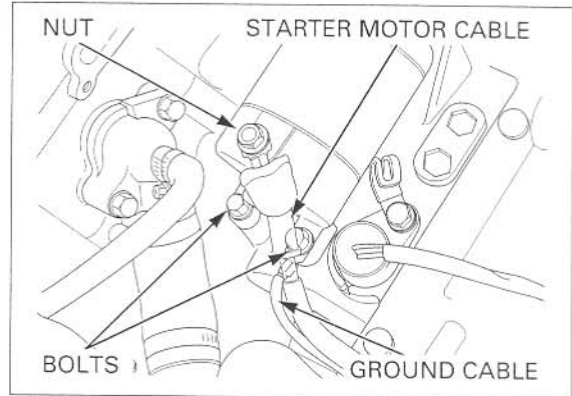

Install the thermostat housing (page 7-9).

Connect the ECT sensor connector and vehicle speed sensor 3P (Natural) connector.

Connect the ignition pulse generator 2P (Red) connector.

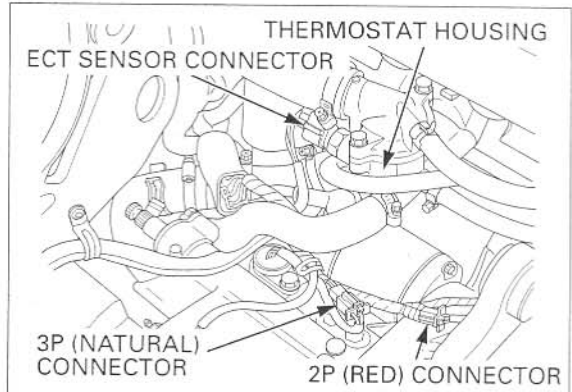

Install the radiator reserve tank (page 7-18).

Connect the oil pressure switch wire and tighten the screw to the specified torque.

TORQUE: 2.0 N·m (0.2 kgf·m, 1.4 lbf·ft)

Install the dust cover over the oil pressure switch.

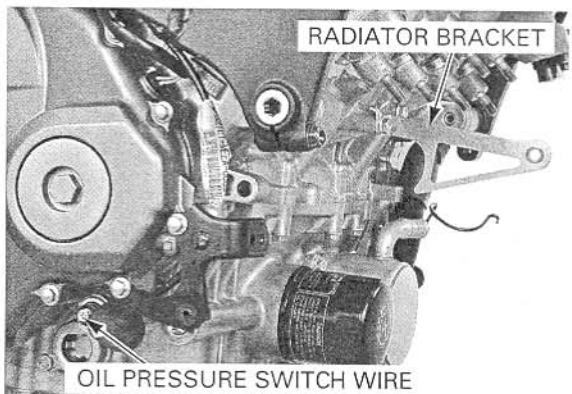

Connect the clutch cable to the clutch lifter lever. Install the clutch cable guide plate to the right crankcase cover and tighten the mounting bolt.

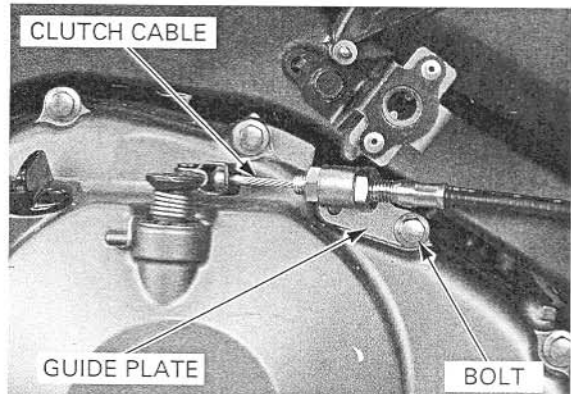

ENGINE REMOVAL/INSTALLATION

Connect the radiator hose into the water pump and water hoses into the oil cooler. Tighten the hose clamp screws.

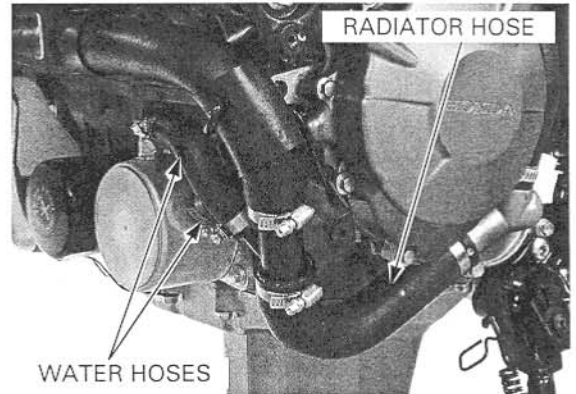

Connect the following:

- Cam pulse generator 2P (Natural) connector
- Side stand switch 2P (Green) connector
- Neutral switch connector

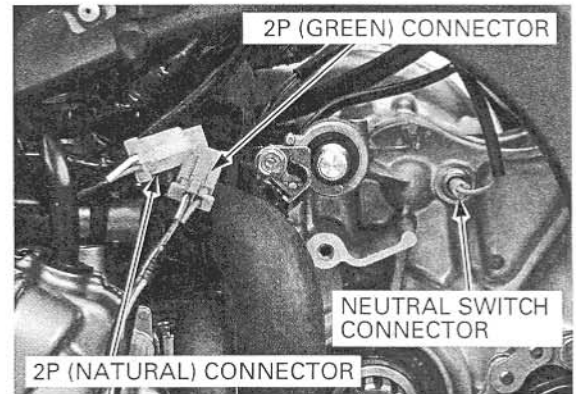

Install the drive sprocket, special bolt and washer.

Tighten the drive sprocket special bolt to the specified torque.

TORQUE: 54 N·m (5.5 kgf·m, 40 lbf·ft)

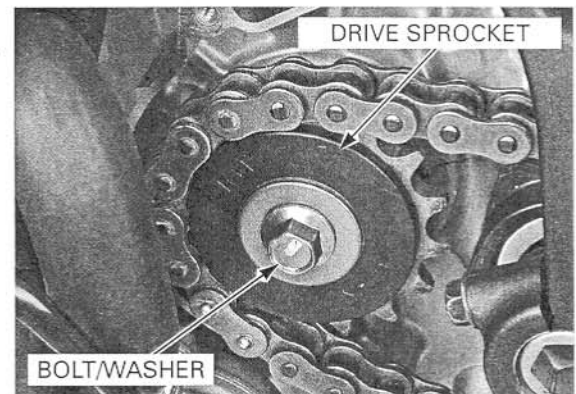

Install the guide plate, drive sprocket cover and tighten the bolts securely.

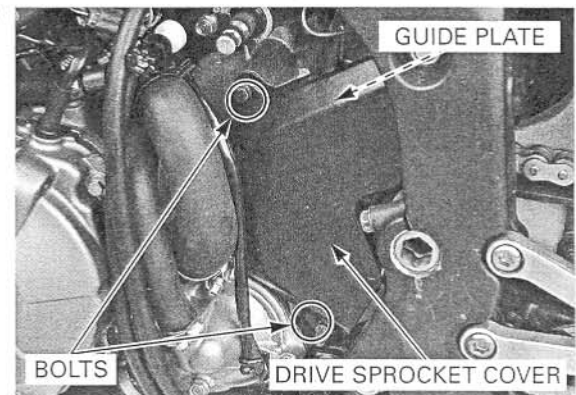

ENGINE REMOVAL/INSTALLATION

Install the gearshift arm to the gearshift spindle, aligning the arm slit with the punch mark on the spindle.

Install and tighten the pinch bolt.

Install the bolt, wave washer, washer and gear shift pedal.

Tighten the gearshift pedal pivot bolt securely.

Install the following:

- Regulator/rectifier (page 17-11)
- Throttle body (page 6-77)
- Air cleaner housing (page 6-66)
- Radiator (page 7-13)
- Fuel tank (page 6-62)
- Exhaust pipe (page 3-26)
- Middle cowls (page 3-8)
- Lower cowls (page 3-6)

Adjust the drive chain slack (page 4-21).

Pour recommended engine oil up to the proper level (page 4-16).

Fill the cooling system with the recommended coolant and bleed any air (page 7-6).

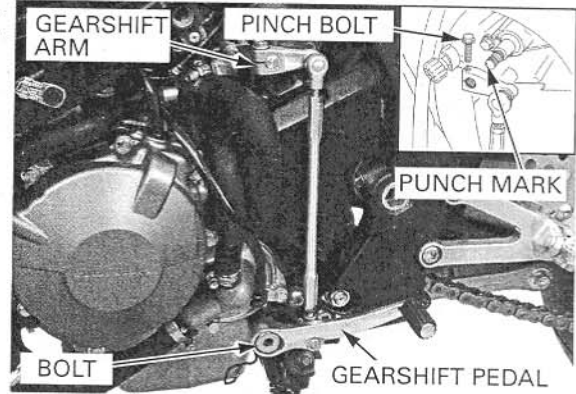

9. CYLINDER HEAD/VALVES

COMPONENT LOCATION	9-2	CYLINDER HEAD INSPECTION	9-16
SERVICE INFORMATION	9-3	VALVE GUIDE REPLACEMENT	9-19
TROUBLESHOOTING	9-5	VALVE SEAT INSPECTION/REFACING	9-19
CYLINDER COMPRESSION TEST	9-6	CYLINDER HEAD ASSEMBLY	9-22
CYLINDER HEAD COVER REMOVAL	9-6	CYLINDER HEAD INSTALLATION	9-24
CYLINDER HEAD COVER DISASSEMBLY	9-7	CAMSHAFT INSTALLATION	9-26
CAMSHAFT REMOVAL	9-8	CYLINDER HEAD COVER ASSEMBLY	9-31
CYLINDER HEAD REMOVAL	9-13	CYLINDER HEAD COVER INSTALLATION	9-32
CYLINDER HEAD DISASSEMBLY	9-15	CAM CHAIN TENSIONER LIFTER	9-34

CYLINDER HEAD/VALVES

COMPONENT LOCATION

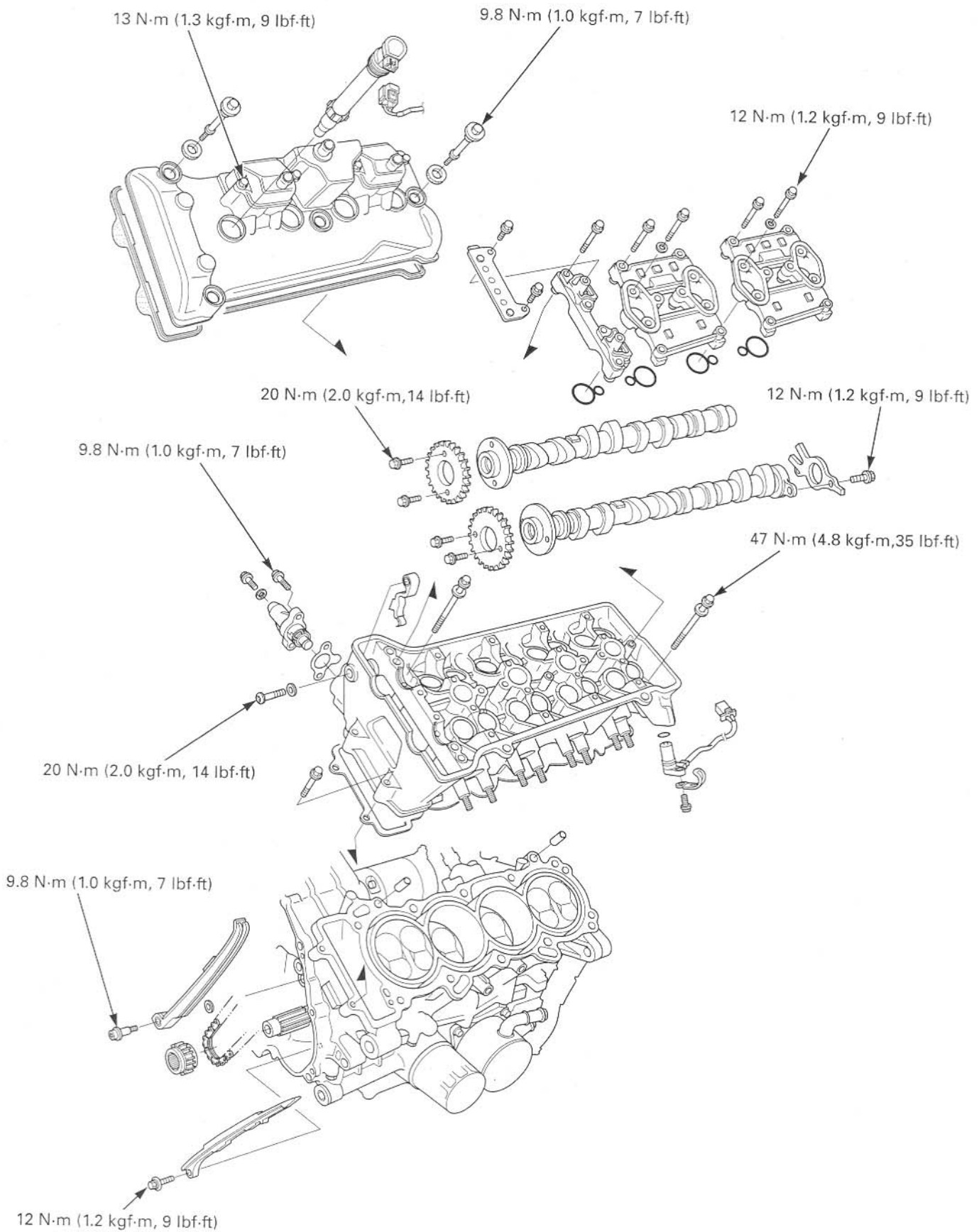

SERVICE INFORMATION

GENERAL

- This section covers service of the cylinder head, valves and camshaft.
- The camshaft services can be done with the engine installed in the frame. The cylinder head service requires engine removal.
- When disassembling, mark and store the disassembled parts to ensure that they are reinstalled in their original locations.
- Clean all disassembled parts with cleaning solvent and dry them by blowing them off with compressed air before inspection.
- Camshaft lubricating oil is fed through oil passages in the cylinder head. Clean the oil passages before assembling cylinder head.
- Be careful not to damage the mating surfaces when removing the cylinder head cover and cylinder head.

SPECIFICATIONS

Unit: mm (in)









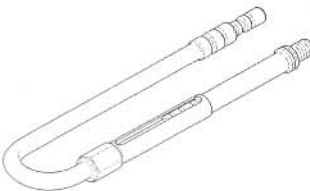
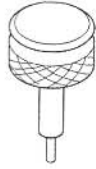
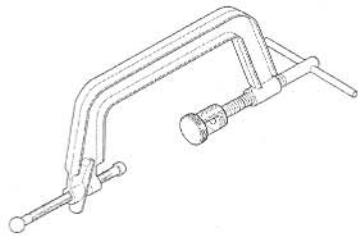

ITEM		STANDARD		SERVICE LIMIT
Cylinder compression		1,226 kPa (12.5 kgf/cm ² , 178psi) at 350 rpm		
Valve clearance		IN	0.20 ± 0.03 (0.008 ± 0.001)	–
		EX	0.28 ± 0.03 (0.011 ± 0.001)	–
Camshaft	Cam lobe height	IN	36.36 – 36.60 (1.431 – 1.441)	36.34 (1.431)
		EX	35.34 – 35.58 (1.391 – 1.401)	35.32 (1.391)
	Runout		–	0.05 (0.002)
	Oil clearance		0.020 – 0.062 (0.0008 – 0.0024)	0.10 (0.004)
Valve lifter	Valve lifter O.D.	25.978 – 25.993 (1.0228 – 1.0233)		25.97 (1.022)
	Valve lifter bore I.D.	26.010 – 26.026 (1.0240 – 1.0246)		26.04 (1.025)
Valve, valve guide	Valve stem O.D.	IN	3.975 – 3.990 (0.1565 – 0.1571)	3.965 (0.1561)
		EX	3.965 – 3.980 (0.1561 – 0.1567)	3.955 (0.1557)
	Valve guide I.D.	IN/EX	4.000 – 4.012 (0.1575 – 0.1580)	4.04 (0.159)
	Stem-to-guide clearance	IN	0.010 – 0.037 (0.0004 – 0.0015)	0.075 (0.0030)
		EX	0.020 – 0.047 (0.0008 – 0.0019)	0.085 (0.0033)
	Valve guide projection above cylinder head	IN	17.1 – 17.4 (0.67 – 0.69)	–
		EX	13.3 – 13.6 (0.52 – 0.54)	–
	Valve seat width	IN	0.90 – 1.10 (0.035 – 0.043)	1.5 (0.06)
EX		0.90 – 1.10 (0.035 – 0.043)	1.5 (0.06)	
Valve spring free length	IN	Inner	36.17 (1.424)	35.1 (1.38)
		Outer	39.76 (1.565)	38.8 (1.53)
	EX	Inner	35.34 (1.391)	34.4 (1.35)
		Outer	39.05 (1.537)	38.1 (1.50)
Cylinder head warpage		–		0.10 (0.004)

TORQUE VALUES

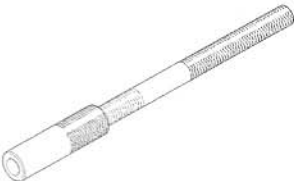
Cylinder head mounting bolt	47 N·m (4.8 kgf·m, 35 lbf·ft)	Apply molybdenum disulfide oil to the threads and seating surface
Camshaft holder bolt	12 N·m (1.2 kgf·m, 9 lbf·ft)	Apply oil to the threads
Cylinder head cover bolt	9.8 N·m (1.0 kgf·m, 7 lbf·ft)	
Breather plate bolt	13 N·m (1.3 kgf·m, 9 lbf·ft)	Apply a locking agent to the threads
PAIR reed valve cover bolt	13 N·m (1.3 kgf·m, 9 lbf·ft)	CT bolt
Cam sprocket bolt	20 N·m (2.0 kgf·m, 14 lbf·ft)	CT bolt
Cam pulse generator rotor bolt	12 N·m (1.2 kgf·m, 9 lbf·ft)	Apply a locking agent to the threads
Cam chain tensioner lifter mounting socket bolt	9.8 N·m (1.0 kgf·m, 7 lbf·ft)	Apply a locking agent to the threads
Cam chain tensioner A pivot bolt	9.8 N·m (1.0 kgf·m, 7 lbf·ft)	Apply a locking agent to the threads
Cam chain tensioner B pivot bolt	20 N·m (2.0 kgf·m, 14 lbf·ft)	Apply a locking agent to the threads
Cam chain guide A bolt	12 N·m (1.2 kgf·m, 9 lbf·ft)	
Spark plug	16 N·m (1.6 kgf·m, 12 lbf·ft)	

CYLINDER HEAD/VALVES

TOOLS

<p>Compression gauge attachment 07RMJ-MY50100</p>  <p>or equivalent commercially available in U.S.A.</p>	<p>Cam chain tensioner holder 07ZMG-MCAA400</p> 	<p>Valve spring compressor 07757-0010000</p> 
<p>Valve spring compressor attachment 07959-KM30101</p> 	<p>Tappet hole protector 07HMG-MR70002</p>  <p>not available in U.S.A.</p>	<p>Valve guide driver 07JMD-KY20100</p> 
<p>Valve guide driver 07743-0020000</p>  <p>not available in U.S.A.</p>	<p>Valve guide reamer, 4.008 mm 07MMH-MV90100</p>  <p>or 07MMH-MV9010A (U.S.A. only)</p>	<p>Valve seat cutter, 27.5 mm (45° IN) 07780-0010200</p>  <p>or equivalent commercially available in U.S.A.</p>
<p>Valve seat cutter, 24 mm (45° EX) 07780-0010600</p>  <p>or equivalent commercially available in U.S.A.</p>	<p>Flat cutter, 30 mm (32° IN) 07780-0012200</p>  <p>or equivalent commercially available in U.S.A.</p>	<p>Flat cutter, 24 mm (32° EX) 07780-0012500</p>  <p>or equivalent commercially available in U.S.A.</p>

CYLINDER HEAD/VALVES

<p>Interior cutter, 26 mm (60° IN) 07780-0014500</p>  <p>or equivalent commercially available in U.S.A.</p>	<p>Interior cutter, 22 mm (60° EX) 07780-0014202</p>  <p>or equivalent commercially available in U.S.A.</p>	<p>Cutter holder, 4.0 mm 07781-0010500</p>  <p>or equivalent commercially available in U.S.A.</p>
--	--	--

TROUBLESHOOTING

- Engine top-end problems usually affect engine performance. These problem can be diagnosed by a compression test or by tracing engine noises to the top-end with a sounding rod stethoscope.
- If the performance is poor at low speeds, check for white smoke in the crankcase breather hose. If the hose is smoky, check for a seized piston ring (page 13-15).

Compression too low, hard starting or poor performance at low speed

- Valves:
 - Incorrect valve adjustment
 - Burned or bent valve
 - Incorrect valve timing
 - Broken valve spring
 - Uneven valve seating
- Cylinder head:
 - Leaking or damaged head gasket
 - Warped or cracked cylinder head
- Worn cylinder, piston or piston rings (page 13-15)

Compression too high, overheating or knocking

- Excessive carbon build-up on piston crown or on combustion chamber

Excessive smoke

- Cylinder head:
 - Worn valve stem or valve guide
 - Damaged stem seal
- Worn cylinder, piston or piston rings (page 13-15)

Excessive noise

- Cylinder head:
 - Incorrect valve adjustment
 - Sticking valve or broken valve spring
 - Damaged or worn camshaft
 - Loose or worn cam chain
 - Worn or damaged cam chain
 - Worn or damaged cam chain tensioner
 - Worn cam sprocket teeth
- Worn cylinder, piston or piston rings (page 13-15)

Rough idle

- Low cylinder compression

CYLINDER HEAD/VALVES

CYLINDER COMPRESSION TEST

Warm the engine to normal operating temperature. Stop the engine and remove the all direct ignition coil/spark plug caps and spark plugs (page 4-7). Lift and support the fuel tank (page 6-61).

Disconnect the fuel pump unit 3P (Black) connector.

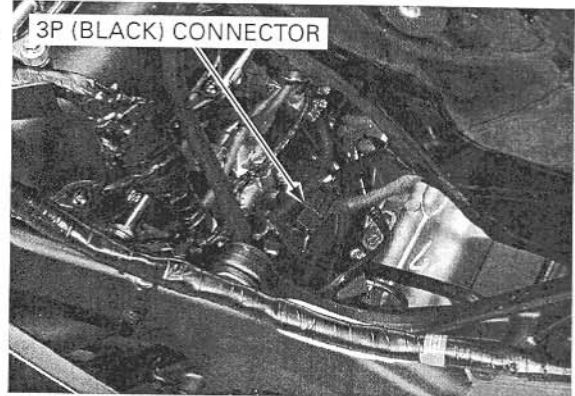

Install a compression gauge into the spark plug hole.

TOOL:

Compression gauge attachment

07RMJ-MY50100 or equivalent commercially available in U.S.A.

Open the throttle all the way and crank the engine with the starter motor until the gauge reading stops rising.

The maximum reading is usually reached within 4 – 7 seconds.

Compression pressure:

1,226 kPa (12.5 kgf/cm², 178 psi) at 350 rpm

Low compression can be caused by:

- Blown cylinder head gasket
- Improper valve adjustment
- Valve leakage
- Worn piston ring or cylinder

High compression can be caused by:

- Carbon deposits in combustion chamber or on piston head

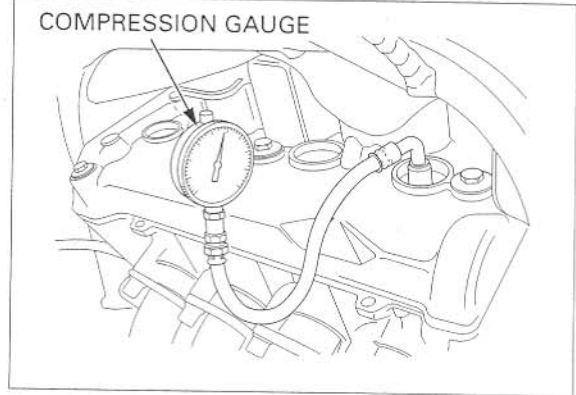

CYLINDER HEAD COVER REMOVAL

Remove the throttle body (page 6-72).

Remove the crankcase breather hose.

Disconnect the PAIR control solenoid valve 2P (Black) connector.

Disconnect the PAIR air hoses from the cylinder head and remove the PAIR control solenoid valve.

Remove the heat guard rubber.

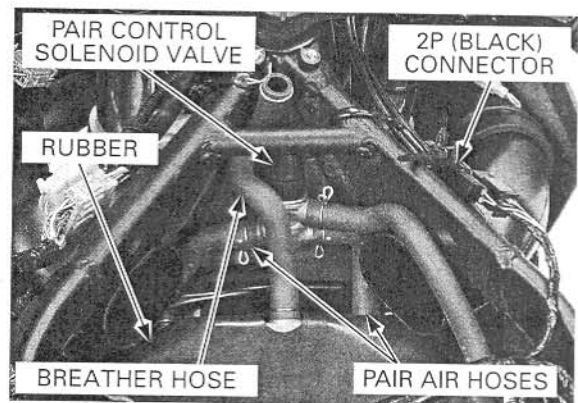

CYLINDER HEAD/VALVES

Disconnect the ignition coil connectors and remove the direct ignition coils.

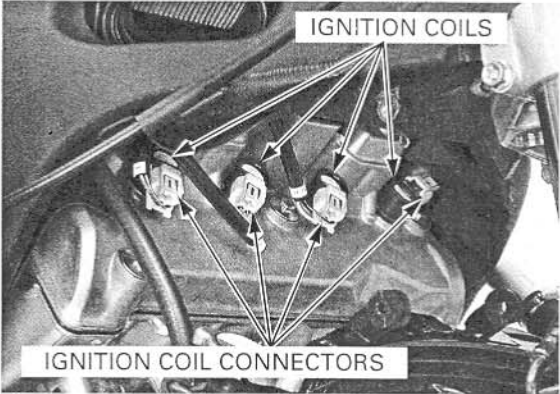

Remove the cylinder head cover bolts.

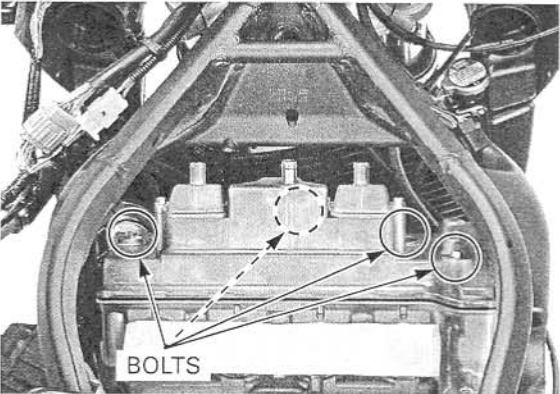

Remove the cylinder head cover from the cylinder head.

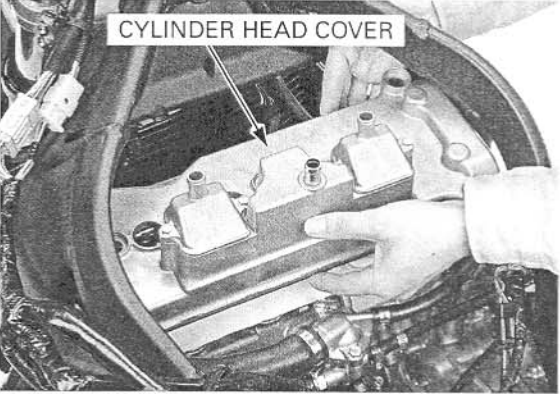

CYLINDER HEAD COVER DISASSEMBLY

Remove the cylinder head cover packing.
Remove the bolts and breather plate and gasket.

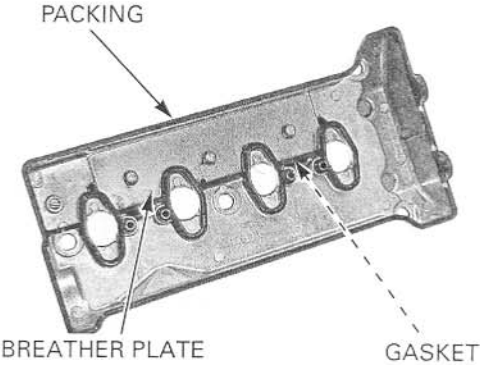

CYLINDER HEAD/VALVES

Remove the bolts and PAIR check valve cover.

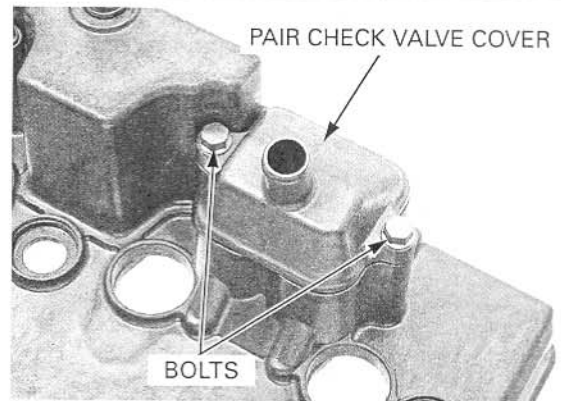

Remove the PAIR check valves from the cylinder head cover.

Check the PAIR check valve for wear or damage, replace if necessary.

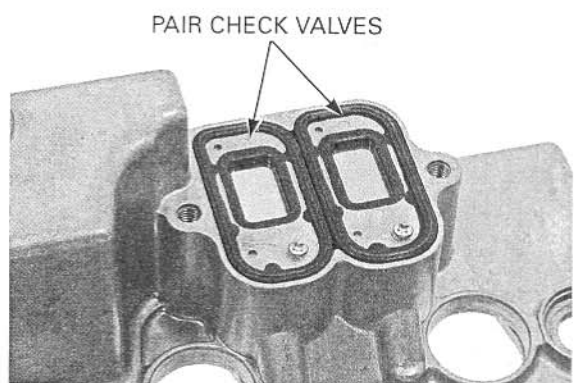

Remove the port plates from the cylinder head cover.

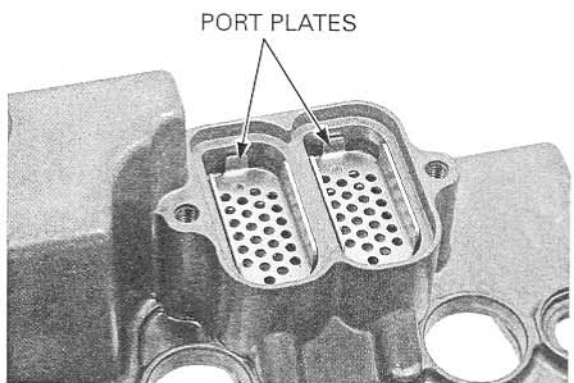

CAMSHAFT REMOVAL

Remove the cylinder head cover (page 9-6).

Avoid damaging the cam pulse generator while removing the camshafts, remove the bolt, clamp and cam pulse generator from the cylinder head.

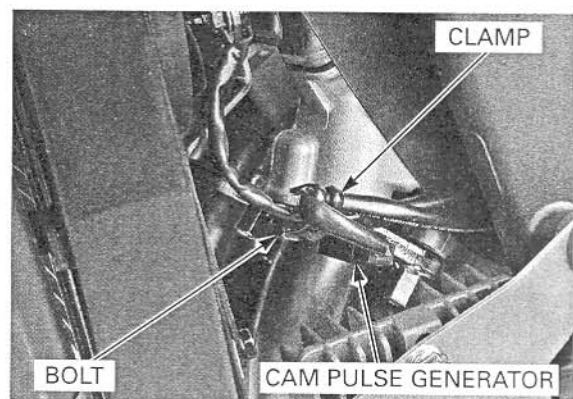

CYLINDER HEAD/VALVES

Remove the timing hole cap and O-ring.

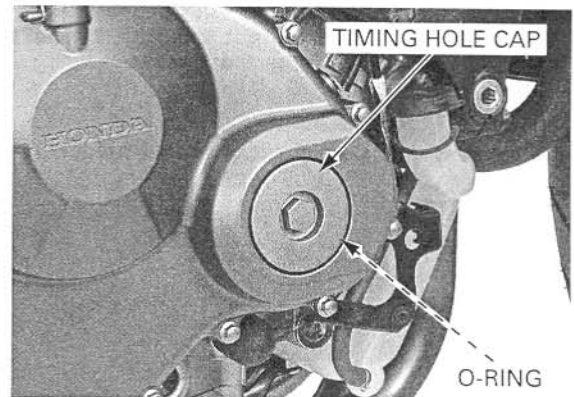

Turn the crankshaft clockwise, align the "T" mark on the ignition pulse generator rotor with the index mark on the right crankcase cover.

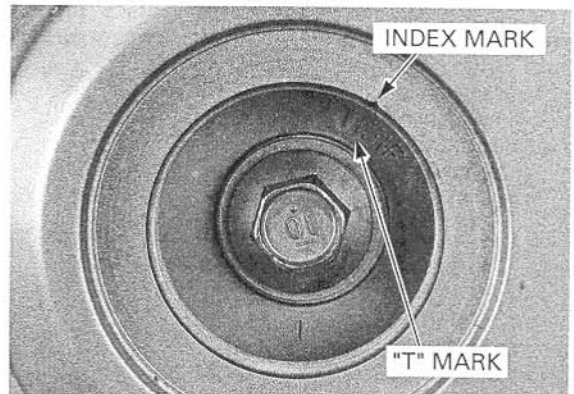

The timing marks ("IN" and "EX") on the cam sprockets must be flush with the cylinder head surface and facing outward as shown.

If the timing marks on the cam sprocket are facing inward, turn the crankshaft clockwise one full turn (360°) and realign the timing marks with the cylinder head surface so they are facing outward.

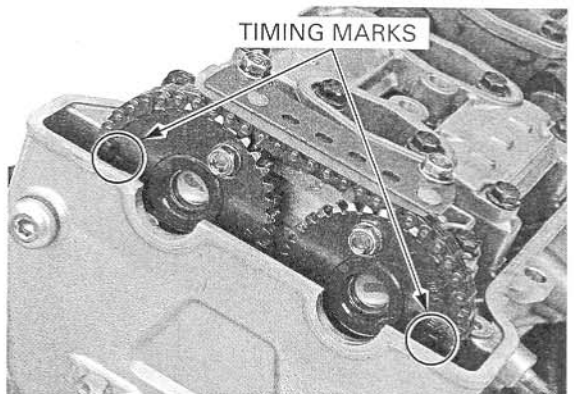

Remove the cam chain tensioner lifter sealing bolt and sealing washer.

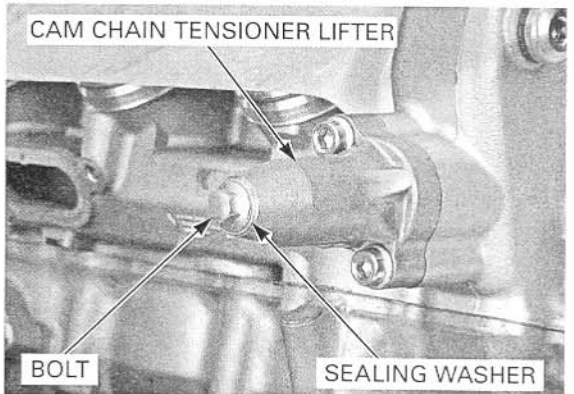

CYLINDER HEAD/VALVES

Turn the tensioner lifter shaft fully in (clockwise) and secure it using the special tool to prevent damaging the cam chain.

TOOL:

Cam chain tensioner holder 07ZMG-MCAA400

It is not necessary to remove the cam sprocket from the camshaft except when replacing the camshaft and/or cam sprocket.

Be careful not to drop the cam sprocket bolts and cam sprocket into the crankcase.

If you plan to replace the camshaft and/or cam sprocket, loosen the cam sprocket bolts as follows:

- Remove the cam sprocket bolts from the intake and exhaust camshafts.
- Turn the crankshaft clockwise one full turn (360°), remove the other cam sprocket bolts from the camshafts.
- Remove the bolts and cam chain guide B.
- Remove the cam sprockets from the camshafts.
- Remove the bolts and cam pulse generator rotor from the exhaust camshaft.

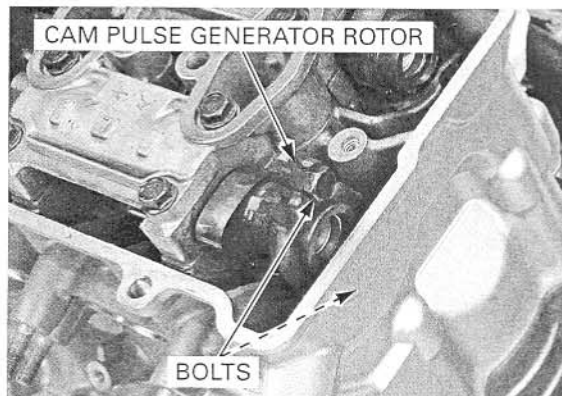
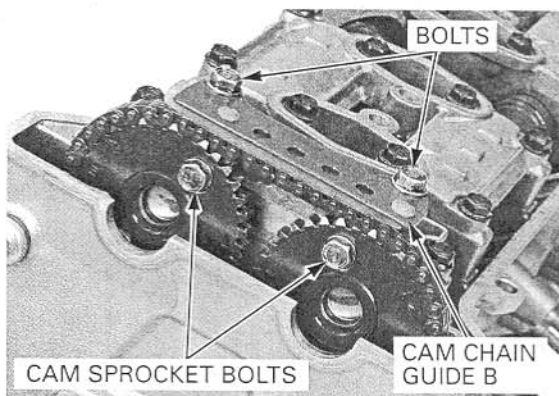
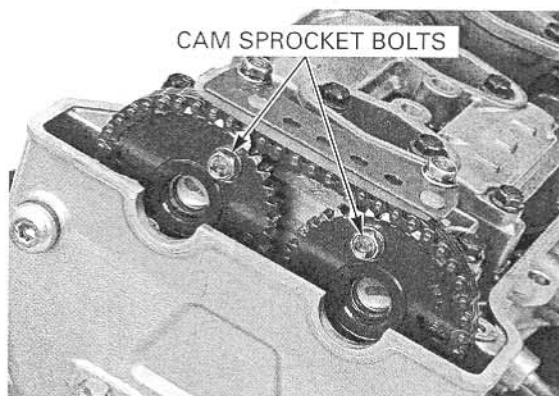
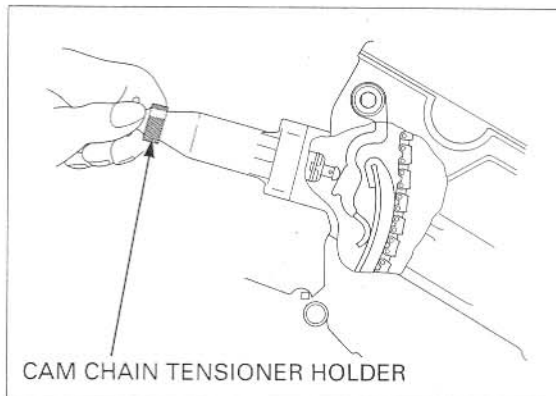

Remove the bolts and cam chain guide B.

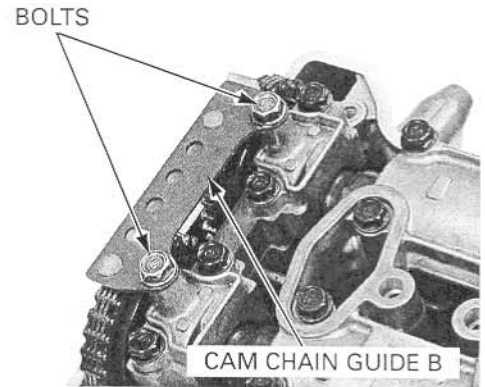

Suspend the cam chain with a piece of wire to prevent the chain from falling into the crankcase.

Loosen and remove the camshaft holder bolts/washers, then remove the camshaft holders and camshafts.

NOTE:

From outside to inside, loosen the bolts in a criss-cross pattern in several steps or the camshaft holder might break.

Do not forcibly remove the dowel pins from the camshaft holders.

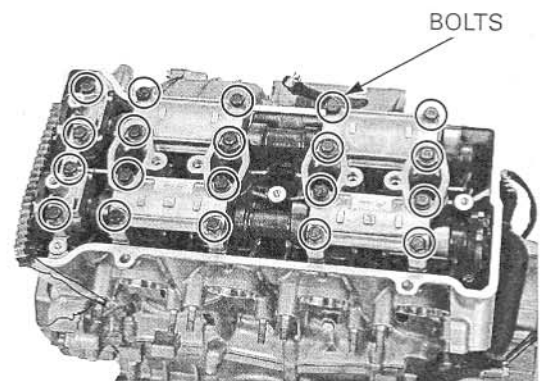

Remove the valve lifters and shims.

- Be careful not to damage the valve lifter bore.
- Shim may stick to the inside of the valve lifter. Do not allow the shims to fall into the crankcase.
- Mark all valve lifters and shims to ensure correct reassembly in their original locations.
- The valve lifter can be easily removed with a valve lapping tool or magnet.
- The shims can be easily removed with a tweezers or magnet.

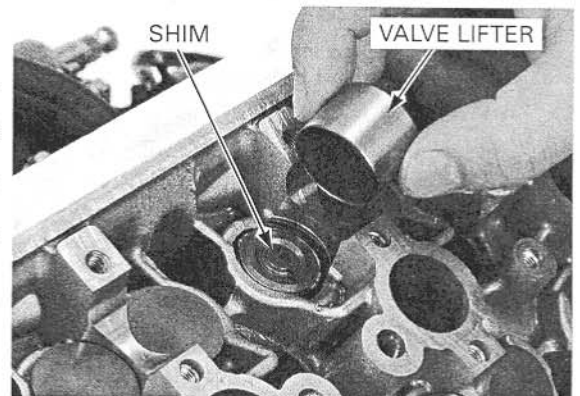

INSPECTION

CAMSHAFT

Check the cam and journal surfaces of the camshaft for scoring, scratches or evidence of insufficient lubrication.

Check the oil holes in the camshaft for clogging.

Support both sides of the camshaft (at journals) with V-blocks and check the camshaft runout with a dial gauge.

SERVICE LIMIT: 0.05 mm (0.002 in)



CYLINDER HEAD/VALVES

Using a micrometer, measure each cam lobe height.

SERVICE LIMITS:

IN: 36.34 mm (1.431 in)

EX: 35.32 mm (1.391 in)

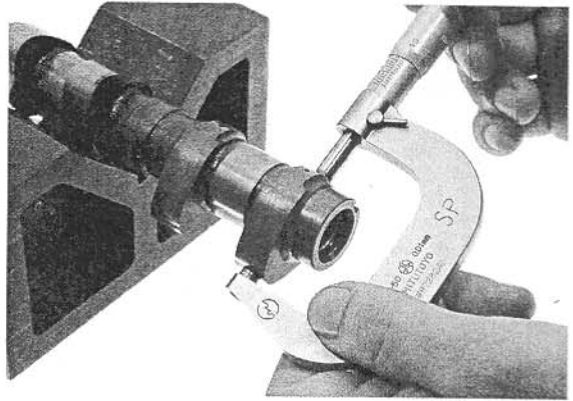

CAMSHAFT HOLDERS

Inspect the bearing surface of the each camshaft holder for scoring, scratches, or evidence of insufficient lubrication.

Inspect the oil orifices of the holders for clogging.

CAMSHAFT HOLDER A

CAMSHAFT HOLDER B

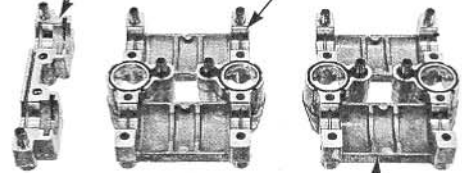

CAMSHAFT HOLDER C

CAM CHAIN GUIDE B

Inspect the cam chain slipper surface of the cam chain guide B for wear or damage.

CAM CHAIN GUIDE B

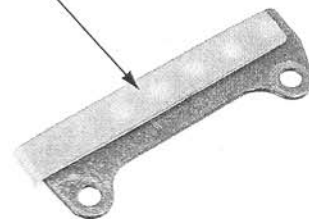

CAMSHAFT OIL CLEARANCE

Do not rotate the camshaft when using plastigauge.

Wipe any oil from the journals of the camshaft, cylinder head and camshaft holders. Lay a strip of plastigauge lengthwise on top of each camshaft journal.

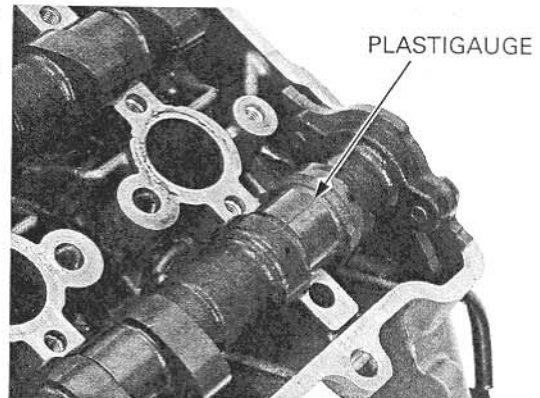

CYLINDER HEAD/VALVES

Be sure the dowel pins in the camshaft holder align the holes in the cylinder head.

Install the each camshaft holder to the correct locations with the identification marks.

- No mark: right camshaft holder
- "R" mark: center camshaft holder
- "L" mark: left camshaft holder

Apply engine oil to the threads and seating surfaces of the camshaft holder bolts.

Install the twenty holder bolts with the eight sealing washers.

Finger tighten the bolts.

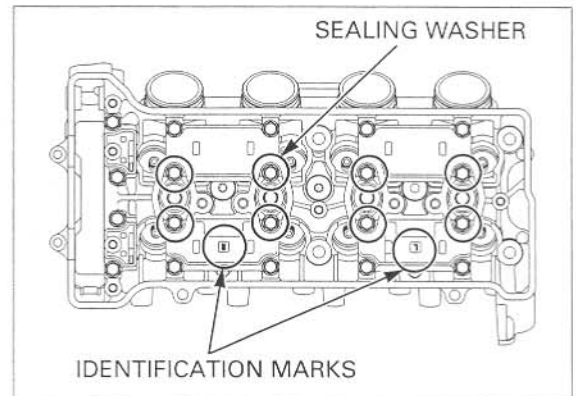

First gradually tighten the four bolts (No.5 – No.6 – No.7 – No.8) in the numerical order cast on the camshaft holders.

Gradually tighten the other camshaft holder bolts until the camshaft holders lightly contact the cylinder head surface.

NOTICE

Failure to tighten the camshaft holder in a criss-cross pattern might cause a camshaft holder to break.

Tighten all camshaft holder bolts in the numerical order casted on the camshaft holders.

TORQUE: 12 N·m (1.2 kgf·m, 9 lbf·ft)

Remove the camshaft holders and measure the width of each plastigauge. The widest thickness determines the oil clearance.

SERVICE LIMIT: 0.10 mm (0.004 in)

When the service limits are exceeded, replace the camshaft and recheck the oil clearance. Replace the cylinder head and camshaft holders as a set if the clearance still exceeds the service limit.

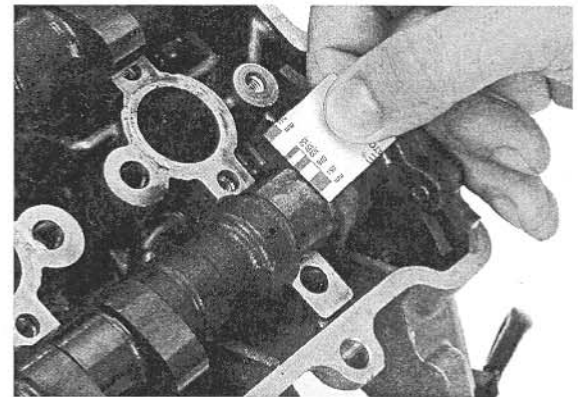
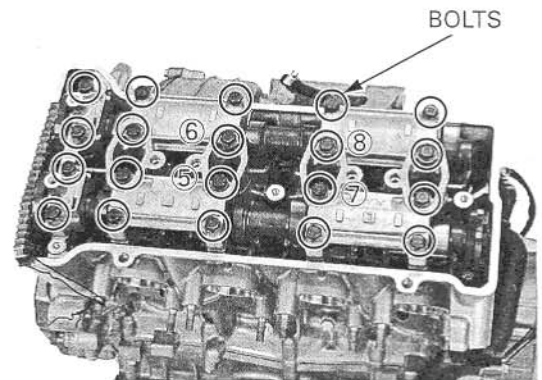

CYLINDER HEAD REMOVAL

Remove the engine from the frame (page 8-5).
Remove the camshafts (page 9-8).

Remove the cylinder drain bolt and sealing washer. Drain the coolant from the cylinder head and cylinder block.

Check the sealing washer is in good condition, replace it if necessary.

Install a new sealing washer and drain bolt. Tighten the drain bolt securely.

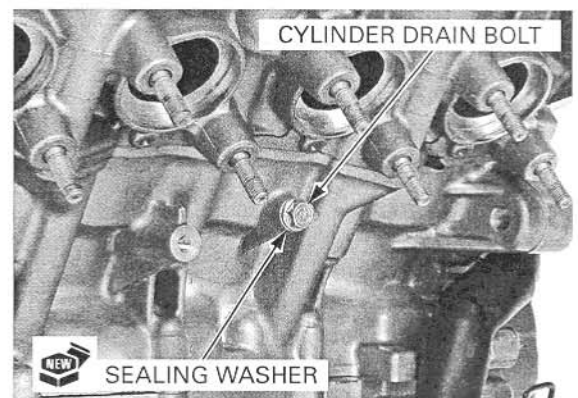

CYLINDER HEAD/VALVES

Remove the socket bolts, cam chain tensioner lifter and gasket.

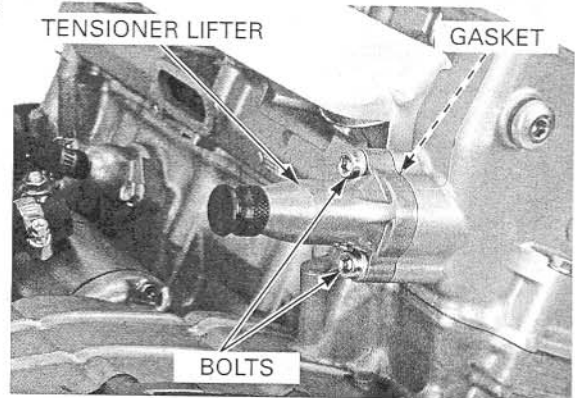

Remove the two 6 mm bolts.

Remove the ten 9 mm bolts/washers.

Remove the cylinder head.

Loosen the 9 mm bolts in a criss-cross pattern in two or three steps.

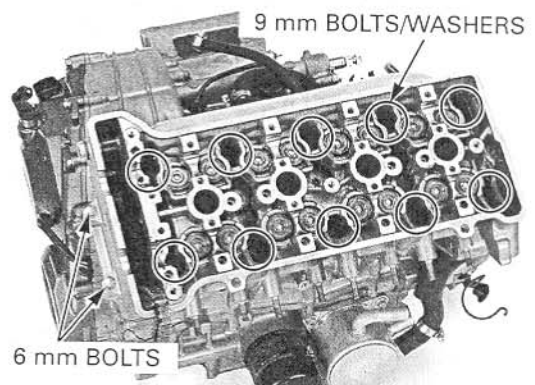

Remove the gasket and dowel pins.

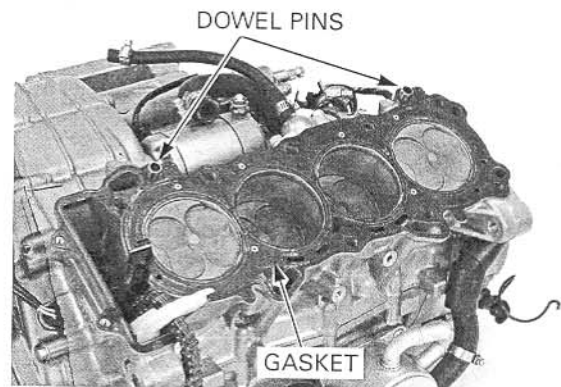

Remove the following:

- Right crankcase cover (page 10-5)
- Starter clutch (page 10-17)

Remove the bolt, washer and cam chain guide A. Remove the socket bolt, cam chain tensioner A and washer.

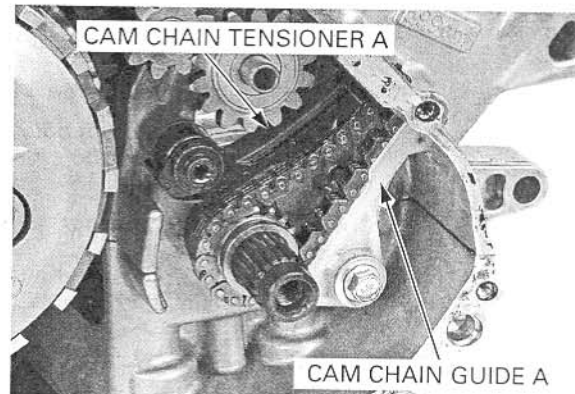

CYLINDER HEAD/VALVES

Remove the cam chain and timing sprocket from the crankshaft.

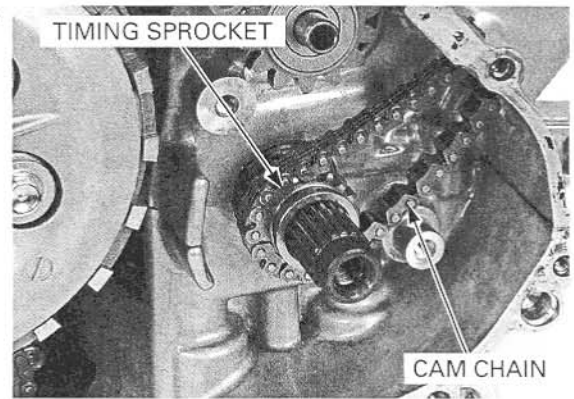

CYLINDER HEAD DISASSEMBLY

Remove the cylinder head (page 9-13).

Remove the bolt, sealing washer and cam chain tensioner B from the cylinder head.

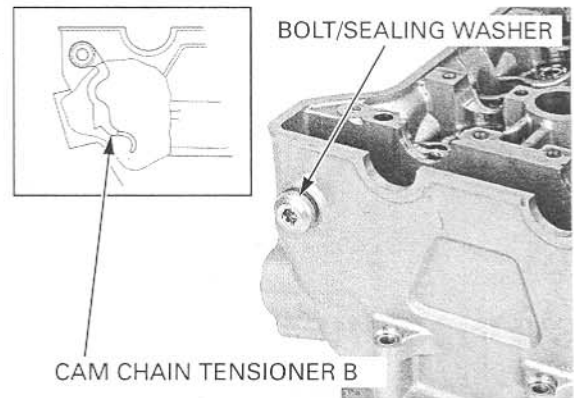

Remove the spark plugs from the cylinder head.

Install the tappet hole protector into the valve lifter bore.

TOOL:

Tappet hole protector

07HMG-MR70002

Not available in U.S.A.

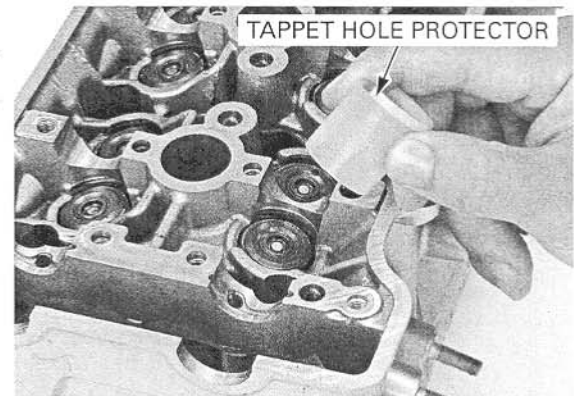

An equivalent tool can easily be made from a plastic 35 mm film container as shown.

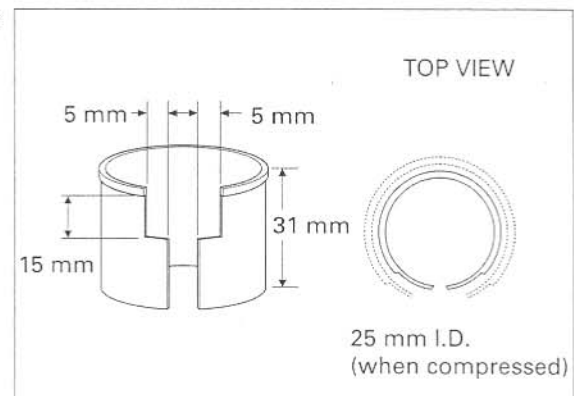

CYLINDER HEAD/VALVES

To prevent loss of tension, do not compress the valve springs more than necessary to remove the cotters.

Remove the valve spring cotters using the special tools as shown.

TOOLS:

Valve spring compressor 07757-0010000

Valve spring compressor attachment 07959-KM30101

VALVE SPRING COMPRESSOR

ATTACHMENT

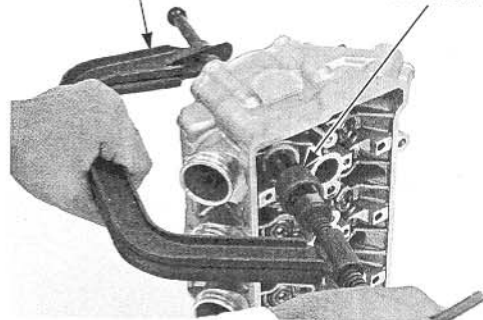

Mark all parts during disassembly so they can be placed back in their original locations.

Remove the following:

- Spring retainer
- Inner/outer valve springs
- Valve
- Stem seal
- Valve spring seat

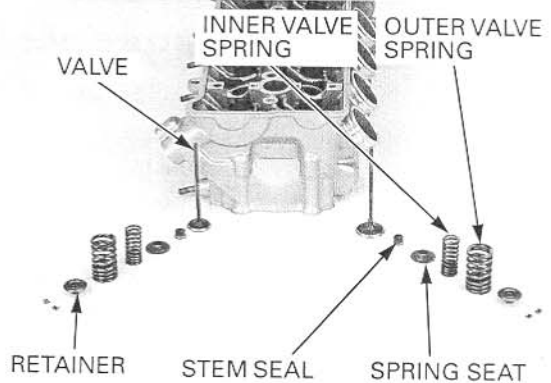

CYLINDER HEAD INSPECTION

CYLINDER HEAD

Avoid damaging the gasket surface.

Remove carbon deposits from the combustion chambers. Check the spark plug hole and valve areas for cracks.

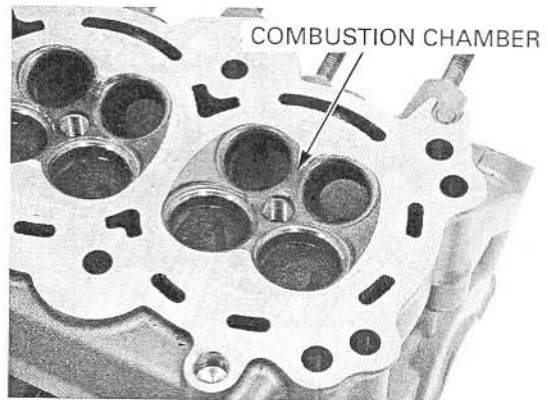

Check the cylinder head for warpage with a straight edge and feeler gauge.

SERVICE LIMIT: 0.10 mm (0.004 in)

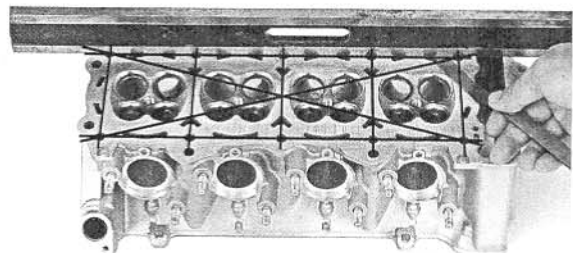

VALVE LIFTER BORE

Inspect each valve lifter bore for scratches or abnormal wear.

Measure the each valve lifter bore I.D.

SERVICE LIMIT: 26.04 mm (1.025 in)

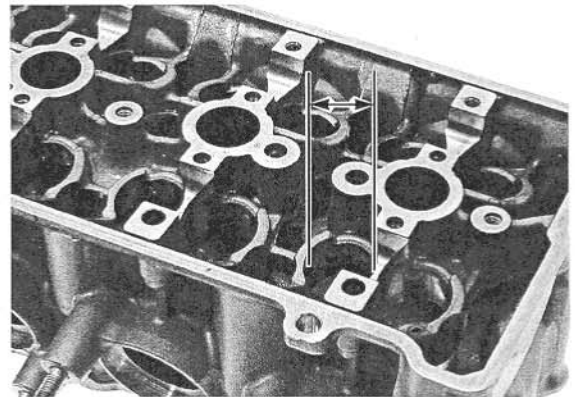

VALVE LIFTER

Inspect each valve lifter for scratches or abnormal wear.

Measure the each valve lifter O.D.

SERVICE LIMIT: 25.97 mm (1.022 in)



VALVE SPRING

Measure the free length of the inner and outer valve springs.

SERVICE LIMITS:

- IN:** Inner: 35.1 mm (1.38 in)
- Outer: 38.8 mm (1.53 in)
- EX:** Inner: 34.4 mm (1.35 in)
- Outer: 38.1 mm (1.50 in)

Replace the springs if they are shorter than the service limits.

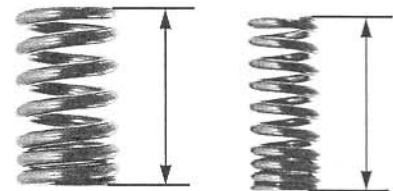

CAM CHAIN TENSIONER/CAM CHAIN GUIDE

Inspect the cam chain tensioner A and cam chain guide A for excessive wear or damage, replace them if necessary.

CAM CHAIN TENSIONER A

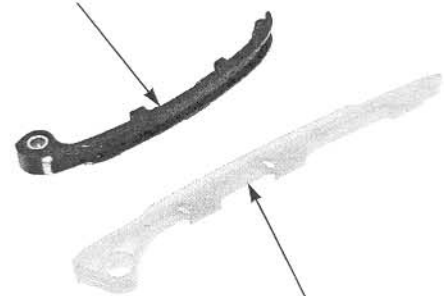

CAM CHAIN GUIDE A

CYLINDER HEAD/VALVES

Inspect the cam chain tensioner B for excessive wear or damage, replace it if necessary.

CAM CHAIN TENSIONER B

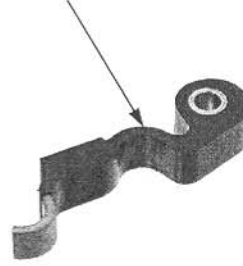

VALVE/VALVE GUIDE

Check that the valve moves smoothly in the guide. Inspect each valve for bending, burning or abnormal stem wear.

Measure and record each valve stem O.D.

SERVICE LIMITS:

IN: 3.965 mm (0.1561 in)

EX: 3.955 mm (0.1557 in)

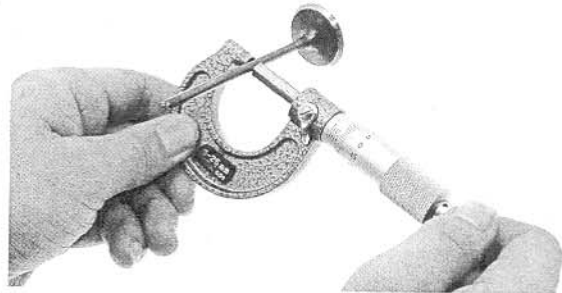

Ream the guides to remove any carbon deposits before checking clearances.

Insert the reamer from the combustion chamber side of the cylinder head and always rotate the reamer clockwise.

TOOL:

Valve guide reamer, 4.008 mm 07MMH-MV90100 or 07MMH-MV9010A (U.S.A. only)

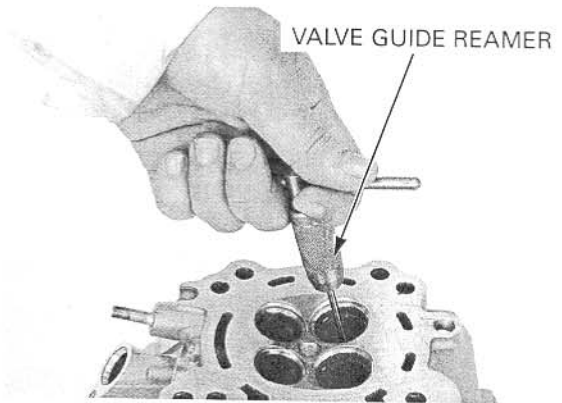

Measure and record each valve guide I.D.

SERVICE LIMIT: IN/EX: 4.04 mm (0.159 in)

Subtract each valve stem O.D. from the corresponding guide I.D. to obtain the stem-to-guide clearance.

SERVICE LIMITS:

IN: 0.075 mm (0.0030 in)

EX: 0.085 mm (0.0033 in)

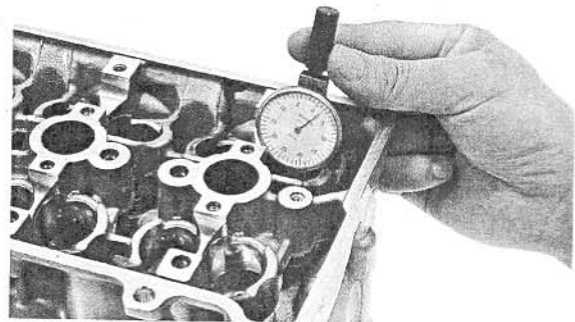

Reface the valve seats whenever the valve guides are replaced (page 9-20).

If the stem-to-guide clearance is out of standard, determine if a new guide with standard dimensions would bring the clearance within tolerance. If so, replace any guides as necessary and ream to fit. If the stem-to-guide clearance exceeds the service limit with the new guides, replace the valves and guides.

VALVE GUIDE REPLACEMENT

Chill the replacement valve guides in the freezer for about an hour.

Do not use a torch to heat the cylinder head; it may cause warping.

Heat the cylinder head to 100 – 150°C (212 – 300°F) with a hot plate or oven. To avoid burns, wear heavy gloves when handling the heated cylinder head.

Support the cylinder head and drive out the valve guides from combustion chamber side of the cylinder head.

TOOL:
Valve guide driver 07JMD-KY20100

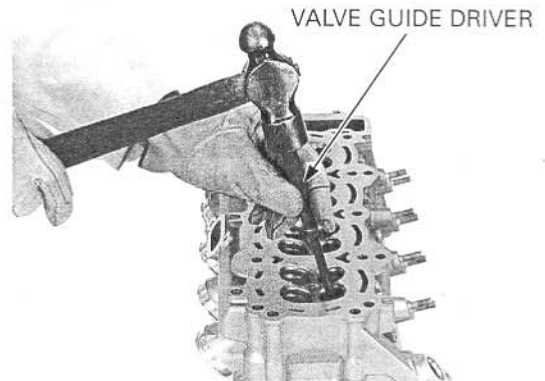

Drive in the guides to the specified depth from the top of the cylinder head.

SPECIFIED DEPTH:
IN: 17.1 – 17.4 mm (0.67 – 0.69 in)
EX: 13.3 – 13.6 mm (0.52 – 0.54 in)

TOOL:
Valve guide driver 07743-0020000
(not available in U.S.A.)

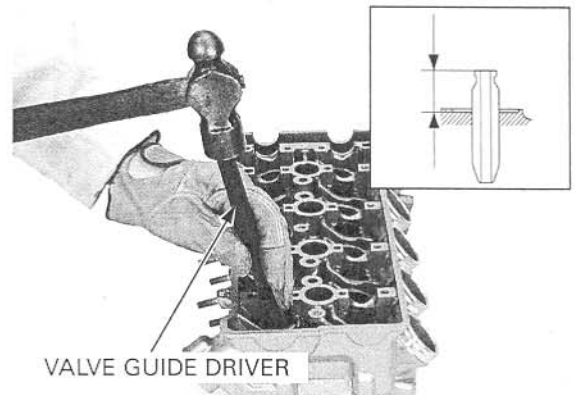

Let the cylinder head cool to room temperature.

Use cutting oil on the reamer during this operation.

Ream the new valve guides after installation. Insert the reamer from the combustion chamber side of the head and also always rotate the reamer clockwise.

TOOL:
Valve guide reamer, 4.008 mm 07MMH-MV90100 or 07MMH-MV9010A
(U.S.A. only)

Clean the cylinder head thoroughly to remove any metal particles.
Reface the valve seat (page 9-20).

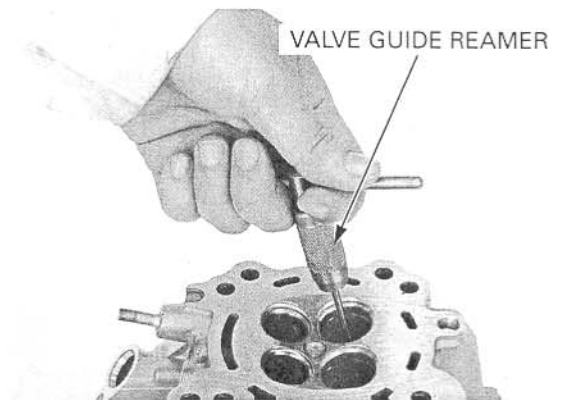

VALVE SEAT INSPECTION/REFACING

Clean the intake and exhaust valves thoroughly to remove carbon deposits.
Apply a light coating of Prussian Blue to the valve seats.
Tap the valves and seats using a rubber hose or other hand-lapping tool.

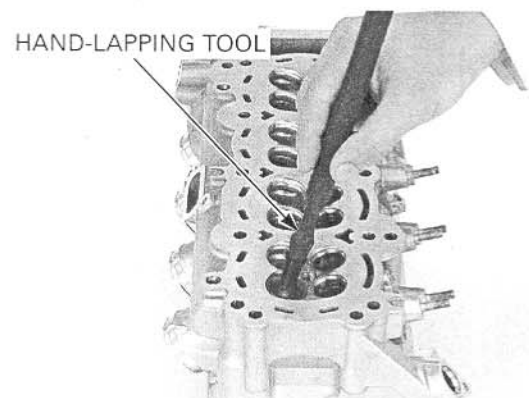

CYLINDER HEAD/VALVES

Remove the valve and inspect the valve seat face. The valve seat contact should be within the specified width and even all around the circumference.

STANDARD:

IN: 0.90 – 1.10 mm (0.035 – 0.043 in)

EX: 0.90 – 1.10 mm (0.035 – 0.043 in)

SERVICE LIMITS:

IN: 1.5 mm (0.06 in)

EX: 1.5 mm (0.06 in)

If the seat width is not within specification, reface the valve seat (page 9-20).

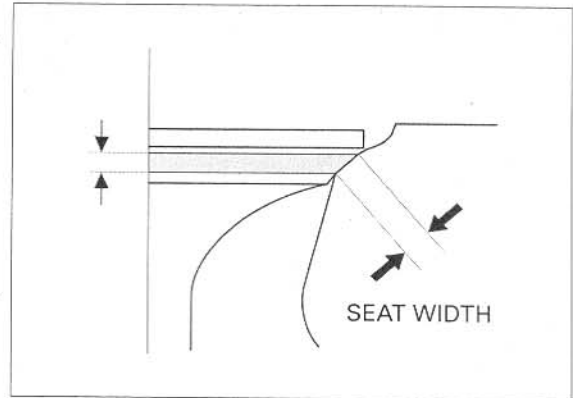

Inspect the valve seat face for:

- Uneven seat width:
 - Replace the valve and reface the valve seat.
- Damaged face:
 - Replace the valve and reface the valve seat.

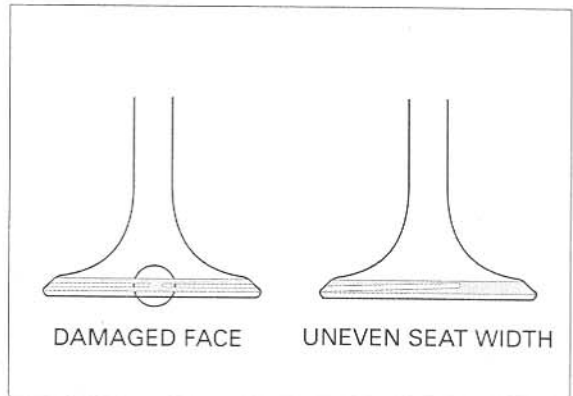

The valves cannot be ground. If a valve face is burned or badly worn or if it contacts the seat unevenly, replace the valve.

- Contact area (too high or too low)
 - Reface the valve seat.

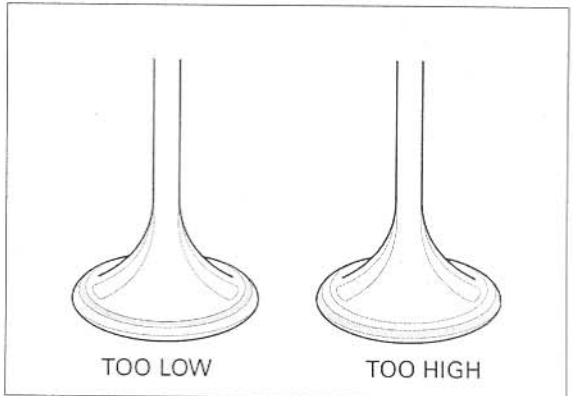

VALVE SEAT REFACING

Follow the refacing manufacturer's operating instructions.

Valve seat cutters/grinders or equivalent valve seat refacing equipment are recommended to correct worn valve seats.

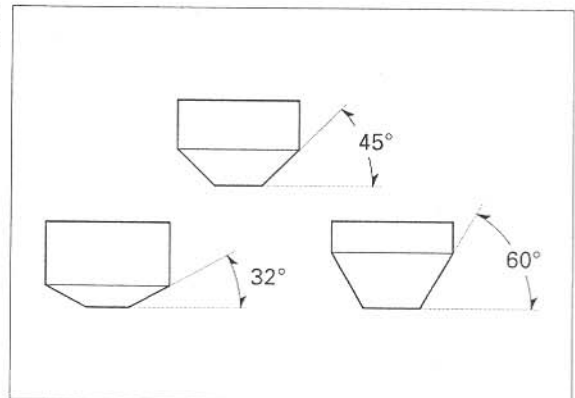

CYLINDER HEAD/VALVES

If the contact area is too high on the valve, the seat must be lowered using a 32-degree flat cutter.

If the contact area is too low on the valve, the seat must be raised using a 60-degree interior cutter.

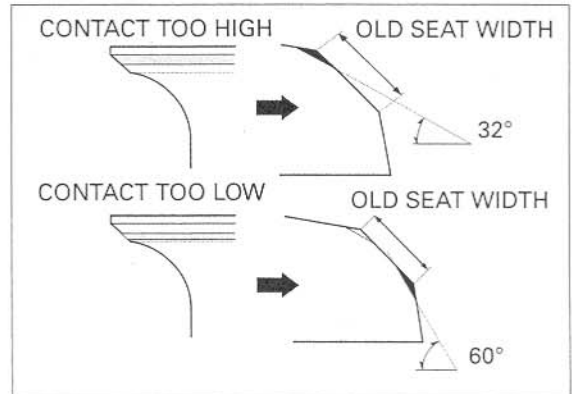

Reface the seat with a 45-degree cutter whenever a valve guide is replaced.

Use a 45-degree cutter to remove any roughness or irregularities from the seat.

TOOLS:

Seat cutter, 27.5 mm (IN)
 Seat cutter, 24 mm (EX)
 Cutter holder, 4.0 mm

07780-0010200
 07780-0010600
 07781-0010500 or
 equivalent commercially available in U.S.A.

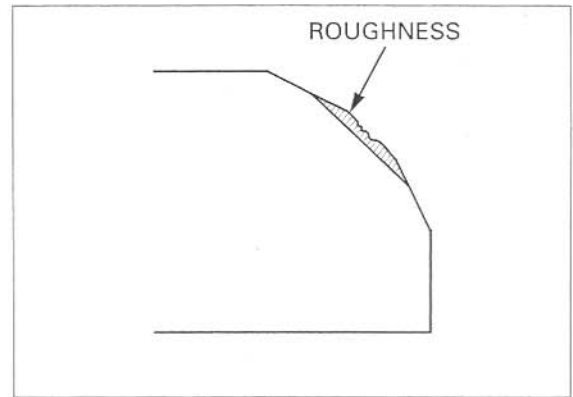

Use a 32-degree cutter to remove the top 1/4 of the existing valve seat material.

TOOLS:

Flat cutter, 30 mm (IN)
 Flat cutter, 24 mm (EX)
 Cutter holder, 4.0 mm

07780-0012200
 07780-0012500
 07781-0010500 or
 equivalent commercially available in U.S.A.

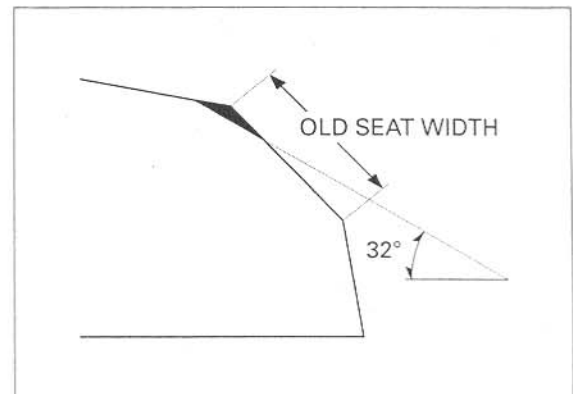

Use a 60-degree cutter to remove the bottom 1/4 of the old seat.

TOOLS:

Interior cutter, 26 mm (IN)
 Interior cutter, 22 mm (EX)
 Cutter holder, 4.0 mm

07780-0014500
 07780-0014202
 07781-0010500 or
 equivalent commercially available in U.S.A.

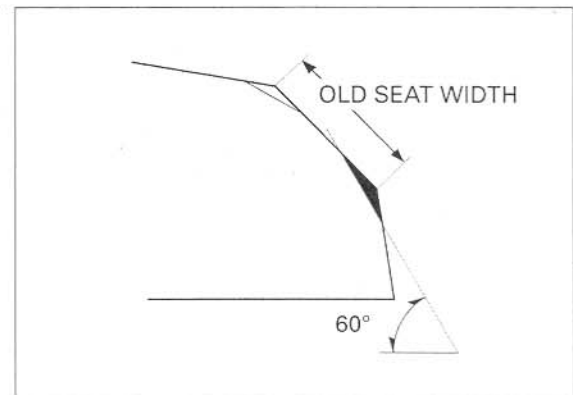

CYLINDER HEAD/VALVES

Using a 45-degree seat cutter, cut the seat to the proper width. Make sure that all pitting and irregularities are removed. Refinish if necessary.

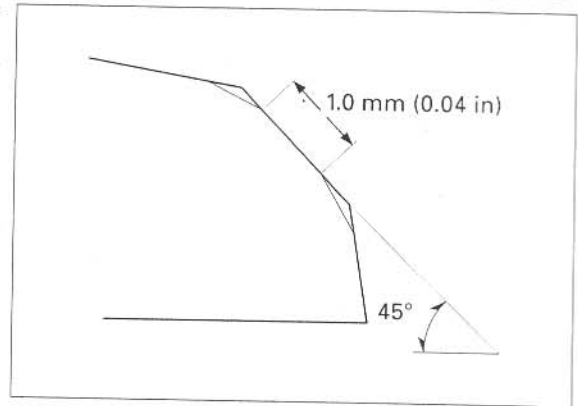

After cutting the seat, apply lapping compound to the valve face, and lap the valve using light pressure.

- Excessive lapping pressure may deform or damage the seat.
- Change the angle of lapping tool frequently to prevent uneven seat wear.
- Do not allow lapping compound to enter the guides.

After lapping, wash all residual compound off the cylinder head and valve.

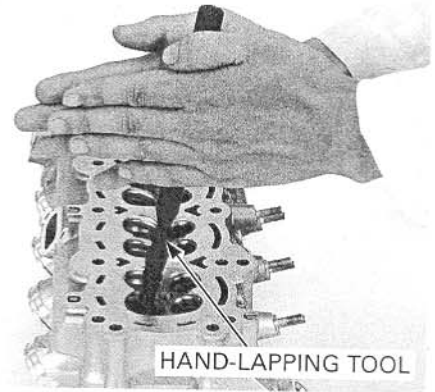

CYLINDER HEAD ASSEMBLY

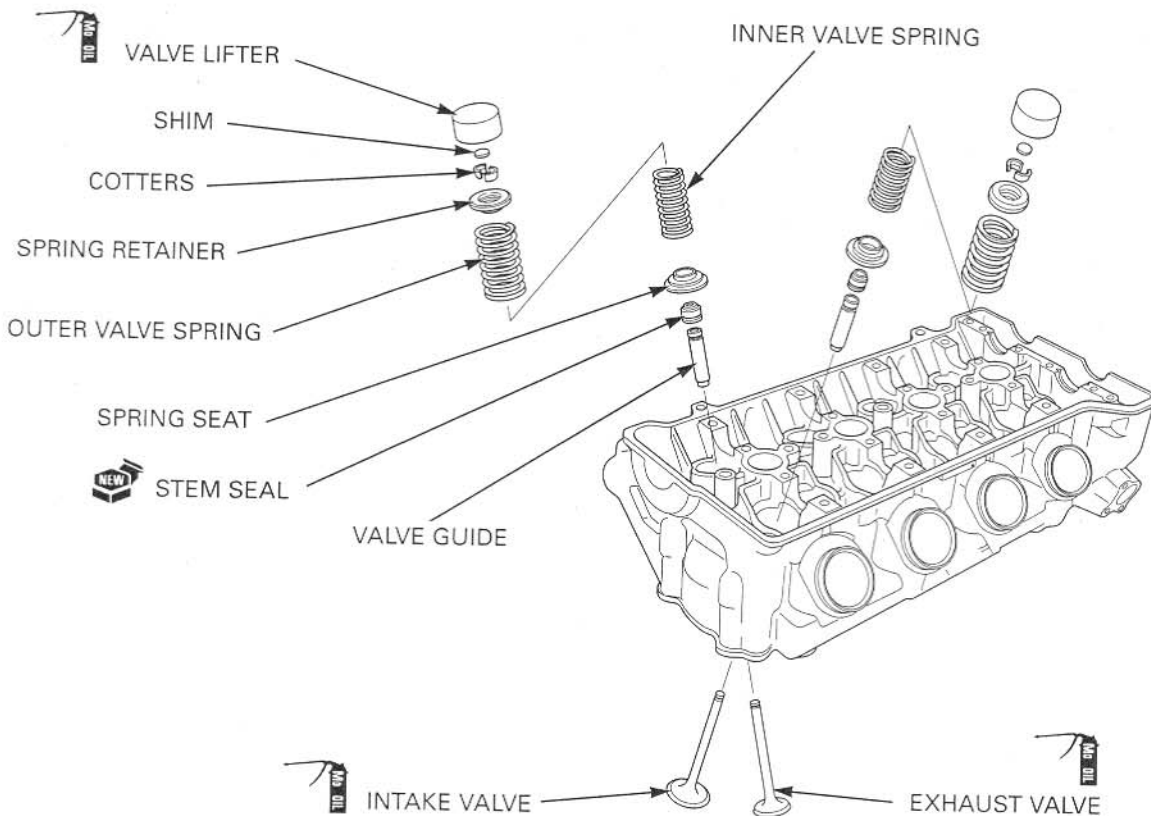

CYLINDER HEAD/VALVES

Blow through all oil passages in the cylinder head with compressed air.

Install the tappet hole protector into the valve lifter bore.

TOOL:

Tappet hole protector

07HMG-MR70002
(not available in U.S.A.) or refer to page 9-15 for alternative tool

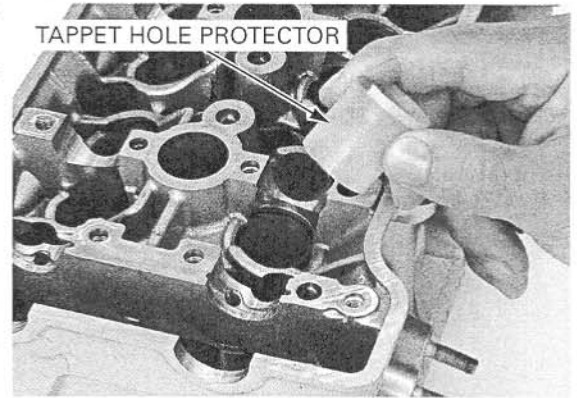

Install the valve spring seats.
Install the new stem seals.

Lubricate the valve stems with molybdenum oil solution.

Insert the valve into the valve guide while turning it slowly to avoid damage to the stem seal.

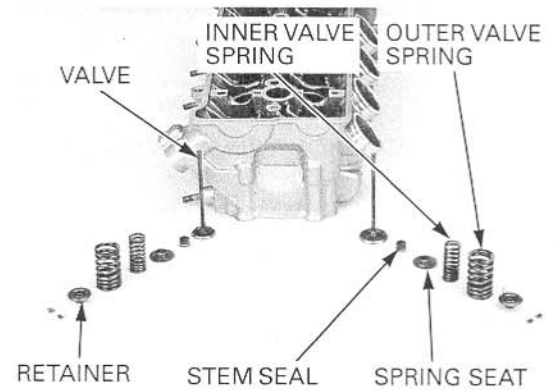

The exhaust valve springs has a orange paint marks and the intake valve springs has blue paint marks.

Install the valve springs with the tightly wound coils facing the combustion chamber.

Install the valve spring retainer.

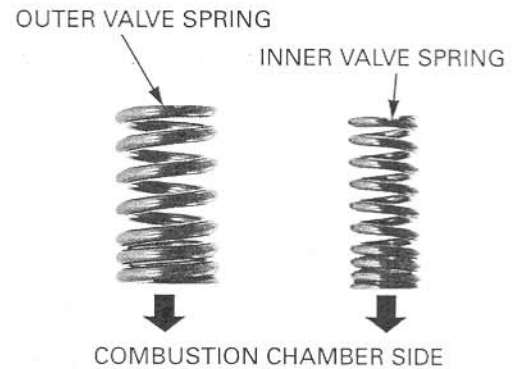

Grease the cotters to ease installation.

Install the valve cotters using the special tool as shown.

NOTE:

To prevent loss of tension, do not compress the valve spring more than necessary.

TOOLS:

Valve spring compressor

07757-0010000

Valve spring compressor attachment

07959-KM30101

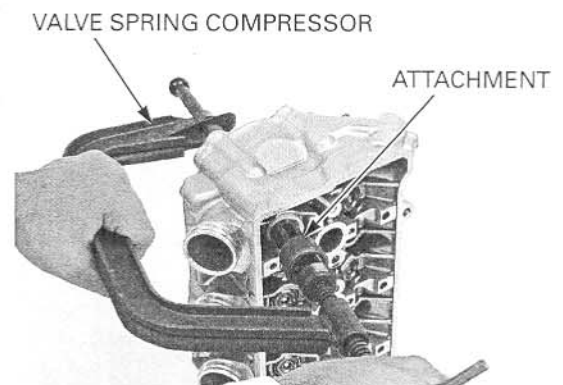

CYLINDER HEAD/VALVES

Support the cylinder head above the work bench surface to prevent possible valve damage.

Tap the valve stems gently with two plastic hammers as shown to seat the cotters firmly.

Install and tighten the spark plugs.

TORQUE: 16 N·m (1.6 kgf·m, 12 lbf·ft)

PLASTIC HAMMERS

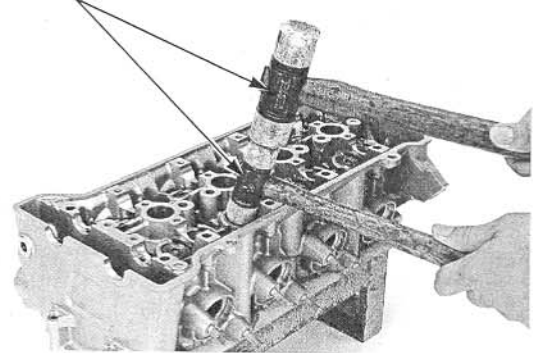

Apply a locking agent to the cam chain tensioner pivot bolt threads.

Install the sealing washer, bolt and cam chain tensioner B as shown.

Tighten the cam chain tensioner B pivot bolt to the specified torque.

TORQUE: 20 N·m (2.0 kgf·m, 14 lbf·ft)

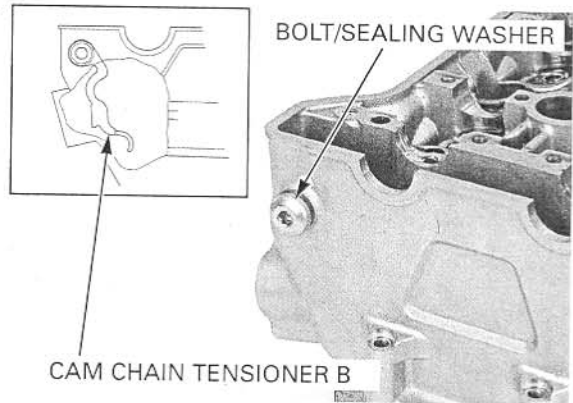

CYLINDER HEAD INSTALLATION

Install the timing sprocket by aligning the wide teeth between the crankshaft and sprocket.

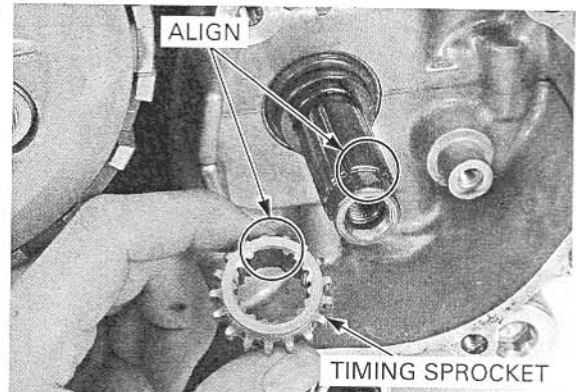

Install the cam chain.

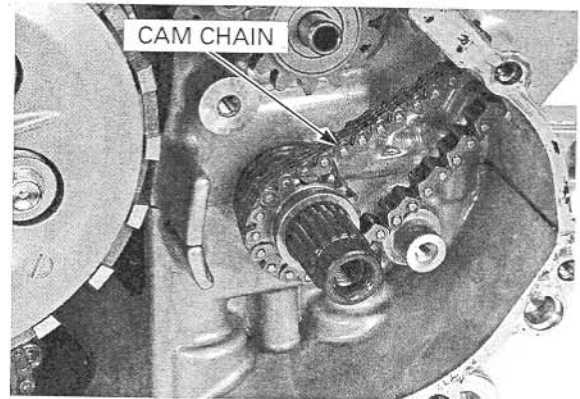

CYLINDER HEAD/VALVES

Install the cam chain guide A and bolt.

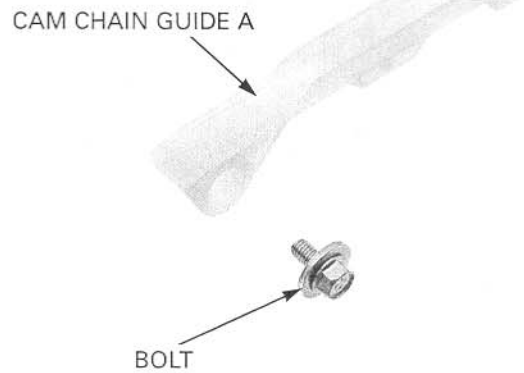

Apply a locking agent to the cam chain tensioner pivot bolt threads.
Install the washer, cam chain tensioner A and socket bolt.

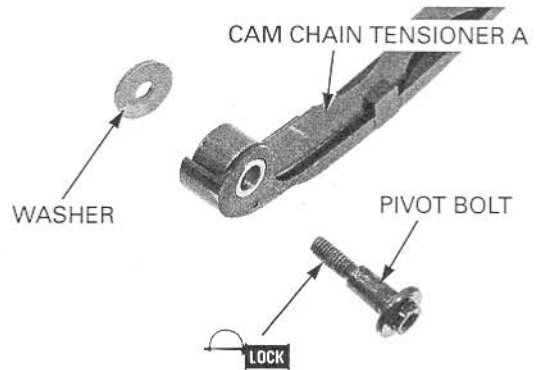

Tighten the cam chain guide A bolt to the specified torque.

TORQUE: 12 N·m (1.2 kgf·m, 9 lbf·ft)

Tighten the cam chain tensioner A pivot bolt to the specified torque.

TORQUE: 9.8 N·m (1.0 kgf·m, 7 lbf·ft)

Install the starter clutch (page 10-20) and right crankcase cover (page 10-24).

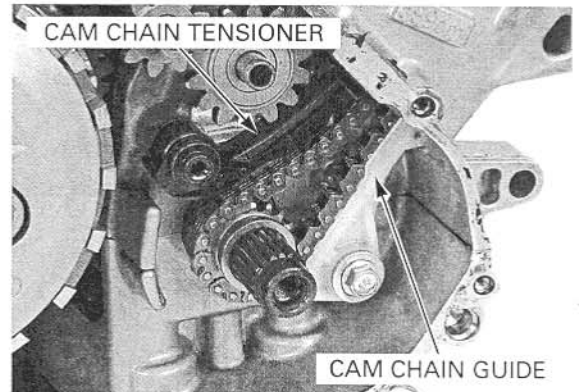

Install the dowel pins and a new cylinder head gasket as shown.

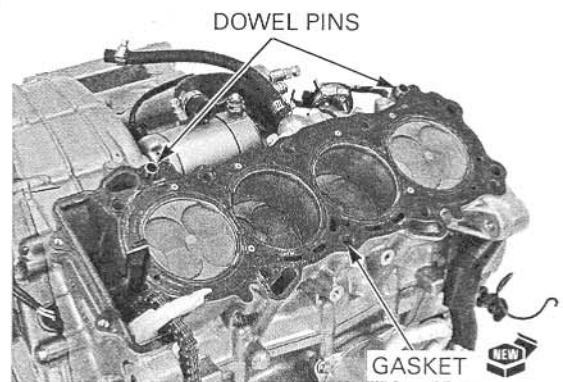

CYLINDER HEAD/VALVES

Install the cylinder head onto the cylinder block while aligning the cam chain tensioner A and B as shown.

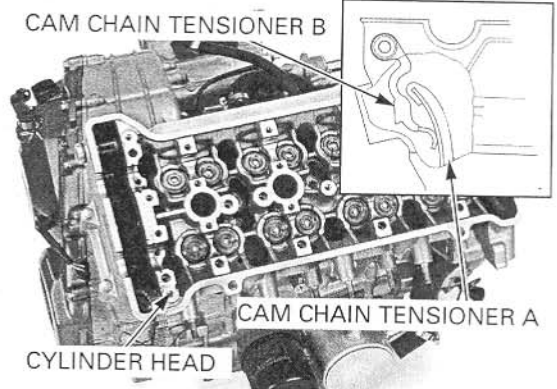

Apply molybdenum disulfide oil solution to the threads and seating surface of the 9 mm bolts/washers and install them.

Install the two 6 mm flange bolts.

Tighten the 9 mm bolts in a crisscross pattern in two or three steps to the specified torque.

TORQUE: 47 N·m (4.8 kgf·m, 35 lbf·ft)

Tighten the 6 mm flange bolts.

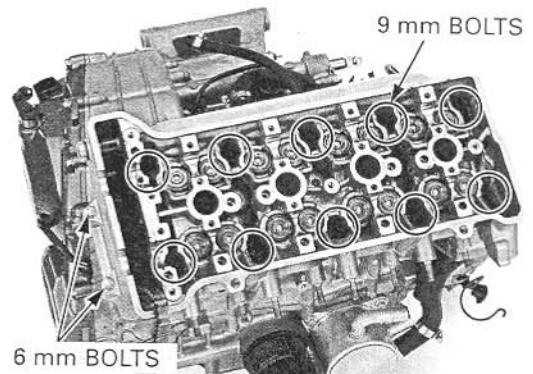

Install the cam chain tensioner lifter onto the cylinder head with a new gasket.

Install and tighten the socket bolts to the specified torque.

TORQUE: 9.8 N·m (1.0 kgf·m, 7 lbf·ft)

Install the engine into the frame (page 8-10).

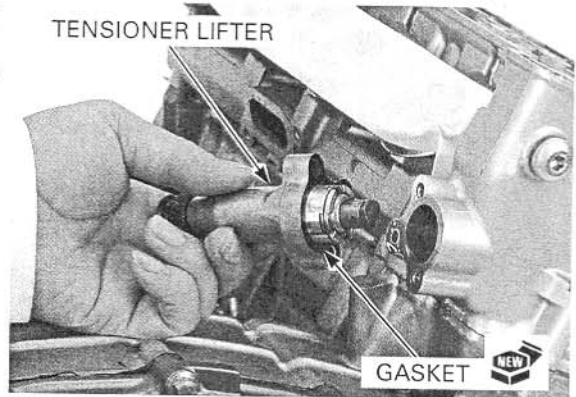

CAMSHAFT INSTALLATION

Apply molybdenum oil solution to the outer surface of the each valve lifter.

Install the shims and valve lifters in their original locations.

Install the shims on the retainers and valve lifters into the valve lifter bores.

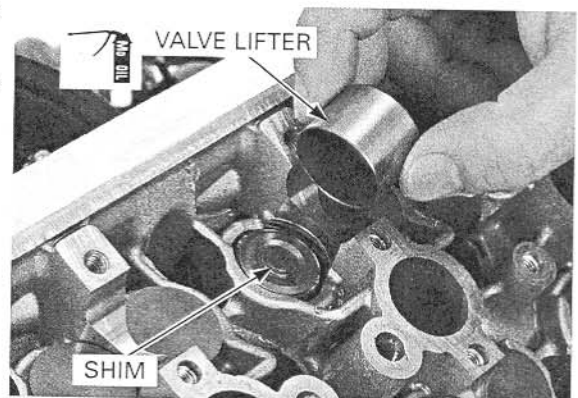

CYLINDER HEAD/VALVES

If the cam sprockets are removed, install the cam sprockets onto the camshafts.

- Install the intake cam sprocket with the timing mark (IN) facing outward and the No.1 cam lobes facing up and out as shown.
- Install the exhaust cam sprocket with the timing mark (EX) facing outward and the No.1 cam lobes facing up and out as shown.

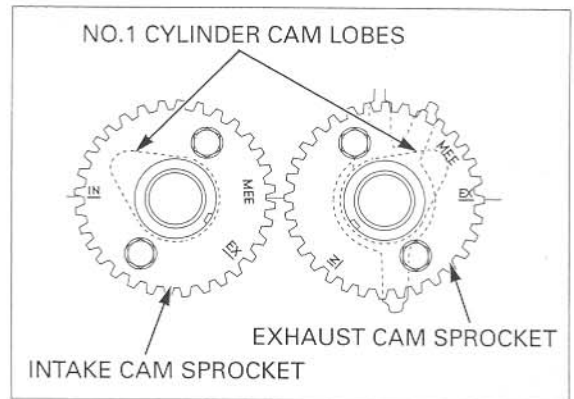

Clean and apply a locking agent to the cam sprocket bolt threads.
Install the cam sprockets and bolts.

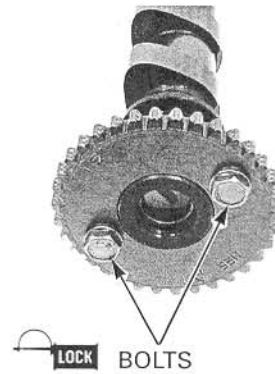

Exhaust camshaft only: Clean and apply a locking agent to the cam pulse generator rotor bolt threads.

Install the cam pulse generator rotor with the No.1 cylinder cam lobes facing down and rotor "OUT" mark facing up as shown. Install the cam pulse generator rotor and bolts.

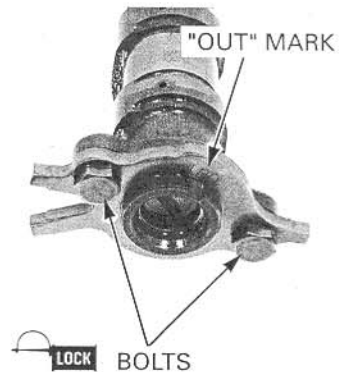

Turn the crankshaft clockwise and align the "T" mark on the ignition pulse generator rotor with the index mark on the right crankcase cover.

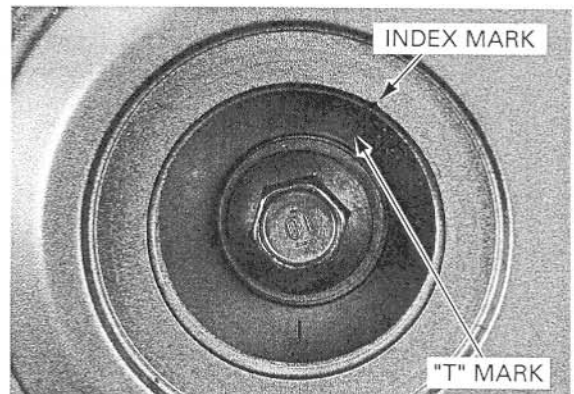

CYLINDER HEAD/VALVES

Apply molybdenum oil solution to the camshaft journal of the cylinder head.

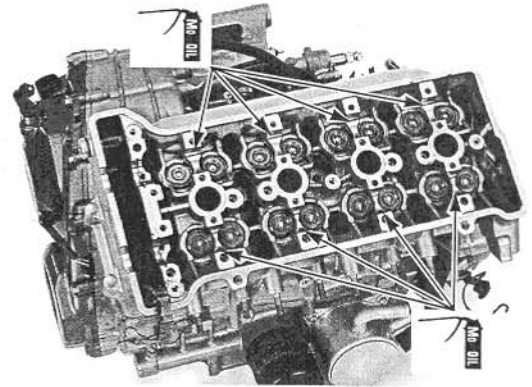

Install the cam chain over the cam sprockets and then install the intake and exhaust camshafts.

- Install the each camshaft to the correct locations with the identification marks.
"IN": Intake camshaft
"EX": Exhaust camshaft

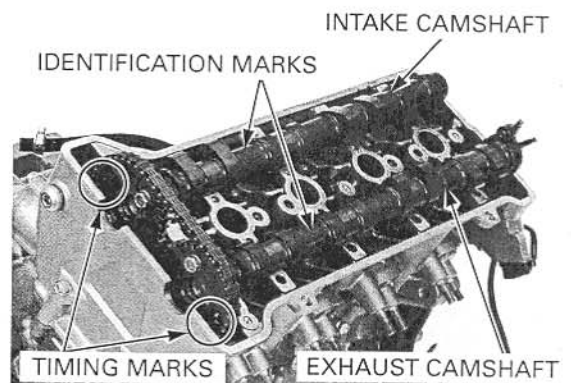

- Make sure that the timing marks on the cam sprockets are facing outward and flush with the cylinder head upper surface as shown.

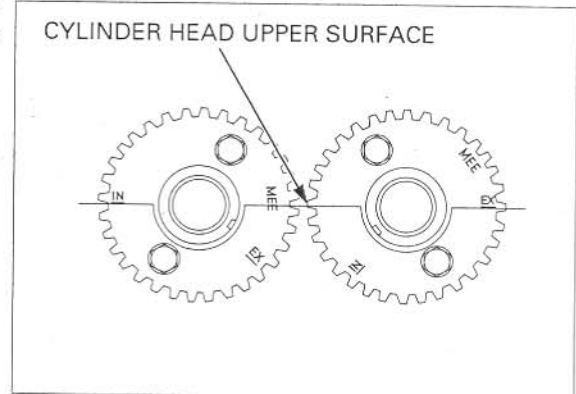

Coat new O-rings with oil and install them into the grooves in the camshaft holders.

Apply molybdenum oil solution to the camshaft journals of the camshaft holders.

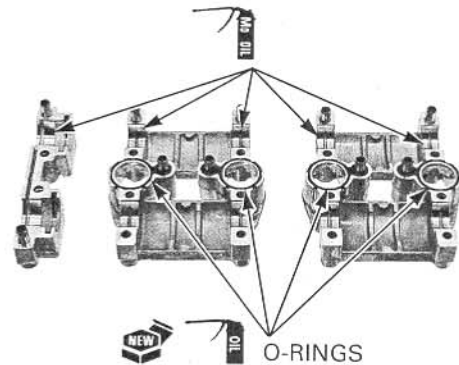

CYLINDER HEAD/VALVES

Be sure to align the dowel pins in the camshaft holder align properly with the holes in the cylinder head properly.

Install the each camshaft holder onto the camshafts.

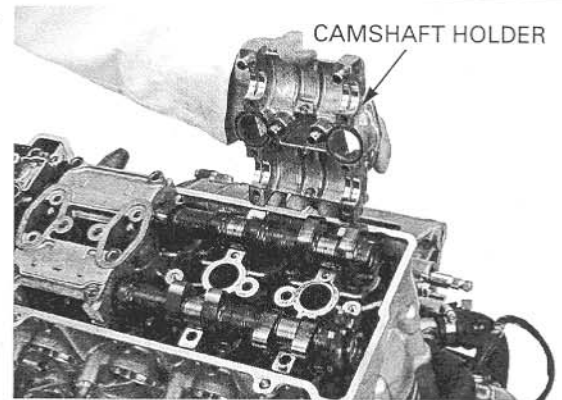

Note the correct locations with the identification marks as shown.

- No mark: right camshaft holder
- "R" mark: center camshaft holder
- "L" mark: left camshaft holder

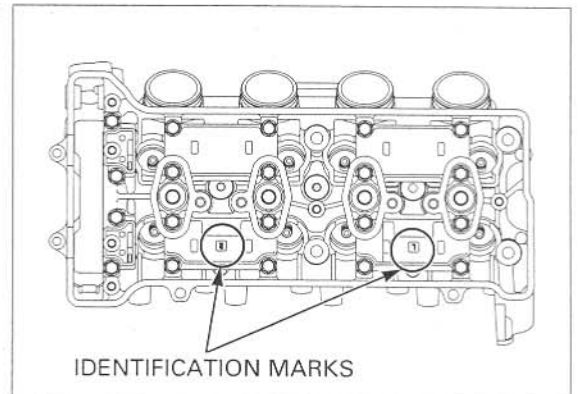

Apply engine oil to the threads and seating surfaces of the camshaft holder bolts. Install the twenty holder bolts with new eight sealing washers as shown.

Finger tighten the bolts.

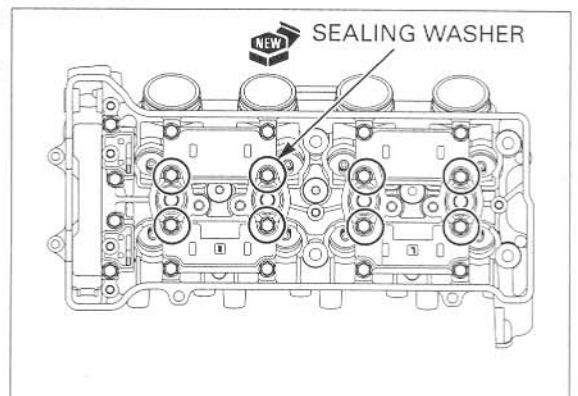

First gradually tighten the four bolts (No.5 – No.6 – No.7 – No.8) in the numerical order cast on the camshaft holders. Gradually tighten the other camshaft holder bolts until the camshaft holders lightly contact the cylinder head surface.

NOTICE

Failure to tighten the camshaft holder in a criss-cross pattern might cause a camshaft holder to break.

Tighten all camshaft holder bolts in the numerical order casted on the camshaft holders.

TORQUE: 12 N·m (1.2 kgf·m, 9 lbf·ft)

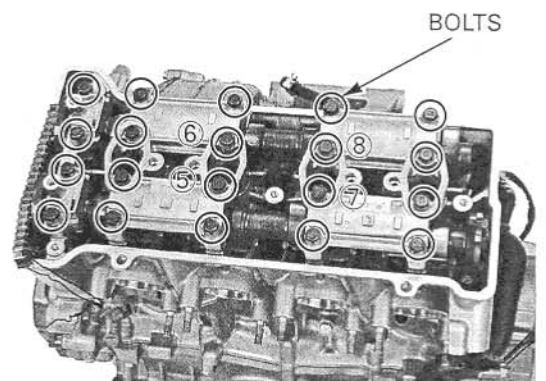

CYLINDER HEAD/VALVES

Install the cam chain guide B, and tighten the bolts.

BOLTS

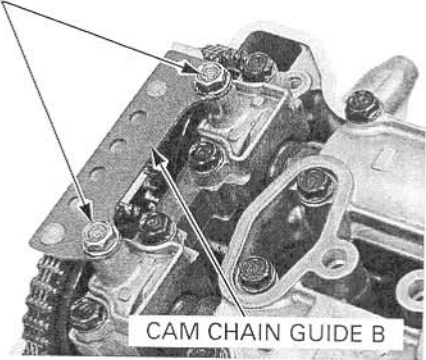

In case the cam sprockets were removed, tighten the cam sprocket bolts to the specified torque.

TORQUE: 20 N·m (2.0 kgf·m, 14 lbf·ft)

Turn the crankshaft clockwise one full turn (360°) and tighten the other cam sprocket bolts.

CAM SPROCKET BOLTS

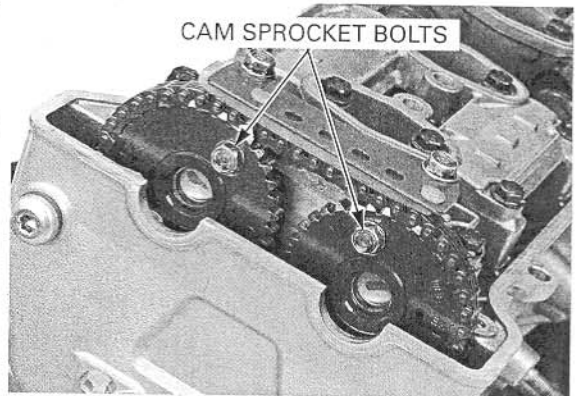

In case the cam pulse generator rotor was removed, tighten the cam pulse generator rotor bolts to the specified torque.

TORQUE: 12 N·m (1.2 kgf·m, 9 lbf·ft)

CAM PULSE GENERATOR ROTOR

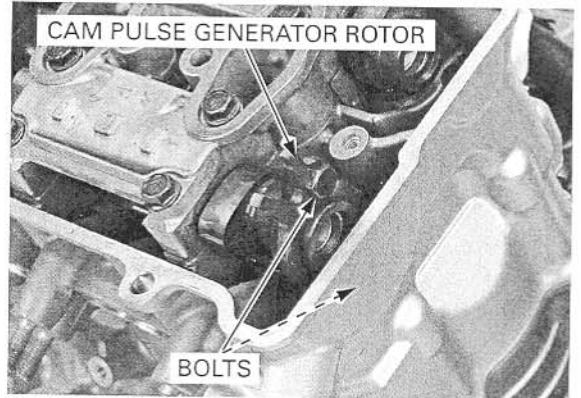

Remove the special tool from the cam chain tensioner lifter.

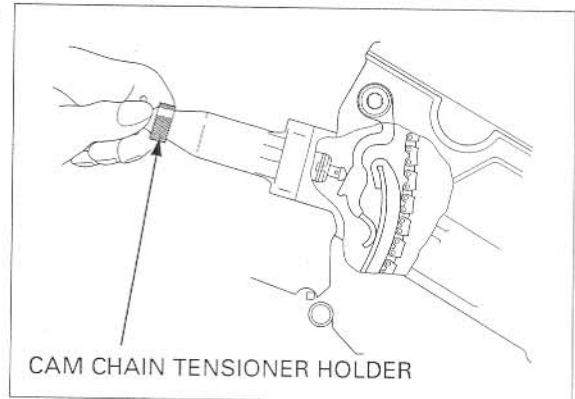

CYLINDER HEAD/VALVES

Install a new sealing washer and tighten the sealing bolt.

Recheck the valve timing.

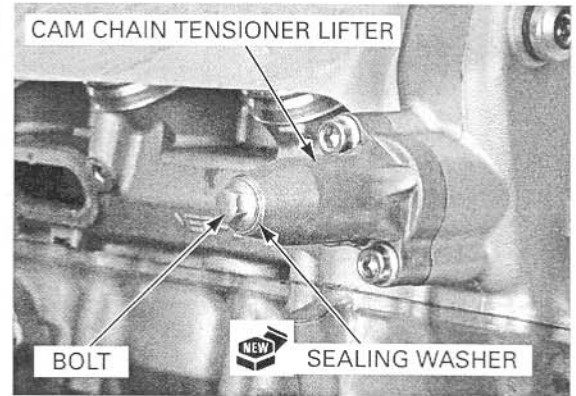

Apply oil to a new O-ring, and install it onto the cam pulse generator.

Install the cam pulse generator into the cylinder head.

Install and tighten the mounting bolt, clamp securely.

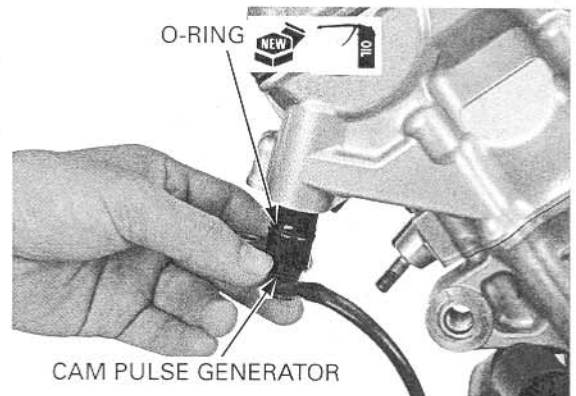

CYLINDER HEAD COVER ASSEMBLY

Install a new gasket and crankcase breather plate onto the cylinder head cover.

Apply a locking agent to the crankcase breather plate bolt threads. Install and tighten the bolts to the specified torque.

TORQUE: 13 N·m (1.3 kgf·m, 9 lbf·ft)

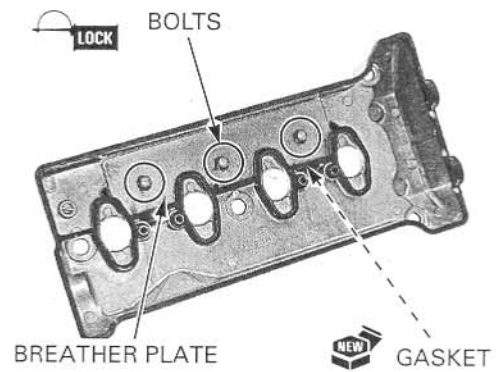

Install the PAIR check valve port plates into the cylinder head cover.

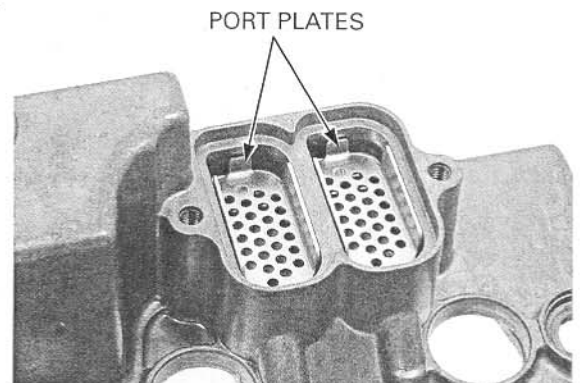

CYLINDER HEAD/VALVES

Install the PAIR check valves into the cylinder head cover.

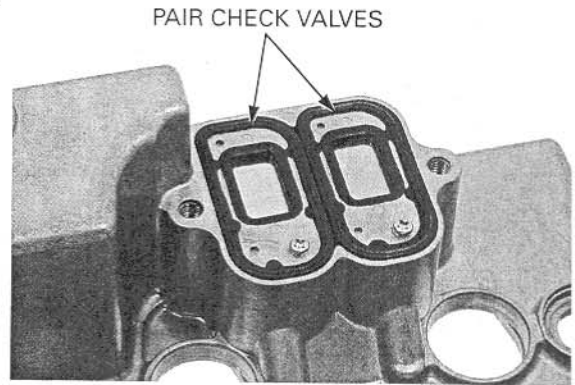

Install the PAIR check valve cover and tighten the bolts to the specified torque.

TORQUE: 13 N·m (1.3 kgf·m, 9 lbf·ft)

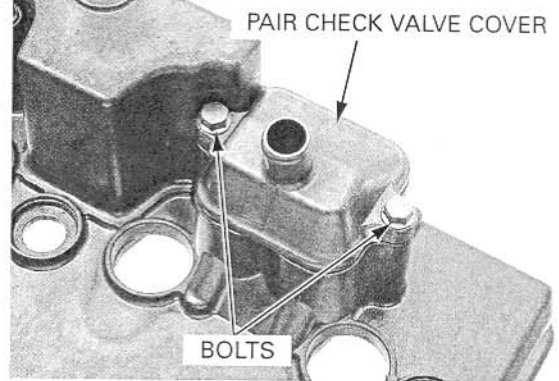

CYLINDER HEAD COVER INSTALLATION

Install the cylinder head packing into the groove of the cylinder head cover.

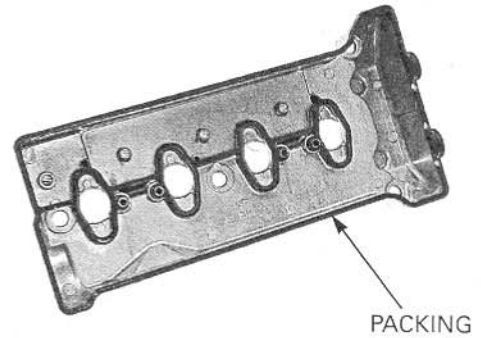

Apply sealant to the cylinder head semi-circular cut-outs as shown.

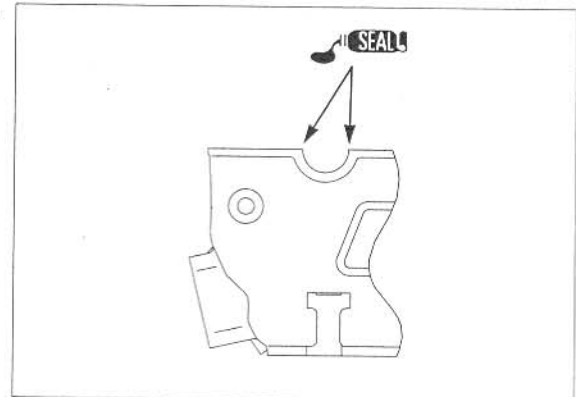

CYLINDER HEAD/VALVES

Install the cylinder head cover onto the cylinder head.

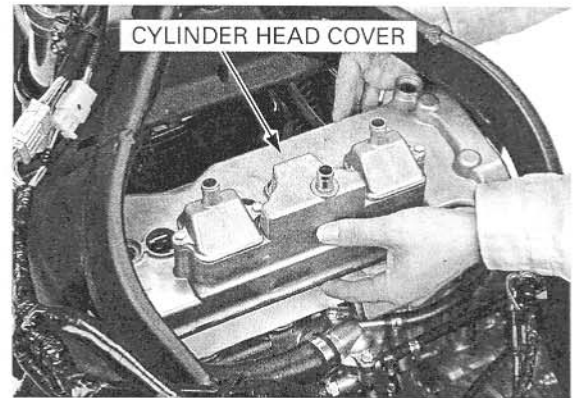

Install the washers to the cylinder head cover with their "UP" mark facing up.

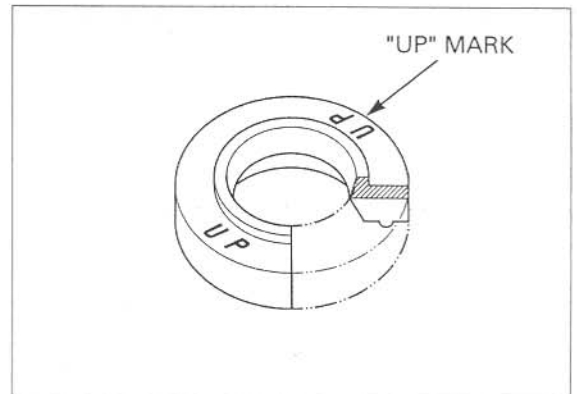

Install and tighten the cylinder head cover bolts to the specified torque.

TORQUE: 9.8 N·m (1.0 kgf·m, 7 lbf·ft)

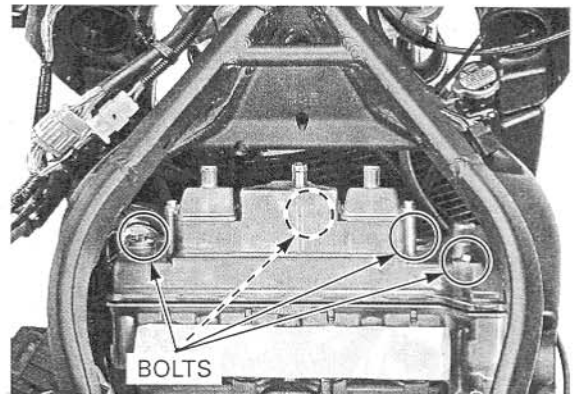

Install the heat guard rubber.

Connect the PAIR air hoses onto the cylinder head and install the PAIR control solenoid valve.

Connect the PAIR control solenoid valve 2P (Black) connector.

Install the crankcase breather hose.

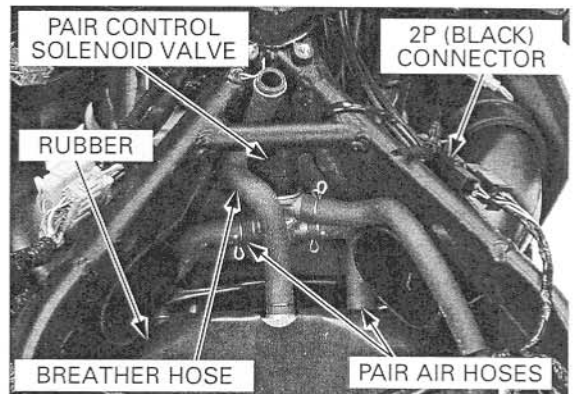

CYLINDER HEAD/VALVES

Install the direct ignition coils and connect the ignition coil connectors.

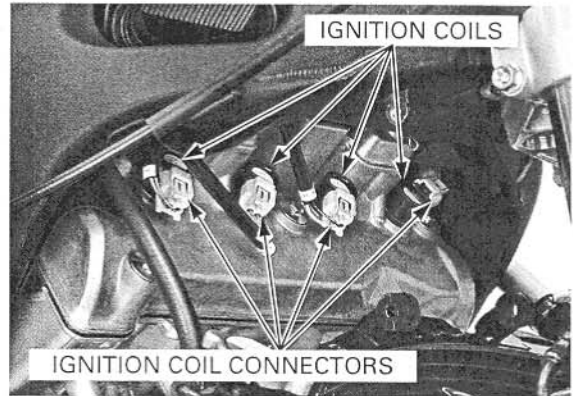

CAM CHAIN TENSIONER LIFTER

REMOVAL

Remove the following:

- Lower cowls (page 3-6)
- Middle cowls (page 3-7)
- Tool box (page 6-73)

Remove the cam chain tensioner sealing bolt and sealing washer.

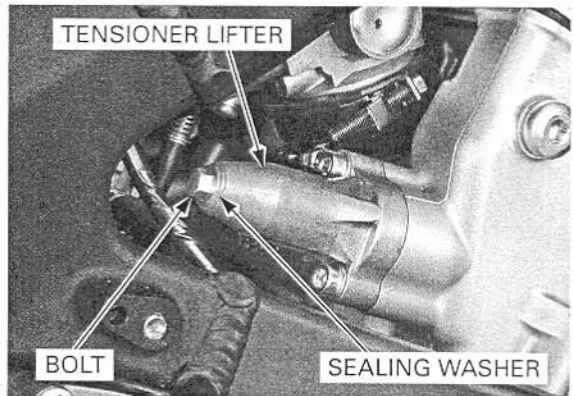

Turn the tensioner shaft fully in (clockwise) and secure it using the special tool to prevent damaging the cam chain.

TOOL:

Cam chain tensioner holder 07ZMG-MCAA400

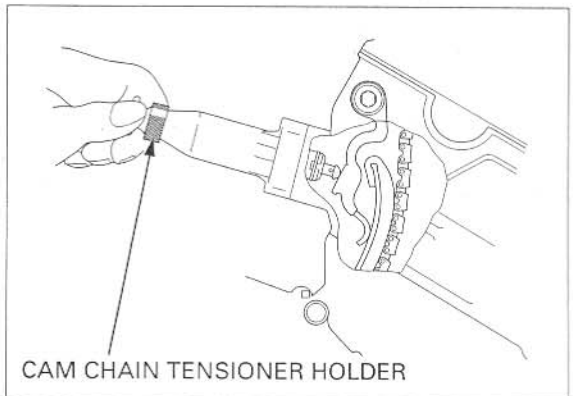

Remove the socket bolts, cam chain tensioner lifter and gasket.

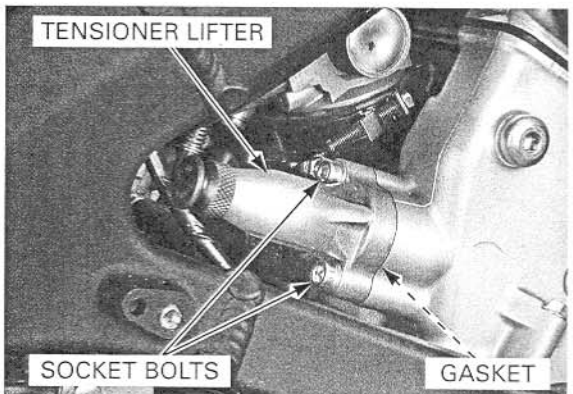

INSTALLATION

Note the installation direction of the gasket.

Install a new gasket onto the cam chain tensioner lifter.
 Install the cam chain tensioner lifter into the cylinder head.

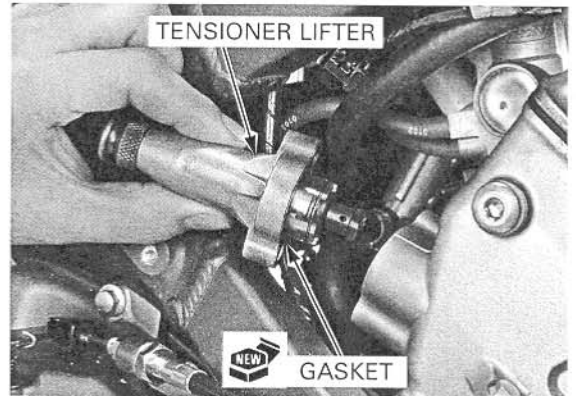

Install and tighten the socket bolts to the specified torque.

TORQUE: 9.8 N·m (1.0 kgf·m, 7 lbf·ft)

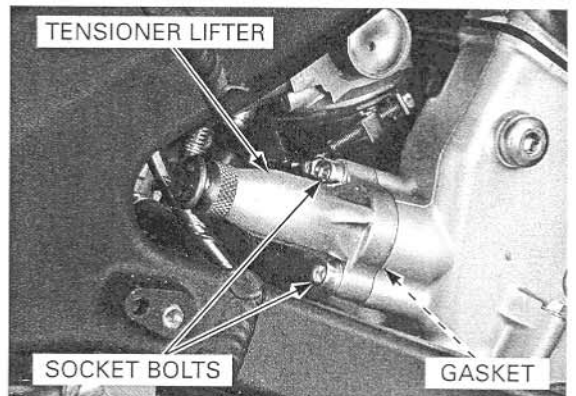

Remove the special tool.

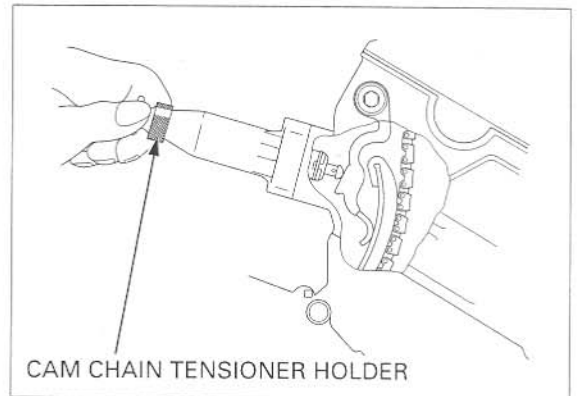

Install a new sealing washer and tighten the sealing bolt securely.

Installation is the removed parts in the reverse order of removal.

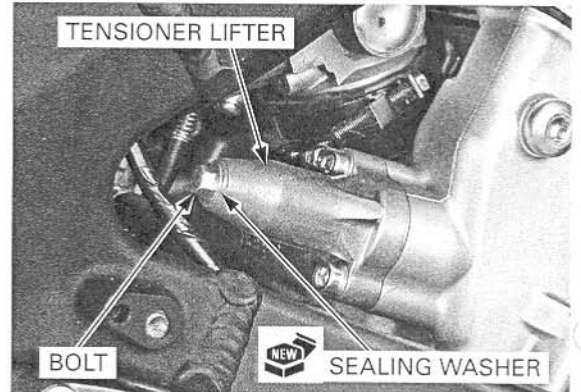

10. CLUTCH/STARTER CLUTCH/GEARSHIFT LINKAGE

COMPONENT LOCATION.....	10-2	CLUTCH.....	10-7
SERVICE INFORMATION.....	10-3	STARTER CLUTCH.....	10-17
TROUBLESHOOTING.....	10-4	GEARSHIFT LINKAGE.....	10-22
RIGHT CRANKCASE COVER REMOVAL....	10-5	RIGHT CRANKCASE COVER INSTALLATION.....	10-24

CLUTCH/STARTER CLUTCH/GEARSHIFT LINKAGE COMPONENT LOCATION

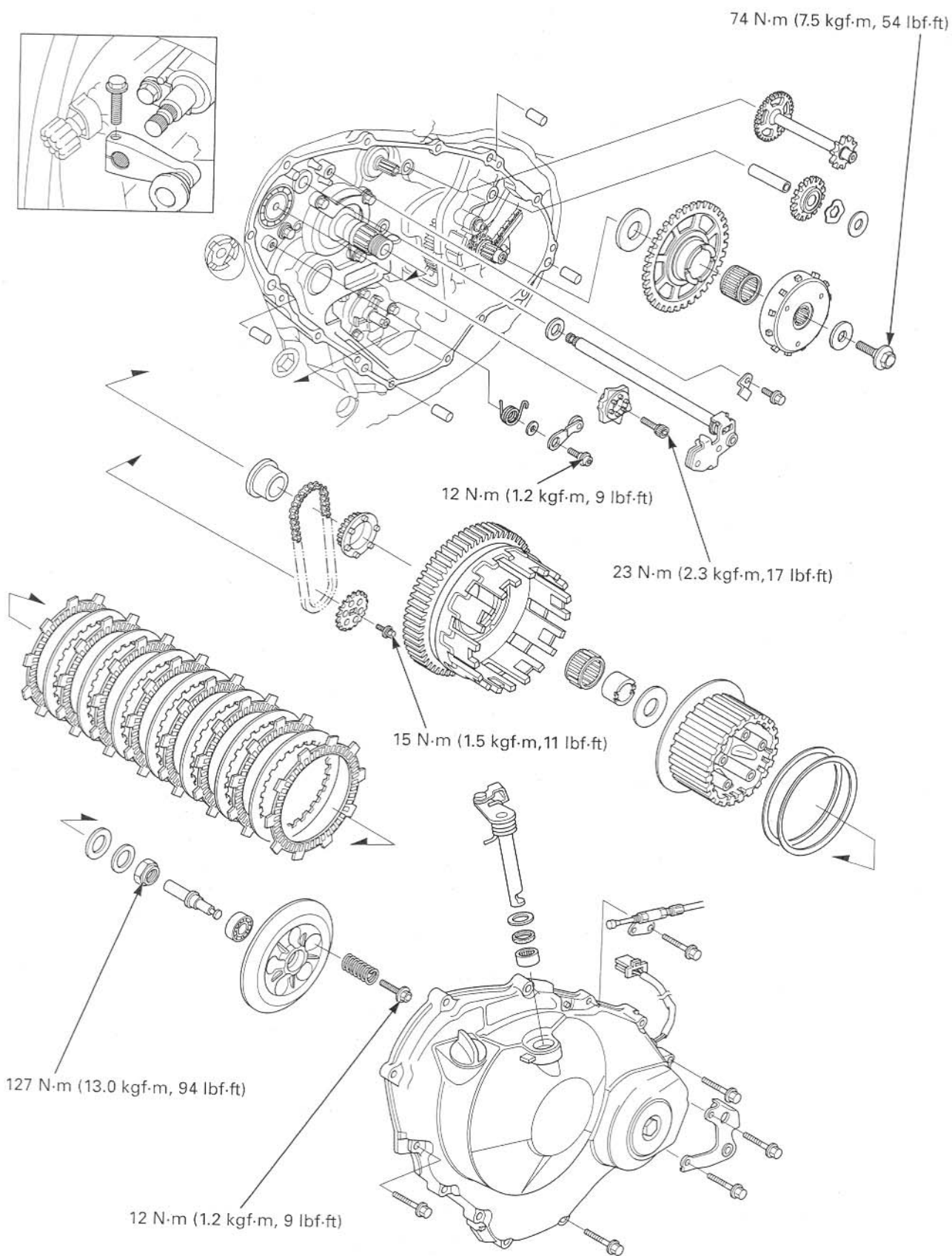

CLUTCH/STARTER CLUTCH/GEARSHIFT LINKAGE

SERVICE INFORMATION

GENERAL

- This section covers service of the clutch, starter clutch and gearshift linkage. All service can be done with the engine installed in the frame.
- Engine oil viscosity and level have an effect on clutch disengagement. When the clutch does not disengage or the motorcycle creeps with clutch disengaged, inspect the engine oil level before servicing the clutch system.

SPECIFICATIONS

Unit: mm (in)

ITEM		STANDARD	SERVICE LIMIT
Clutch lever free play		10 – 20 (3/8 – 13/16)	–
Clutch	Spring free length	46.5 (1.83)	45.2 (1.78)
	Disc thickness	2.92 – 3.08 (0.115 – 0.121)	2.6 (0.10)
	Plate warpage	–	0.30 (0.012)
Clutch outer guide A (Without ID mark)	I.D.	24.993 – 25.003 (0.9840 – 0.9844)	25.013 (0.9848)
	O.D.	35.004 – 35.012 (1.3781 – 1.3784)	34.994 (1.3777)
Clutch outer guide B (With ID mark)	I.D.	24.993 – 25.003 (0.9840 – 0.9844)	25.013 (0.9848)
	O.D.	34.996 – 35.004 (1.3778 – 1.3781)	34.986 (1.3774)
Primary driven gear I.D.	A	41.008 – 41.016 (1.6145 – 1.6148)	41.026 (1.6152)
	B	41.000 – 41.008 (1.6142 – 1.6145)	41.018 (1.6149)
Oil pump drive sprocket guide	I.D.	25.000 – 25.021 (0.9843 – 0.9851)	25.031 (0.9855)
	O.D.	34.950 – 34.975 (1.3760 – 1.3770)	34.940 (1.3756)
Oil pump drive sprocket I.D.		35.025 – 35.145 (1.3789 – 1.3837)	35.155 (1.3841)
Mainshaft O.D. at clutch outer guide		24.980 – 24.990 (0.9835 – 0.9839)	24.960 (0.9827)
Mainshaft O.D. at oil pump drive sprocket guide		24.980 – 24.990 (0.9835 – 0.9839)	24.960 (0.9827)
Starter driven gear boss O.D.		45.657 – 45.673 (1.7975 – 1.7981)	45.642 (1.7969)

TORQUE VALUES

Clutch center lock nut	127 N·m (13.0 kgf·m, 94 lbf·ft)	Apply oil to the thread Stake the nut
Clutch spring bolt	12 N·m (1.2 kgf·m, 9 lbf·ft)	
Oil pump driven sprocket bolt	15 N·m (1.5 kgf·m, 11 lbf·ft)	Apply a locking agent to the threads
Shift drum center socket bolt	23 N·m (2.3 kgf·m, 17 lbf·ft)	Apply a locking agent to the threads
Shift drum stopper arm pivot bolt	12 N·m (1.2 kgf·m, 9 lbf·ft)	
Gearshift spindle return spring pin	22 N·m (2.2 kgf·m, 16 lbf·ft)	
Starter clutch outer special bolt	74 N·m (7.5 kgf·m, 54 lbf·ft)	Apply oil to the threads and flange surface

TOOLS

<p>Clutch center holder 07724-0050002</p>  <p>or equivalent commercially available in U.S.A.</p>	<p>Gear holder, M2.5 07724-0010100</p> 
---	--

CLUTCH/STARTER CLUTCH/GEARSHIFT LINKAGE

TROUBLESHOOTING

Clutch lever too hard to pull in

- Damaged clutch lifter mechanism
- Faulty clutch lifter bearing
- Clutch lifter piece installed improperly

Clutch slips when accelerating

- Worn clutch disc
- Weak clutch springs
- Engine oil mixed with molybdenum or graphite additive

Clutch will not disengage or motorcycle creeps with clutch disengaged

- Clutch plate warped
- Loose clutch center lock nut
- Oil level too high
- Improper oil viscosity
- Damaged clutch lifter mechanism
- Clutch lifter piece installed improperly

Hard to shift

- Improper clutch operation
- Improper oil viscosity
- Bent shift fork
- Bent shift fork shaft (page 12-9)
- Bent fork claw (page 12-9)
- Damaged gearshift cam (page 12-9)
- Loose stopper plate bolt
- Damaged stopper plate and pin
- Damaged gearshift spindle

Transmission jumps out of gear

- Worn shift drum stopper arm
- Weak or broken shift drum stopper arm return spring
- Loose stopper plate bolt
- Bent shift fork shaft
- Damaged gearshift cam (page 12-9)
- Damaged or bent shift forks (page 12-9)
- Worn gear engagement dogs or slots (page 12-9)

Gearshift pedal will not return

- Weak or broken gearshift spindle return spring
- Bent gearshift spindle

Engine does not turn

- Faulty starter clutch
- Damaged reduction gear/shaft
- Damaged idle gear/shaft

RIGHT CRANKCASE COVER REMOVAL

Remove the following:

- Lower cowls (page 3-6)
- Middle cowls (page 3-7)
- Radiator reserve tank (page 7-17)

Drain the engine oil (page 4-16).

Lift and support the fuel tank (page 6-61).

Disconnect the ignition pulse generator 2P (Red) connector.

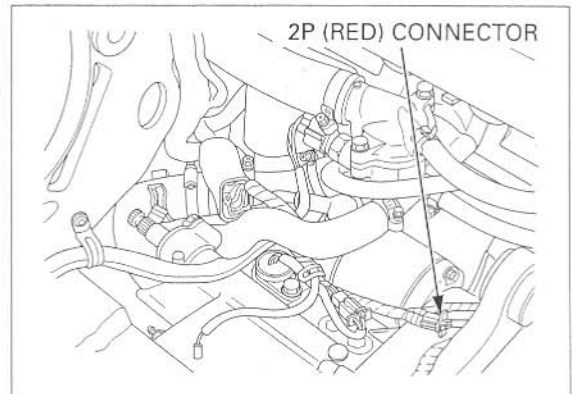

Remove the bolt and clutch cable guide plate, then disconnect the clutch cable end from the clutch lifter lever.

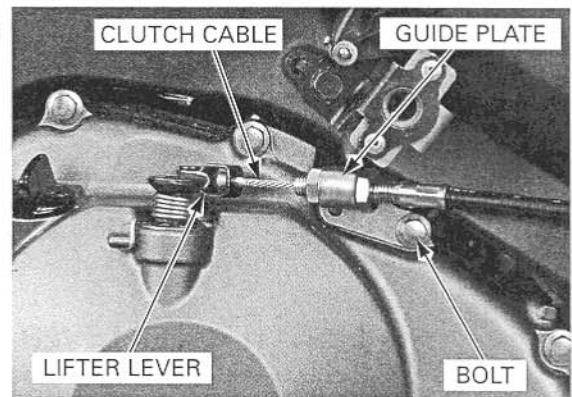

Remove the right crankcase cover bolts and radiator reserve tank mounting stay.

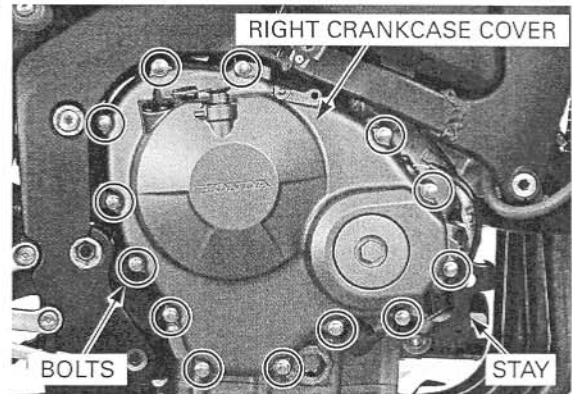

The lifter lever spindle is engaged with the clutch lifter piece inside of the right crankcase cover.

Remove the right crankcase cover while turning the clutch lifter lever counterclockwise to disengage the lifter lever spindle from the lifter piece.

NOTE:

Be careful not to drop the thrust/wave washers into the crankcase when removing the right crankcase cover.

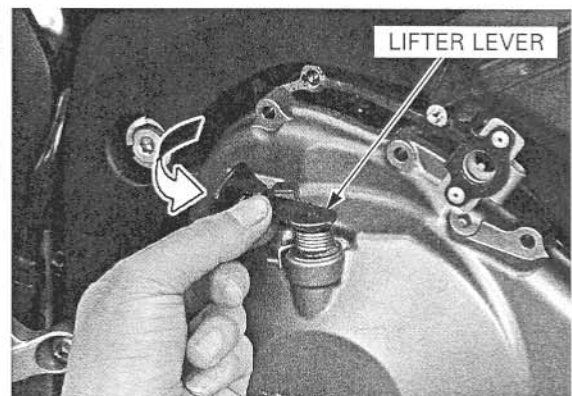

CLUTCH/STARTER CLUTCH/GEARSHIFT LINKAGE

Be careful not to drop the thrust/wave washers into the crankcase. Remove the thrust washer and wave washer from the starter idle gear.

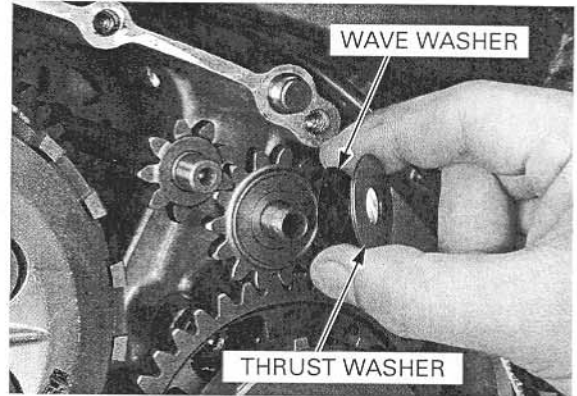

Remove the four dowel pins.

Clean off any sealant from the right crankcase cover mating surfaces.

NOTE:

Do not turn the crankshaft counterclockwise after removing the right crankcase cover to prevent the starter reduction gear from damage.

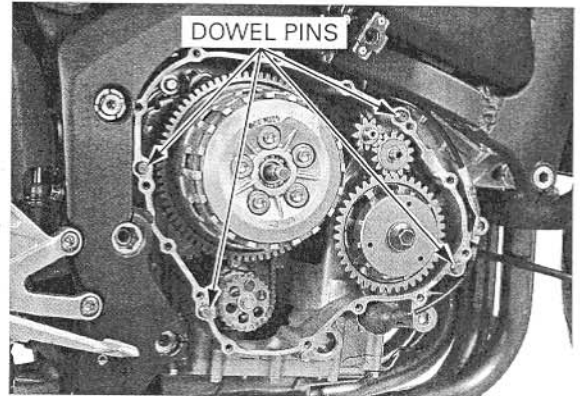

CLUTCH LIFTER LEVER

Remove the clutch lifter lever, return spring and washer from the right crankcase cover.

Check the lifter lever spindle for wear or damage. Check the return spring for fatigue or damage.

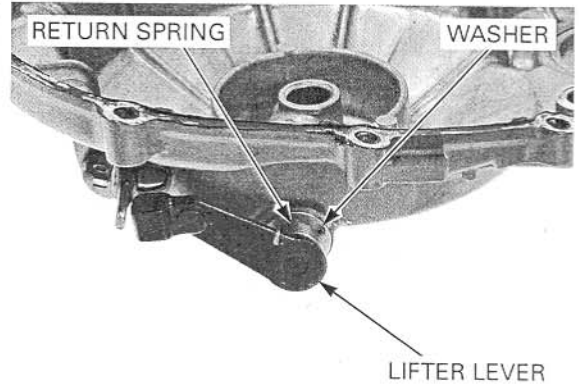

Check the lifter lever oil seal and needle bearings for wear or damage.

Install the clutch lifter lever with the washer and spring in the reverse order of removal.

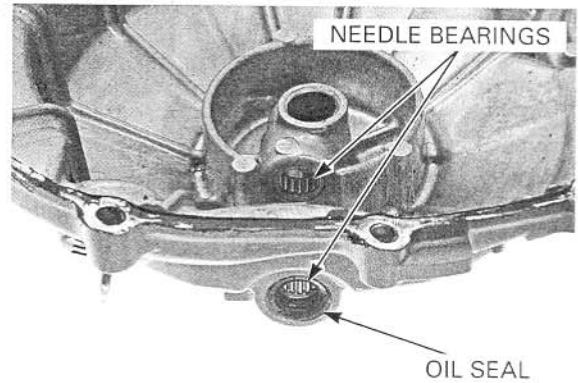

CLUTCH

REMOVAL

Remove the right crankcase cover (page 10-5).
Remove the starter idle gear and shaft.

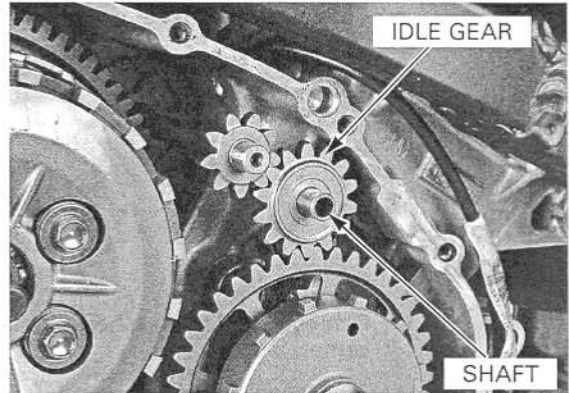

Remove the clutch spring bolts, springs in a criss-cross pattern in two to three steps, then remove the pressure plate.

Remove the clutch lifter piece from the lifter bearing.

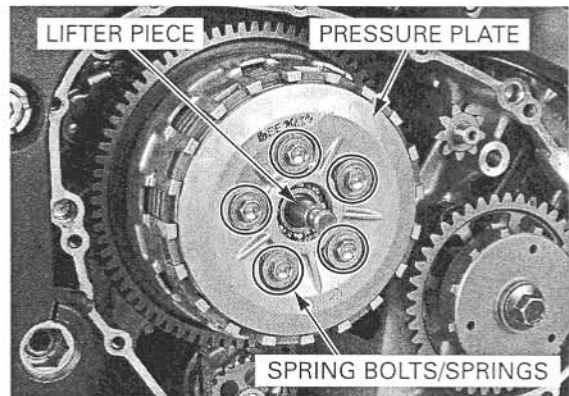

Remove the following:

- Clutch disc A
- Six clutch discs
- Seven clutch plates
- Clutch disc B
- Friction spring
- Spring seat

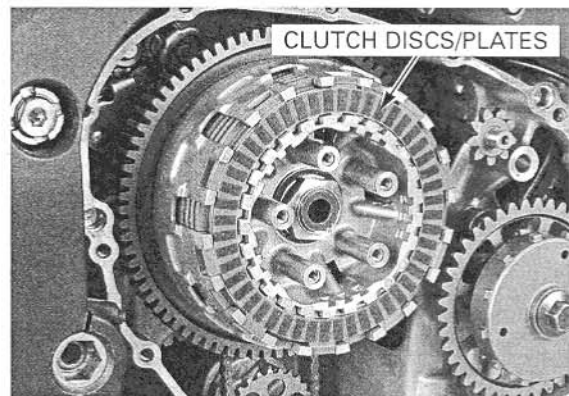

Unstake the clutch center lock nut.

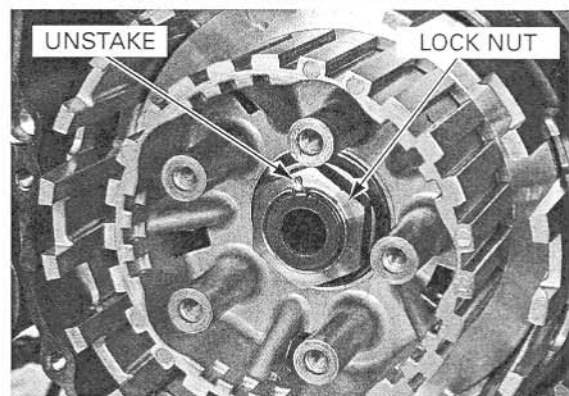

CLUTCH/STARTER CLUTCH/GEARSHIFT LINKAGE

Hold the clutch center with the special tool and remove the clutch center lock nut.

TOOL:

Clutch center holder

07724-0050002 or equivalent commercially available in U.S.A.

Discard the lock nut.

Remove the lock washer, thrust washer and clutch center.

Remove the thrust washer.

Remove the clutch outer guide and needle bearing.

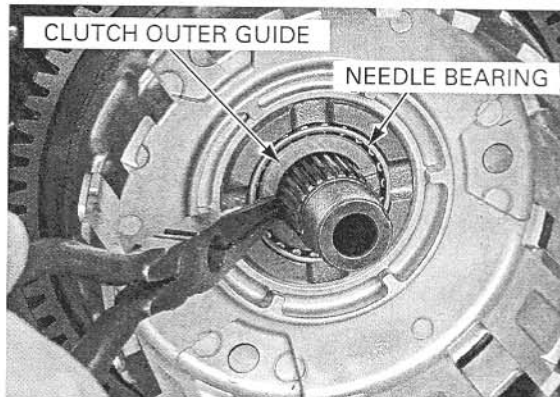
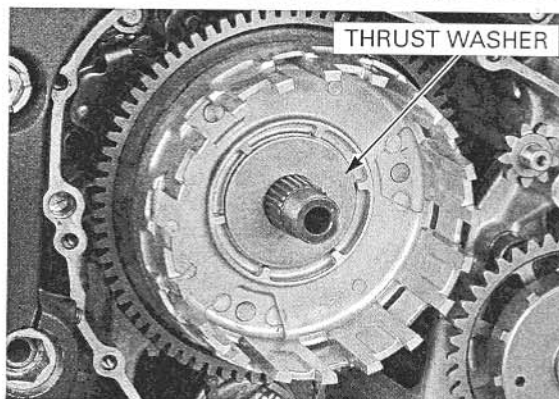
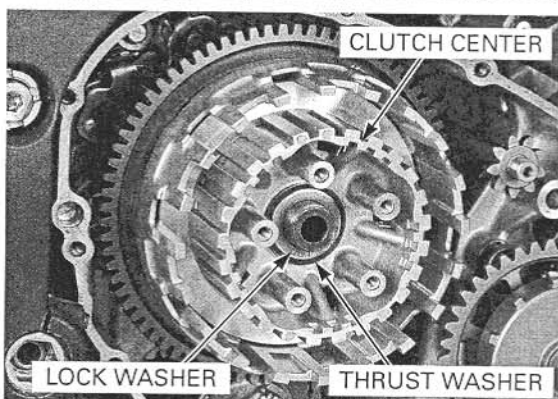
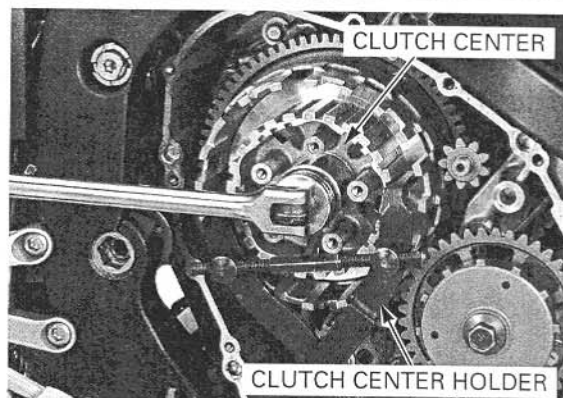

CLUTCH/STARTER CLUTCH/GEARSHIFT LINKAGE

Remove the clutch outer.

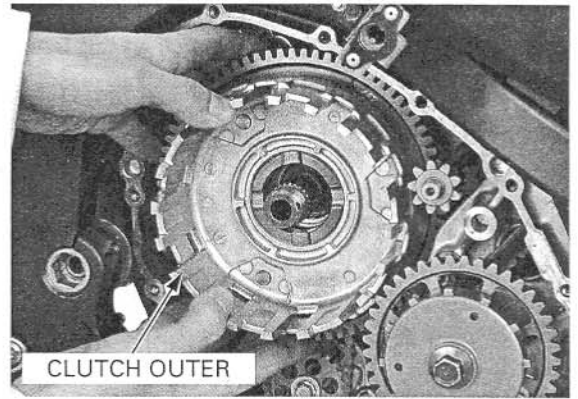

Remove the oil pump driven sprocket bolt. Remove the oil pump drive/driven sprocket and drive chain as an assembly.

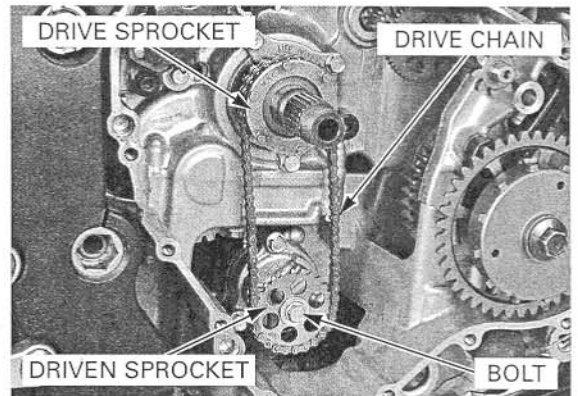

Remove the oil pump drive sprocket guide.

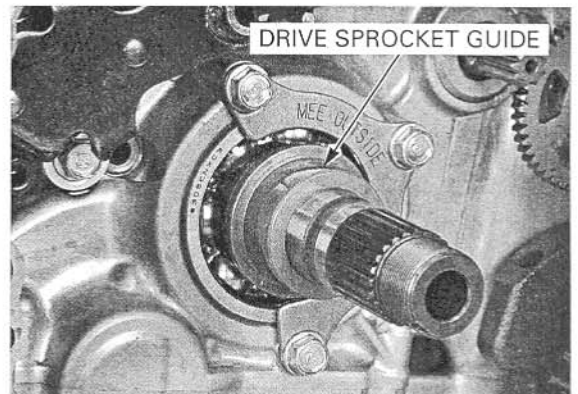

INSPECTION

Clutch lifter bearing

Turn the inner race of the lifter bearing with your finger.

The bearing should turn smoothly and freely without excessive play.

If necessary, replace the bearing.

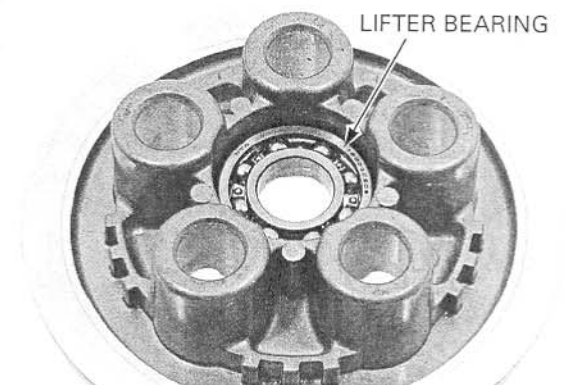

CLUTCH/STARTER CLUTCH/GEARSHIFT LINKAGE

Clutch spring

Replace the clutch springs as a set.

Measure the clutch spring free length.

SERVICE LIMIT: 45.2 mm (1.78 in)

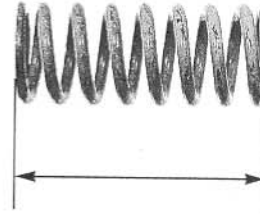

Clutch center

Check the grooves of the clutch center for damage or wear caused by the clutch plates. Replace it if necessary.

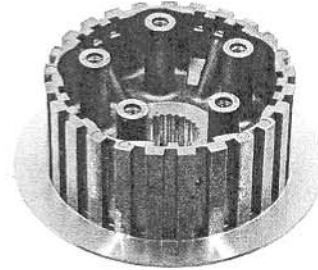

Clutch lifter piece

Check the clutch lifter piece for damage or abnormal wear.



Clutch disc

Replace the clutch discs and plates as a set.

Replace the clutch discs if they show signs of scoring or discoloration.

Measure the disc thickness of each disc.

SERVICE LIMIT: 2.6 mm (0.10 in)

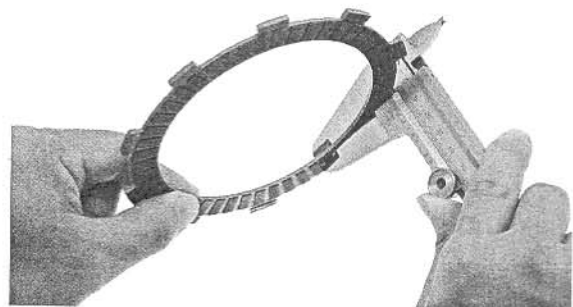

CLUTCH/STARTER CLUTCH/GEARSHIFT LINKAGE

Clutch plate

Replace the clutch discs and plates as a set.

Check the plates for discoloration.
Check the plate warpage on a surface plate using a feeler gauge.

SERVICE LIMIT: 0.30 mm (0.012 in)

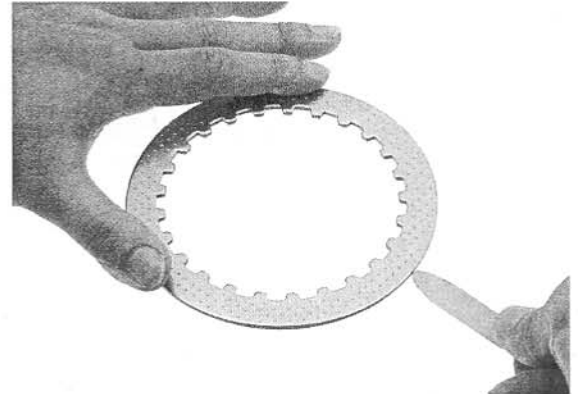

Friction spring/spring seat

Check the friction spring and spring seat for deformation, warpage or damage; replace as necessary.

- A damaged or warped spring seat will cause the friction spring to be pressed unevenly.
- A damaged friction spring also causes the weak contact between the discs and plates or uneven disc/plate contact.



SPRING SEAT



FRICITION SPRING

Clutch outer/primary driven gear

Check the slots of the clutch outer for damage or wear caused by the clutch discs.

Check the primary driven gear for abnormal wear or damage.

Measure the I.D. of the primary driven gear.

SERVICE LIMITS:

A: 41.026 mm (1.6152 in)

B: 41.018 mm (1.6149 in)

Replace the clutch outer assembly if necessary.

When the clutch outer assembly is replaced, be sure to select the needle bearing according to the selective fit table (page 10-12).

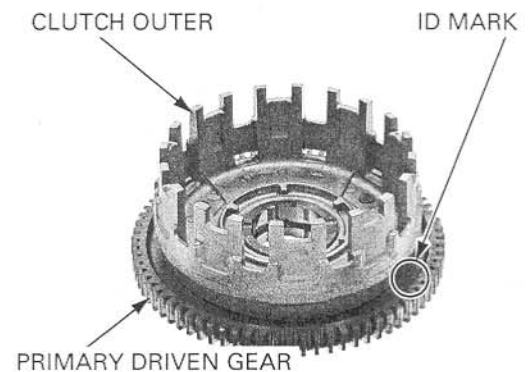

Clutch outer guide/needle bearing

Measure the O.D. and I.D. of the clutch outer guide.

SERVICE LIMITS:

A (without ID mark):

O.D.: 34.994 mm (1.3777 in)

I.D.: 25.013 mm (0.9848 in)

B (with ID mark):

O.D.: 34.986 mm (1.3774 in)

I.D.: 25.013 mm (0.9848 in)

Check the needle bearing turns smoothly and quietly.

Replace the bearing if necessary.

When the clutch outer guide or needle bearing is replaced, be sure to select the needle bearing according to the selective fit table (page 10-12).

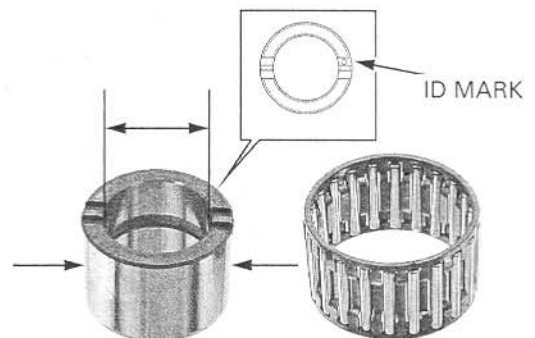

CLUTCH/STARTER CLUTCH/GEARSHIFT LINKAGE

Oil pump drive sprocket guide

Measure the O.D. and I.D. of the oil pump drive sprocket guide.

SERVICE LIMITS:

O.D.: 34.940 mm (1.3756 in)

I.D.: 25.031 mm (0.9855 in)

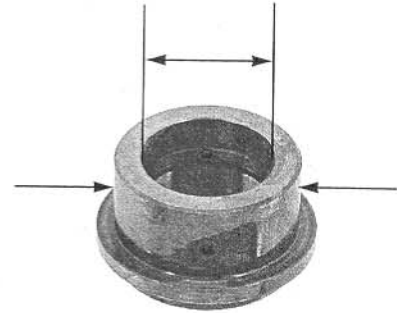

Mainshaft

Measure the mainshaft O.D. at clutch outer guide and oil pump drive sprocket guide sliding surfaces.

SERVICE LIMITS:

Oil pump drive sprocket
guide position: 24.960 mm (0.9827 in)

Clutch outer guide position: 24.960 mm (0.9827 in)

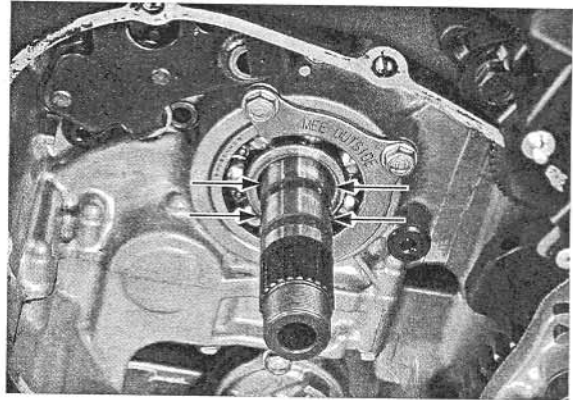

Starter idle gear/idle gear shaft

Check the starter idle gear and shaft for wear or damage, replace them if necessary.

STARTER IDLE GEAR

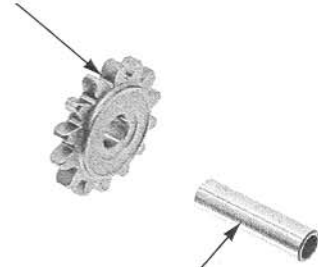

STARTER IDLE GEAR SHAFT

NEEDLE BEARING SELECTION

The primary driven gear has I.D. code letter as shown.

The clutch outer guide has O.D. code letter as shown.

Cross-reference the primary driven gear and clutch outer guide codes to determine the replacement needle bearing.

Refer to the selection table below for bearing selection.

NEEDLE BEARING



CLUTCH/STARTER CLUTCH/GEARSHIFT LINKAGE

NEEDLE BEARING SELECTION TABLE:

			CLUTCH OUTER GUIDE ID MARK	
			GUIDE A (Without ID mark)	GUIDE B (With ID mark)
			35.004 – 35.012 mm (1.3781 – 1.3784 in)	34.996 – 35.004 mm (1.3778 – 1.3781 in)
PRIMARY DRIVEN GEAR ID MARK	A	41.008 – 41.016 mm (1.6145 – 1.6148 in)	NEEDLE BEARING B	NEEDLE BEARING A
	B	41.000 – 41.008 mm (1.6142 – 1.6145 in)	NEEDLE BEARING C	NEEDLE BEARING B

INSTALLATION

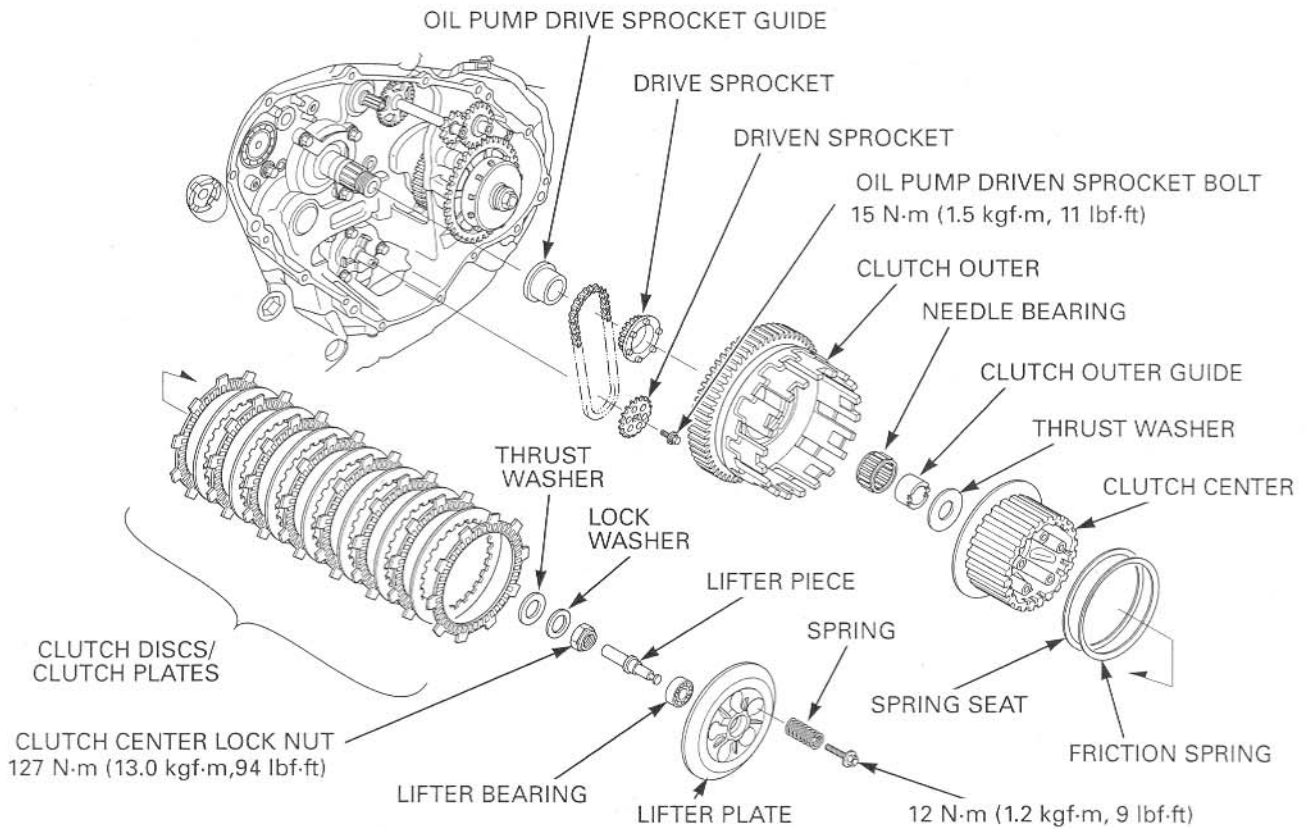

Install the oil pump drive sprocket guide.

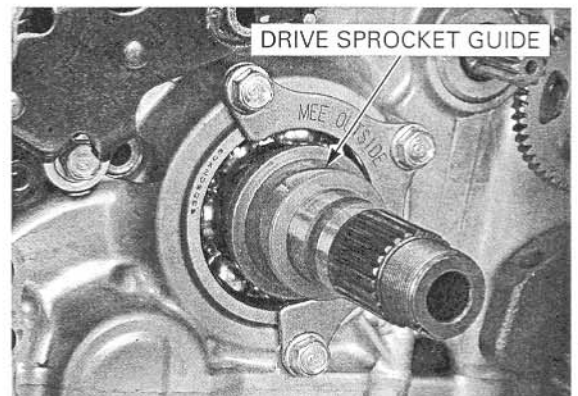

CLUTCH/STARTER CLUTCH/GEARSHIFT LINKAGE

Install the oil pump driven sprocket with its "OUT" mark facing out.

Install the oil pump drive/driven sprocket and drive chain as an assembly.

Apply a locking agent to the threads of the oil pump driven sprocket bolt.

Install the oil pump driven sprocket bolt, washer and tighten the bolt to the specified torque.

TORQUE: 15 N·m (1.5 kgf·m, 11 lbf·ft)

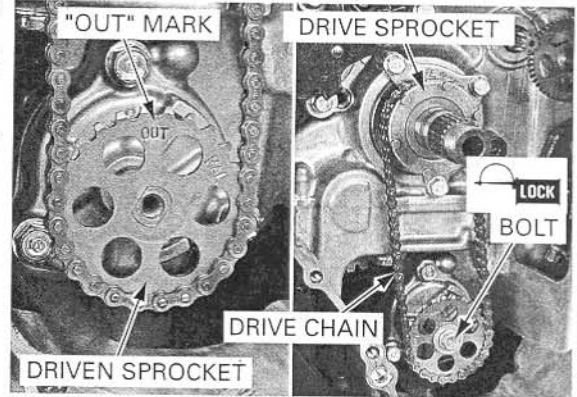

Apply molybdenum oil solution to the clutch outer sliding surface.

Install the clutch outer while aligning the tabs of the oil pump drive sprocket with holes of the clutch outer.

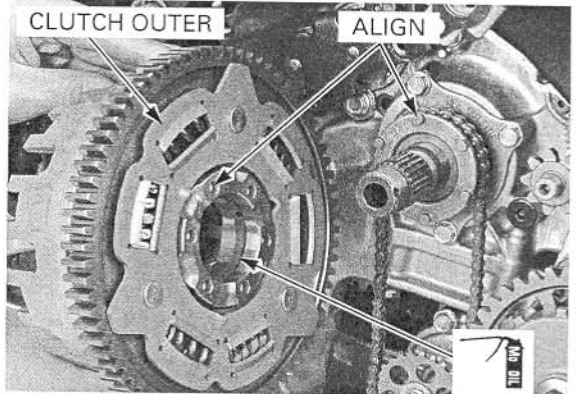

Apply molybdenum oil solution to the clutch outer guide sliding surface.

Install the clutch outer guide with its grooves facing out.

Install the clutch outer guide and needle bearing onto the mainshaft (Refer to the needle bearing selection: page 10-13).

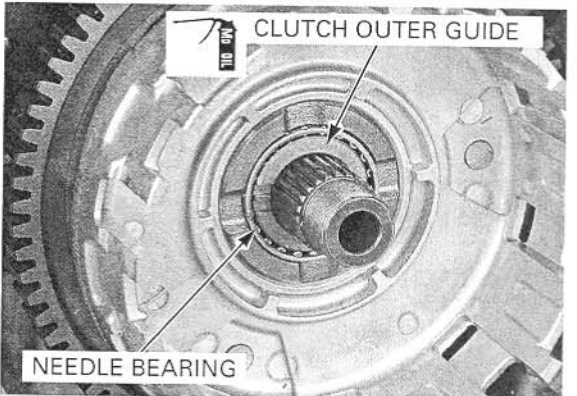

Install the thrust washer.

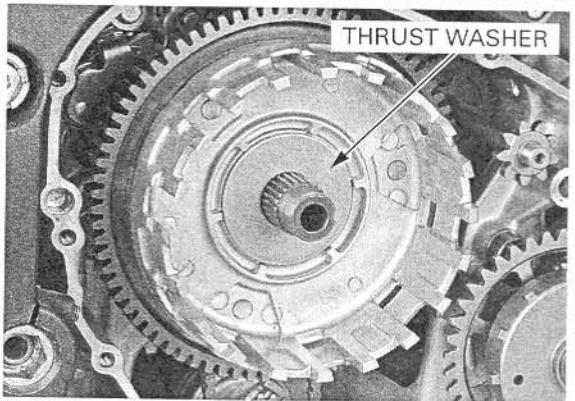

CLUTCH/STARTER CLUTCH/GEARSHIFT LINKAGE

Install the clutch center and thrust washer.

Install the lock washer with its "OUT" mark facing out.

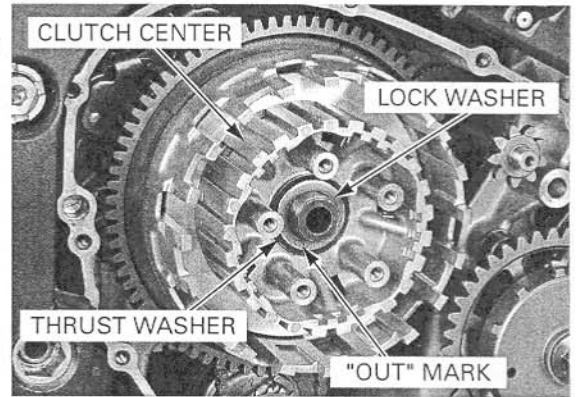

Apply oil to the threads and seating surface of a new clutch center lock nut, then install it onto the mainshaft.

Hold the clutch center with the special tool and tighten the lock nut to the specified torque.

TOOL:

Clutch center holder

07724-0050002 or equivalent commercially available in U.S.A.

TORQUE: 127 N·m (13.0 kgf·m, 94 lbf·ft)

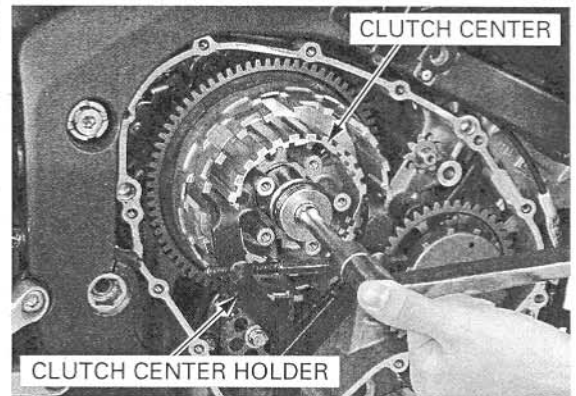

Be careful not to damage the mainshaft threads.

Stake the lock nut into the mainshaft groove with a punch.

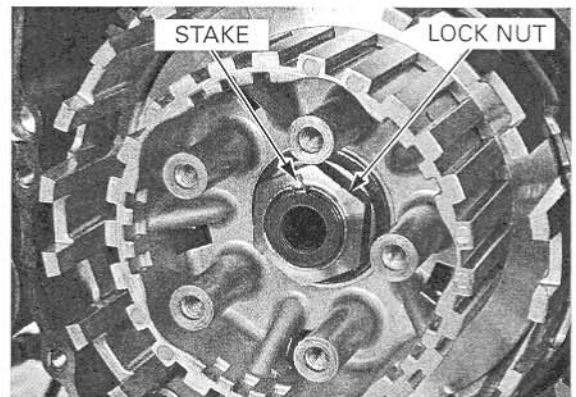

Install the spring seat and friction spring onto the clutch center as shown.

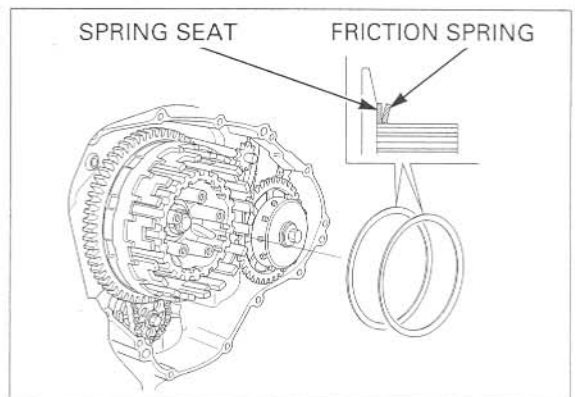

CLUTCH/STARTER CLUTCH/GEARSHIFT LINKAGE

Coat the clutch discs and plates with clean engine oil.

Install the clutch disc B (larger I.D. disc) into the clutch outer.

Stack the six clutch discs, seven plates and clutch disc A alternately.

- Clutch disc A has dark specks on the pads and green paint on the tab.
- Clutch disc B has a larger I.D. than the other discs.

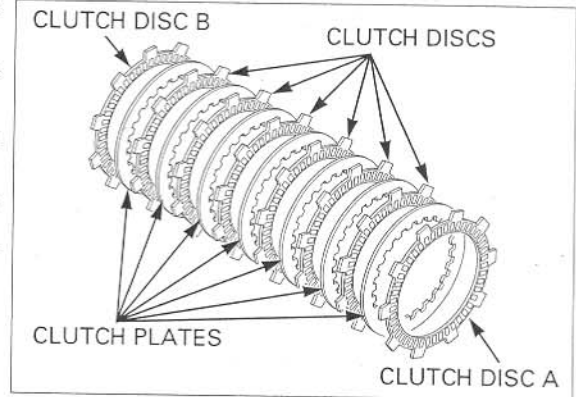

Install the tabs of outside clutch disc A into the shallow slots of the clutch outer.

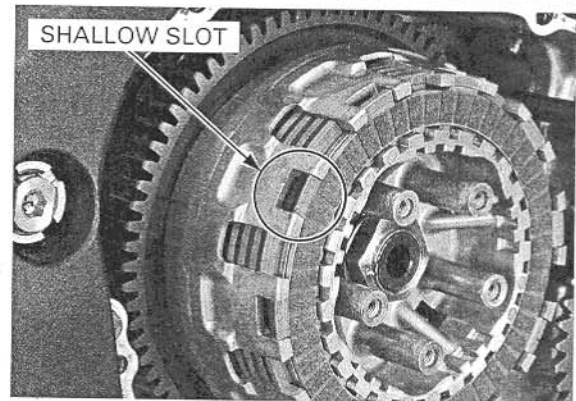

Install the lifter bearing into the pressure plate.

Install the clutch lifter piece into the lifter bearing.

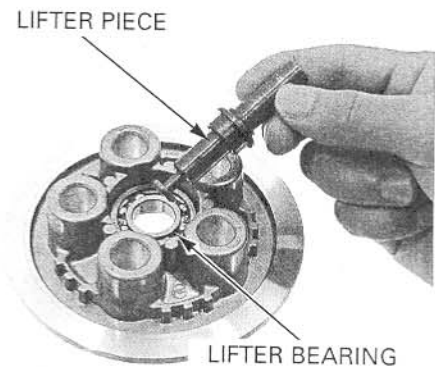

Install the pressure plate.

Install the clutch springs and spring bolts.

Tighten the bolts to the specified torque in a criss-cross pattern in two to three steps.

TORQUE: 12 N·m (1.2 kgf·m, 9 lbf·ft)

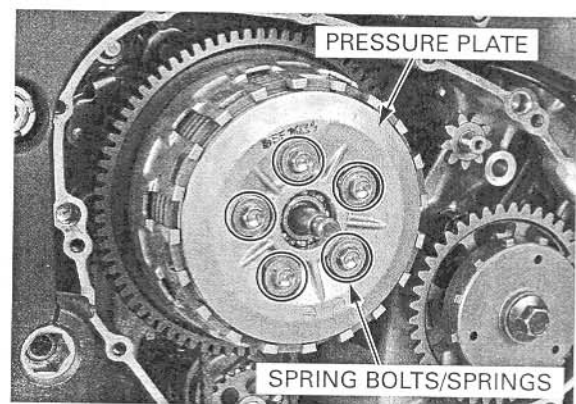

CLUTCH/STARTER CLUTCH/GEARSHIFT LINKAGE

Install the starter idle gear and shaft.

Install the right crankcase cover (page 10-24).

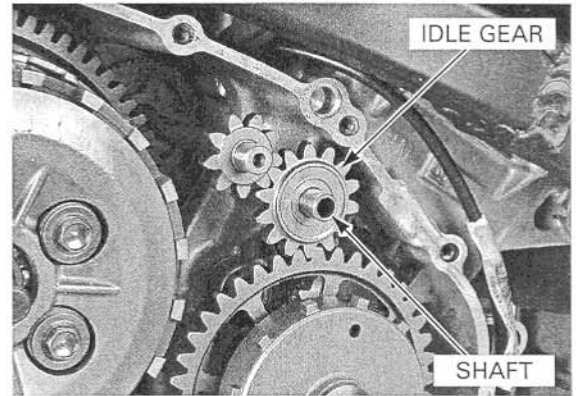

STARTER CLUTCH

REMOVAL

Remove the clutch (page 10-7).

Remove the starter reduction gear from the crankcase.

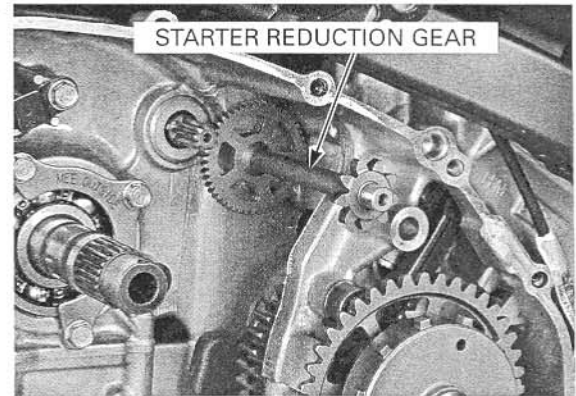

Temporarily install the following:

- Starter idle gear
- Starter idle gear shaft

Insert the gear holder between the starter idle gear and driven gear as shown.

TOOL:

Gear holder, M2.5 **07724-0010100**

Remove the starter clutch outer special bolt and washer.

Remove the temporarily installed parts.

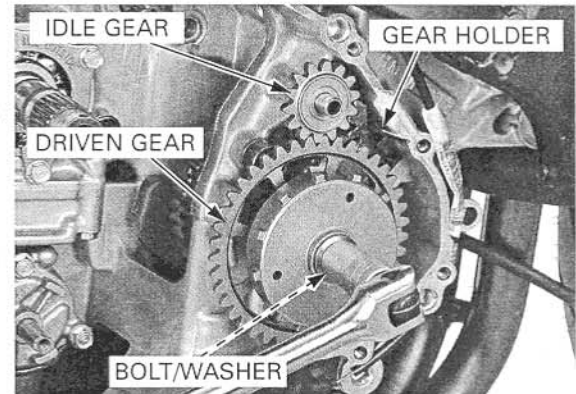

Remove the starter clutch outer assembly.

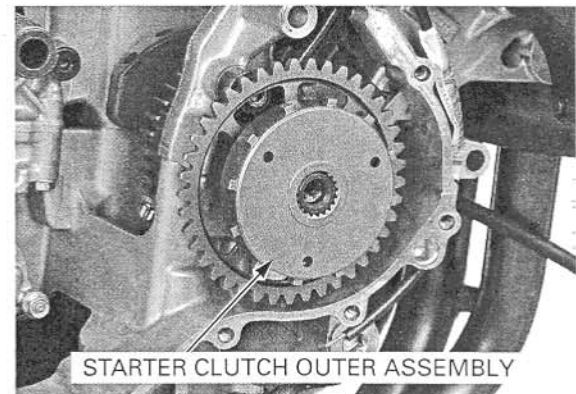

CLUTCH/STARTER CLUTCH/GEARSHIFT LINKAGE

Remove the thrust washer.

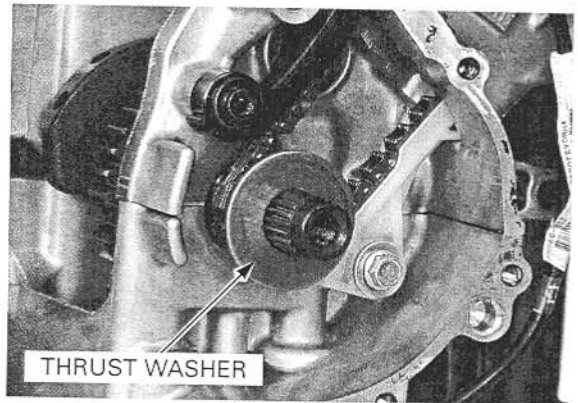

INSPECTION

Check the operation of the one-way clutch by turning the driven gear. You should be able to turn the driven gear clockwise smoothly, but the gear should not turn counterclockwise.

DISASSEMBLY

Remove the starter driven gear by turning it counterclockwise.

Remove the needle bearing.

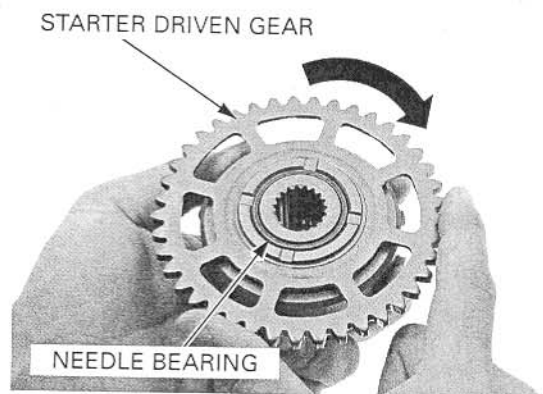

Remove the snap ring and one-way clutch.

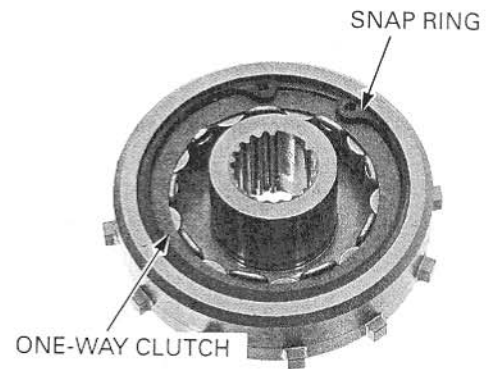

Check the starter clutch outer inner surface and one-way clutch for abnormal wear or damage and replace them if necessary.

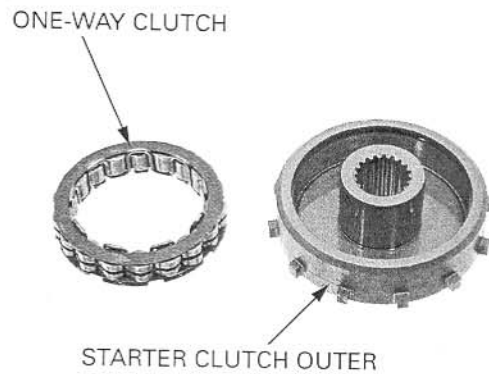

CLUTCH/STARTER CLUTCH/GEARSHIFT LINKAGE

Check the starter driven gear for abnormal wear or damage.

Measure the starter driven gear boss O.D.

SERVICE LIMIT: 45.642 mm (1.7969 in)

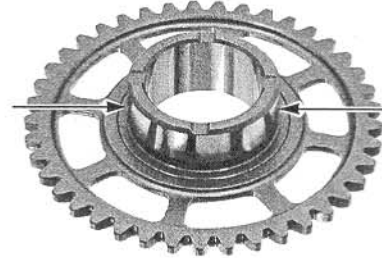

Check the starter reduction gear for wear or damage and replace it if necessary.

STARTER REDUCTION GEAR

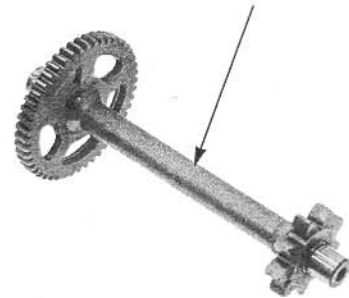

ASSEMBLY

STARTER DRIVEN GEAR

ONE-WAY CLUTCH

NEEDLE BEARING

SNAP RING

STARTER CLUTCH OUTER

74 N·m (7.5 kgf·m, 54 lbf·ft)

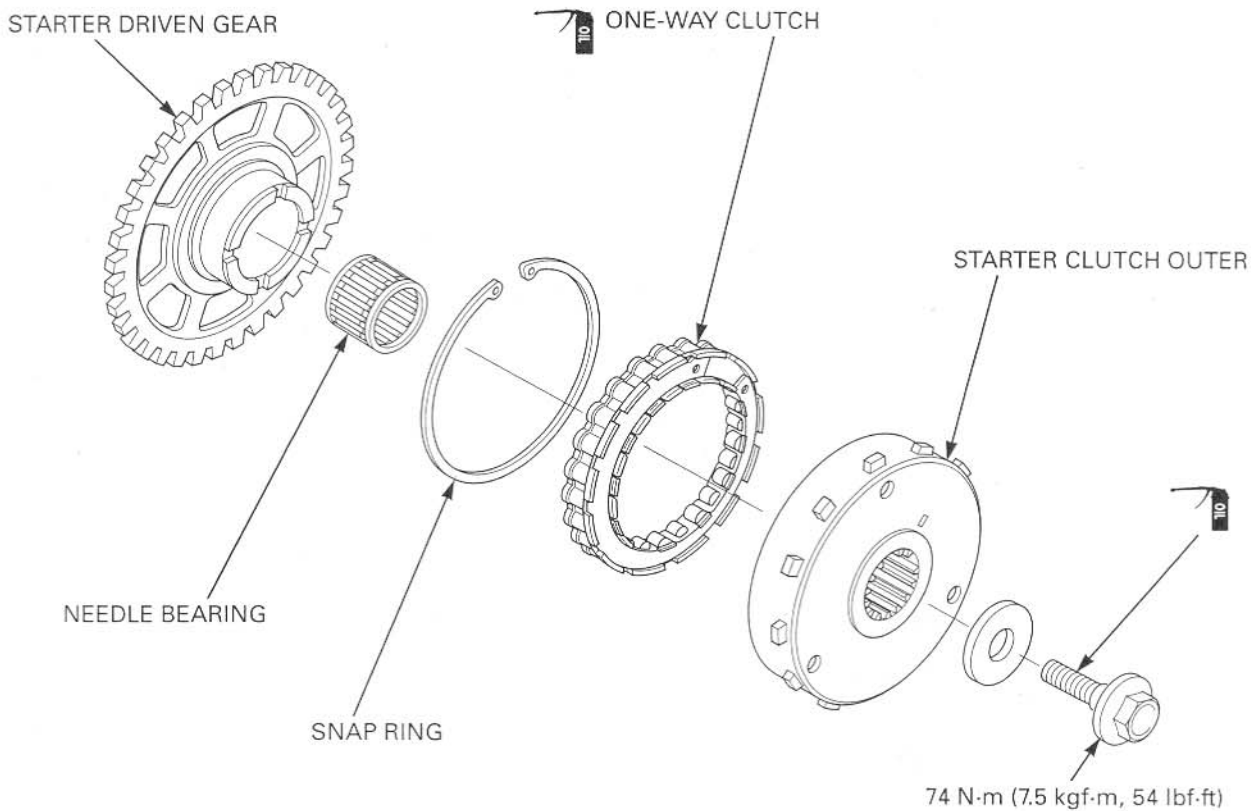

CLUTCH/STARTER CLUTCH/GEARSHIFT LINKAGE

Apply oil to the one-way clutch.
Install the one-way clutch into the starter clutch outer.

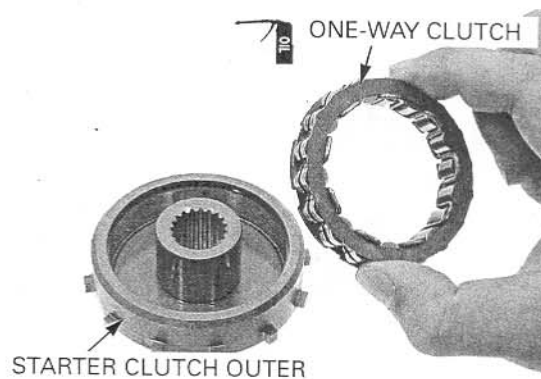

Install the snap ring into the starter clutch outer groove securely.

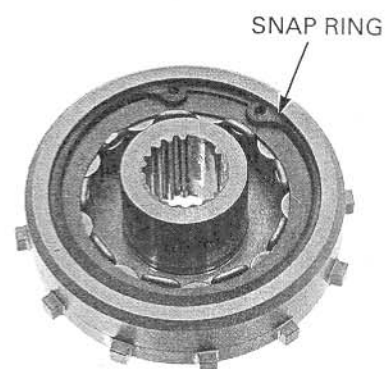

Install the starter driven gear and needle bearing into the starter clutch outer while turning the starter driven gear clockwise.

Recheck the one-way clutch operation (page 10-18).

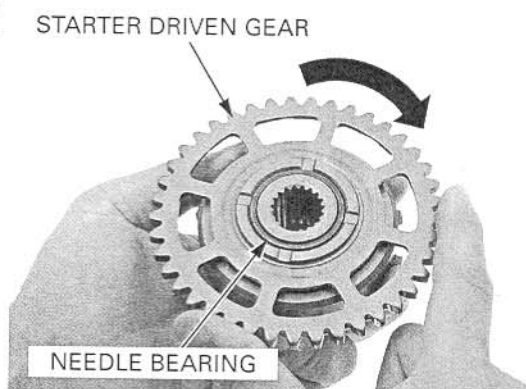

INSTALLATION

Install the thrust washer into the crankshaft.

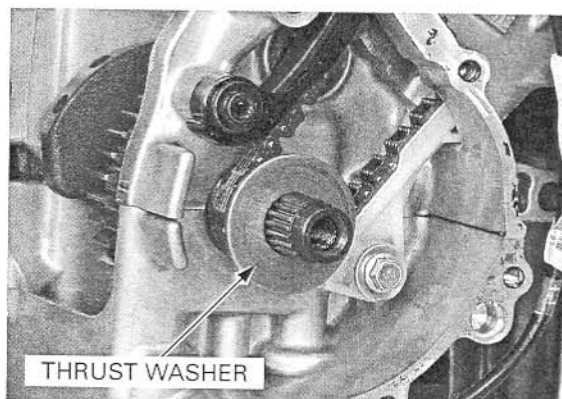

CLUTCH/STARTER CLUTCH/GEARSHIFT LINKAGE

Install the starter clutch outer assembly into the crankshaft while aligning the tab of the crankshaft with the wide groove of the starter clutch assembly.

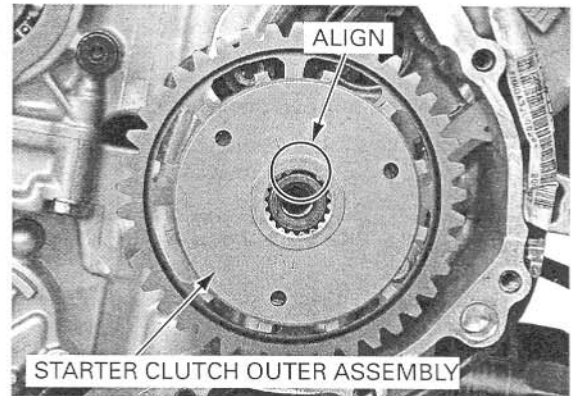

Apply oil to the starter clutch outer special bolt threads and seating surface.

Install the washer and starter clutch outer special bolt.

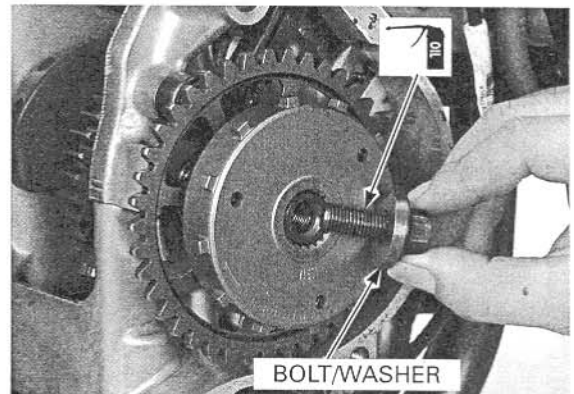

Temporarily install the following:

- Oil pump drive gear guide
- Oil pump drive gear
- Clutch outer
- Clutch outer guide
- Clutch outer needle bearing

Be careful not to drop the gear holder into the crankcase.

Attach the gear holder between the primary drive gear and driven gear.

TOOL:

Gear holder, M2.5 07724-0010100

Tighten the starter clutch special bolt to the specified torque.

TORQUE: 74 N·m (7.5 kgf·m, 54 lbf·ft)

Remove the temporarily installed parts.

Install the starter reduction gear into the crankcase.

Install the clutch (page 10-13).

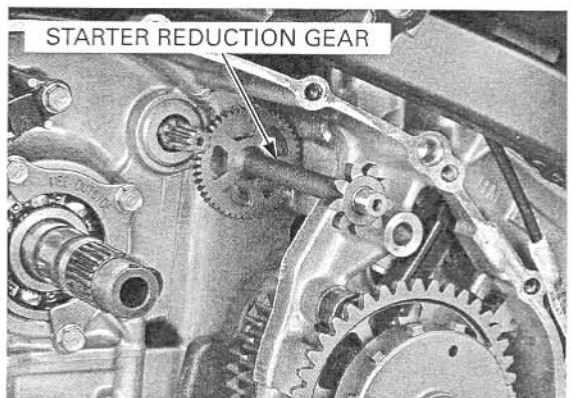
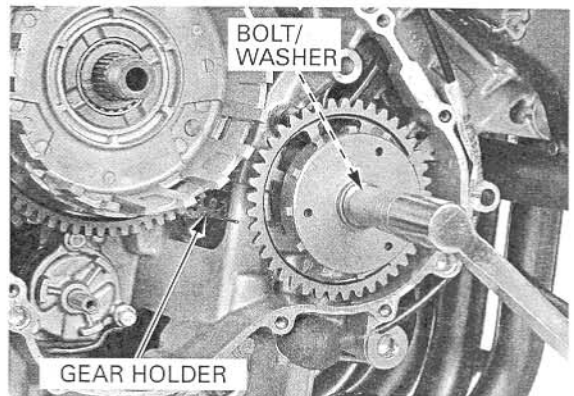

CLUTCH/STARTER CLUTCH/GEARSHIFT LINKAGE

GEARSHIFT LINKAGE

REMOVAL

Remove the following:

- Right crankcase cover (page 10-5)
- Clutch (page 10-7)

Remove the pinch bolt and disconnect the gear shift arm from the gear shift spindle.

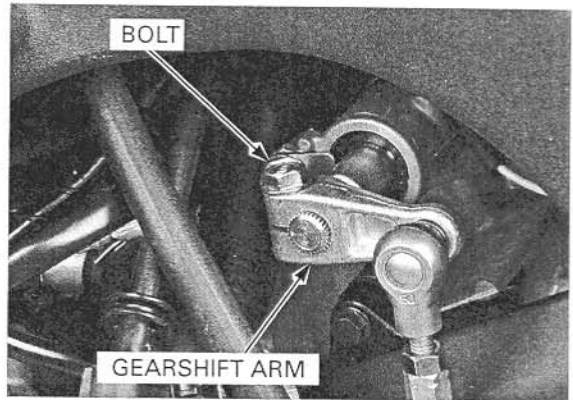

Remove the bolt and setting plate.

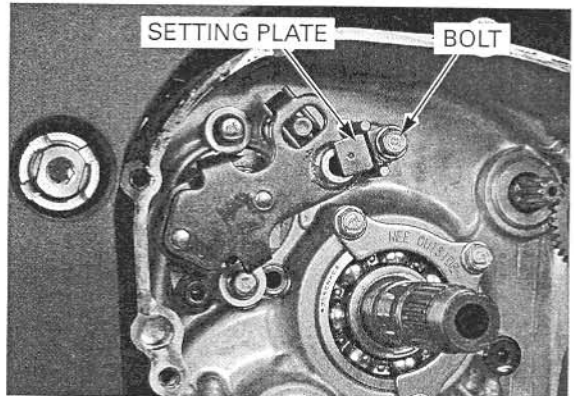

Pull the gearshift spindle assembly and thrust washer out of the crankcase.

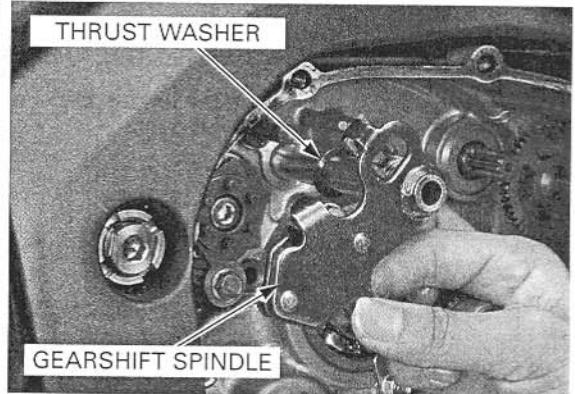

Remove the following:

- Stopper arm pivot bolt
- Stopper arm
- Return spring
- Washer
- Shift drum center socket bolt
- Gearshift cam
- Dowel pin

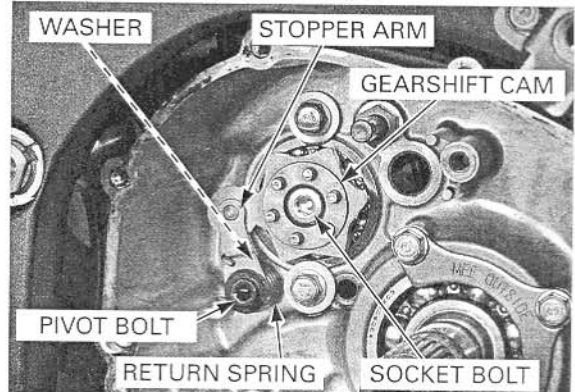

CLUTCH/STARTER CLUTCH/GEARSHIFT LINKAGE

INSPECTION

Check the gearshift spindle for wear, damage or bending.

Check the return spring for fatigue or damage.

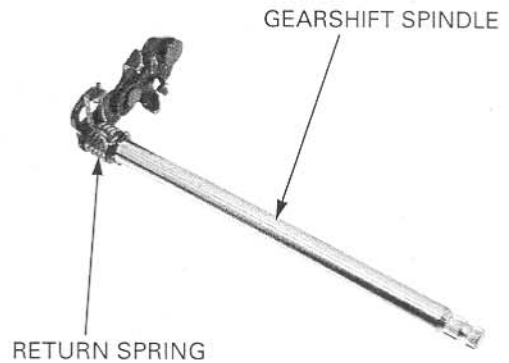

INSTALLATION

Install the following:

- Washer
- Return spring
- Stopper arm
- Pivot bolt

Tighten the stopper arm pivot bolt to the specified torque.

TORQUE: 12 N·m (1.2 kgf·m, 9 lbf·ft)

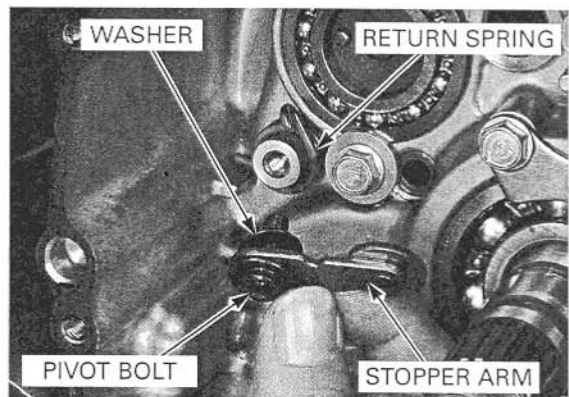

Install the dowel pin onto the shift drum.

Align the dowel pin on the shift drum with the wide groove on the gearshift cam.

Install the gearshift cam while holding the stopper arm using a screwdriver as shown.

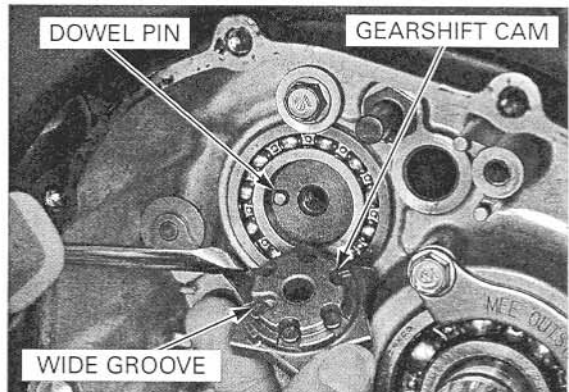

Apply a locking agent to the shift drum center socket bolt threads.

Tighten the socket bolt to the specified torque.

TORQUE: 23 N·m (2.3 kgf·m, 17 lbf·ft)

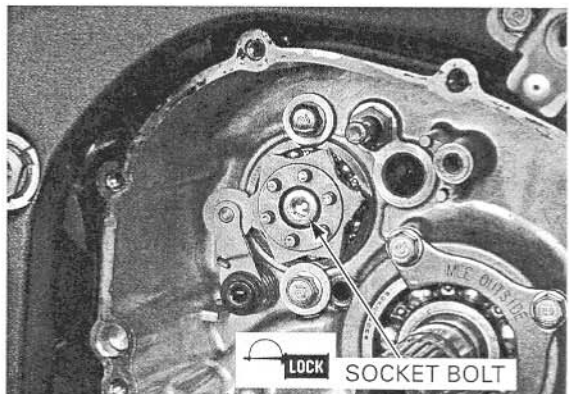

CLUTCH/STARTER CLUTCH/GEARSHIFT LINKAGE

Install the thrust washer and gearshift spindle assembly into the crankcase while aligning the spring ends with the crankcase stopper pin.

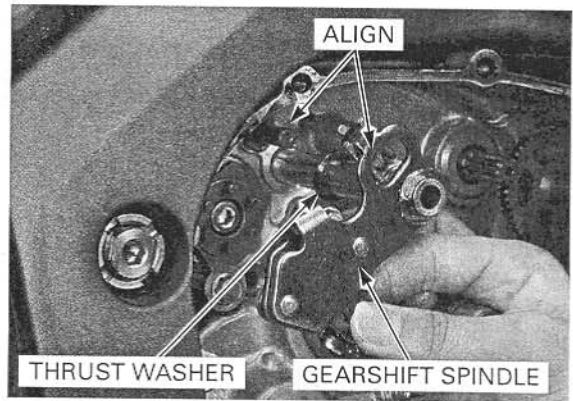

Apply a locking agent to the thread, install the setting plate and bolt. Tighten the bolt.

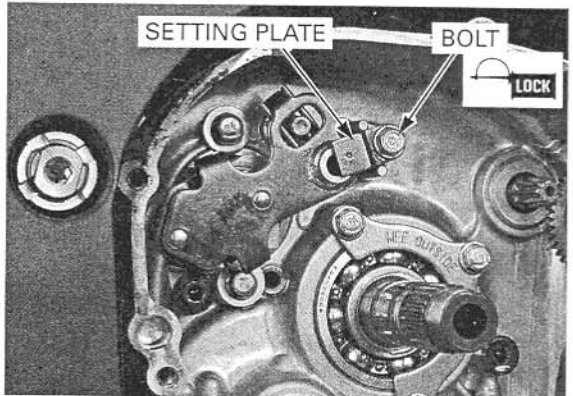

Install the gearshift arm to the gearshift spindle, aligning the arm slit with the punch mark on the gearshift spindle. Install and tighten the pinch bolt.

Install the clutch (page 10-13).

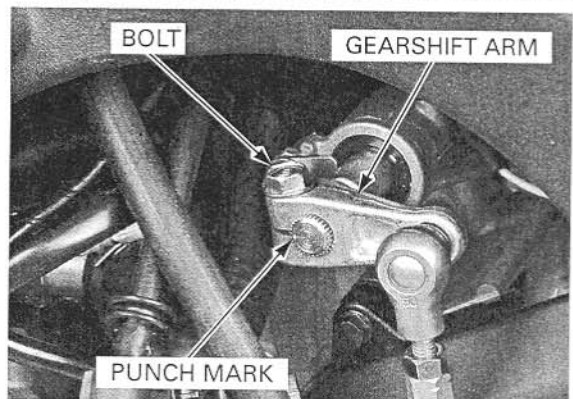

RIGHT CRANKCASE COVER INSTALLATION

Apply sealant to the mating surface of the right crankcase cover.

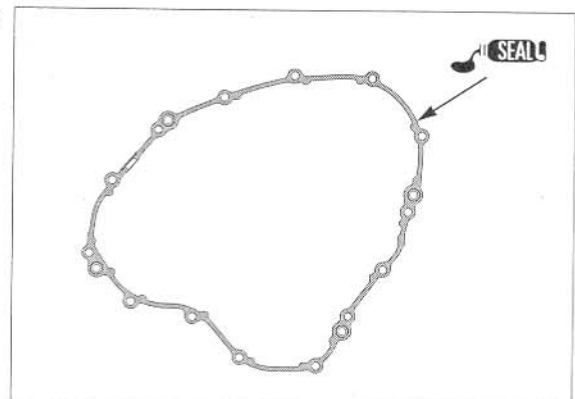

CLUTCH/STARTER CLUTCH/GEARSHIFT LINKAGE

Install the four dowel pins.

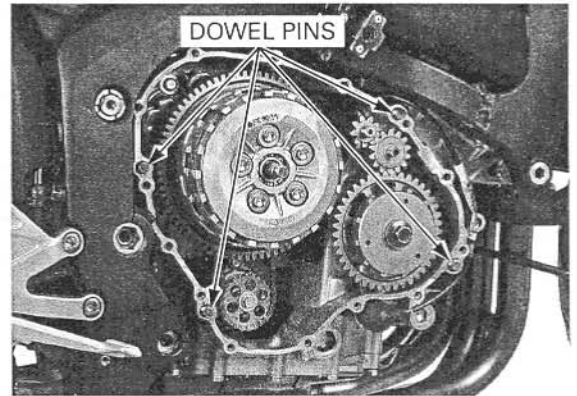

Install the wave washer and thrust washer onto the starter idle gear.

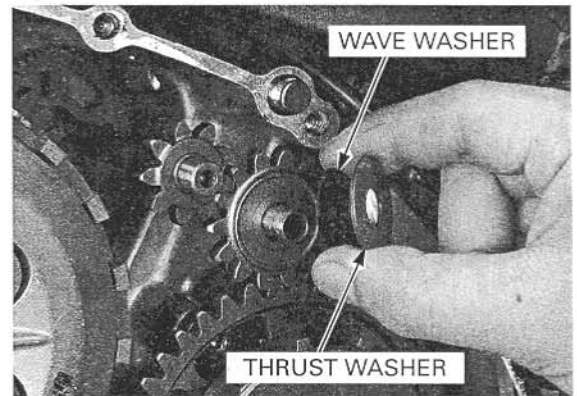

Install the right crankcase cover while turning the lifter lever clockwise to engage the lifter lever spindle groove with the lifter piece flange.

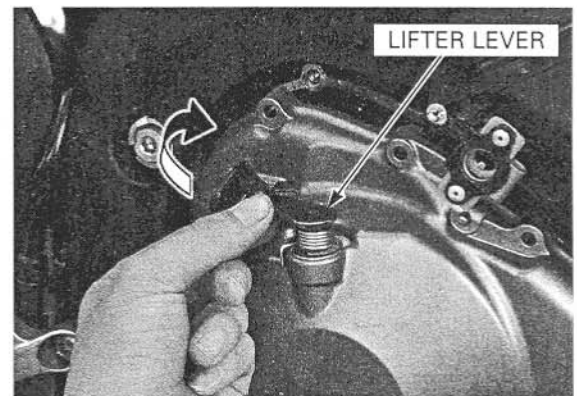

Install the radiator reserve tank stay and right crankcase cover bolts.

Tighten the right crankcase cover bolts crisscross pattern in two to three steps.

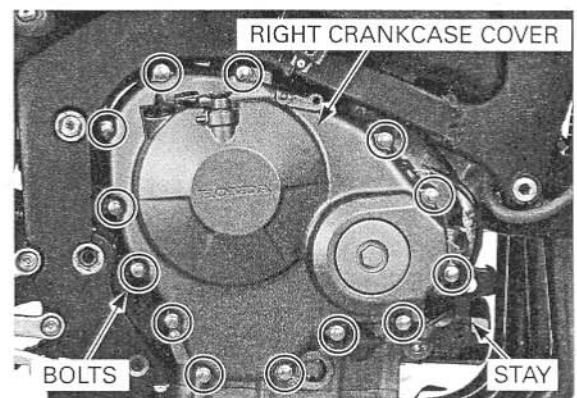

CLUTCH/STARTER CLUTCH/GEARSHIFT LINKAGE

Connect the clutch cable end to the clutch lifter lever, then install the clutch cable guide plate with the bolt.

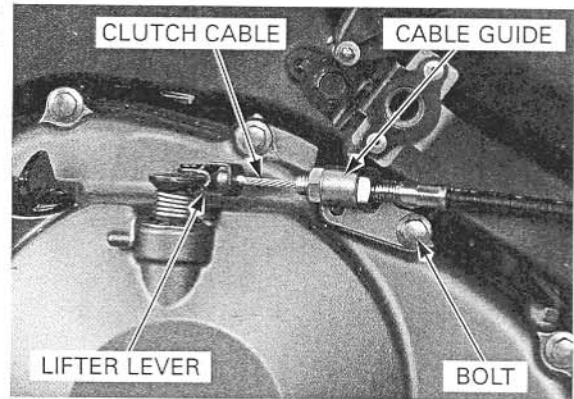

Connect the ignition pulse generator 2P (Red) connector.

Add the recommended engine oil (page 4-16).

Install the following:

- Radiator reserve tank (page 7-18)
- Middle cowls (page 3-8)
- Lower cowls (page 3-6)

Adjust the clutch lever free play (page 4-28).

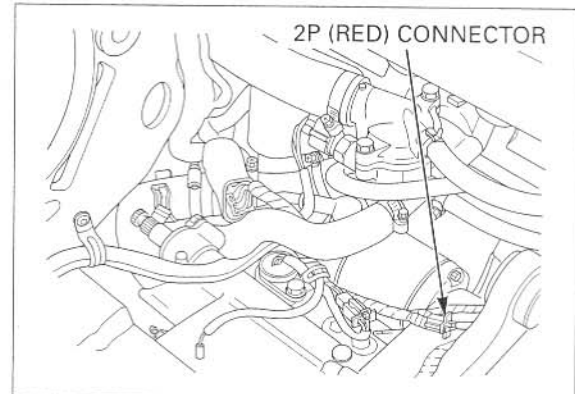

11. ALTERNATOR

COMPONENT LOCATION	11-2	STATOR	11-4
SERVICE INFORMATION	11-3	FLYWHEEL	11-5
ALTERNATOR COVER REMOVAL.....	11-4	ALTERNATOR COVER INSTALLATION	11-7

ALTERNATOR

COMPONENT LOCATION

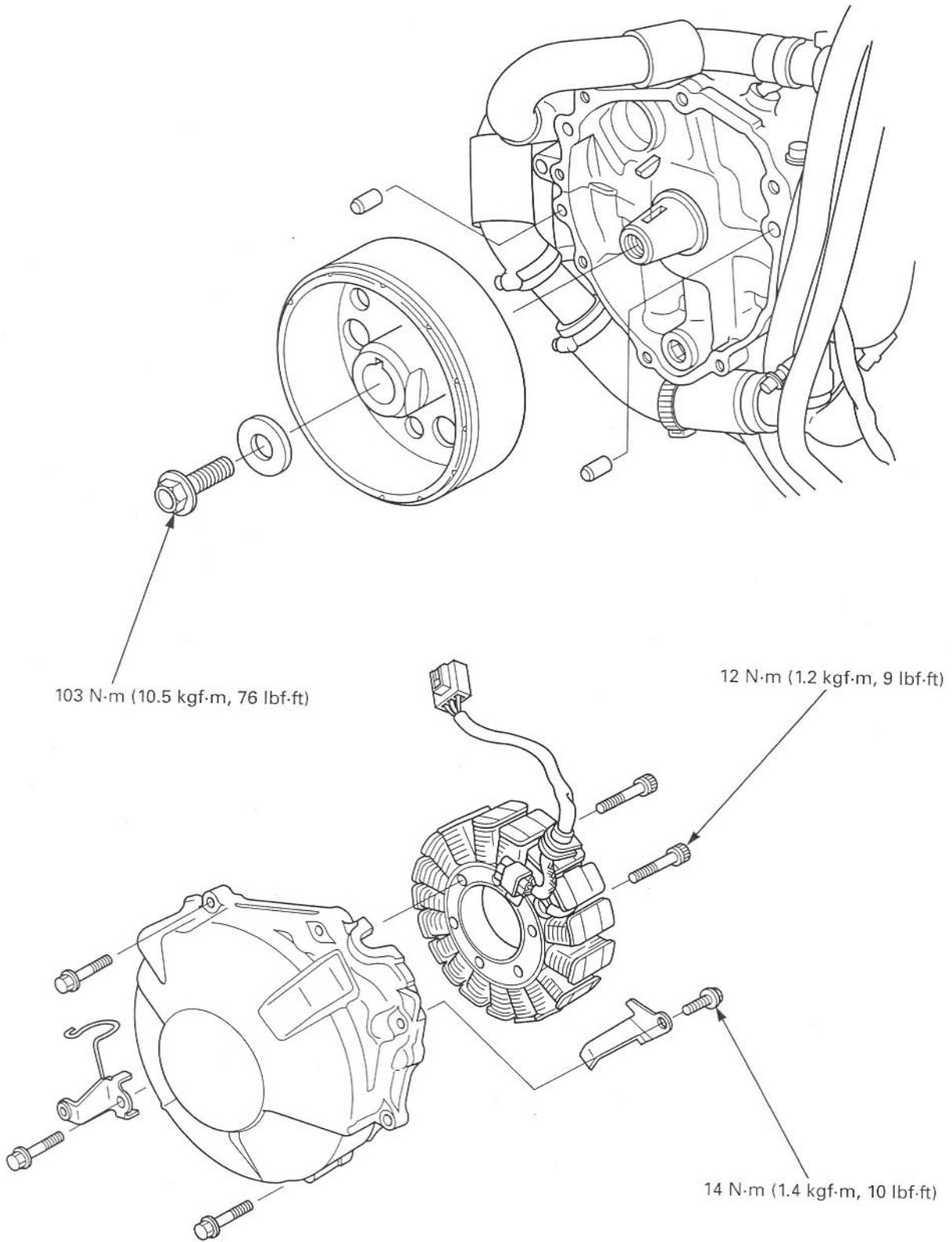

SERVICE INFORMATION

GENERAL

- This section covers service of the alternator stator and flywheel. All service can be done with the engine installed in the frame.
- Refer to procedures for alternator stator inspection (page 17-9).
- Refer to procedures for starter motor servicing (page 19-6).

TORQUE VALUES

Alternator stator socket bolt	12 N·m (1.2 kgf·m, 9 lbf·ft)	
Flywheel bolt	103 N·m (10.5 kgf·m, 76 lbf·ft)	Apply oil to the threads
Stator wire clamp bolt	14 N·m (1.4 kgf·m, 10 lbf·ft)	CT bolt

TOOLS

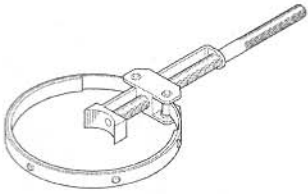
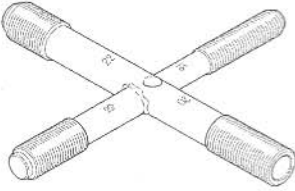
<p>Flywheel holder 07725-0040000</p>  <p>or equivalent commercially available in U.S.A.</p>	<p>Rotor puller 07733-0020001</p>  <p>or 07933-3950000 (U.S.A. only)</p>
---	--

ALTERNATOR

ALTERNATOR COVER REMOVAL

Remove the following:

- Lower cowls (page 3-6)
- Middle cowls (page 3-7)

Disconnect the alternator 3P (Natural) connector.

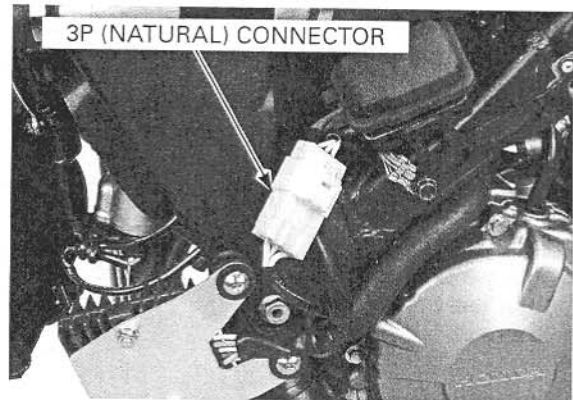

The alternator cover (stator) is magnetically attached to the flywheel, be careful during removal.

Remove the alternator cover SH bolts and alternator cover.

- Engine oil will run out when the alternator cover is removed. Set a clean oil pan under the engine and add the recommended oil to the specified level after installation.

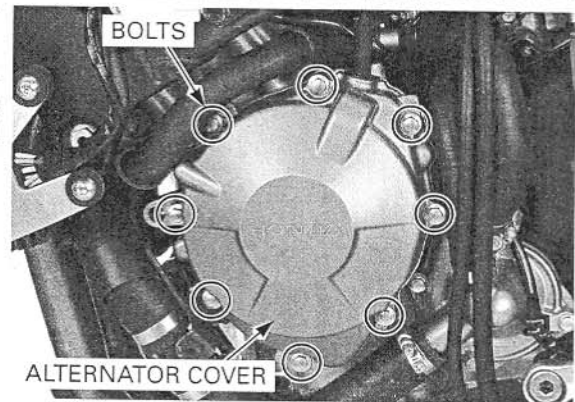

Remove the dowel pins.

Clean off any sealant from the alternator cover mating surfaces.

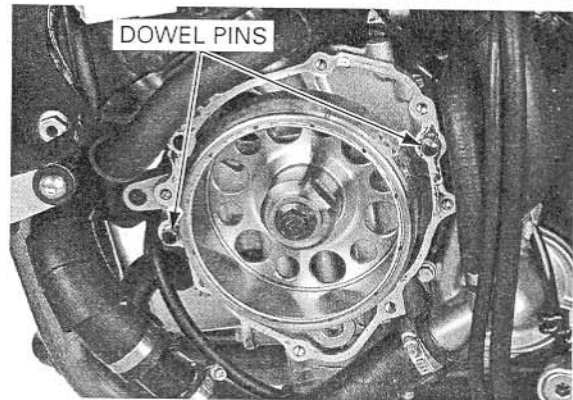

STATOR

REMOVAL

Remove the alternator cover (page 11-4).

Remove the bolt and stator wire clamp.
Remove the alternator wire grommet from the alternator cover.

Remove the socket bolts and stator.

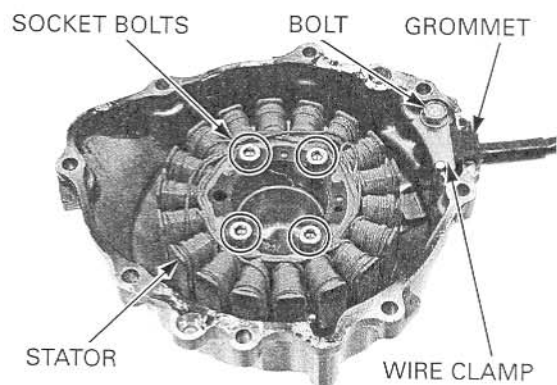

INSTALLATION

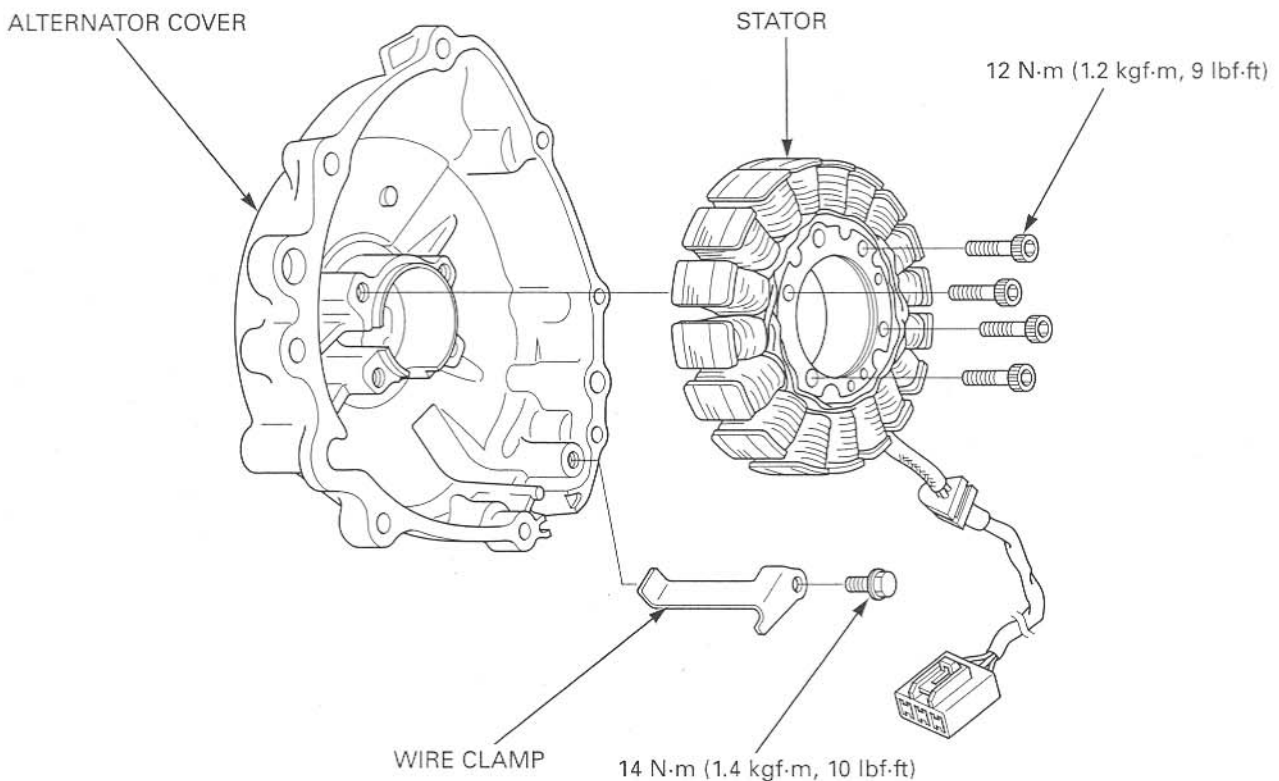

Install the stator into the alternator cover.
 Apply sealant to the wire grommet, then install the wire grommet into the alternator cover groove securely.
 Install and tighten the socket bolts to the specified torque.

TORQUE: 12 N·m (1.2 kgf·m, 9 lbf·ft)

Install the wire clamp and tighten the flange bolt to the specified torque.

TORQUE: 14 N·m (1.4 kgf·m, 10 lbf·ft)

Install the alternator cover (page 11-7).

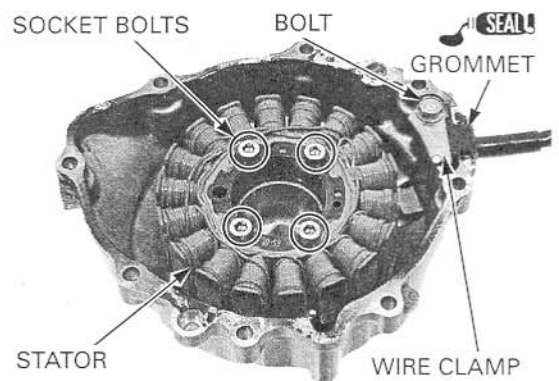

FLYWHEEL

REMOVAL

Remove the alternator cover (page 11-4).

Hold the flywheel using the special tool, then remove the flywheel bolt.

TOOL:

Flywheel holder

07725-0040000 or equivalent commercially available in U.S.A.

Remove the washer.

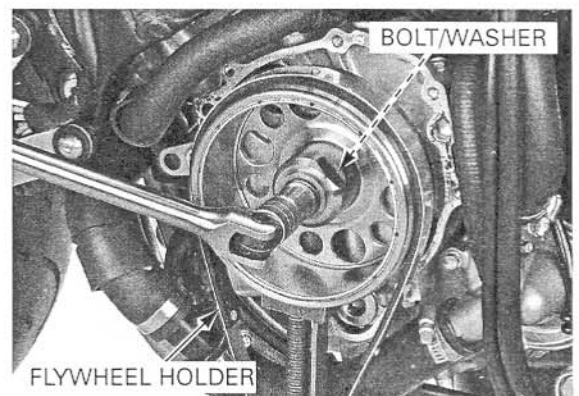

ALTERNATOR

Remove the flywheel using the special tool.

TOOL:
Rotor puller

07733-0020001 or
07933-3950000
(U.S.A. only)

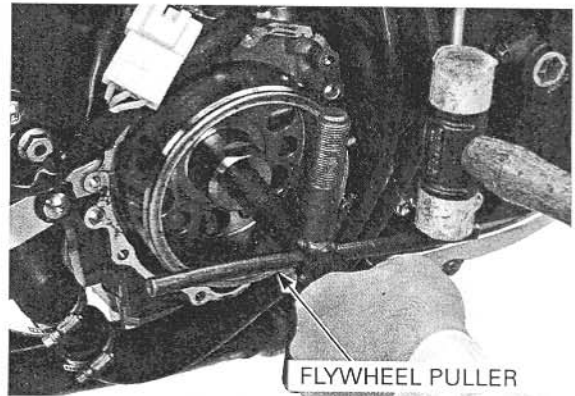

Remove the woodruff key from the crankshaft.

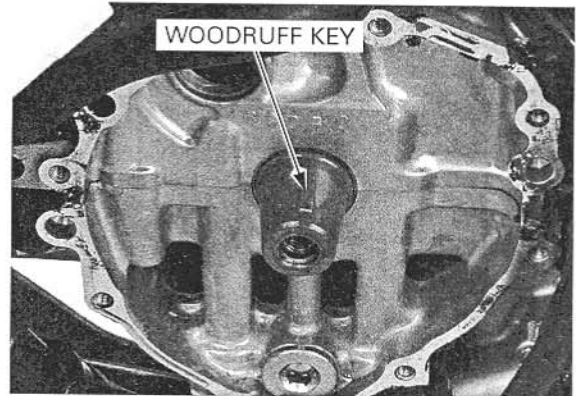

INSTALLATION

Clean any oil from the crankshaft taper.
Install the woodruff key into the groove of the crankshaft.

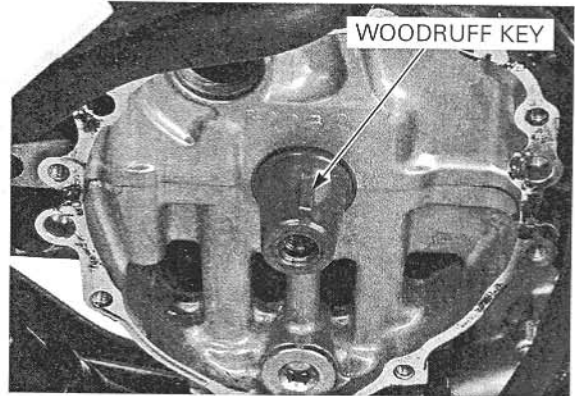

Install the flywheel aligning the key way in the flywheel with the woodruff key on the crankshaft.

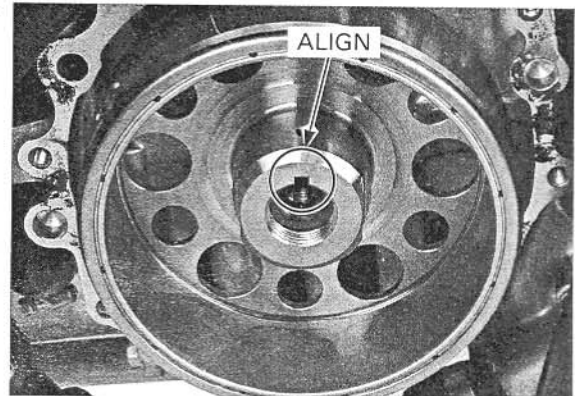

Apply oil to the flywheel bolt threads and seating surface.
Install the washer and flywheel bolt.

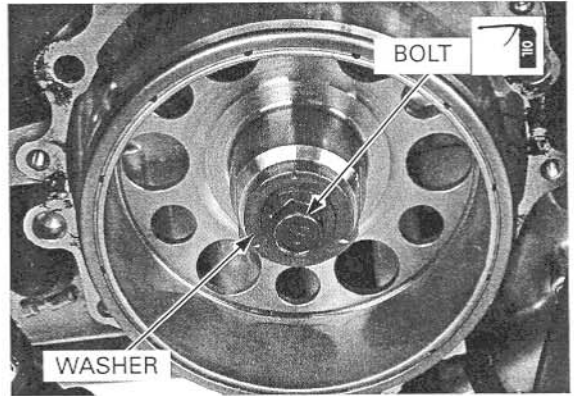

Hold the flywheel using the special tool, then tighten the bolt to the specified torque.

TOOL:
Flywheel holder

07725-0040000 or
equivalent commercially available in
U.S.A.

TORQUE: 103 N-m (10.5 kgf-m, 76 lbf-ft)

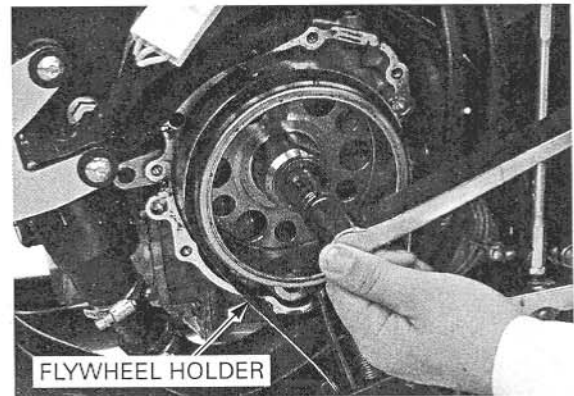

ALTERNATOR COVER INSTALLATION

Apply a sealant to the mating surface of the alternator cover.

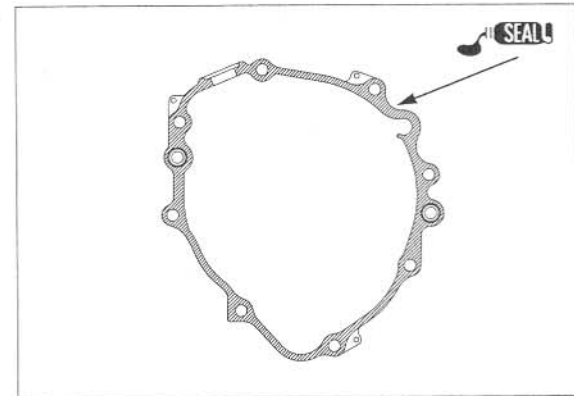

Install the dowel pins.

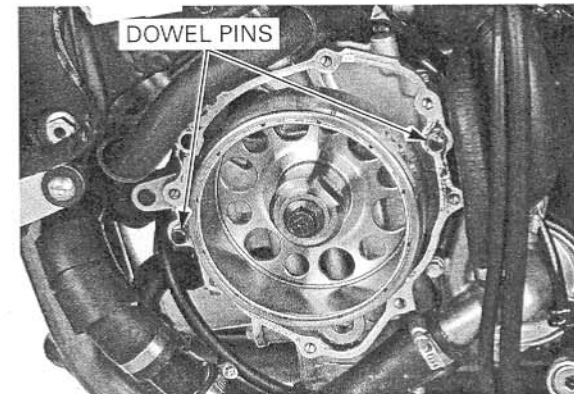

ALTERNATOR

The alternator cover (stator) is magnetically attached to the flywheel, be careful during installation.

Install the alternator cover.

Install and tighten the SH bolts securely.

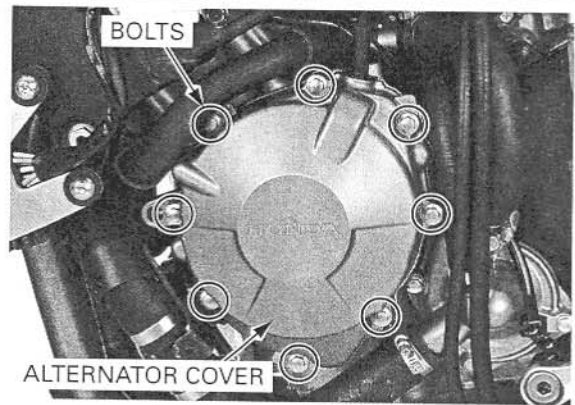

Connect the alternator 3P (Natural) connector.

Install the following:

- Middle cowls (page 3-8)
- Lower cowls (page 3-6)

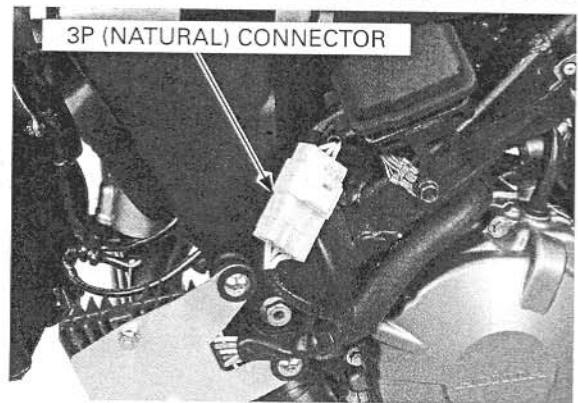

12. CRANKCASE/TRANSMISSION

COMPONENT LOCATION	12-2	CRANKCASE SEPARATION.....	12-5
SERVICE INFORMATION	12-3	SHIFT FORK/SHIFT DRUM/ TRANSMISSION	12-7
TROUBLESHOOTING	12-4	CRANKCASE ASSEMBLY	12-16

CRANKCASE/TRANSMISSION

COMPONENT LOCATION

15 N·m (1.5 kgf·m, 10 lbf·ft)+ 120°

39 N·m (4.0 kgf·m, 29 lbf·ft)

25 N·m (2.5 kgf·m, 18 lbf·ft)

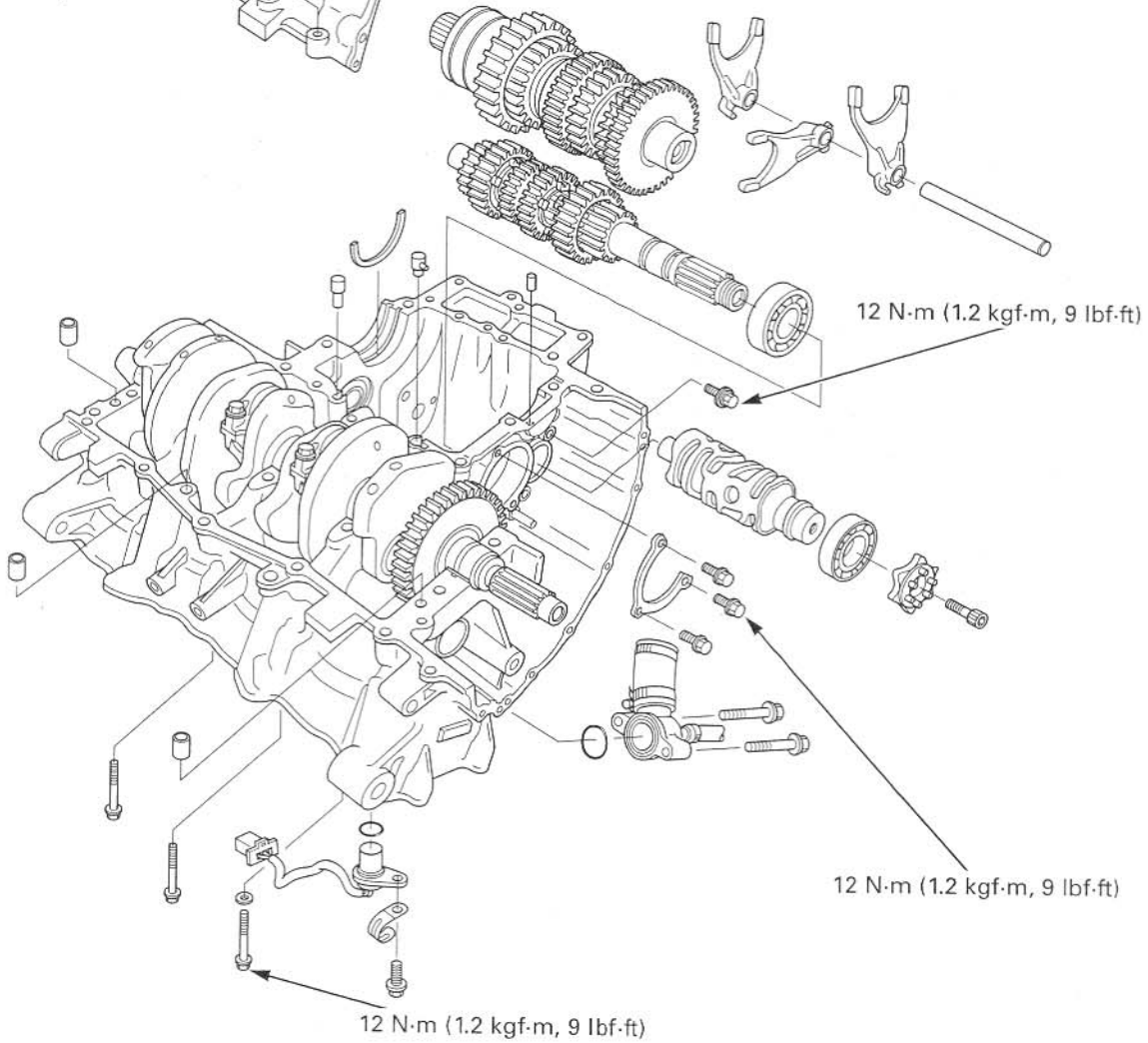
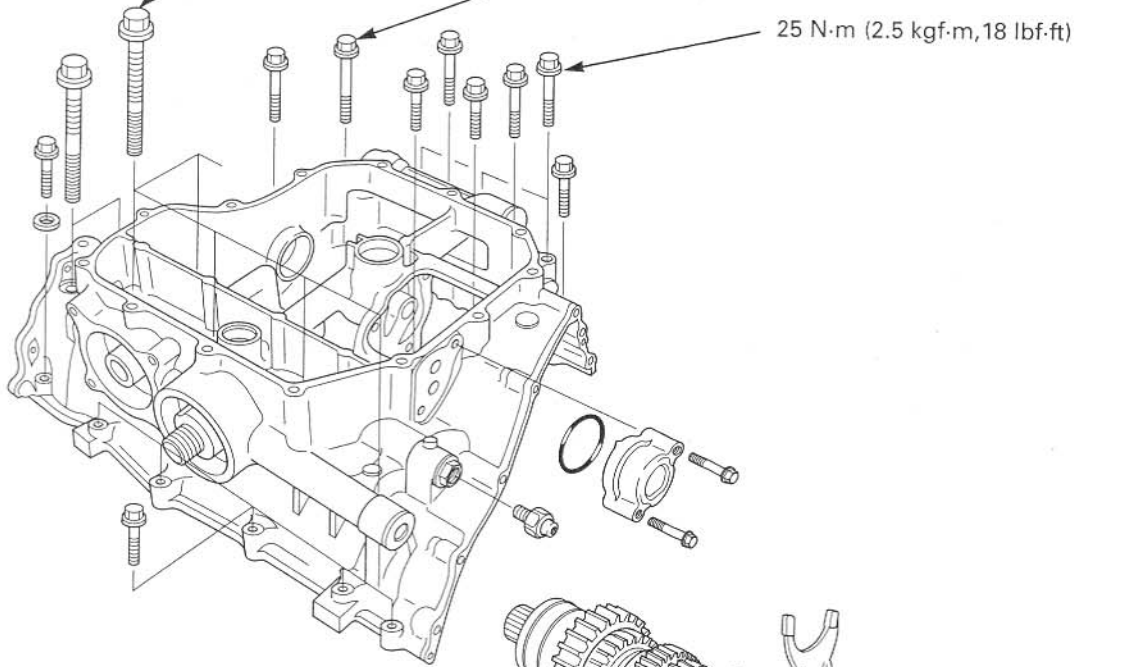

SERVICE INFORMATION

GENERAL

- The crankcase must be separated to service the following:
 - Transmission
 - Crankshaft (page 13-5)
 - Piston/connecting rod/cylinder (page 13-13)
- The following components must be removed before separating the crankcase:
 - Engine (page 8-5)
 - Clutch (page 10-7)/gearshift linkage (page 10-22)
 - Starter clutch (page 10-17)
 - Flywheel (page 11-5)
 - Cylinder head (page 9-13)
 - Oil pan (page 5-6), oil pump (page 5-8) and oil cooler (page 5-12)
 - Starter motor (page 19-6)
 - Water pump (page 7-15)
- Be careful not to damage the crankcase mating surfaces when servicing.
- Prior to assembling the crankcase halves, apply sealant to their mating surfaces. Wipe off excess sealant thoroughly.

SPECIFICATIONS

Unit: mm (in)



ITEM		STANDARD	SERVICE LIMIT
Shift fork	I.D.	12.000 – 12.018 (0.4724 – 0.4731)	12.03 (0.474)
	Claw thickness	5.93 – 6.00 (0.233 – 0.236)	5.9 (0.23)
Shift fork shaft O.D.		11.957 – 11.968 (0.4707 – 0.4712)	11.95 (0.470)
Transmission	Gear I.D.	M5, M6	28.000 – 28.021 (1.1024 – 1.1032)
		C1	24.000 – 24.021 (0.9449 – 0.9457)
		C2, C3, C4	31.000 – 31.025 (1.2205 – 1.2215)
	Gear busing O.D.	M5, M6	27.959 – 27.980 (1.1007 – 1.1016)
		C2	30.955 – 30.980 (1.2187 – 1.2197)
		C3, C4	30.950 – 30.975 (1.2185 – 1.2195)
	Gear-to-bushing clearance	M5, M6	0.020 – 0.062 (0.0008 – 0.0024)
		C2	0.020 – 0.070 (0.0008 – 0.0028)
		C3, C4	0.025 – 0.075 (0.0010 – 0.0030)
	Gear bushing I.D.	M5	24.985 – 25.006 (0.9837 – 0.9845)
		C2	27.985 – 28.006 (1.1018 – 1.1026)
	Mainshaft O.D.	at M5	24.967 – 24.980 (0.9830 – 0.9835)
	Countershaft O.D.	at C2	27.967 – 27.980 (1.1011 – 1.1016)
	Bushing to shaft clearance	M5	0.005 – 0.039 (0.0002 – 0.0015)
C2		0.005 – 0.039 (0.0002 – 0.0015)	

TORQUE VALUES

Mainshaft bearing set plate bolt	12 N·m (1.2 kgf·m, 9 lbf·ft)	Apply a locking agent to the threads
Gearshift drum bearing set bolt	12 N·m (1.2 kgf·m, 9 lbf·ft)	
Lower crankcase sealing bolt	28 N·m (2.8 kgf·m, 20 lbf·ft)	See page 12-16: replace with a new one
Crankcase 6 mm bolt	12 N·m (1.2 kgf·m, 9 lbf·ft)	
8 mm bolt	25 N·m (2.5 kgf·m, 18 lbf·ft)	
8 mm bolt (main journal bolt)	15 N·m (1.5 kgf·m, 10 lbf·ft) + 120°	
10 mm bolt	39 N·m (4.0 kgf·m, 29 lbf·ft)	
Neutral switch	12 N·m (1.2 kgf·m, 9 lbf·ft)	

CRANKCASE/TRANSMISSION

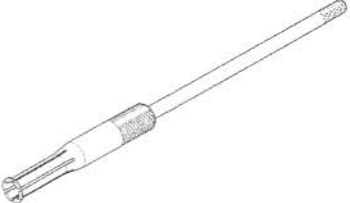
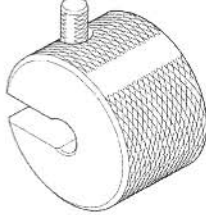
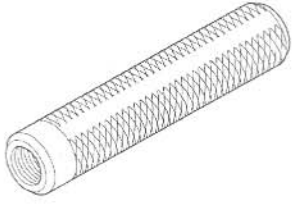
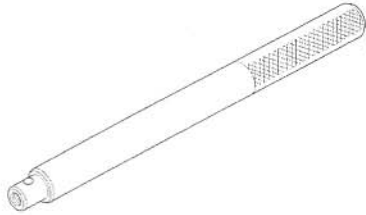
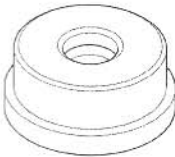
TOOLS

<p>Bearing remover set, 20 mm 07936-3710600</p> 	<p>Remover weight 07741-0010201</p>  <p>or 07936-371020A (U.S.A. only)</p>	<p>Remover handle 07936-3710100</p> 
<p>Driver 07949-3710001</p> 	<p>Attachment, 42 x 47 mm 07746-0010300</p> 	<p>Pilot, 20 mm 07746-0040500</p> 

TROUBLESHOOTING

Hard to shift

- Improper clutch operation
- Incorrect engine oil weight
- Bent shift fork
- Bent shift fork shaft
- Bent shift fork claw
- Damaged shift drum cam groove
- Bent gearshift spindle

Transmission jumps out of gear

- Worn gear dogs
- Worn gear shifter groove
- Bent shift fork shaft
- Broken shift drum stopper arm (page 10-23)
- Broken shift drum stopper arm spring (page 10-23)
- Worn or bent shift forks
- Broken gearshift spindle return spring (page 10-23)

Excessive engine noise

- Worn or damaged transmission gear
- Worn or damaged transmission bearings

CRANKCASE SEPARATION

Refer to Service Information See page 12-3 for removal of necessary parts before separating the crankcase.

Remove the bolts, water hose joint and O-ring.

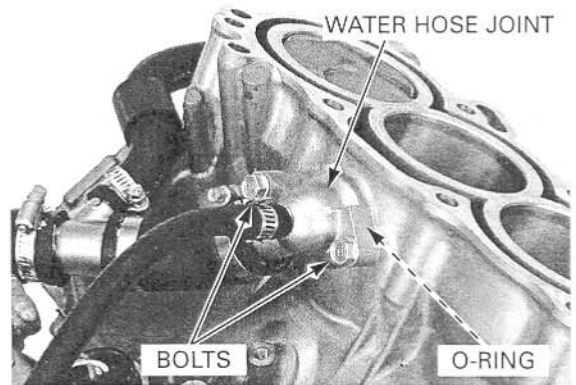

Remove the vehicle speed sensor before separating the crankcase. Do not separate or assemble the crankcase with the vehicle speed sensor installed.

Remove the bolt, clamp and vehicle speed sensor from the crankcase.

Remove the neutral switch and sealing washer from the crankcase.

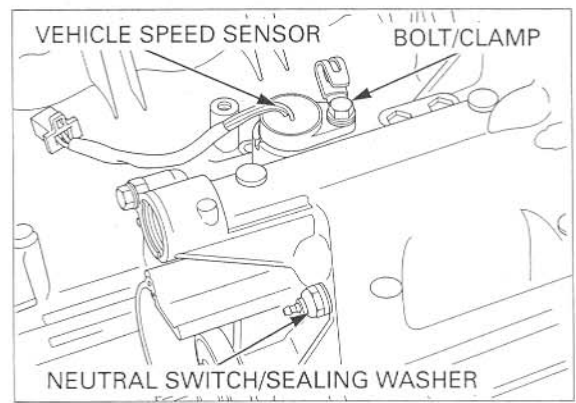

Remove the oil pressure switch while holding the switch base.

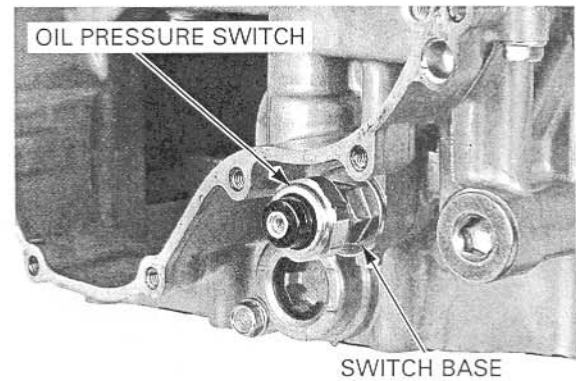

Remove the bolts, oil inspection window and O-ring from the crankcase.

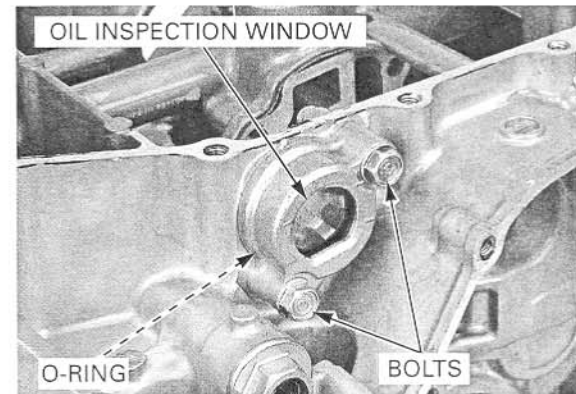

CRANKCASE/TRANSMISSION

Loosen the three bolts in two to three steps.
Remove the bolts and sealing washer.

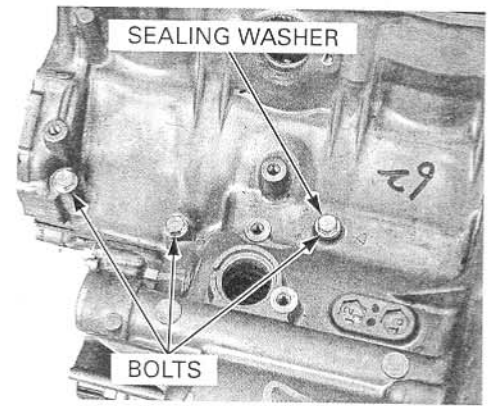

Place the engine up side down.
Loosen the 10 mm bolt, 8 mm bolts (six) and 6 mm (ten) bolts in a crisscross pattern in two to three steps.
Loosen the 8 mm bolts (main journal bolts) in a criss-cross pattern in two to three steps, then remove the bolts.
Separate the lower crankcase from the upper crankcase.

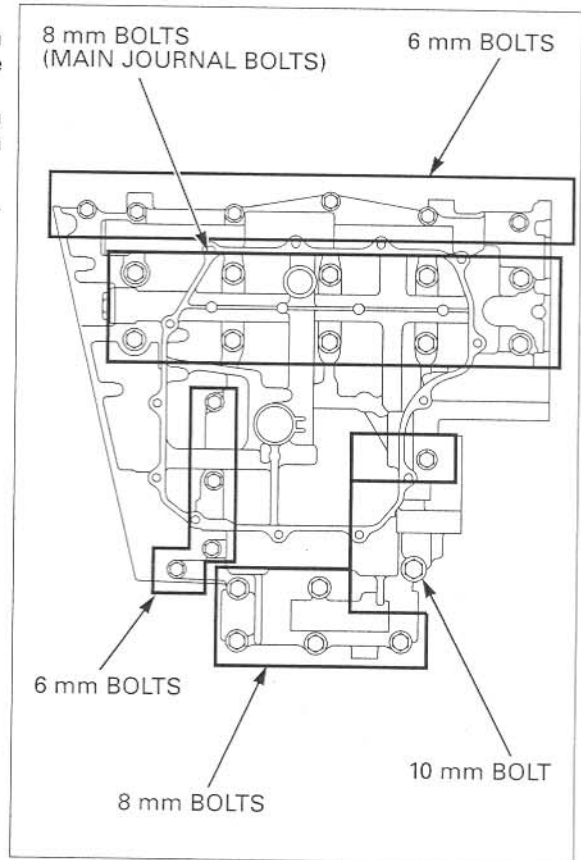

Remove the three dowel pins and two oil orifices.
Clean any sealant off from the crankcase mating surface.

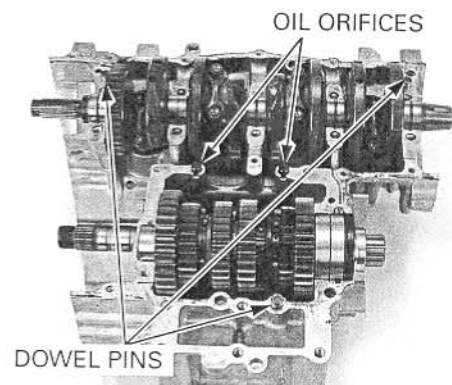

SHIFT FORK/SHIFT DRUM/ TRANSMISSION

REMOVAL/DISASSEMBLY

Separate the crankcase halves (page 12-5).

Remove the countershaft assembly.

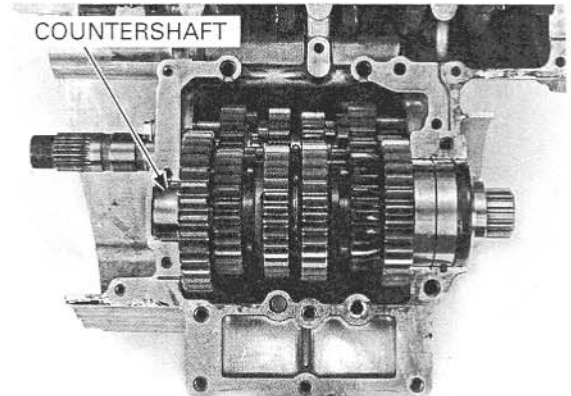

Remove the dowel pin and countershaft bearing set ring.

Disassemble the countershaft.

Clean all disassembled parts in solvent thoroughly.

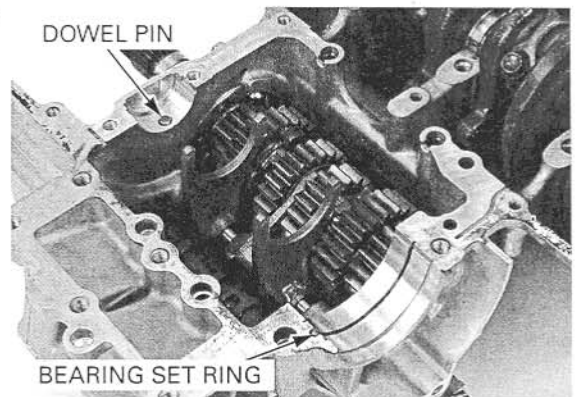

Remove the shift drum bearing set plate bolts/washers.

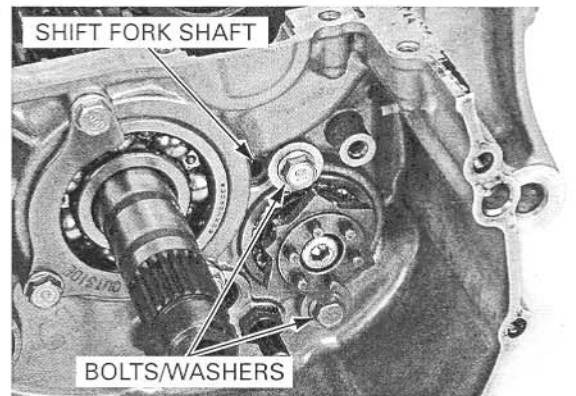

Remove the fork shaft and shift forks.

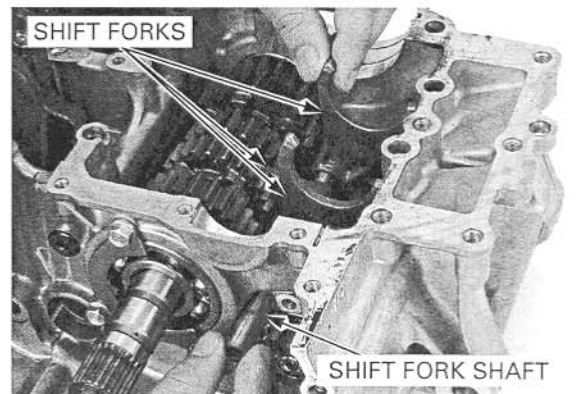

CRANKCASE/TRANSMISSION

Remove the shift drum assembly.

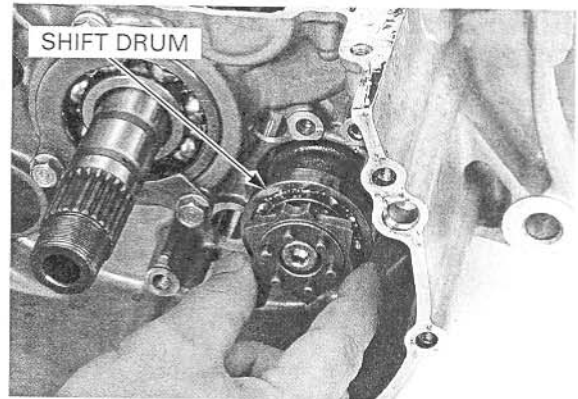

Remove the mainshaft bearing set plate bolts and plate.

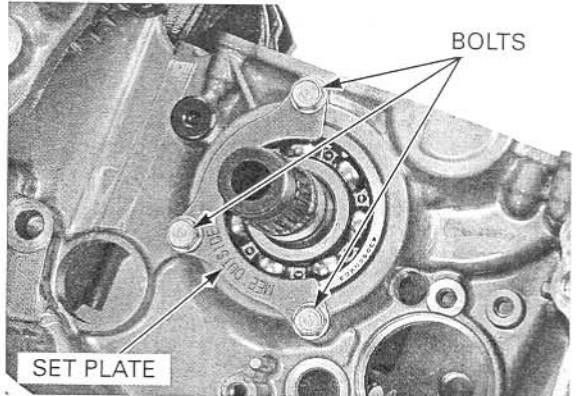

Remove the mainshaft bearing from the crankcase.
Check the mainshaft bearing for smooth rotation, abnormal wear or damage.

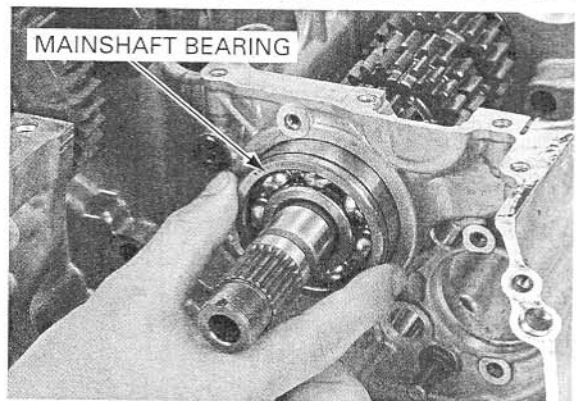

Remove the mainshaft assembly.
Disassemble the mainshaft.
Clean all disassembled parts in solvent thoroughly.

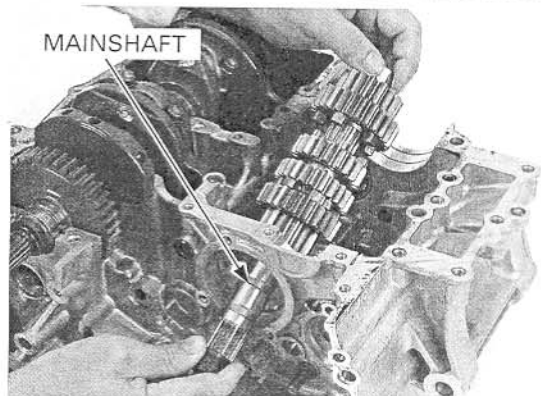

SHIFT DRUM/SHIFT FORK INSPECTION

Check the shift fork guide pin for abnormal wear or damage

Measure the shift fork I.D.

SERVICE LIMIT: 12.03 mm (0.474 in)

Measure the shift fork claw thickness.

SERVICE LIMIT: 5.9 mm (0.23 in)

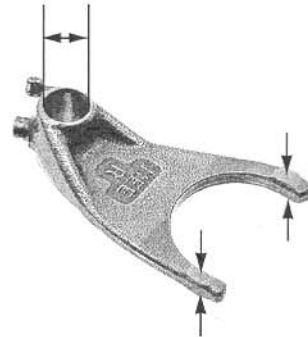

Measure the shift fork shaft O.D.

SERVICE LIMIT: 11.95 mm (0.470 in)

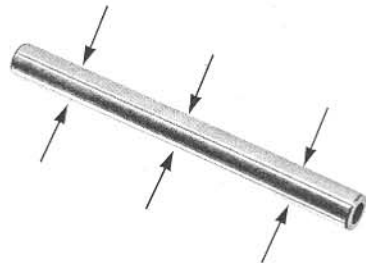

Inspect the shift drum guide grooves for abnormal wear or damage.

Turn the outer race of the shift drum bearing with your finger.

The bearing should turn smoothly and freely without excessive play.

Also check that the bearing inner race fits tightly on the shift drum.

If necessary, replace the bearing.

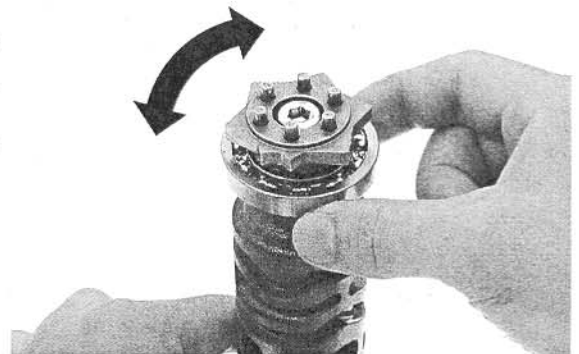

TRANSMISSION INSPECTION

Check the gear shifter groove for abnormal wear or damage.

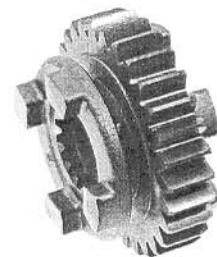

CRANKCASE/TRANSMISSION

Check the gear dogs, dog holes and teeth for abnormal wear or lack of lubrication.

Measure the I.D. of each gear.

SERVICE LIMITS:

M5, M6: 28.04 mm (1.104 in)
C1: 26.04 mm (1.025 in)
C2, C3, C4: 31.04 mm (1.222 in)

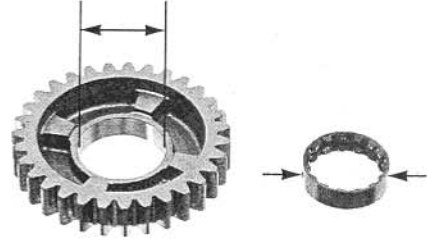

Measure the O.D. of each gear bushing.

SERVICE LIMITS:

M5, M6: 27.94 mm (1.100 in)
C2: 30.94 mm (1.218 in)
C3, C4: 30.93 mm (1.218 in)

Measure the I.D. of each gear bushing.

SERVICE LIMITS:

M5: 25.016 mm (0.9849 in)
C2: 28.021 mm (1.1032 in)

Calculate the gear-to-bushing clearance.

SERVICE LIMITS:

M5, M6: 0.10 mm (0.004 in)
C2: 0.10 mm (0.004 in)
C3, C4: 0.11 mm (0.004 in)

Check the mainshaft and countershaft for abnormal wear or damage.

Measure the mainshaft O.D. at the M5 gear.

SERVICE LIMIT: 24.96 mm (0.983 in)

Measure the countershaft O.D. at the C2 gear.

SERVICE LIMIT: 27.96 mm (1.101 in)

Calculate the gear bushing-to-shaft clearance.

SERVICE LIMITS:

M5: 0.06 mm (0.002 in)
C2: 0.06 mm (0.002 in)

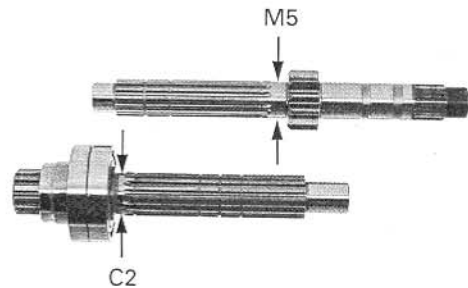

Countershaft bearing

Turn the outer race of countershaft bearing with your finger.

The bearing should turn smoothly and quietly.

Also check that the bearing inner race fits tightly on the shaft.

Replace the countershaft, collar, and bearing as an assembly, if the race does not turn smoothly, quietly, or fits loosely on the countershaft.

- The countershaft bearing cannot be replaced. If the countershaft bearing is faulty, replace the countershaft as an assembly.

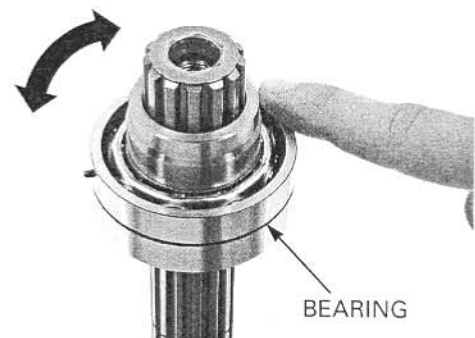

Mainshaft bearing

Turn the inner race of the mainshaft bearings with your finger:
The bearings should turn smoothly and quietly.
Also check that the outer race of the bearing fits tightly in the crankcase.
Replace the bearings if the inner race does not turn smoothly, quietly, or if the outer race fit loosely in the crankcase.

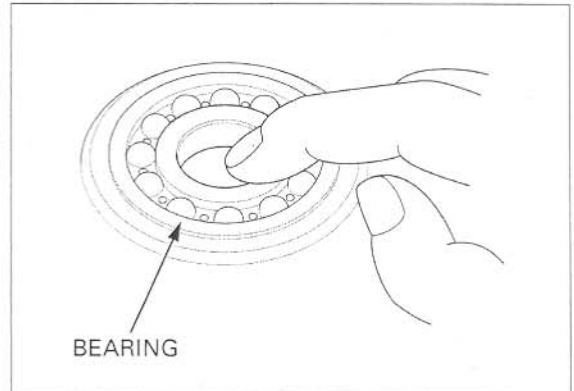

MAINSHAFT BEARING REPLACEMENT

Remove the crankshaft/ (page 13-5) and piston (page 13-13).

Remove the mainshaft bearing using the special tools as shown.

TOOLS:

- | | |
|----------------------------|--|
| Bearing remover set, 20 mm | 07936-3710600 |
| Remover weight | 07741-0010201 or
07936-371020A
(U.S.A. only) |
| Remover handle | 07936-3710100 |

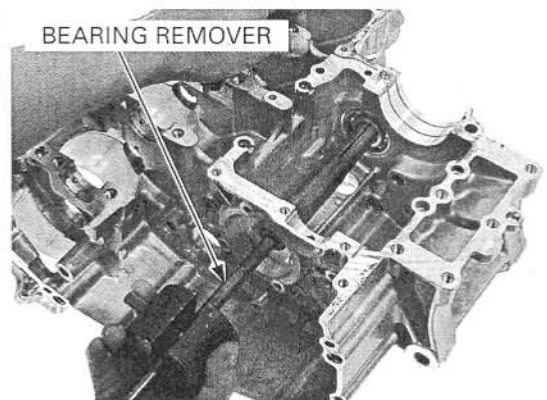

Drive in the new bearing squarely with the marking side facing toward the inside of the crankcase.

Drive new bearing into the left crankcase using the special tools.

TOOLS:

- | | |
|------------------------|---------------|
| Driver | 07949-3710001 |
| Attachment, 42 x 47 mm | 07746-0010300 |
| Pilot, 20 mm | 07746-0040500 |

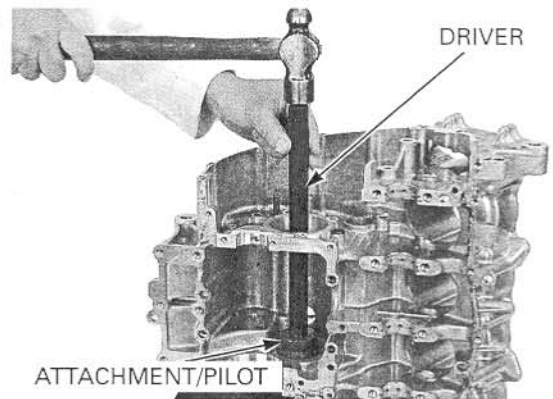

CRANKCASE/TRANSMISSION

TRANSMISSION ASSEMBLY

Apply molybdenum oil solution to the gear teeth, sliding surface, shifter grooves and bushings.

Assemble the mainshaft and countershaft.

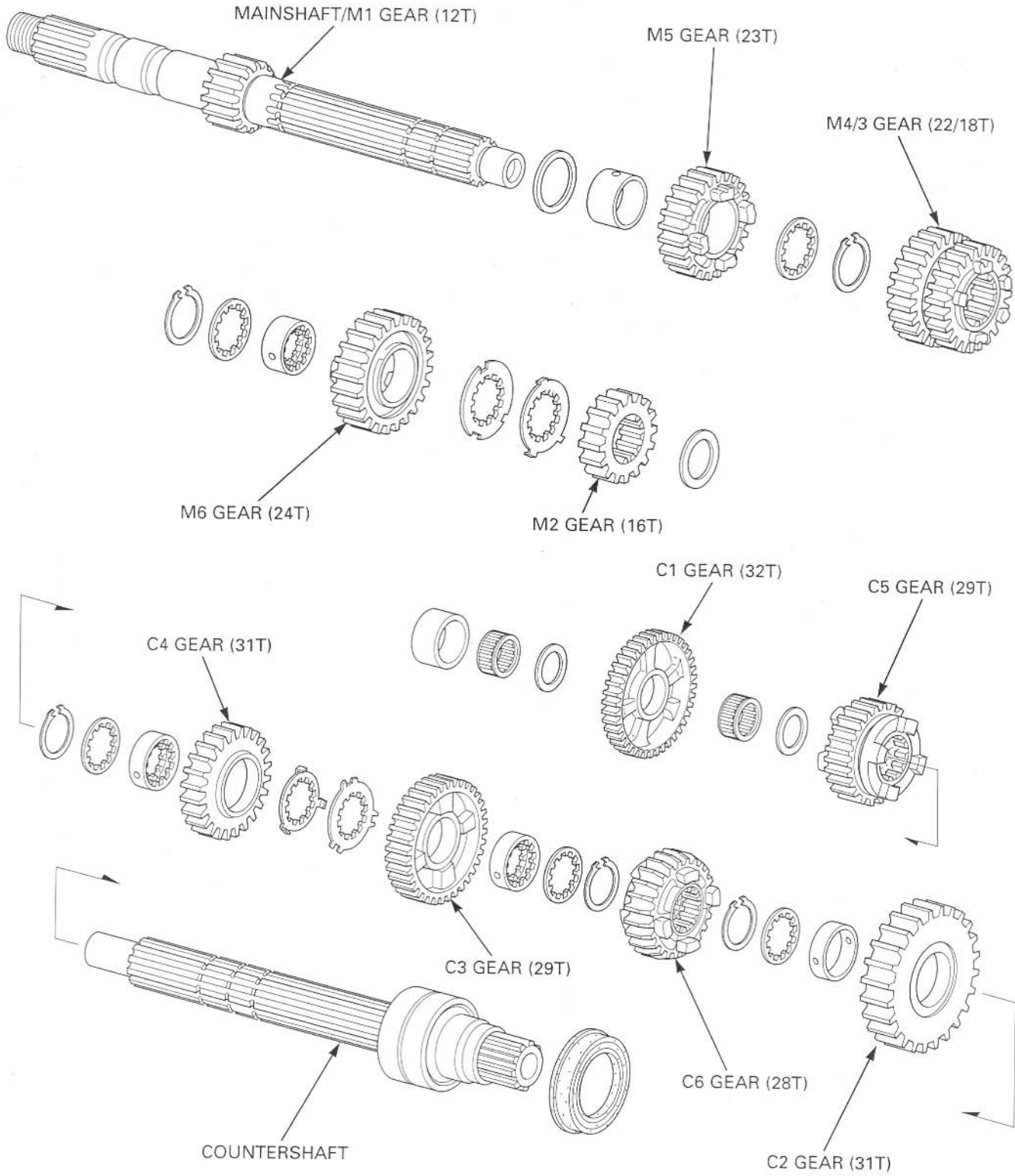

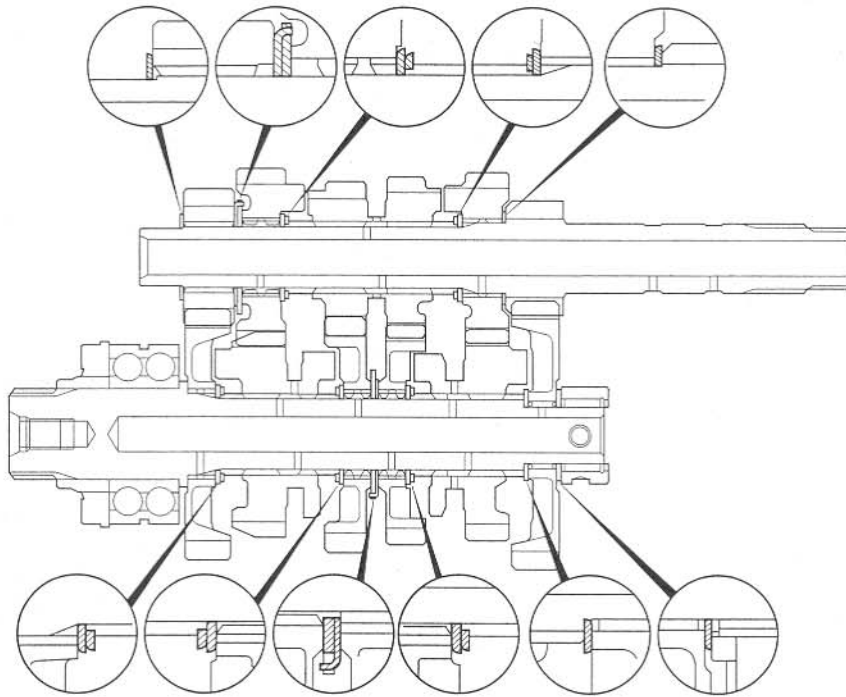

Assemble the transmission gear and shafts.
 Coat each gear with clean engine oil and check for smooth movement.
 Align the oil holes in the M6 bushing and mainshaft, and the C3, C4 spline bushings and countershaft.

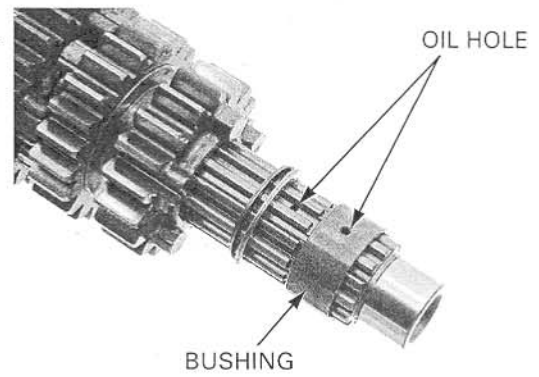

- Align the lock washer tabs with the spline washer grooves.
- Always install the thrust washer and snap ring with the chamfered (rolled) edge facing away from the thrust load.
- Install the snap ring so that its end gap aligns with the groove of the splines.
- Make sure that the snap ring is fully seated in the shaft groove after installing it.

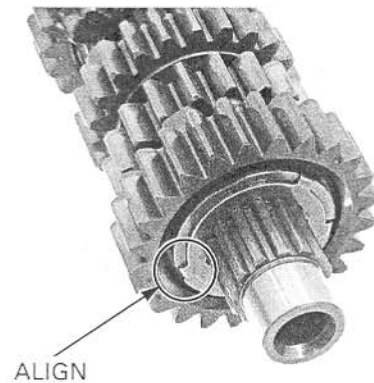

CRANKCASE/TRANSMISSION

INSTALLATION

Apply molybdenum oil solution to the shift fork grooves in the M3/4, C5 and C6 gear.

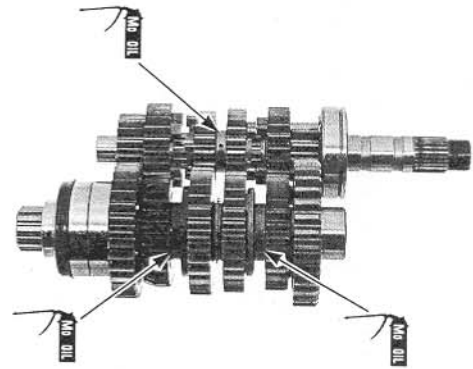

Install the mainshaft into the crankcase.

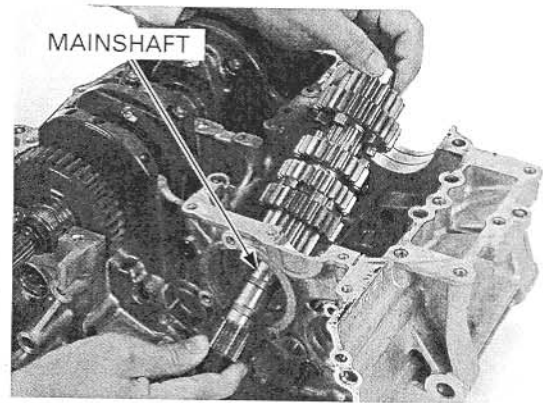

Install the bearing into the crankcase with the marked side facing out.

Install the mainshaft bearing into the crankcase.

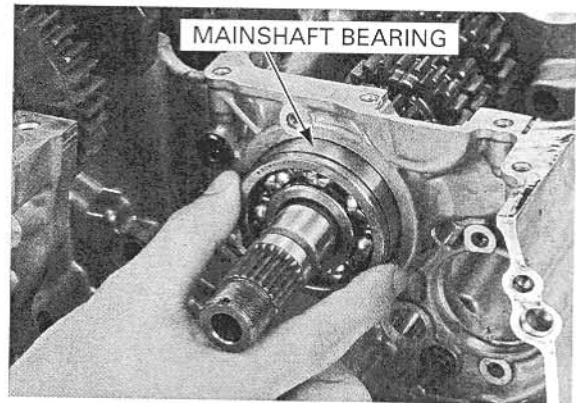

Apply a locking agent to the set plate bolt threads. Install the mainshaft bearing set plate with its "OUT SIDE" mark facing out.

Tighten the set plate bolts to the specified torque.

TORQUE: 12 N·m (1.2 kgf·m, 9 lbf·ft)

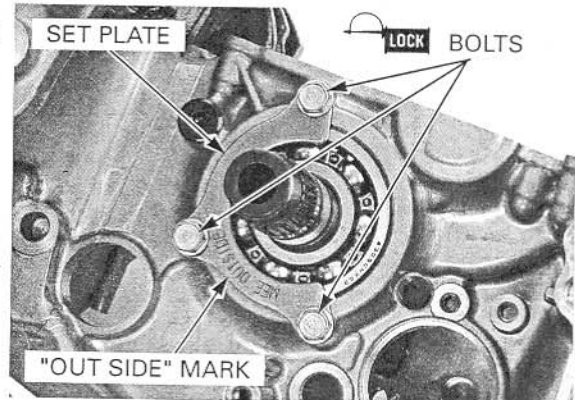

CRANKCASE/TRANSMISSION

Install the shift drum assembly into the crankcase.

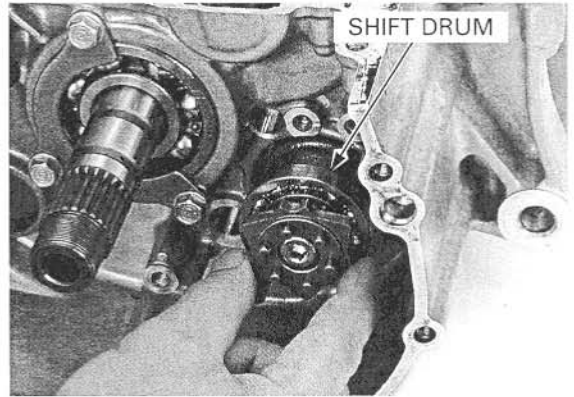

The shift forks have the following identification marks:

- "L" for left
- "R" for right
- "C" for center

IDENTIFICATION MARKS

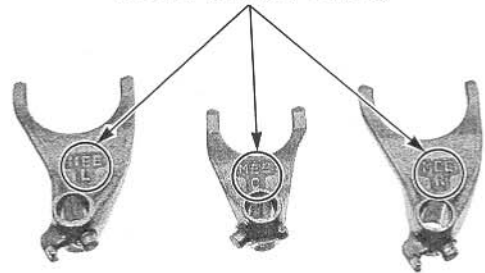

Install the shift forks into the shift drum guide grooves with the identification marks facing toward the right side of the engine and insert the fork shaft.

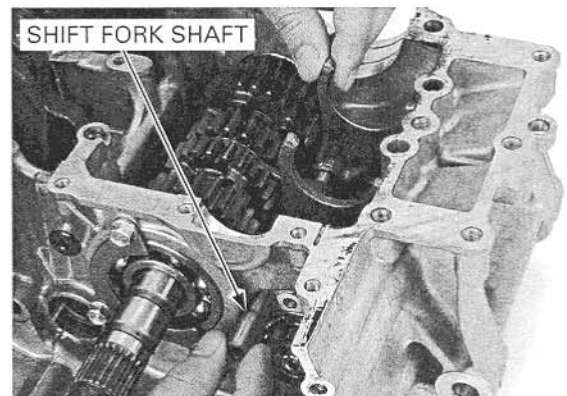

Apply a locking agent to the threads of the bolts/washers.

Tighten the bolts/washers to the specified torque.

TORQUE: 12 N·m (1.2 kgf·m, 9 lbf·ft)

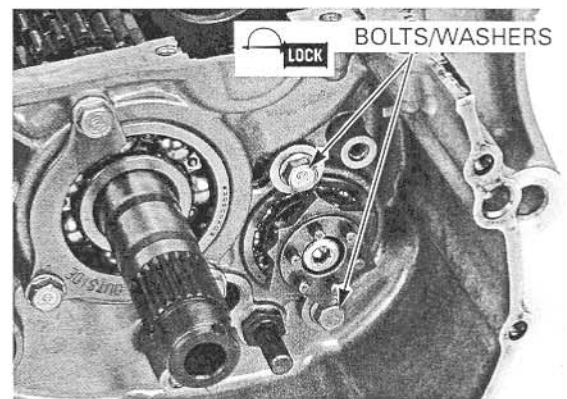

CRANKCASE/TRANSMISSION

Install the dowel pin in the upper crankcase hole.

Install the countershaft bearing set ring into the upper crankcase groove.

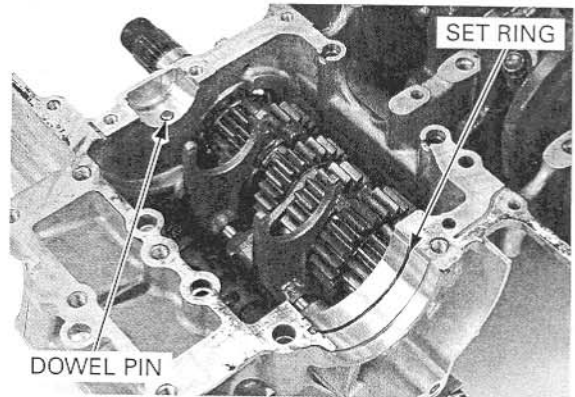

Install the countershaft by aligning the countershaft bearing groove with the set ring on the crankcase, and bearing cap hole with the dowel pin.

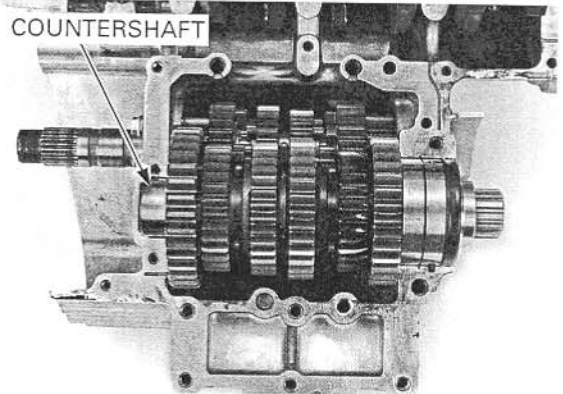

Also align the countershaft bearing stopper pin with the groove in the crankcase.

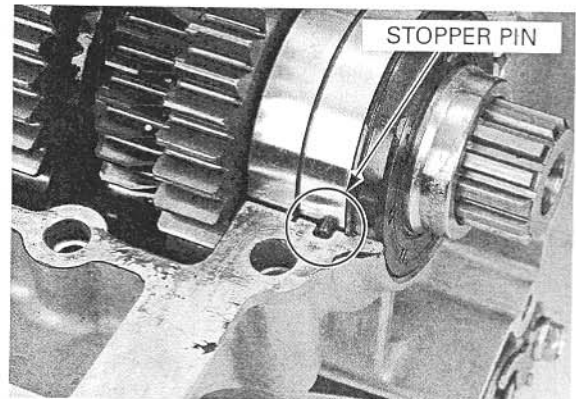

CRANKCASE ASSEMBLY

Apply a light, but thorough, coating of liquid sealant to the crankcase mating surface. Do not apply sealant to the crankcase 8 mm bolt (main journal bolt) area and the oil passage area as shown.

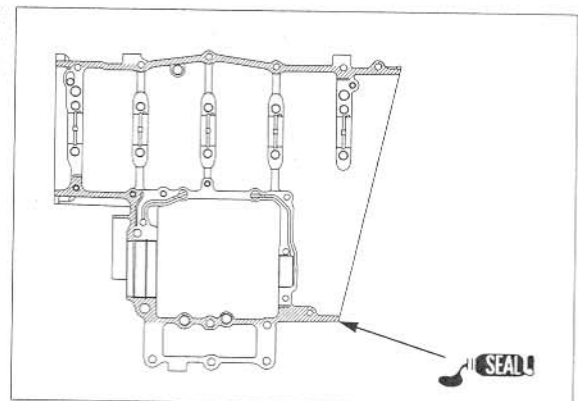

CRANKCASE/TRANSMISSION

Install the three dowel pins.
Install the oil orifices in the upper crankcase.

NOTE:

- Right oil orifice: Align its pin with the crankcase groove as shown.
- Left oil orifice: Align its cut-out with the crankcase.

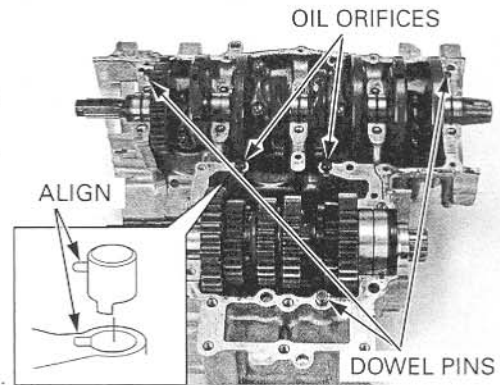

- Tighten the crankcase 8 mm bolts (main journal bolts) using the Plastic Region Tightening Method described below.
- Do not reuse the crankcase 8 mm bolts (main journal bolts), because the correct axial tension will not be obtained.
- The crankcase 8 mm bolts (main journal bolts) are pre-coated with an oil additive for axial tension stability. Do not remove the oil additive from the new 8 mm bolts (main journal bolts) surface.

Install the lower crankcase onto the upper crankcase.

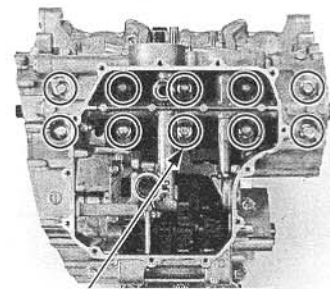

CRANKCASE 8 mm BOLTS
(MAIN JOURNAL BOLTS)

PLASTIC REGION TIGHTENING METHOD:

Install new crankcase 8 mm bolts (main journal 8 mm bolts).

Loosely install all the crankcase bolts.

Make sure the upper and lower crankcase are seated securely.

Tighten the crankcase 8 mm bolts (main journal bolts) as follow:

Tighten the crankcase 8 mm bolts (main journal bolts) in numerical order in the illustration in two to three steps to the specified torque.

Further tighten the crankcase 8 mm bolts (main journal bolts) 120-degrees.

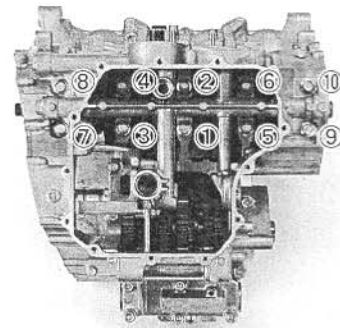

TORQUE: 15 N·m (1.5 kgf·m, 10 lbf·ft) + 120°

CRANKCASE/TRANSMISSION

Tighten the 10 mm bolt to the specified torque.

TORQUE: 39 N·m (4.0 kgf·m, 29 lbf·ft)

From the inside to outside, tighten the 6 mm bolts and 8 mm bolts to the specified torque.

TORQUE:

8 mm bolt: 25 N·m (2.5 kgf·m, 18 lbf·ft)

6 mm bolt: 12 N·m (1.2 kgf·m, 9 lbf·ft)

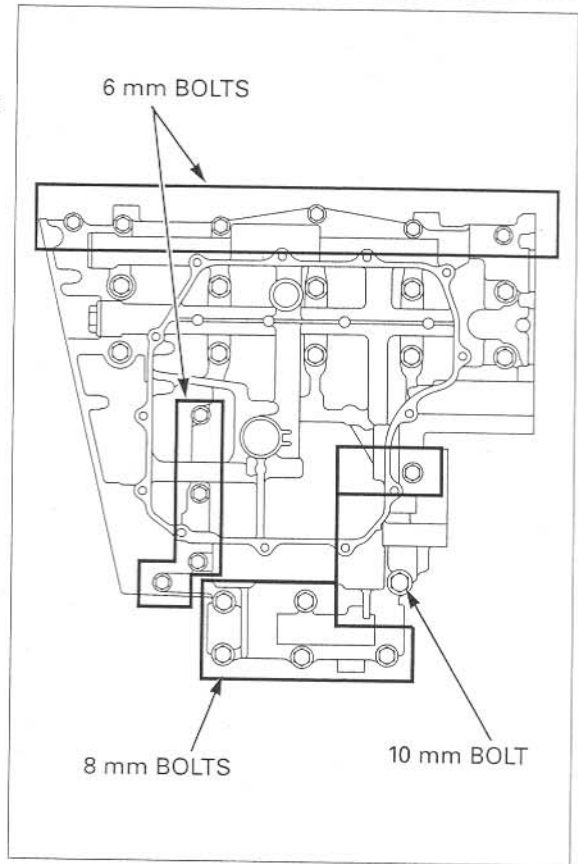

Place the engine with the lower side down.

The sealing washer locations are indicated on the upper crankcase using the '△' mark.

Install the upper crankcase three 6 mm bolts with a new sealing washer.

Tighten the 6 mm bolts securely.

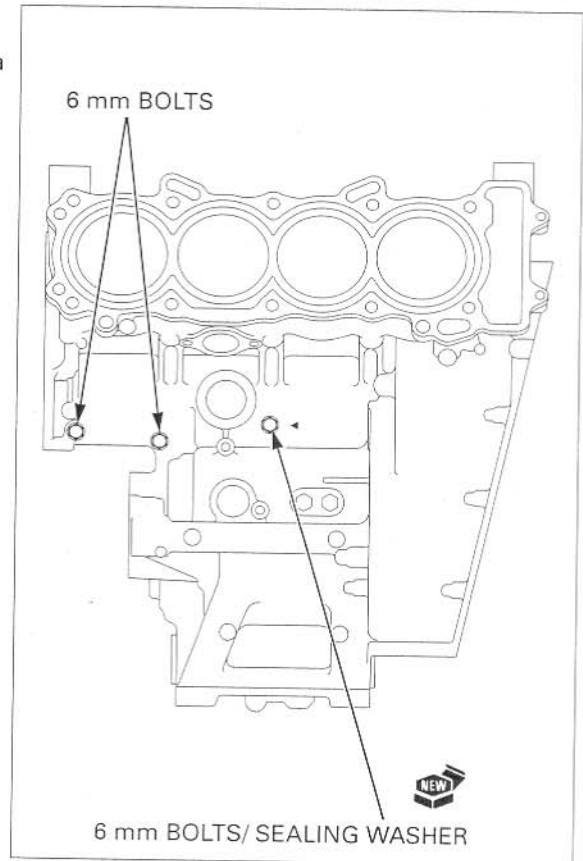

CRANKCASE/TRANSMISSION

Apply oil to a new O-ring and install it into the oil inspection window groove.
Install the oil inspection window onto the lower crankcase.
Install and tighten the bolts securely.



Apply a sealant to the oil pressure switch threads as shown.
Tighten the oil pressure switch to the specified torque while holding the switch base.

TORQUE: 12 N·m (1.2 kgf·m, 9 lbf·ft)

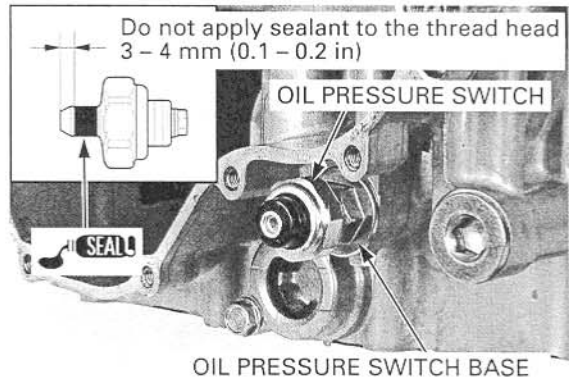

Install the vehicle speed sensor, tighten the bolt and clamp securely.

Tighten the neutral switch with a new sealing washer to the specified torque.

TORQUE: 12 N·m (1.2 kgf·m, 9 lbf·ft)

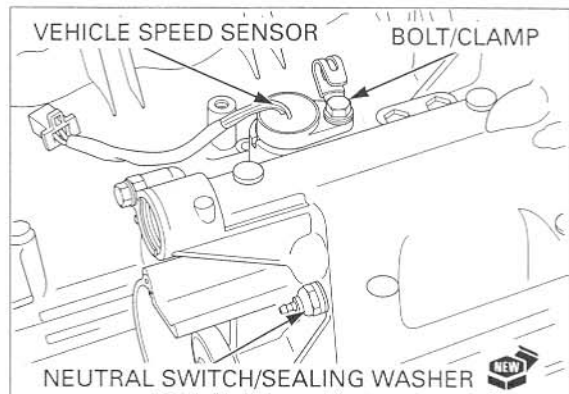

Install a new O-ring into the groove of the water hose joint.
Install the water hose joint to the cylinder block.

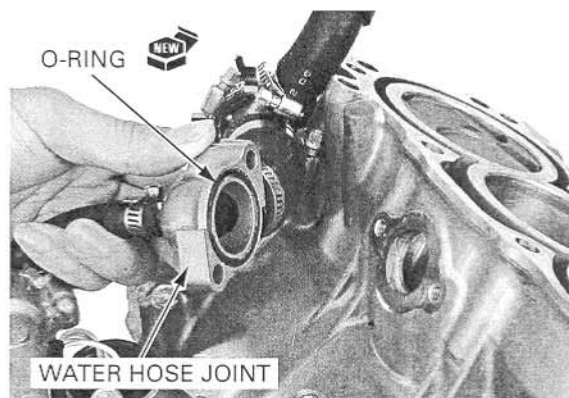

CRANKCASE/TRANSMISSION

Tighten the bolts securely.

Install the removed parts in the reverse order of removal.

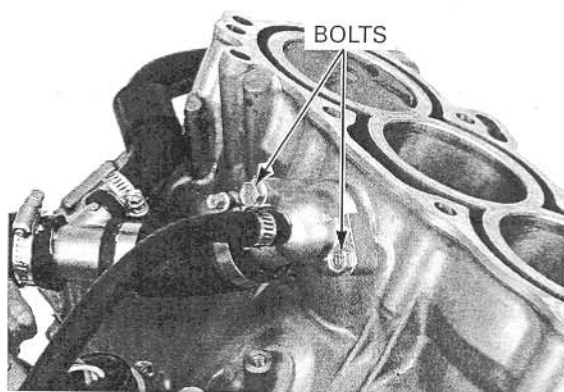

13. CRANKSHAFT/PISTON/CYLINDER

COMPONENT LOCATION	13-2	MAIN JOURNAL BEARING.....	13-8
SERVICE INFORMATION	13-3	CRANKPIN BEARING	13-11
TROUBLESHOOTING.....	13-4	PISTON/CYLINDER	13-13
CRANKSHAFT.....	13-5		

CRANKSHAFT/PISTON/CYLINDER

COMPONENT LOCATION

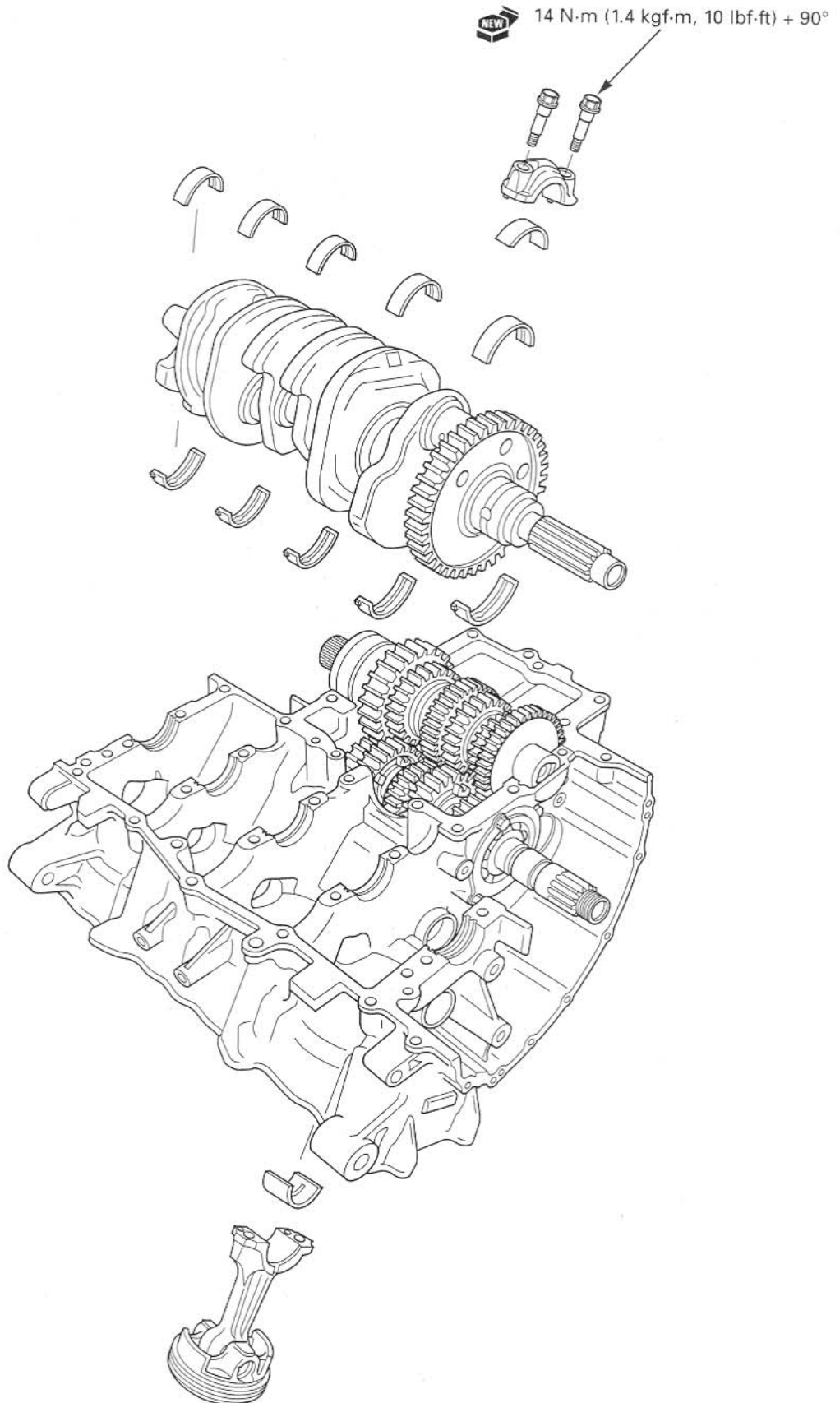

SERVICE INFORMATION

GENERAL

- The crankcase must be separated to service the crankshaft, cylinder and piston/connecting rod. Refer to procedures for crankcase separation (page 12-5) and assembly (page 12-16).
- Mark and store the connecting rods, bearing caps and bearing inserts to be sure of their correct locations for reassembly.
- The crankpin and main journal bearing inserts are select fit and are identified by color codes. Select replacement bearings from the code tables. After selecting new bearings, recheck the oil clearance with a plastigauge. Incorrect oil clearance can cause major engine damage.
- Clean the oil jets in the upper crankcase with compressed air before installing the pistons.

SPECIFICATIONS

Unit: mm (in)

ITEM		STANDARD	SERVICE LIMIT	
Crankshaft	Connecting rod side clearance	0.15 – 0.30 (0.006 – 0.012)	0.35 (0.014)	
	Crankpin bearing oil clearance	0.028 – 0.052 (0.0011 – 0.0020)	0.06 (0.002)	
	Main journal bearing oil clearance	0.020 – 0.038 (0.0008 – 0.0015)	0.05 (0.002)	
	Runout	–	0.05 (0.002)	
Piston, piston rings	Piston O.D. at 10 (0.4) from bottom	66.965 – 66.985 (2.6364 – 2.6372)	66.90 (2.634)	
	Piston pin bore I.D.	16.002 – 16.008 (0.6300 – 0.6302)	16.02 (0.631)	
	Piston pin O.D.	15.994 – 16.000 (0.6297 – 0.6299)	15.98 (0.629)	
	Piston-to-piston pin clearance	0.002 – 0.014 (0.0001 – 0.0006)	0.04 (0.002)	
	Piston ring end gap	Top	0.10 – 0.20 (0.004 – 0.008)	0.4 (0.02)
		Second	0.21 – 0.31 (0.008 – 0.012)	0.5 (0.02)
		Oil (side rail)	0.2 – 0.7 (0.01 – 0.03)	1.0 (0.04)
	Piston ring-to-ring groove clearance	Top	0.030 – 0.060 (0.0012 – 0.0024)	0.10 (0.004)
Second		0.015 – 0.050 (0.0006 – 0.0020)	0.08 (0.003)	
Cylinder	I.D.	67.000 – 67.015 (2.6378 – 2.6384)	67.10 (2.642)	
	Out of round	–	0.10 (0.004)	
	Taper	–	0.10 (0.004)	
	Warpage	–	0.10 (0.004)	
Cylinder-to-piston clearance		0.015 – 0.050 (0.0006 – 0.0022)	0.10 (0.004)	
Connecting rod small end I.D.		16.010 – 16.034 (0.6303 – 0.6313)	16.050 (0.6319)	
Connecting rod-to-piston pin clearance		0.010 – 0.040 (0.0004 – 0.0016)	0.070 (0.0028)	

TORQUE VALUES

Connecting rod bearing cap bolt 14 N·m (1.4 kgf·m, 10 lbf·ft) + 90° Apply oil to the threads and seating surface

CRANKSHAFT/PISTON/CYLINDER

TROUBLESHOOTING

Cylinder compression is too low, hard to starting or poor performance at low speed

- Leaking cylinder head gasket
- Worn, stuck or broken piston ring
- Worn or damaged cylinder and piston

Cylinder compression too high, overheating or knocking

- Excessive carbon built-up on piston head or combustion chamber

Excessive smoke

- Worn cylinder, piston or piston ring
- Improper installation of piston rings
- Scored or scratched piston or cylinder wall

Abnormal noise

- Worn piston pin or piston pin hole
- Worn connecting rod small end
- Worn cylinder, piston or piston rings
- Worn main journal bearings
- Worn crankpin bearings

Engine vibration

- Excessive crankshaft runout

CRANKSHAFT

Separate the crankcase halves (page 12-5).

SIDE CLEARANCE INSPECTION

Measure the connecting rod side clearance.

SERVICE LIMIT: 0.35 mm (0.014 in)

If the clearance exceeds the service limit, replace the connecting rod.

Recheck and if still out of limit, replace the crankshaft.

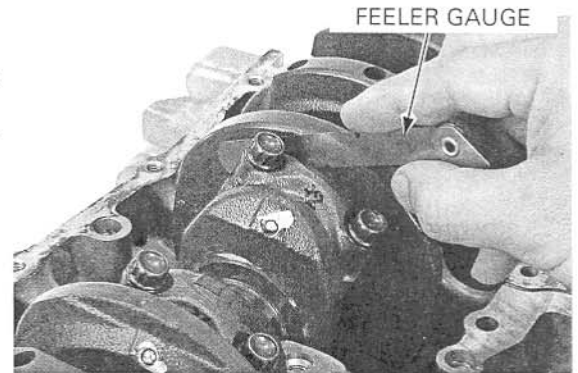

REMOVAL

NOTICE

Before removal, position all the pistons at TDC (Top Dead Center) to prevent damaging the crankpin with the connecting rod.

Mark the bearing caps and bearings as you remove them to indicate the correct cylinder for reassembly.

Remove the connecting rod bearing cap bolts and bearing caps.

Tap the side of the cap lightly if the bearing cap is hard to remove.

Remove the crankshaft.

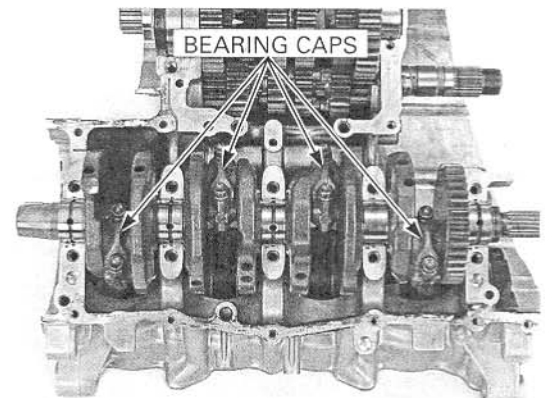

Remove the main journal bearings from both the crankcase halves.

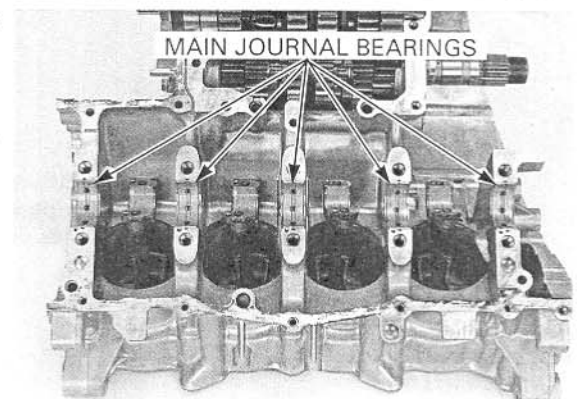

CRANKSHAFT/PISTON/CYLINDER

Remove the crankshaft oil jets from the upper crankcase.

Always replace the O-ring when the oil jets are removed.

Inspect the oil jets for clogs, and replace it if necessary.

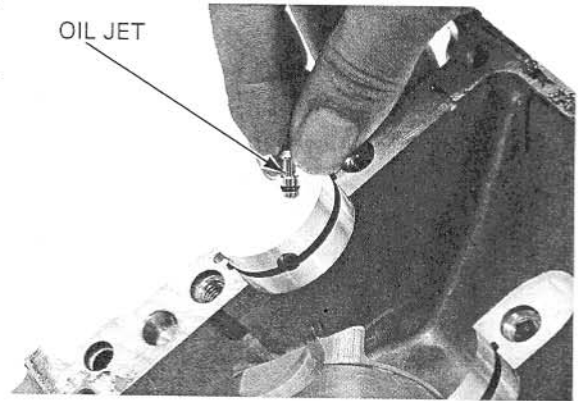

INSPECTION

Support the crankshaft on both end journals. Set a dial gauge on the center main journal of the crankshaft. Rotate the crankshaft two revolutions and read the runout.

SERVICE LIMIT: 0.05 mm (0.002 in)

Check the primary drive gear teeth for abnormal wear or damage.

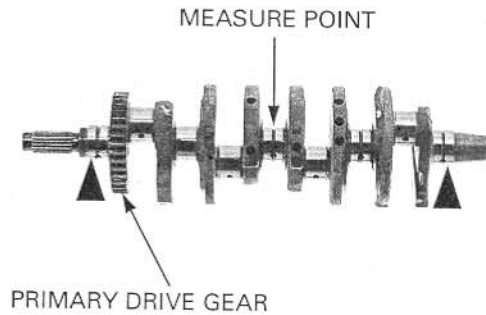

INSTALLATION

Apply engine oil to a new O-ring and install it to the oil jet.

Install the crankcase oil jets into the upper crankcase main journal.

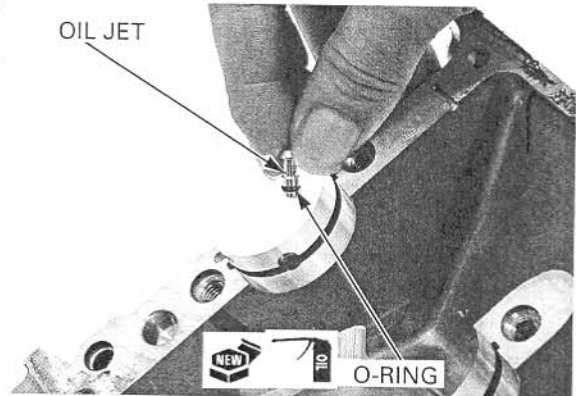

Apply molybdenum oil solution to the main journal bearing sliding surfaces on the upper crankcase and the crankpin bearing sliding surfaces on the connecting rods.

The bearing tabs should be aligned with the grooves in the crankcase.

Install the main journal bearings into the upper crankcase.

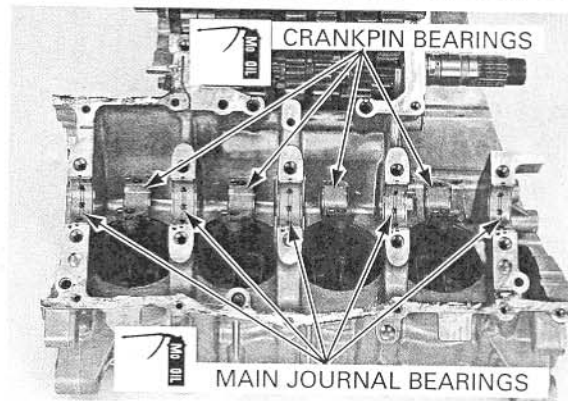

CRANKSHAFT/PISTON/CYLINDER

Apply molybdenum oil solution to the thrust surfaces of the crankshaft as shown.

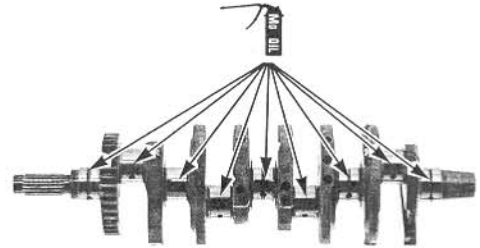

NOTICE

Position all the pistons at TDC (Top Dead Center) to prevent damaging the crankpin with the connecting rod.

Install the crankshaft onto the upper crankcase. Set the connecting rods onto the crankpins.

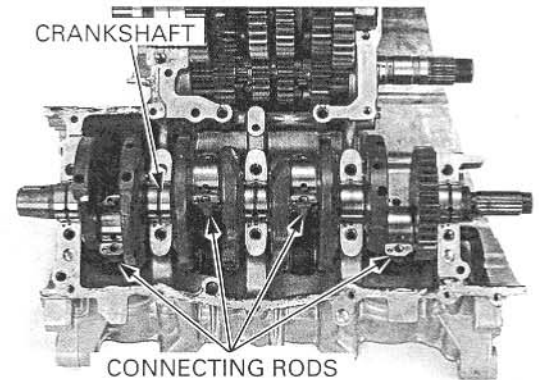

Apply molybdenum oil solution to the crankpin bearing sliding surfaces on the connecting rod bearing caps.

Install the connecting rod bearing caps, aligning the dowel pins with the holes in the connecting rods. Be sure each part is installed in its original position, as noted during removal.

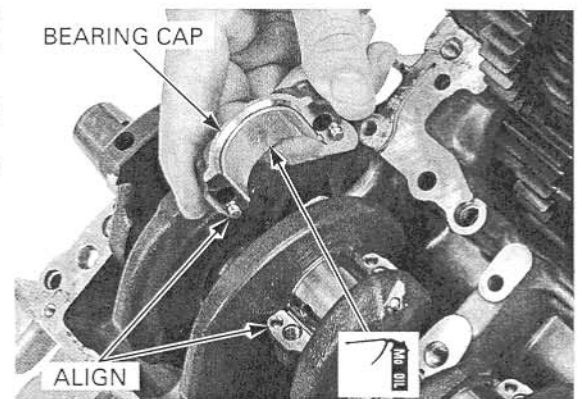

The connecting rod bolts cannot be reused. Once the connecting rod bolts have been loosened replace them with new ones.

Apply oil to new connecting rod bearing cap bolt threads and seating surfaces, and install the bolts.

Tighten the bolts in two or three steps alternately.

Further tighten the bolts 90 degrees.

TORQUE: 14 N·m (1.4 kgf·m, 10 lbf·ft) + 90°

Assemble the upper and lower crankcase (page 12-16).

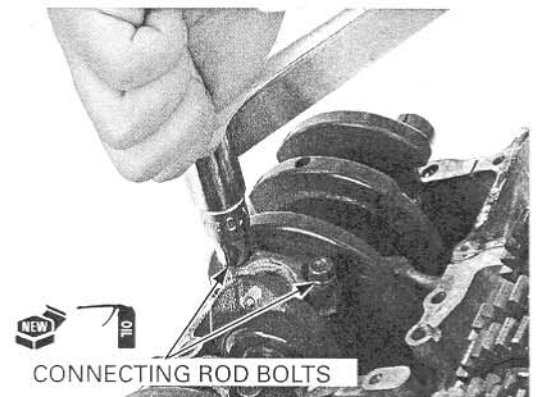

CRANKSHAFT/PISTON/CYLINDER

MAIN JOURNAL BEARING

NOTICE

Do not interchange the bearing inserts. They must be installed in their original locations or the correct bearing oil clearance may not be obtained, resulting in engine damage.

Remove the crankshaft (page 13-5).

BEARING INSPECTION

Inspect the main journal bearing inserts on the upper and lower crankcase halves for unusual wear or peeling.

Check the bearing tabs for damage.

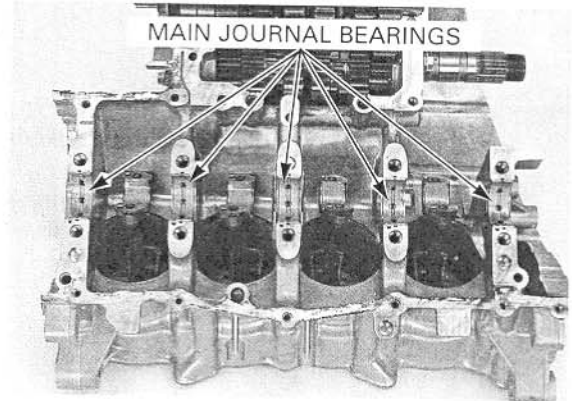

OIL CLEARANCE INSPECTION

Clean off any oil from the bearing inserts and main journals.

Install the crankshaft onto the upper crankcase.

Put a strip of plastigauge lengthwise on each main journal avoiding the oil hole.

- Do not rotate the crankshaft during inspection.

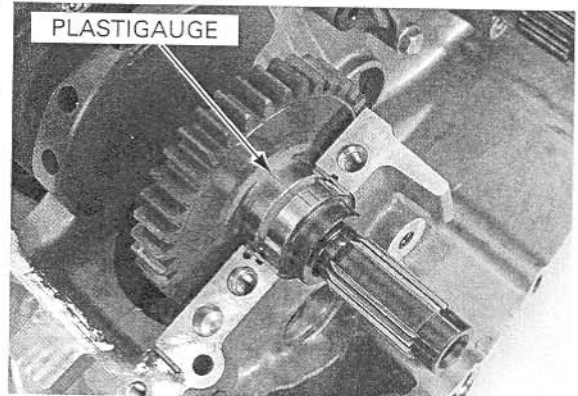

Install the three dowel pins.

Install the oil orifices in the upper crankcase.

NOTE:

- Right oil orifice: Align its pin with the crankcase groove as shown.
- Left oil orifice: Align its cut-out with the crankcase.

Install the lower crankcase onto the upper crankcase.

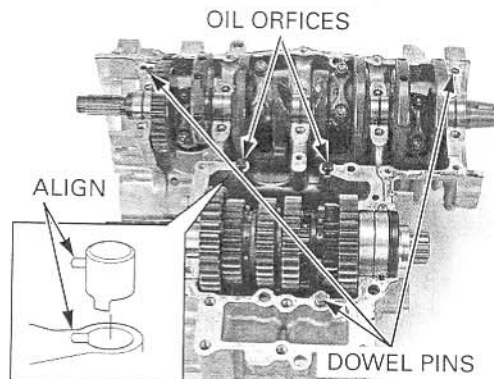

PLASTIC REGION TIGHTENING METHOD:

Install the crankcase 8 mm bolts (main journal 8 mm bolts).

Loosely install all the crankcase bolts.

Make sure the upper and lower crankcase are seated securely.

Tighten the crankcase 8 mm bolts (main journal bolts) as follow:

Tighten the crankcase 8 mm bolts (main journal bolts) in numerical order in the illustration in two to three steps to the specified torque.

Further tighten the crankcase 8 mm bolts (main journal bolts) 120 degrees.

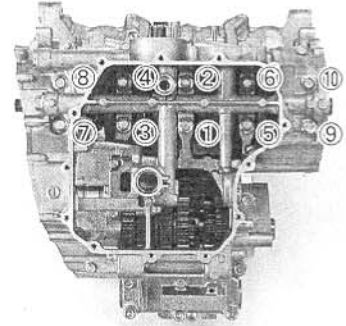

TORQUE: 15 N·m (1.5 kgf·m, 10 lbf·ft) +120°

Remove the crankcase 8 mm bolts (main journal bolts) and lower crankcase, measure the compressed plastigauge at its widest point on each main journal to determine the oil clearance.

SERVICE LIMIT: 0.05 mm (0.002 in)

If the oil clearance exceeds the service limit, select a replacement bearing.

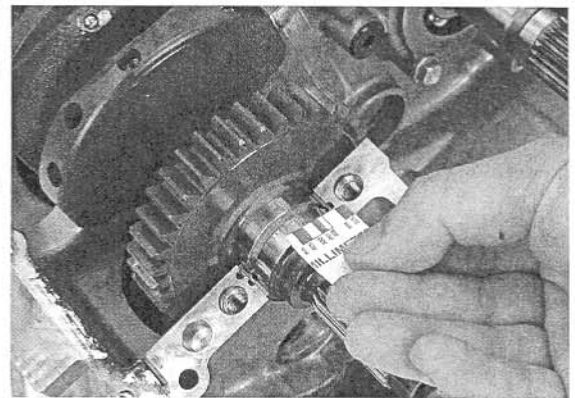

BEARING SELECTION

Record the crankcase bearing support I.D. code letters from the pad on the left side of the upper crankcase as shown.

Letters (A, B or C) on the left side of upper crankcase are the codes for the bearing support I.D.s from left to right.

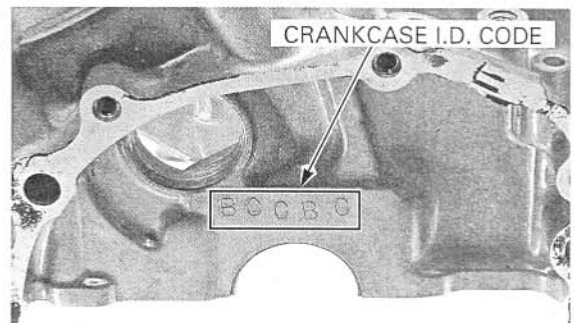

Record the corresponding main journal O.D. code numbers from the crank weight.

Numbers (1, 2 or 3) on the crank weight are the codes for the main journal O.D.s from left to right.

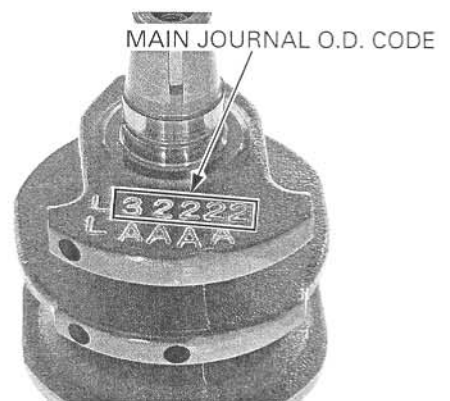

CRANKSHAFT/PISTON/CYLINDER

Cross reference the main journal and bearing support codes to determine the replacement bearing color code.

MAIN JOURNAL BEARING SELECTION TABLE:

			BEARING SUPPORT I.D.CODE		
			A	B	C
			34.000 – 34.006 mm (1.3386 – 1.3388 in)	34.006 – 34.012 mm (1.3388 – 1.3391 in)	34.012 – 34.018 mm (1.3391 – 1.3393 in)
MAIN JOURNAL O.D. CODE	1	30.999 – 31.005 mm (1.2204 – 1.2207 in)	Pink	Yellow	Green
	2	30.993 – 30.999 mm (1.2202 – 1.2204 in)	Yellow	Green	Brown
	3	30.987 – 30.993 mm (1.2200 – 1.2202 in)	Green	Brown	Black

BEARING THICKNESS:

Black: Thickest
Brown: ↓
Green: ↓
Yellow: ↓
Pink: Thinnest

NOTICE

After selecting new bearings, recheck the clearance with a plastigauge. Incorrect clearance can cause severe engine damage.

IDENTIFICATION COLOR

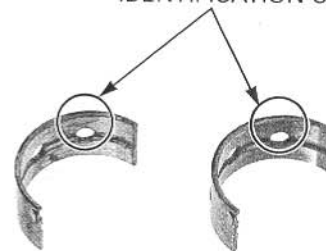

BEARING INSTALLATION

Clean the bearing outer surfaces and crankcase bearing supports.
Install the main journal bearing inserts onto the crankcase bearing supports, aligning each tabs with each grooves.

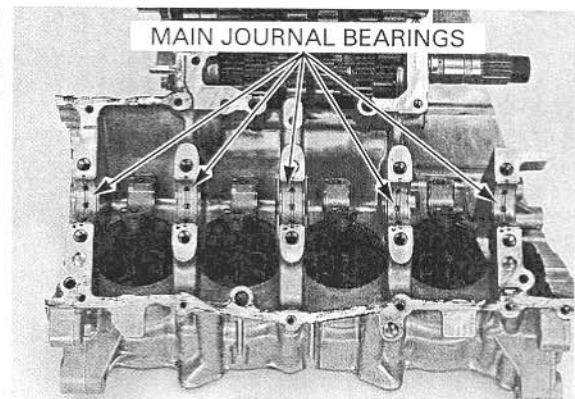

CRANKPIN BEARING

NOTICE

Do not interchange the bearing inserts. They must be installed in their original locations or the correct bearing oil clearance may not be obtained, resulting in engine damage.

Remove the crankshaft (page 13-5).

BEARING INSPECTION

Check the bearing inserts for unusual wear or peeling.
Check the bearing tabs for damage.

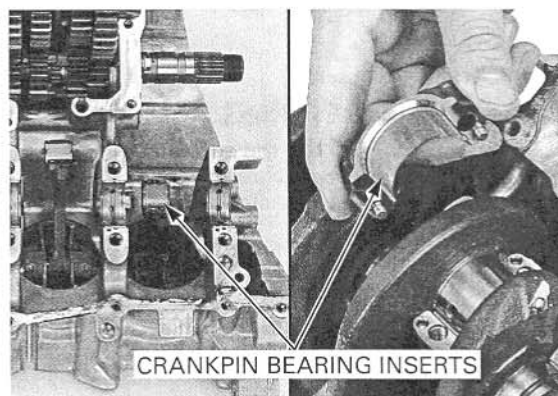

OIL CLEARANCE INSPECTION

Clean off any oil from the bearing inserts and crankpins.

Carefully install the crankshaft onto the upper crankcase.

Set the connecting rods onto the crankpins.

Put a strip of plastigauge lengthwise on each crankpin avoiding the oil hole.

- Do not rotate the crankshaft during inspection.

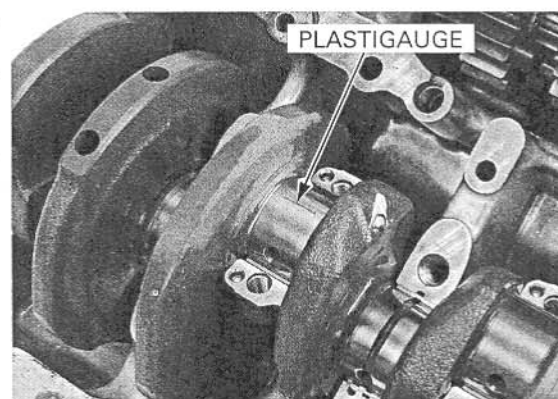

Carefully install the connecting rod bearing caps, aligning the dowel pins with the holes in the connecting rods.

Apply oil to the connecting rod bearing cap bolt threads and seating surfaces and install the bolts. Tighten the bolts in two or three steps alternately.

Further tighten the bolts 90 degrees.

TORQUE: 14 N·m (1.4 kgf·m, 10 lbf·ft) + 90°

Use the removed connecting rod bolts when checking the oil clearance.

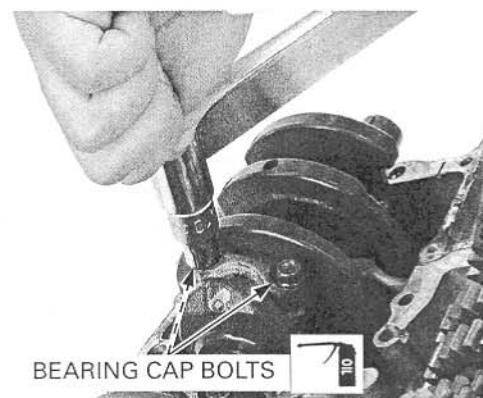

CRANKSHAFT/PISTON/CYLINDER

Remove the bearing caps and measure the compressed plastigauge at its widest point on the crankpin to determine the oil clearance.

SERVICE LIMIT: 0.06 mm (0.002 in)

If the oil clearance exceeds the service limit, select the correct replacement bearings.

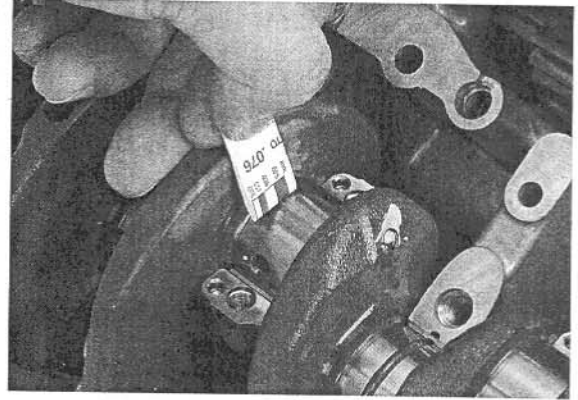

BEARING SELECTION

Numbers (1 or 2) on the connecting rods are the codes for the connecting rod I.D.

Record the connecting rod I.D. code number (1 or 2) or measure the I.D. with the connecting rod bearing cap installed without bearing inserts.

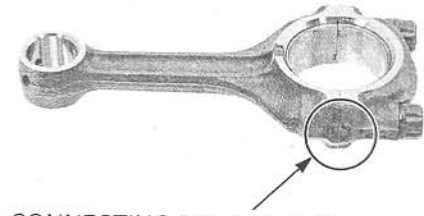

CONNECTING ROD I.D. CODE

Letters (A or B) on the crankweight are the codes for the crankpin O.D.s from left to right.

If you are replacing the crankshaft, record the corresponding crankpin O.D. code letter (A or B).

If you are reusing the crankshaft, measure the crankpin O.D. with the micrometer.

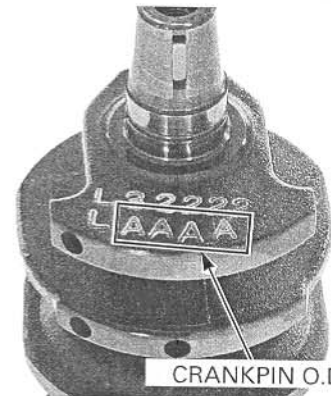

CRANKPIN O.D. CODE

Cross-reference the connecting rod and crankpin codes to determine the replacement bearing color.

CRANKPIN BEARING SELECTION TABLE:

			CONNECTING ROD I.D.CODE	
			1	2
CRANK PIN O.D.CODE	A	30.995 – 31.003 mm (1.2203 – 1.2206 in)	33.500 – 33.508 mm (1.3189 – 1.3192 in)	33.508 – 33.516 mm (1.3192 – 1.3195 in)
		Yellow	Green	
	B	30.984 – 30.995 mm (1.2198 – 1.2203 in)	Green	Brown

BEARING THICKNESS:

Brown: Thickest
Green: ↓
Yellow: Thinnest

NOTICE

After selecting new bearings, recheck the clearance with a plastigauge. Incorrect clearance can cause severe engine damage.

IDENTIFICATION COLOR

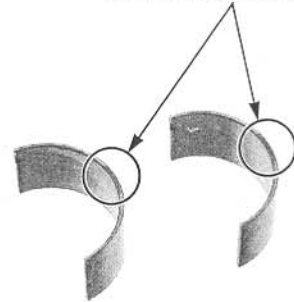

BEARING INSTALLATION

Clean the bearing outer surfaces, connecting rod bearing cap and connecting rod. Install the crankpin bearing inserts onto the bearing cap and connecting rod, aligning each tab with each groove.

BEARINGS

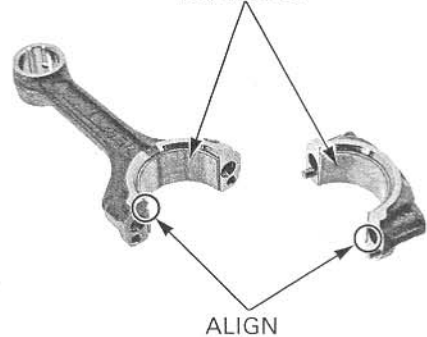

PISTON/CYLINDER

PISTON/CONNECTING ROD REMOVAL

NOTICE

- This motorcycle is equipped with aluminum cylinder sleeves. Before piston removal, place a clean shop towel around the connecting rod to prevent damaging the cylinder sleeve.
- Do not try to remove the piston/connecting rod assembly from bottom of the cylinder; the assembly will get stuck in the gap between the cylinder liner and the upper crankcase.
- Do not interchange the bearing inserts. They must be installed in their original locations or the correct bearing oil clearance may not be obtained, resulting in engine damage.

Mark all parts as you remove them to indicate the correct cylinder for reassembly.

Remove the bolts and connecting rod bearing caps.

BOLTS

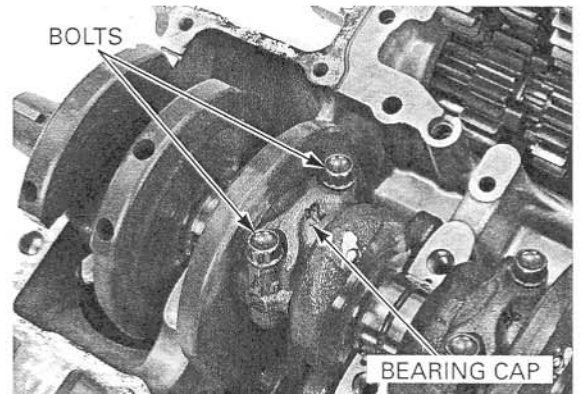

BEARING CAP

CRANKSHAFT/PISTON/CYLINDER

Do not try to remove the connecting rod/piston assembly from the bottom of the cylinder; the assembly will be locked so that the oil ring expands in the gap between the cylinder liner and the upper crankcase.

Remove the piston/connecting rod assembly from the top of the cylinder.

PISTON/CONNECTING ROD ASSEMBLY

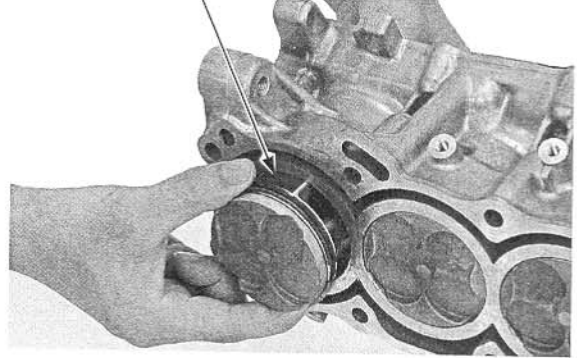

PISTON REMOVAL

Remove the piston pin clip with pliers. Push the piston pin out of the piston and connecting rod, and remove the piston.

PISTON PIN CLIP

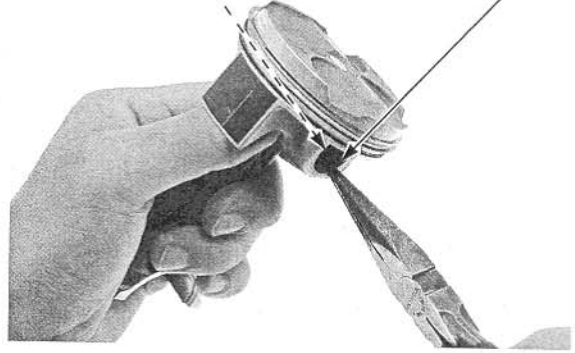

PISTON DISASSEMBLY

Be careful not to damage the piston ring by spreading the ends too far.

Spread each piston ring ends and remove them by lifting up at a point opposite the gap.

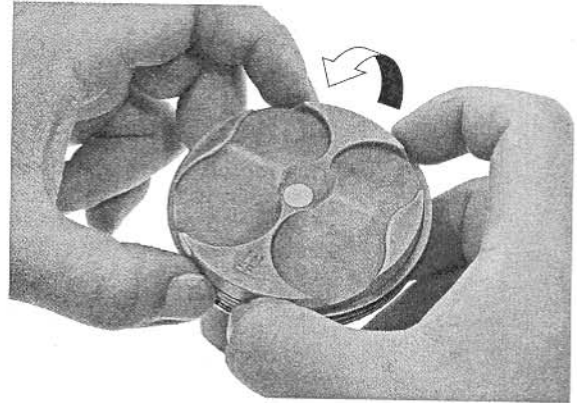

Never use a wire brush; it will scratch the groove.

Clean carbon deposits from the piston ring grooves with a ring that will be discarded.



PISTON INSPECTION

Inspect the piston rings for movement by rotating the rings. The rings should be able to move in their grooves without catching.

Push the ring until the outer surface of the piston ring is nearly flush with the piston and measure the ring-to-ring groove clearance.

SERVICE LIMITS:

- Top: 0.10 mm (0.004 in)**
- Second: 0.08 mm (0.003 in)**

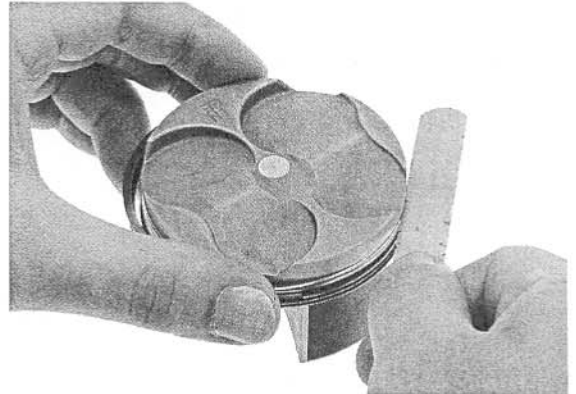

Push the rings into the cylinder with the top of the piston to be sure they are squarely in the cylinder.

Insert the piston ring squarely into the top of the cylinder and measure the ring end gap.

SERVICE LIMITS:

- Top: 0.4 mm (0.02 in)**
- Second: 0.5 mm (0.02 in)**
- Oil (side rail): 1.0 mm (0.04 in)**

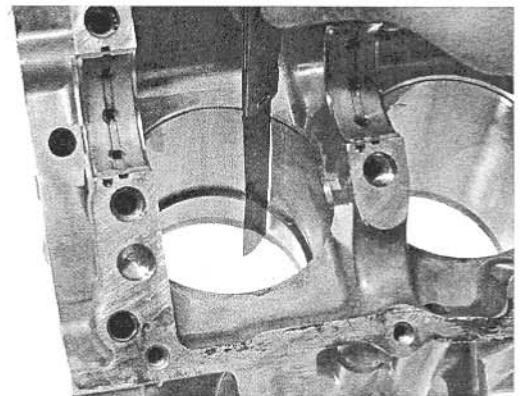

Measure the piston pin bore.

SERVICE LIMIT: 16.02 mm (0.631 in)

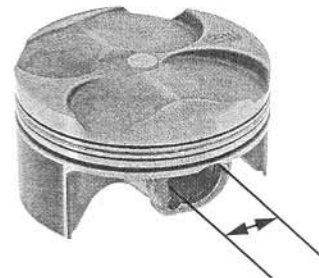

Measure the O.D. of the piston pin.

SERVICE LIMIT: 15.98 mm (0.629 in)

Calculate the piston-to-piston pin clearance.

SERVICE LIMIT: 0.04 mm (0.002 in)

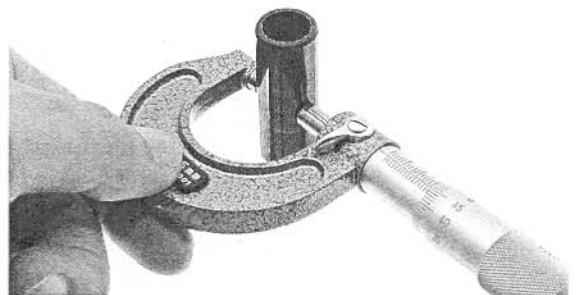

CRANKSHAFT/PISTON/CYLINDER

Measure the diameter of the piston at 10 mm (0.4 in) from the bottom and 90 degrees to the piston pin hole.

SERVICE LIMIT: 66.90 mm (2.634 in)

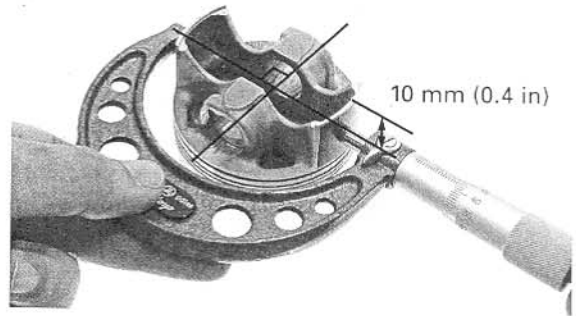

CONNECTING ROD INSPECTION

Measure the connecting rod small end I.D.

SERVICE LIMIT: 16.050 mm (0.6319 in)

Calculate the connecting rod-to-piston pin clearance.

SERVICE LIMIT: 0.070 mm (0.0028 in)

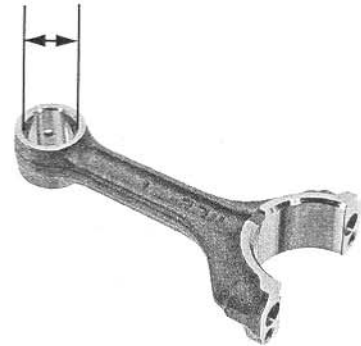

CYLINDER INSPECTION

Inspect the cylinder bore for wear or damage. Measure the cylinder I.D. in X and Y axis at three levels. Take the maximum reading to determine the cylinder wear.

SERVICE LIMIT: 67.10 mm (2.642 in)

Calculate the piston-to-cylinder clearance. Take a maximum reading to determine the clearance. Refer to the procedures for measurement of the piston O.D. (page 13-16).

SERVICE LIMIT: 0.10 mm (0.004 in)

Calculate the taper and out-of-round at three levels in X and Y axis. Take the maximum reading to determine them.

SERVICE LIMITS:

Taper: 0.10 mm (0.004 in)

Out-of-round: 0.10 mm (0.004 in)

The cylinder must be rebored and an oversize piston fitted if the service limits are exceeded.

The following oversize piston is available:

0.25 mm (0.010 in)

The piston to cylinder clearance for the oversize piston must be: 0.015 – 0.050 mm (0.0006 – 0.0020 in).

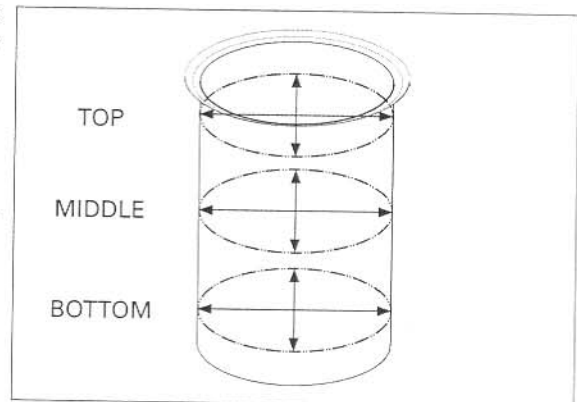
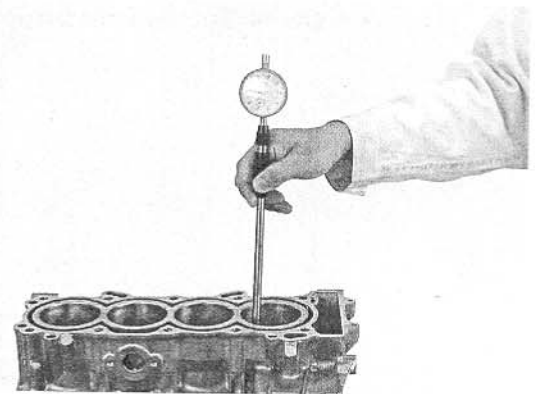

Inspect the top of the cylinder for warpage.

SERVICE LIMIT: 0.10 mm (0.004 in)

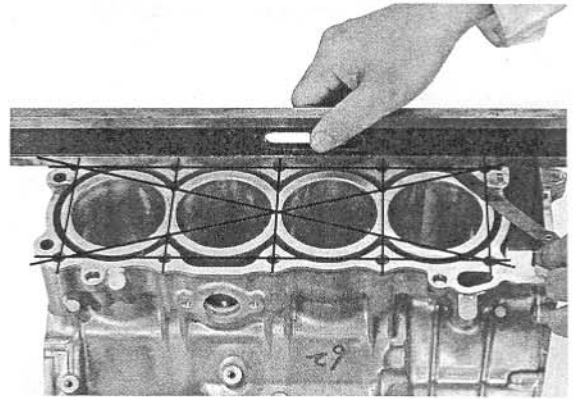

PISTON ASSEMBLY

Clean the piston ring grooves thoroughly and install the piston rings.

- Apply oil to the piston rings.
- Avoid piston and piston ring damage during installation.
- Install the piston rings with the marking (R: top ring, RN: second ring) facing up.
- Do not mix the top and second rings; top ring is narrower than the second ring in width.
- To install the oil ring, install the spacer first, then install the side rails.

Stagger the piston ring end gaps 120° apart from each other.
Stagger the side rail end gaps as shown.

After installation, the rings should rotate freely in the ring groove.

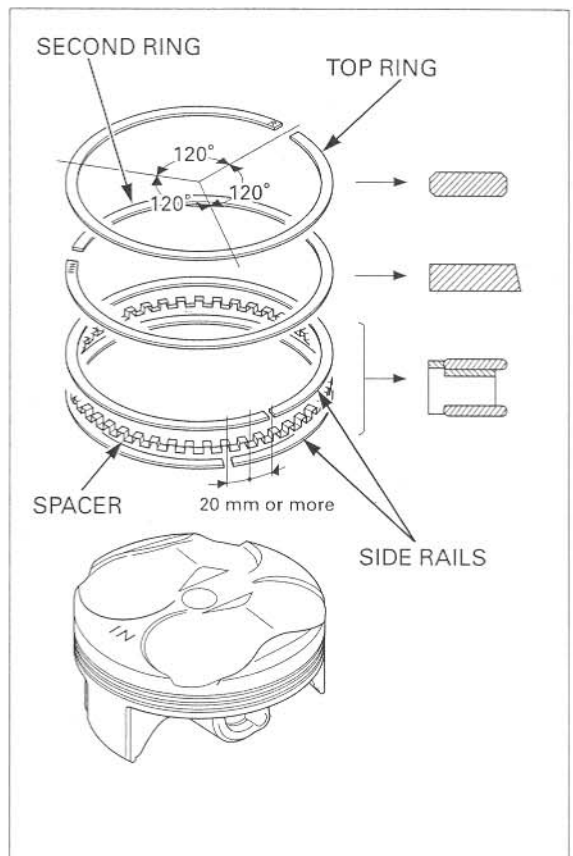

PISTON INSTALLATION

Apply molybdenum oil solution to the connecting rod small end inner surfaces and piston pin outer surfaces.

Assemble the piston and connecting rod with the journal bearing tab facing to the piston "IN" mark.

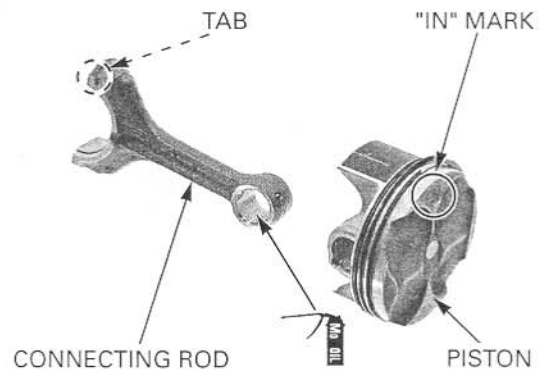

CRANKSHAFT/PISTON/CYLINDER

Install the piston pin and secure it using new piston pin clips.

- Make sure that the piston pin clips are seated securely.
- Do not align the piston pin clip end gap with the piston cut-out.

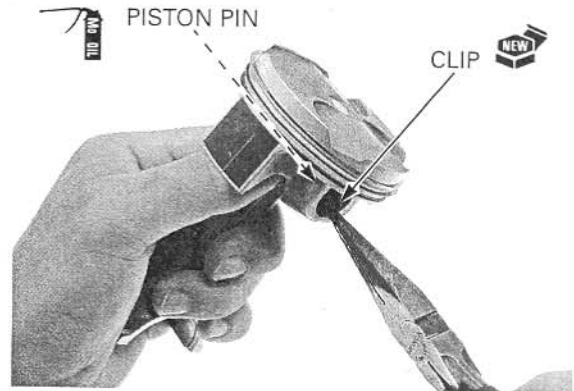

Coat the cylinder walls, pistons and piston rings with engine oil.

Install the piston/connecting rod assembly with the piston "IN" mark facing the intake side.

Install the piston/connecting rod assemblies into the cylinders using a commercially available piston ring compressor tool.

When reusing the connecting rods, they must be installed in their original locations.

NOTICE

- While installing the piston, be careful not to damage the top surface of the cylinder, especially around the cylinder bore.
- Be careful not to damage the cylinder sleeve and crankpin with the connecting rod.

Make sure the piston ring compressor tool sits flush on the top surface of the cylinder.

Use the handle of a plastic hammer or equivalent tool to tap the piston into the cylinder.

Install the crankshaft (page 13-6).

Apply molybdenum oil solution to the crankpin bearing sliding surface on the bearing caps.

Install the connecting rod bearing caps, aligning the dowel pins with the holes in the connecting rods.

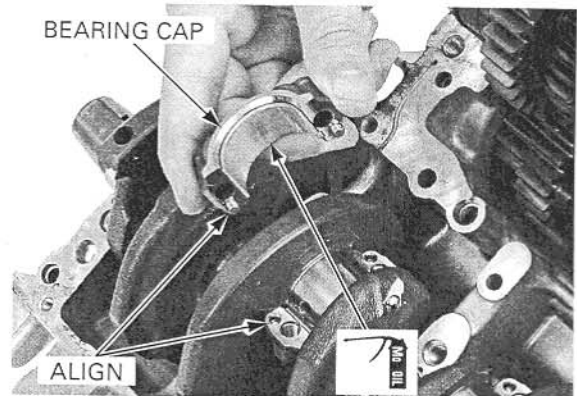
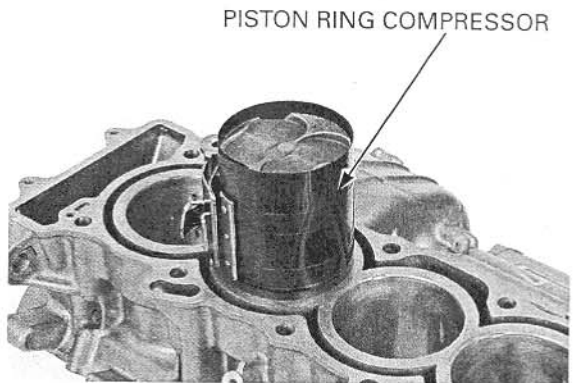

The connecting rod bolts cannot be reused. Once the connecting rod bolts have been loosened replace them with new ones.

Apply oil to new connecting rod bearing cap bolt threads and seating surfaces, and install the bolts.

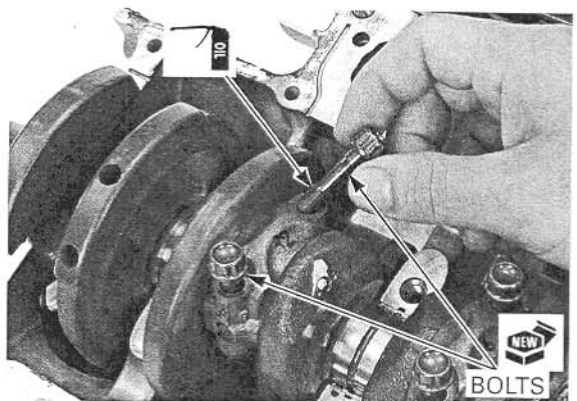

CRANKSHAFT/PISTON/CYLINDER

Tighten the bolts in two or three steps alternately.

Further tighten the bolts 90 degree.

TORQUE: 14 N·m (1.4 kgf·m, 10 lbf·ft) + 90°

Assemble the crankcase halves (page 12-16).

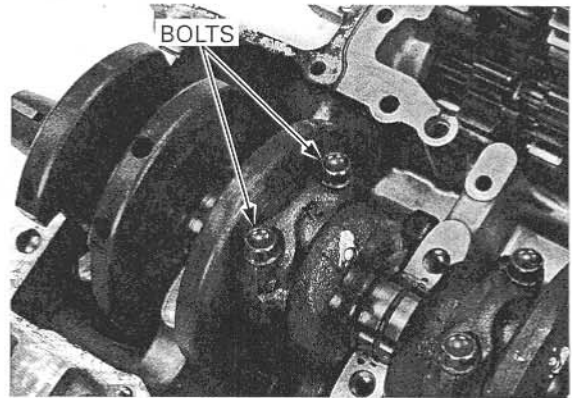

14. FRONT WHEEL/SUSPENSION/STEERING

COMPONENT LOCATION.....	14-2	FRONT WHEEL	14-12
SERVICE INFORMATION	14-3	FORK	14-18
TROUBLESHOOTING	14-6	STEERING STEM.....	14-27
HANDLEBARS.....	14-7		

FRONT WHEEL/SUSPENSION/STEERING

COMPONENT LOCATION

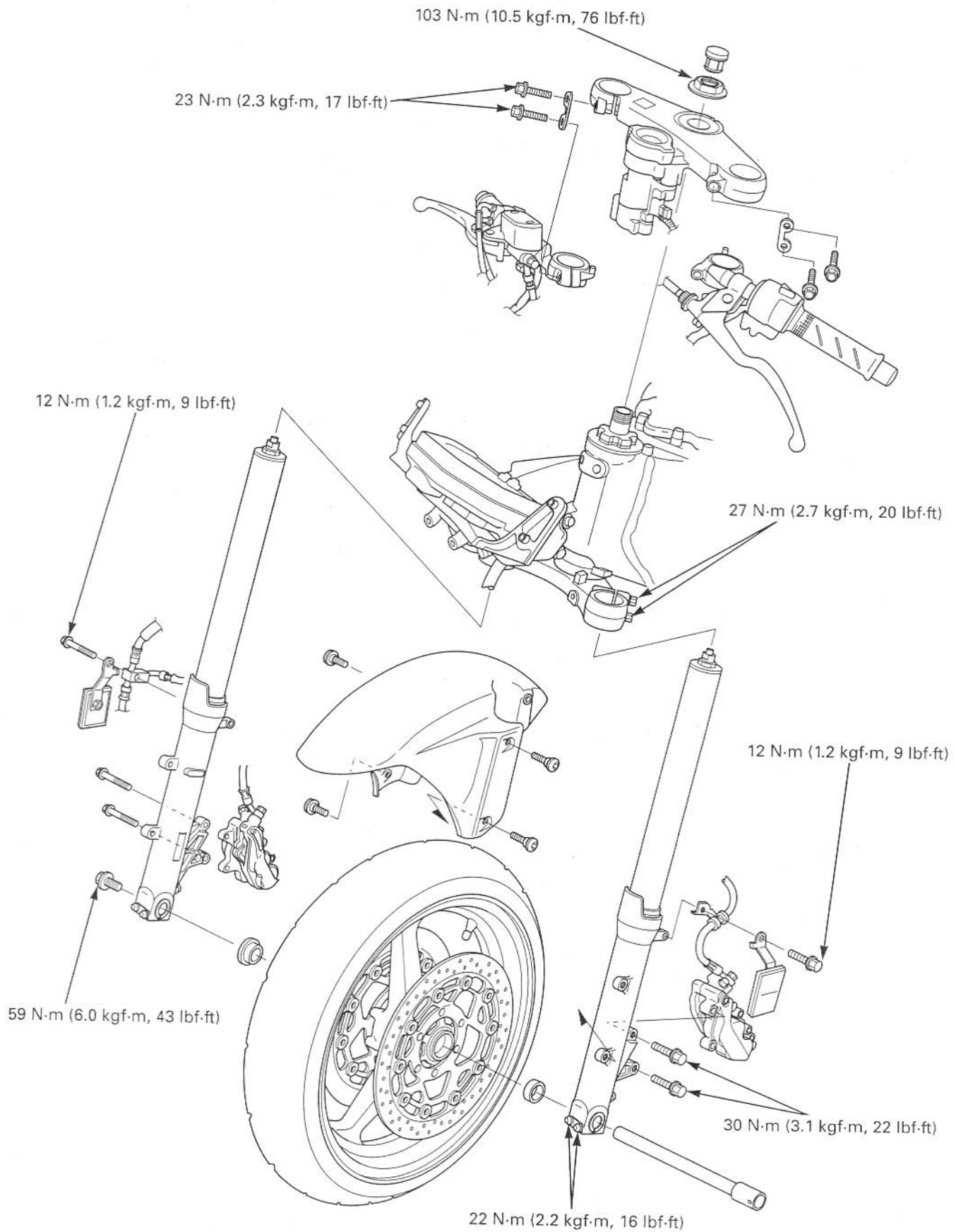

SERVICE INFORMATION

GENERAL

- When servicing the front wheel, fork or steering stem, support the motorcycle using a safety stand or hoist.
- A contaminated brake disc or pad reduces stopping power. Discard contaminated pads and clean a contaminated disc with a high quality brake degreasing agent.
- After the front wheel installation, check the brake operation by applying the brake lever.
- Refer to the brake system information (page 16-4).
- Use only tires marked "TUBELESS" and tubeless valves on rim marked "TUBELESS TIRE APPLICABLE".

SPECIFICATIONS

Unit: mm (in)

ITEM		STANDARD	SERVICE LIMIT
Minimum tire tread depth		–	1.5 (0.06)
Cold tire pressure	Driver only	250 kPa (2.50 kgf/cm ² , 36 psi)	–
	Driver and passenger	250 kPa (2.50 kgf/cm ² , 36 psi)	–
Axle runout		–	0.2 (0.01)
Wheel rim runout	Radial	–	2.0 (0.08)
	Axial	–	2.0 (0.08)
Wheel balance weight		–	60 g (2.1oz) max.
Fork	Spring free length	258.8 (10.19)	253.6 (9.98)
	Tube runout	–	0.20 (0.008)
	Recommended fork fluid	Pro Honda Suspension Fluid SS-8	–
	Fluid level	110 (4.3)	–
	Fluid capacity	531 ± 2.5 cm ³ (18.0 ± 0.08 US oz, 18.7 ± 0.09 Imp oz)	–
	Pre-load adjuster initial setting	14 mm (0.6 in) (4th groove from top)	–
	Rebound adjuster initial setting	2-1/2 turns out from full hard	–
	Compression adjuster initial setting	2 turns out from full hard	–
Steering head bearing pre-load		9.8 – 15 N·m (1.0 – 1.5 kgf·m)	–

TORQUE VALUES







Handlebar weight mounting screw	9.8 N·m (1.0 kgf·m, 7 lbf·ft)	ALOC screw; replace with a new one
Front brake disc bolt	20 N·m (2.0 kgf·m, 14 lbf·ft)	ALOC bolt; replace with a new one
Front axle bolt	59 N·m (6.0 kgf·m, 43 lbf·ft)	
Front axle holder pinch bolt	22 N·m (2.2 kgf·m, 16 lbf·ft)	
Fork socket bolt	34 N·m (3.5 kgf·m, 25 lbf·ft)	Apply a locking agent to the threads
Fork bolt	23 N·m (2.3 kgf·m, 17 lbf·ft)	
Fork top bridge pinch bolt	23 N·m (2.3 kgf·m, 17 lbf·ft)	
Handlebar pinch bolt	23 N·m (2.3 kgf·m, 17 lbf·ft)	
Fork bottom bridge pinch bolt	27 N·m (2.7 kgf·m, 20 lbf·ft)	
Steering stem adjusting nut	47 N·m (4.8 kgf·m, 35 lbf·ft)	
Steering stem adjusting lock nut	–	
Steering stem nut	103 N·m (10.5 kgf·m, 76 lbf·ft)	See page 14-34
Front brake hose clamp bolt	12 N·m (1.2 kgf·m, 9 lbf·ft)	
Front brake hose 3-way joint bolt	12 N·m (1.2 kgf·m, 9 lbf·ft)	
Front master cylinder holder bolt	12 N·m (1.2 kgf·m, 9 lbf·ft)	
Front brake caliper mounting bolt	30 N·m (3.1 kgf·m, 22 lbf·ft)	ALOC bolt; replace with a new one

FRONT WHEEL/SUSPENSION/STEERING

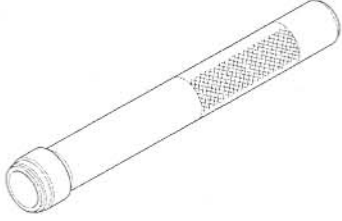
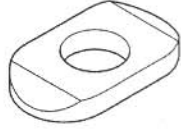
TOOLS

<p>Bearing remover shaft 07GGD-0010100</p> 	<p>Bearing remover head, 22 mm 07746-0050700</p> 	<p>Driver 07749-0010000</p> 
<p>Attachment, 42 x 47 mm 07746-0010300</p> 	<p>Pilot, 22 mm 07746-0041000</p> 	<p>Fork seal driver, 45 mm I.D. 07KMD-KZ30100</p>  <p>or 07KMD-KZ3010A (U.S.A. only)</p>
<p>Steering stem socket 07916-3710101</p>  <p>or 07916-3710100 (U.S.A. only)</p>	<p>Driver attachment, A 070MF-MCJ0100</p>  <p>Not available in U.S.A.</p>	<p>Driver attachment, B 070MF-MCJ0200</p>  <p>Not available in U.S.A.</p>
<p>Driver shaft assembly 07946-KM90301</p>  <p>Not available in U.S.A.</p>	<p>Bearing remover, A 07946-KM90401</p>  <p>Not available in U.S.A.</p>	<p>Bearing remover, B 07NMF-MT70110</p>  <p>Not available in U.S.A.</p>

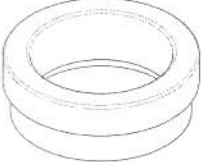
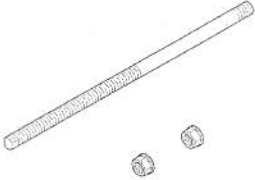
FRONT WHEEL/SUSPENSION/STEERING

<p>Assembly base 07946-KM90600</p>  <p>Not available in U.S.A.</p>	<p>Steering stem driver 07946-MB00000</p> 	<p>Remover attachment, C 07AMF-MEEA100</p> 
<p>Remover attachment, D 07AMF-MEEA200</p> 	<p>Main bearing driver attachment 07946-ME90200</p> 	<p>Fork seal driver weight 07947-KA50100</p> 
<p>Oil seal driver 07965-MA60000</p> 	<p>Installer shaft 07VMF-KZ30200</p> 	<p>Installer attachment, A 07VMF-MAT0100</p> 
<p>Installer attachment, B 07VMF-MAT0200</p> 		

FRONT WHEEL/SUSPENSION/STEERING

TROUBLESHOOTING

Hard steering

- Steering head bearing adjusting nut too tight
- Worn or damaged steering head bearings
- Bent steering stem
- Insufficient tire pressure

Steers to one side or does not track straight

- Damaged or loose steering head bearings
- Bent forks
- Bent axle
- Bent frame
- Worn or damaged wheel bearings
- Worn or damaged swingarm pivot bearings

Front wheel wobbling

- Bent rim
- Worn or damaged front wheel bearings
- Faulty tire
- Unbalanced front tire and wheel

Front wheel turns hard

- Faulty front wheel bearings
- Bent front axle
- Front brake drag

Soft suspension

- Insufficient fluid in fork
- Incorrect fork fluid weight
- Weak fork springs
- Insufficient tire pressure

Hard suspension

- Bent fork tubes
- Too much fluid in fork
- Incorrect fork fluid weight
- Clogged fork fluid passage

Front suspension noise

- Insufficient fluid in fork
- Loose fork fasteners

HANDLEBARS

REMOVAL

Remove the screw and right handlebar weight.

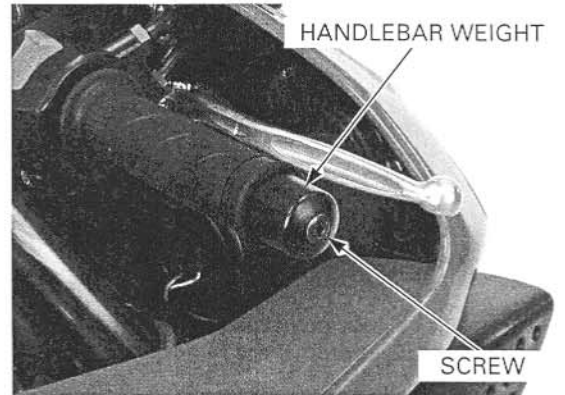

Disconnect the front brake switch wire connectors from the switch.

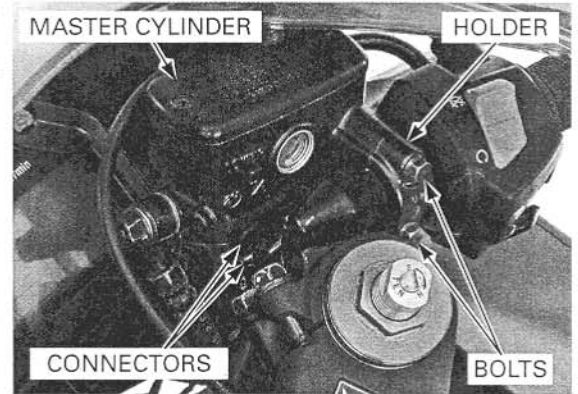

Remove the master cylinder holder bolts, holder and master cylinder assembly.

Keep the brake master cylinder upright to prevent air from entering the hydraulic system.

Remove the right handlebar switch/throttle housing screws.

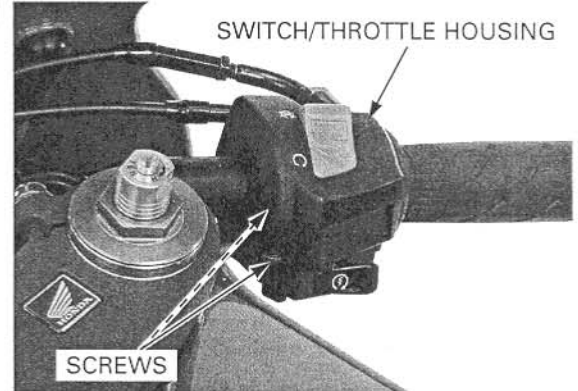

Disconnect the throttle cables from the throttle pipe and remove the throttle grip from the right handlebar.

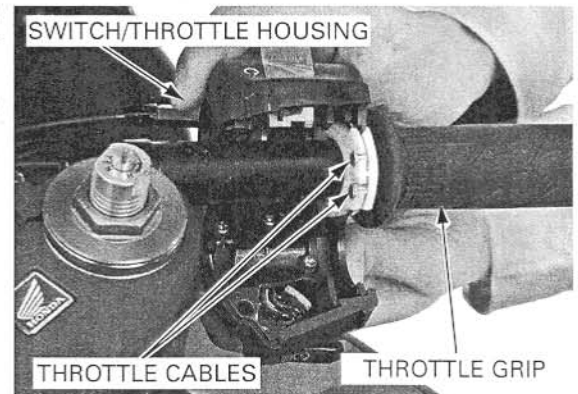

Remove the right handlebar switch/throttle housing from the right handlebar.

FRONT WHEEL/SUSPENSION/STEERING

Remove the screws and left handlebar switch housing.

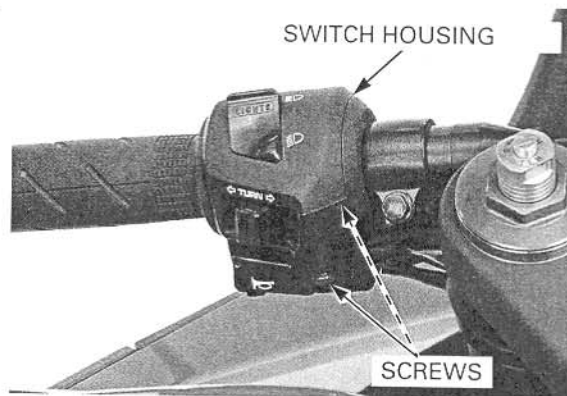

Remove the screw and left handlebar weight. Remove the handle grip from the handlebar.

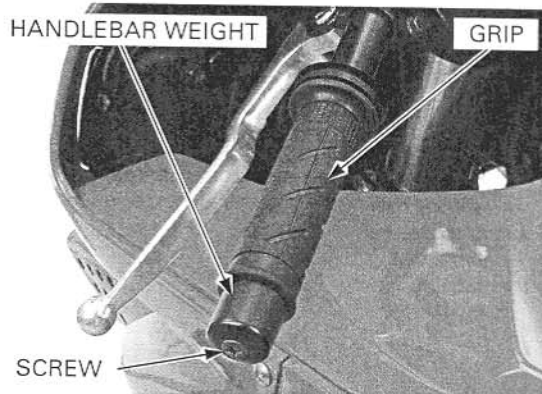

Loosen the clutch lever bracket pinch bolt. Disconnect the clutch switch connectors from the clutch switch.

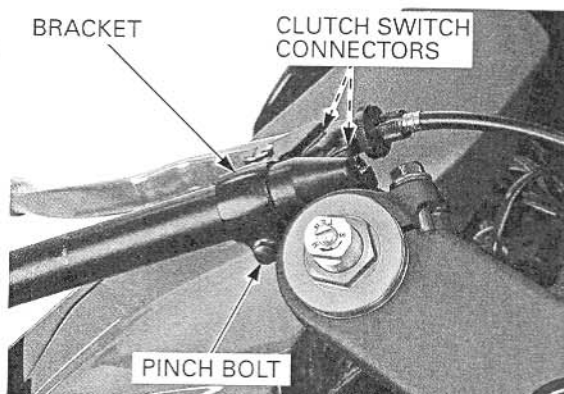

Remove the steering stem cap, top bridge pinch bolts, handlebar pinch bolts and setting plates.

Remove the steering stem nut and top bridge.

Remove the handlebars from the fork tube.

Remove the clutch lever bracket from the left handlebar.

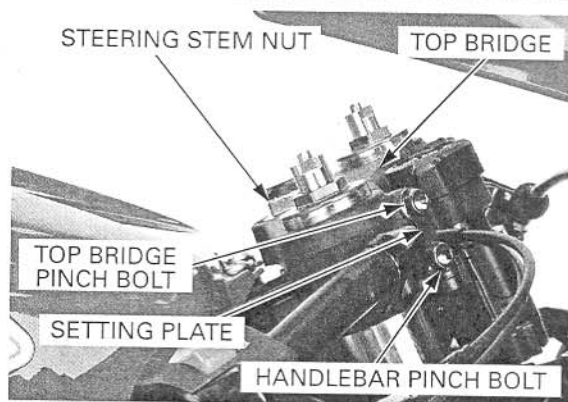

FRONT WHEEL/SUSPENSION/STEERING

INSTALLATION

Apply grease to the sliding surface of the throttle pipe.

Install the clutch lever bracket to the left handlebar, and also the throttle pipe to the right handlebar.

Install the handlebars onto the fork tube.

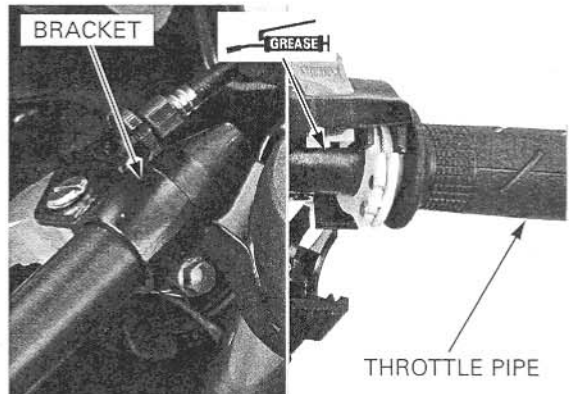

Install the top bridge while aligning its holes with the handlebar stopper pins.

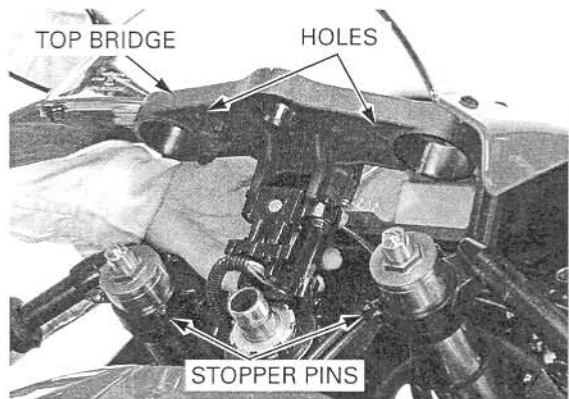

Tighten the steering stem nut to the specified torque.

TORQUE: 103 N·m (10.5 kgf·m, 76 lbf·ft)

Install the steering stem cap.

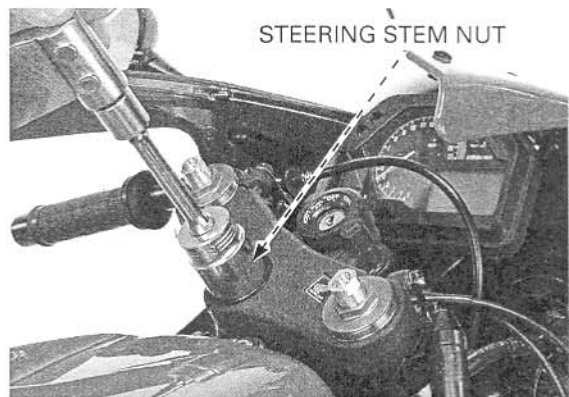

Install the setting plates, top bridge pinch bolts and handlebar pinch bolts.

Tighten the top bridge pinch bolts to the specified torque.

TORQUE: 23 N·m (2.3 kgf·m, 17 lbf·ft)

Tighten the handlebar pinch bolts to the specified torque.

TORQUE: 23 N·m (2.3 kgf·m, 17 lbf·ft)

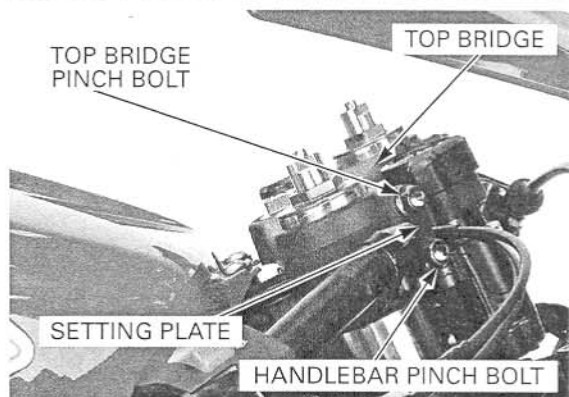

FRONT WHEEL/SUSPENSION/STEERING

HANDLEBAR WEIGHT REPLACEMENT

Remove the grip from the handlebar.
Straighten the weight retainer tab by the screwdriver or punch.

Apply lubricant spray through the tab locking hole to the rubber for easy removal.

Temporarily install the handlebar weight and screw, then remove the inner weight by turning the handlebar weight.

Remove the handlebar weight from the inner weight.
Discard the retainer ring.

Install the new retainer ring onto the inner weight.
Install the handlebar weight onto the inner weight while aligning the bosses and grooves each other.
Install a new mounting screw.

Insert the handlebar weight assembly into the handlebar.
Turn the handlebar weight and hook the retainer ring tab with the hole in the handlebar.

Apply Honda Bond A or equivalent adhesive to the inside of the grip and to the clean surfaces of the left handlebar and throttle grip.

Wait 3 – 5 minutes and install the grip.

Rotate the grip for even application of the adhesive.

Allow the adhesive to dry for an hour before using.

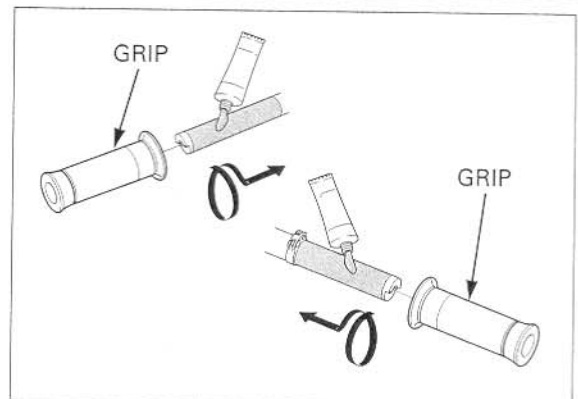
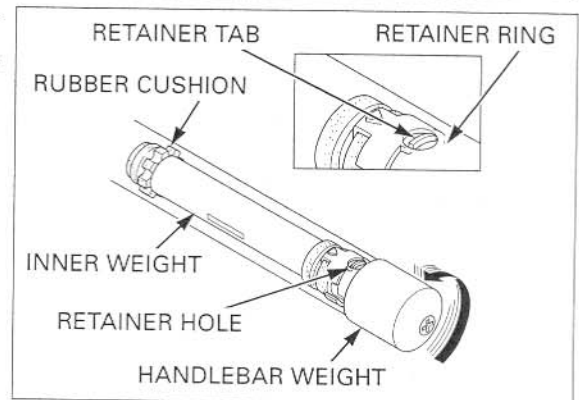
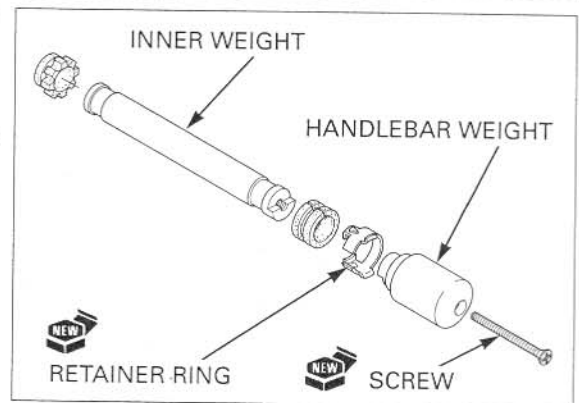
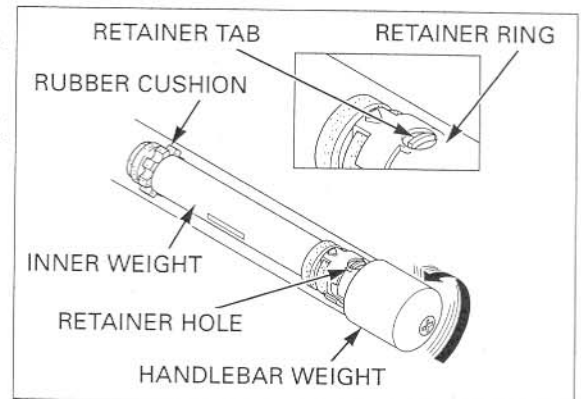

FRONT WHEEL/SUSPENSION/STEERING

Tighten the clutch lever bracket pinch bolt, aligning the punch mark on the left handlebar and clutch lever bracket.

Connect the clutch switch connector.

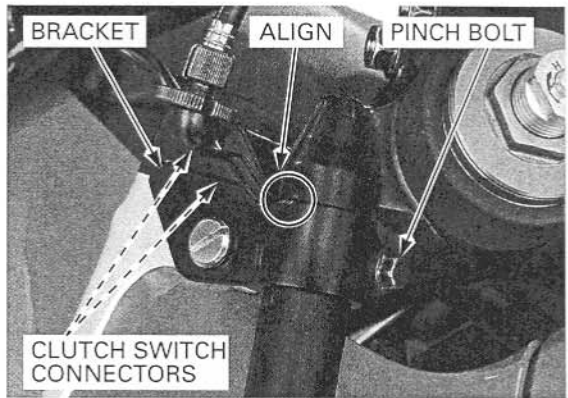

Install the left handlebar switch housing aligning its locating pin with the hole in the handlebar.

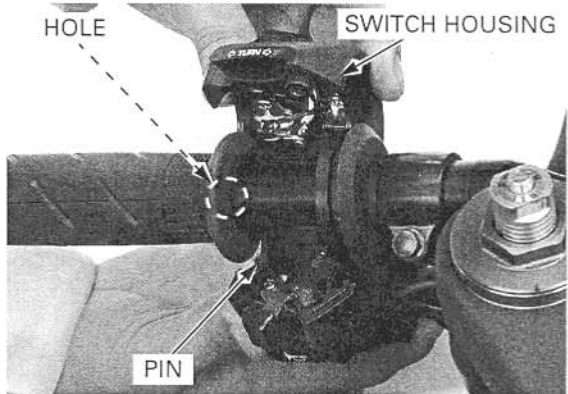

Tighten the forward screw first, then the rear screw.

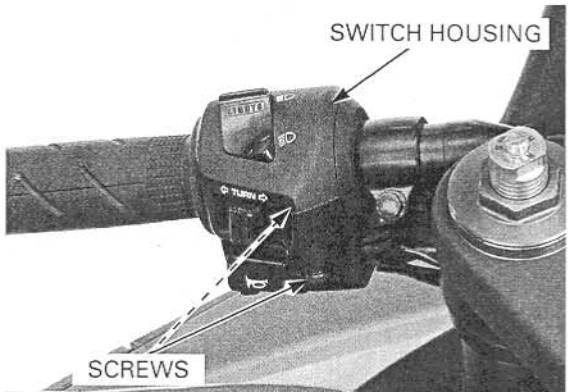

Connect the throttle cables into the throttle pipe.

Install the right handlebar switch/throttle housing by aligning its locating pin with the hole in the handlebar.

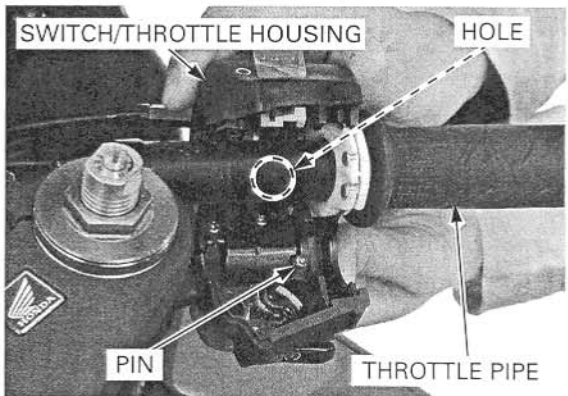

FRONT WHEEL/SUSPENSION/STEERING

Tighten the forward screw first, then the rear screw.

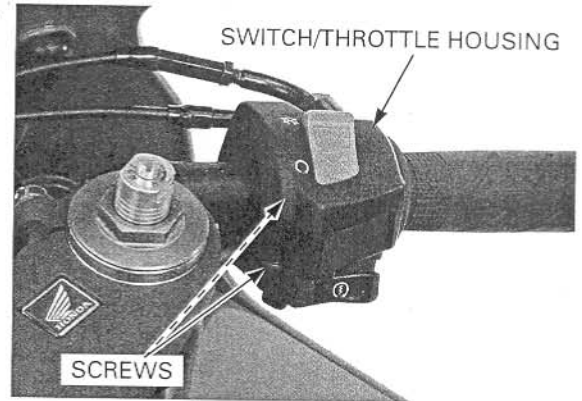

Install the master cylinder by aligning the end of the master cylinder with the punch mark on the handlebar. Install the master cylinder holder with its "UP" mark facing up. Tighten the upper bolt first, then the lower bolt.

TORQUE: 12 N·m (1.2 kgf·m, 9 lbf·ft)

Connect the front brake switch wire connectors.

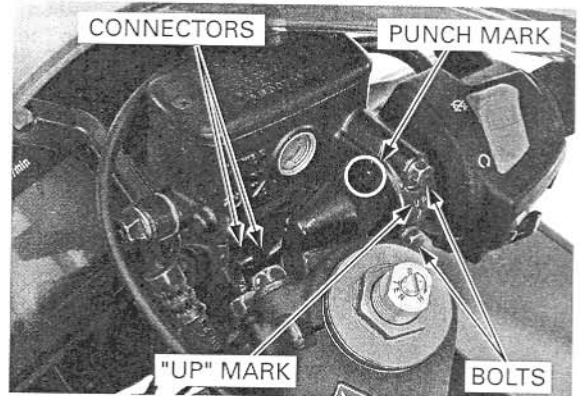

Install the handlebar weights on both handlebars and tighten the new mounting screws to the specified torque.

TORQUE: 9.8 N·m (1.0 kgf·m, 7 lbf·ft)

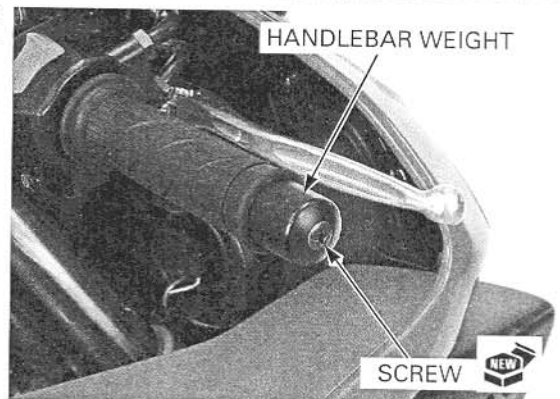

FRONT WHEEL

REMOVAL

Support the motorcycle securely and raise the front wheel off the ground using a safety stand or a hoist.

Remove the brake caliper mounting bolts and both brake calipers.

Do not operate the brake lever after the brake caliper is removed.

Support the brake caliper with a piece of wire so that it does not hang from the brake hose. Do not twist the brake hose.

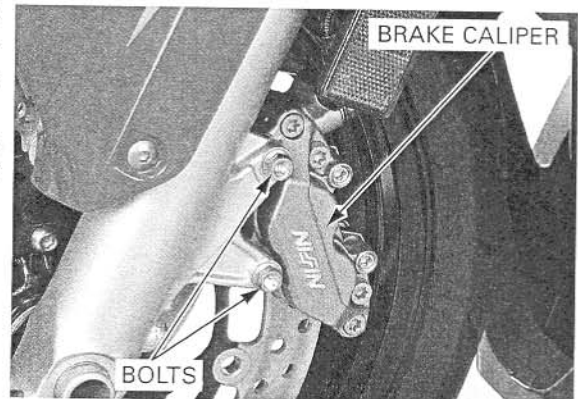

FRONT WHEEL/SUSPENSION/STEERING

Loosen the right axle pinch bolts.
Remove the axle bolt.

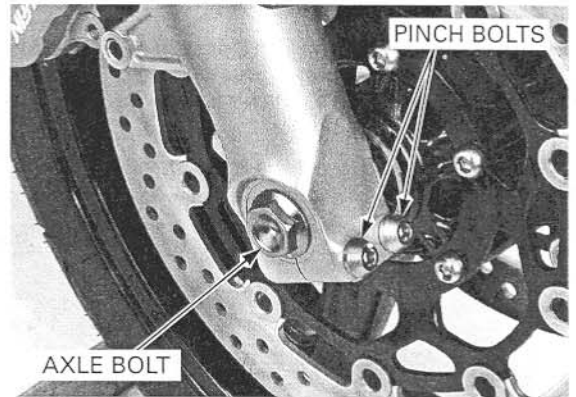

Loosen the left axle pinch bolts.
Remove the axle and front wheel.

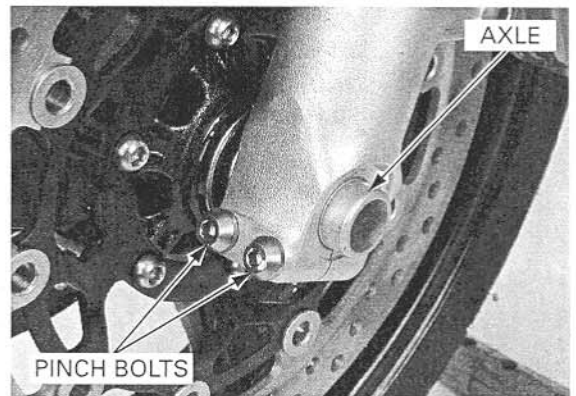

Remove the side collars.

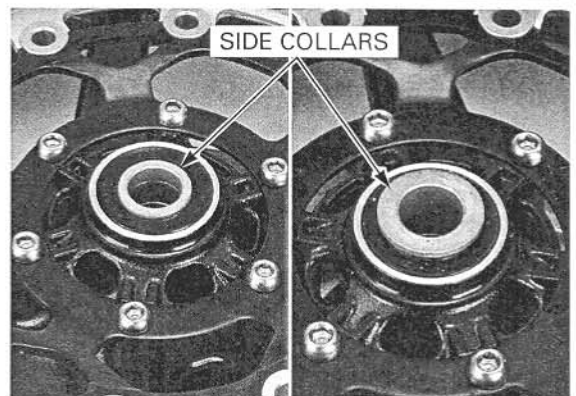

INSPECTION

Axle

Set the axle on V-blocks and measure the runout.
Actual runout is 1/2 the total indicator reading.

SERVICE LIMIT: 0.2 mm (0.008 in)

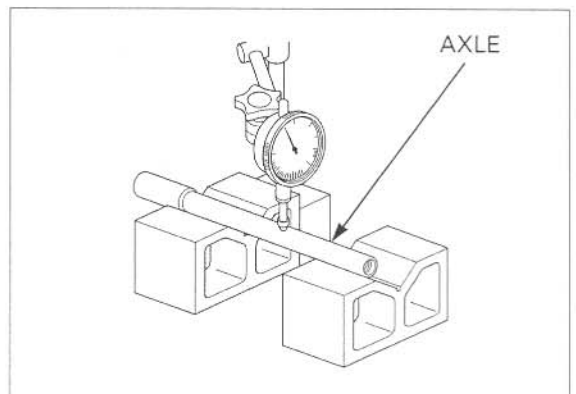

FRONT WHEEL/SUSPENSION/STEERING

Wheel bearing

Turn the inner race of each bearing with your finger. The bearings should turn smoothly and quietly. Also check that the bearing outer race fits tightly in the hub.

Replace the bearings in pairs.

Remove and discard the bearings if they do not turn smoothly, quietly, or if they fit loosely in the hub.

Replace the wheel bearings, if necessary (page 14-15).

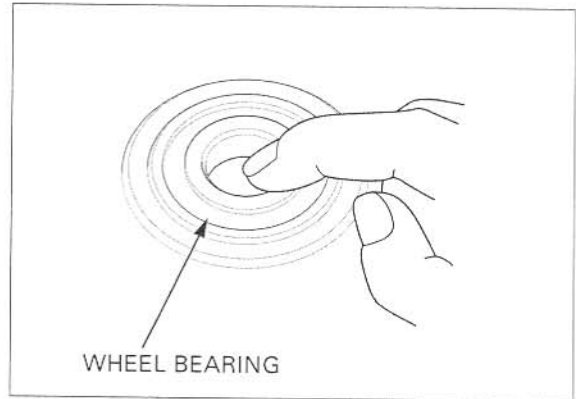

Wheel rim runout

Check the rim runout by placing the wheel in a turning stand.

Spin the wheel by hand, and read the runout using a dial indicator.

Actual runout is 1/2 the total indicator reading.

SERVICE LIMITS:

Radial: 2.0 mm (0.08 in)

Axial: 2.0 mm (0.08 in)

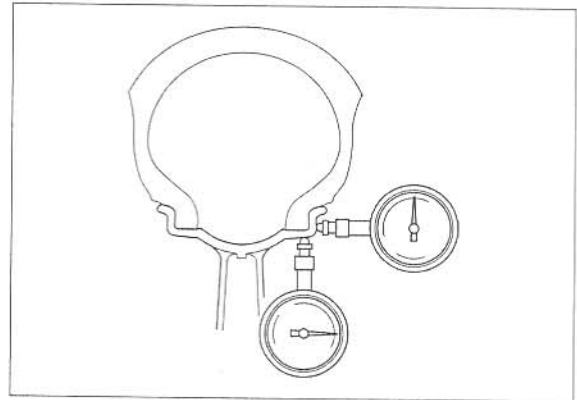

For optimum balance, the tire balance mark (a paint dot on the side wall) must be located next to the valve stem. Remount the tire if necessary.

Wheel balance

- Wheel balance directly affects the stability, handling and over all safety of the motorcycle. Always check balance when the tire has been removed from the rim.

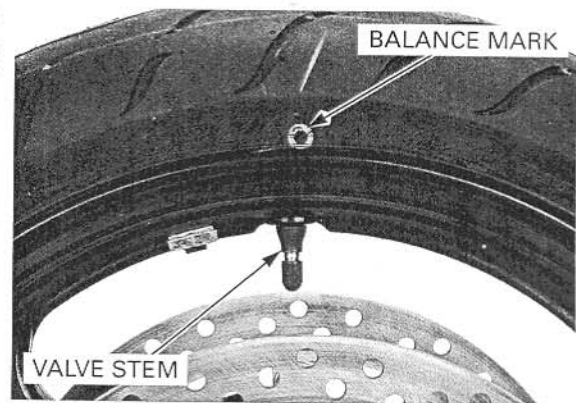

Note the rotating direction marks on the wheel and tire.

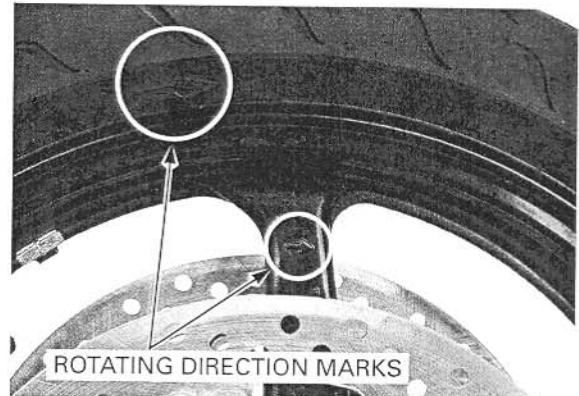

FRONT WHEEL/SUSPENSION/STEERING

Remove the dust seals from the wheel.
Mount the wheel, tire and brake discs assembly in an inspection stand.
Spin the wheel, allow it to stop, and mark the lowest (heaviest) point of the wheel with a chalk.
Do this two or three times to verify the heaviest area.
If the wheel is balanced, it will not stop consistently in the same position.

To balance the wheel, install the wheel weights on the highest side of the rim, the side opposite the chalk marks. Add just enough weight so the wheel will no longer stop in the same position when it is spun. Do not add more than 60 grams to the wheel.

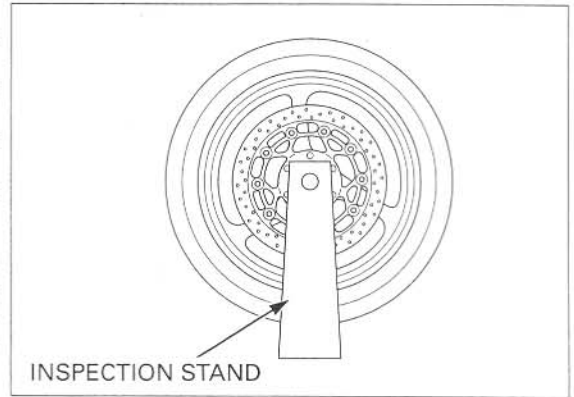

DISASSEMBLY

Remove the bolts and brake discs.
Remove the dust seals.

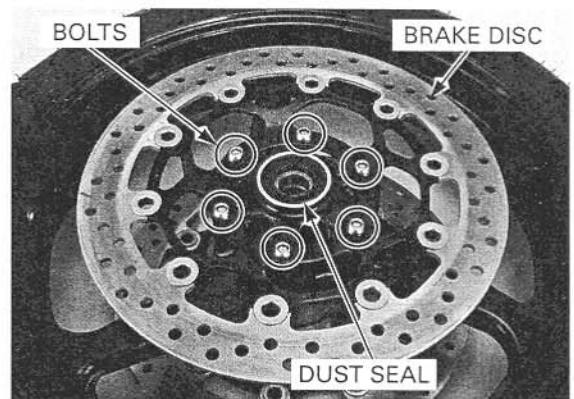

Install the bearing remover head into the bearing.
From the opposite side, install the bearing remover shaft and drive the bearing out of the wheel hub.
Remove the distance collar and drive out the other bearing.

TOOLS:

Bearing remover head, 22 mm 07746-0050700

Bearing remover shaft 07GGD-0010100

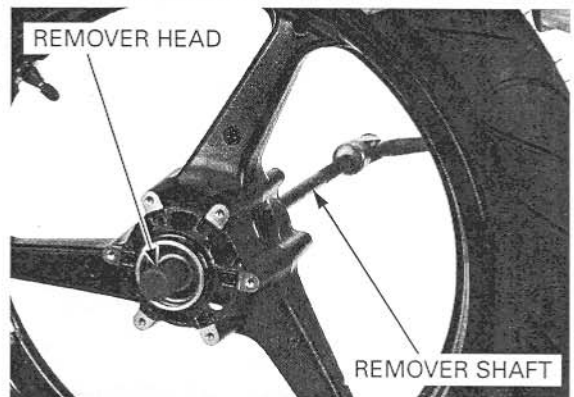

FRONT WHEEL/SUSPENSION/STEERING

ASSEMBLY

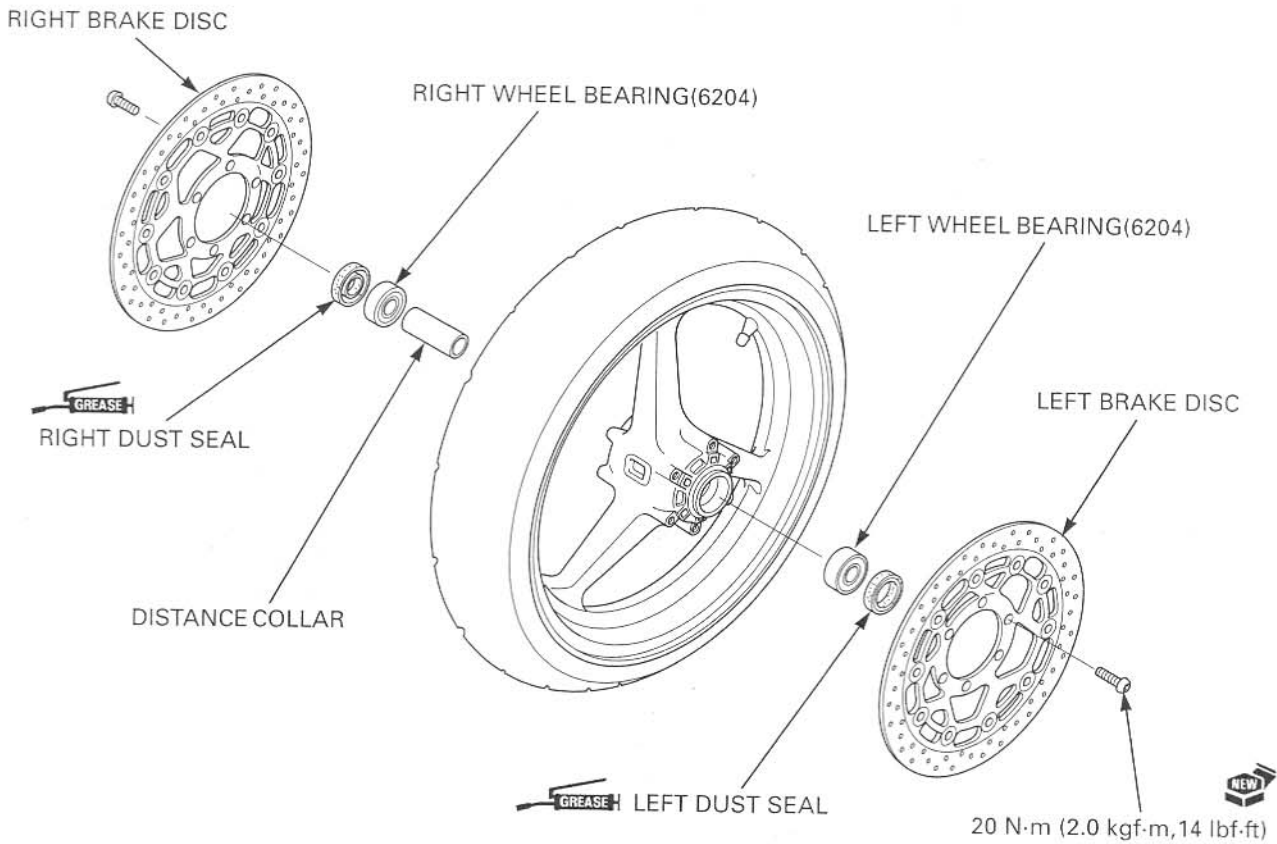

Never install the old bearings. Once the bearings has been removed, the bearings must be replaced with new ones.

Drive in a new right bearing squarely. Install the distance collar, then drive in the left bearing using the special tools.

TOOLS:

- | | |
|-------------------------------|---------------|
| Driver | 07749-0010000 |
| Attachment, 42 X 47 mm | 07746-0010300 |
| Pilot, 22 mm | 07746-0041000 |

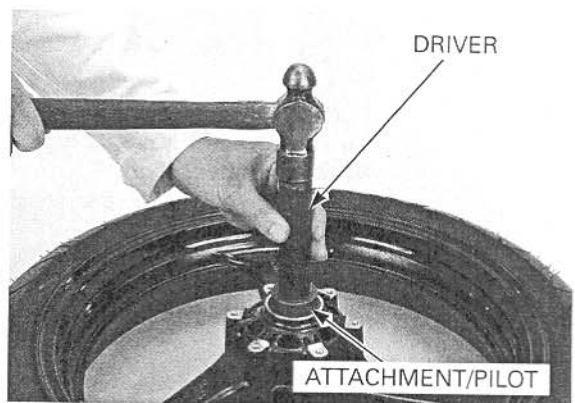

Do not get grease on the brake discs or stopping power will be reduced.

Install the brake discs with the arrow mark facing in the normal rotating direction. Install new disc bolts and tighten them in a criss-cross pattern in two or three steps.

TORQUE: 20 N·m (2.0 kgf·m, 14 lbf·ft)

Apply grease to the dust seal lips, then install them into the wheel hub.

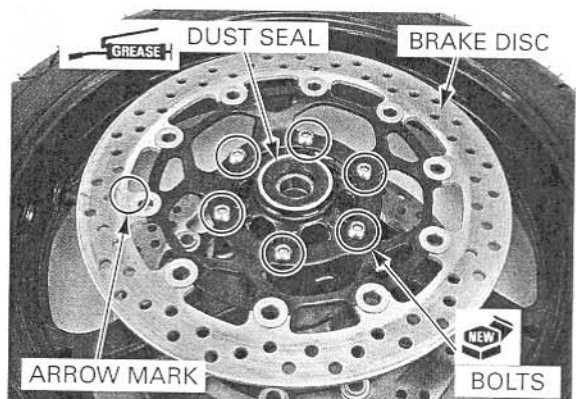

INSTALLATION

Install the right and left side collars.

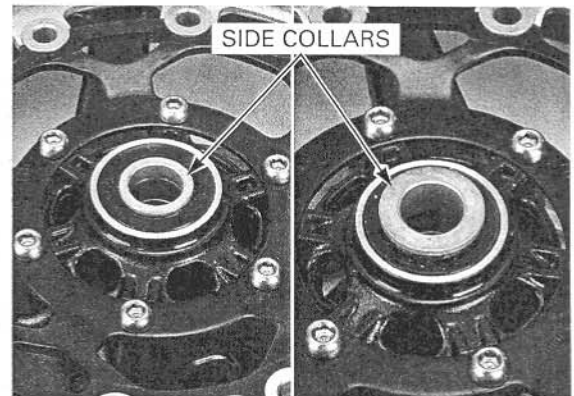

Install the front wheel between the fork legs.

Apply a thin layer of grease to the front axle surface.
Install the front axle from the left side.

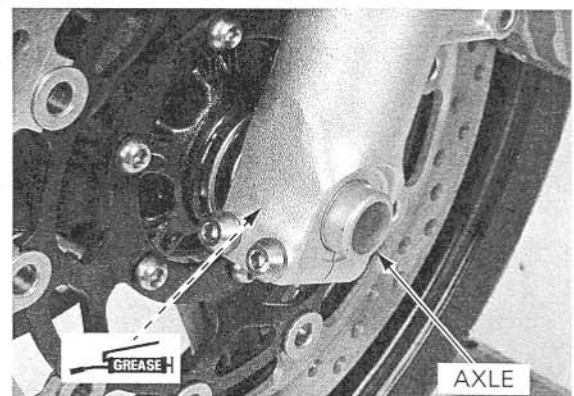

Hold the axle and tighten the axle bolt to the specified torque.

TORQUE: 59 N·m (6.0 kgf·m, 43 lbf·ft)

Tighten the right axle pinch bolts to the specified torque.

TORQUE: 22 N·m (2.2 kgf·m, 16 lbf·ft)

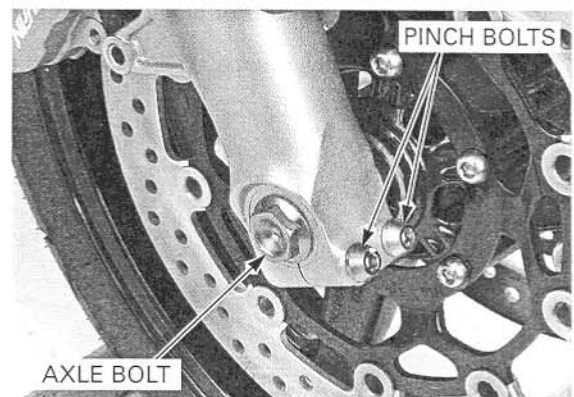

Install the both brake caliper and tighten the new mounting bolts to the specified torque.

TORQUE: 30 N·m (3.1 kgf·m, 22 lbf·ft)

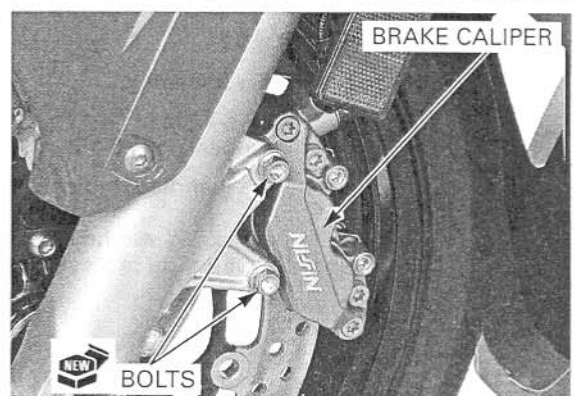

FRONT WHEEL/SUSPENSION/STEERING

With the front brake applied, pump the fork up and down several times to seat the axle and check brake operation.

Check the brake operation by applying the brake lever.



Tighten the left axle pinch bolts to the specified torque.

TORQUE: 22 N·m (2.2 kgf·m, 16 lbf·ft)

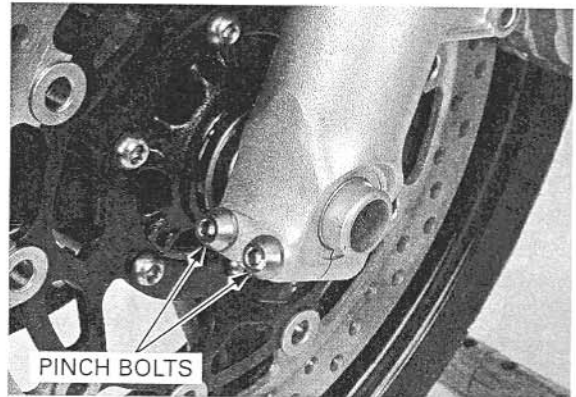

Check the clearance between the brake disc and caliper body (not brake pad) on each side after installation.

The clearance should be at least 0.7 mm (0.03 in).

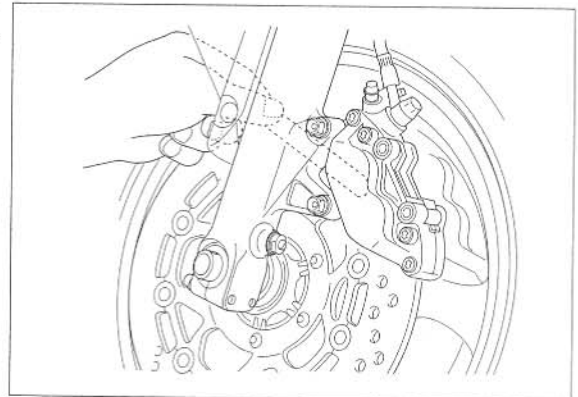

FORK

REMOVAL

Keep the brake master cylinder upright.

Remove the following:

- Front wheel (page 14-12)
- Front fender (page 3-15)

Loosen the handlebar pinch bolt and top bridge pinch bolt.

When the fork leg will be disassembled, loosen the fork bolt, but do not remove it yet.

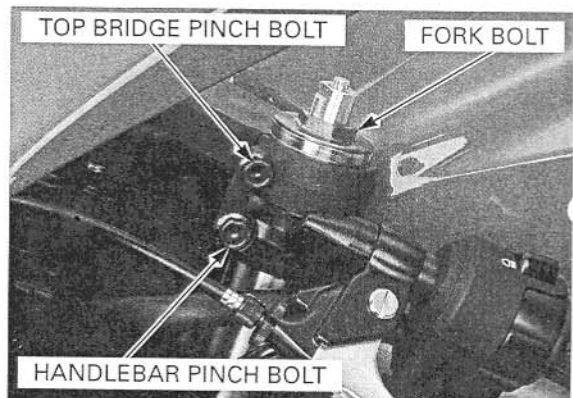

FRONT WHEEL/SUSPENSION/STEERING

Loosen the fork bottom pinch bolts and remove the fork tube from the fork top bridge and steering stem.

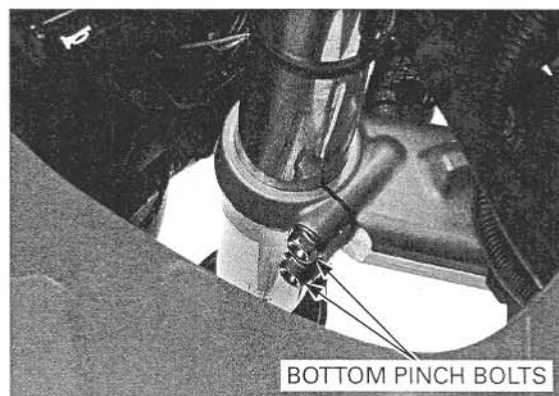

DISASSEMBLY

Be careful not to scratch the fork tube or damage the dust seal.

Remove the fork protector by prying it carefully using a screwdriver.

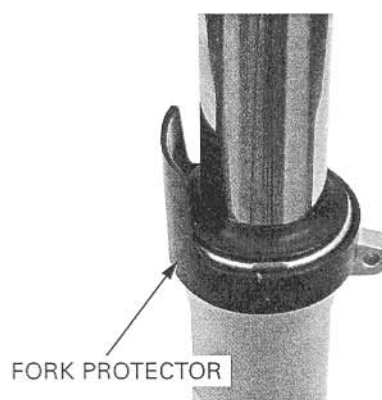

Remove the fork bolt from the fork tube.

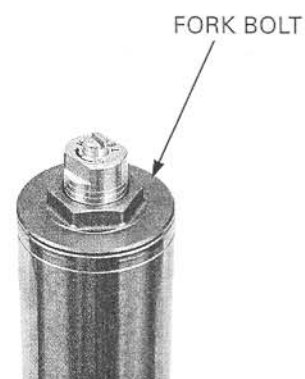

Push down the spring joint plate and install the 14 mm wrench onto the rebound adjuster.

Do not remove the rebound damping adjuster from the damper rod, or fork damping force will be changed.

Hold the rebound adjuster, then loosen and remove the fork bolt from the rebound adjuster.

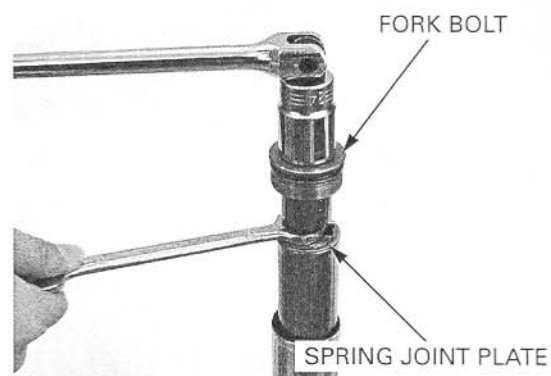

FRONT WHEEL/SUSPENSION/STEERING

Remove the following:

- Spring joint plate
- Spring collar
- Spring seats
- Fork spring

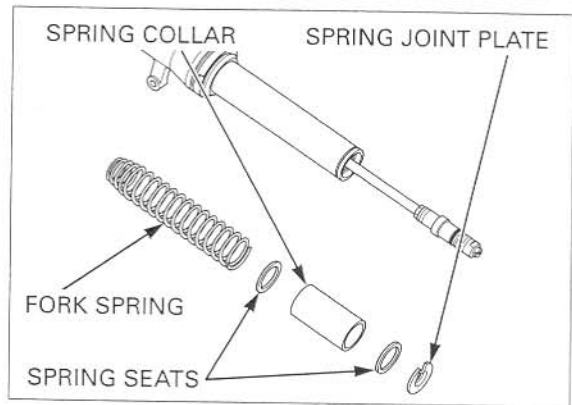

Pour out the fork fluid by pumping the fork tube several times.

Pour out the fork fluid from the fork damper by pumping the damper rod several times.

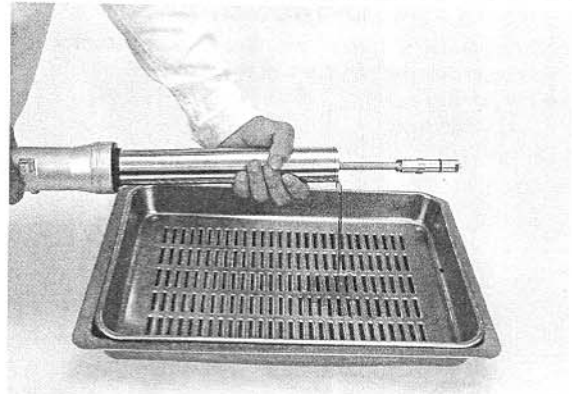

Hold the fork slider in a vice with soft jaws or a shop towel.

If the fork damper turns together with the socket bolt, temporarily install the fork spring, spring seats, collar, joint plate and fork bolt.

Remove the fork damper socket bolt and sealing washer.

SOCKET BOLT/SEALING WASHER

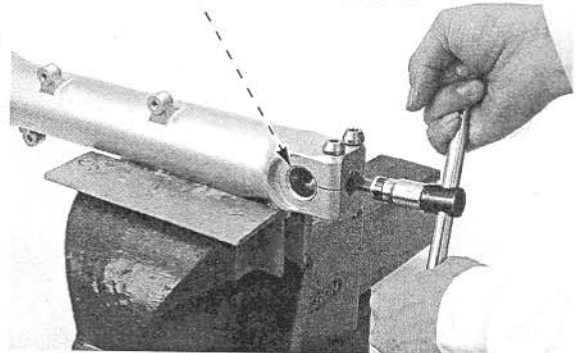

Remove the fork damper assembly from the fork tube.

FORK DAMPER

FORK TUBE

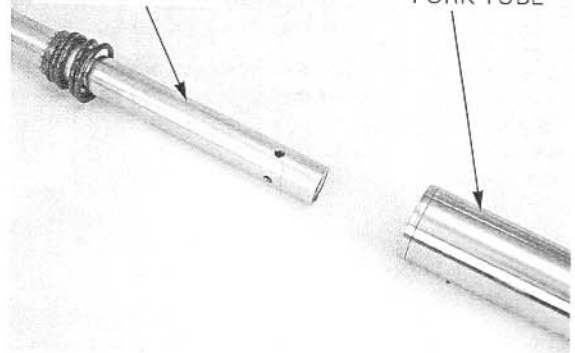

FRONT WHEEL/SUSPENSION/STEERING

Remove the dust seal.

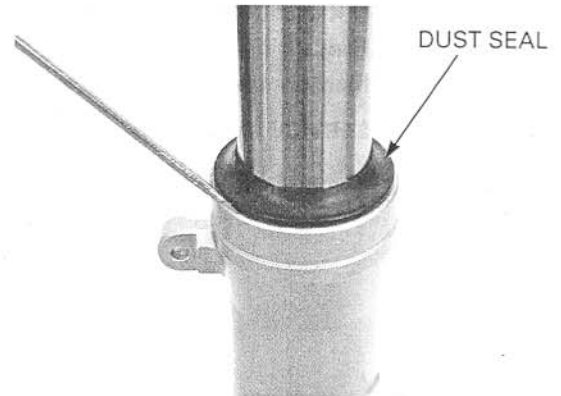

Do not scratch the fork tube sliding surface. Remove the oil seal stopper ring.

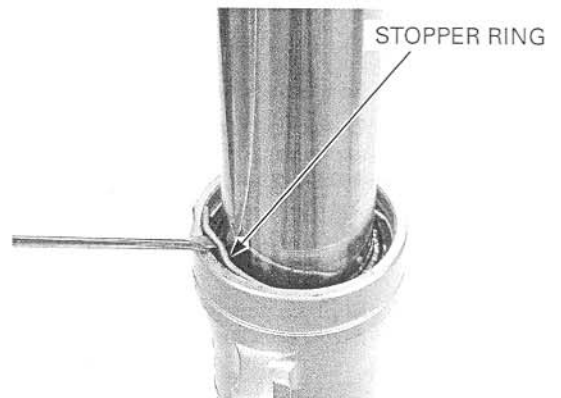

Pull the fork tube out until you feel resistance from the slider bushing. Then move it in and out, tapping the bushing lightly until the fork tube separates from the fork slider. The slider bushing will be forced out by the fork tube bushing.

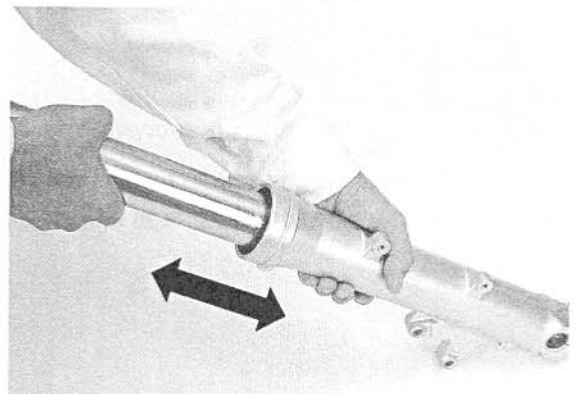

Remove the oil lock piece from the fork tube.
Remove the oil seal, back-up ring and slider bushing from the fork tube.

Do not remove the fork tube bushing unless it necessary to replace it with a new one. Carefully remove the fork tube bushing by prying the slit with a screwdriver until the bushing can be pulled off by hand.

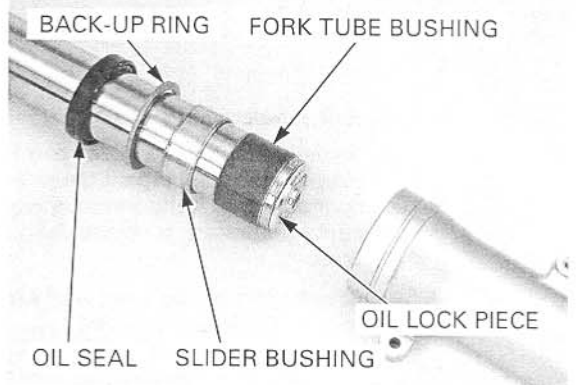

FRONT WHEEL/SUSPENSION/STEERING

INSPECTION

Fork spring

Measure the fork spring free length.

SERVICE LIMIT: 253.6 mm (9.98 in)

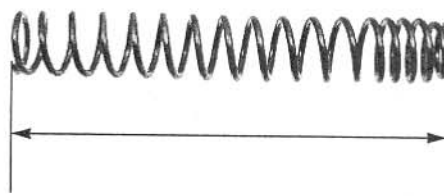

fork tube/slider/damper

Check the fork tube and fork slider for score marks, scratches, or excessive or abnormal wear. Replace any components which are worn or damaged.

Check the fork damper for damage. Check the oil lock piece for wear or damage.

Replace the fork damper assembly, if any components are damaged.

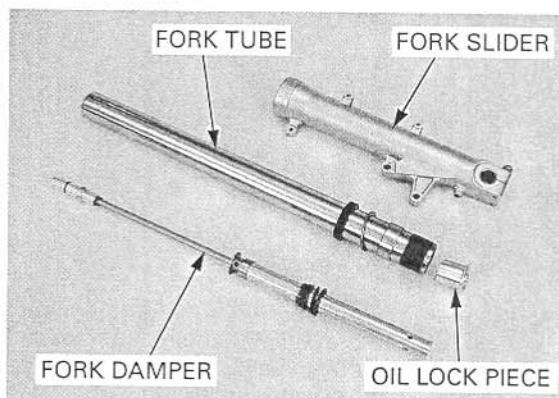

Place the fork tube on V-blocks and measure the runout.

Actual runout is 1/2 the total indicator reading.

SERVICE LIMIT: 0.20 mm (0.008 in)

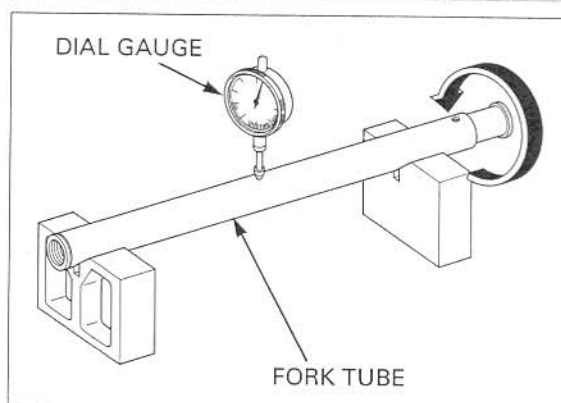

fork tube bushing

Visually inspect the slider and fork tube bushings. Replace the bushings if there is excessive scoring or scratching, or if the teflon is worn so that the copper surface appears on more than 3/4 of the entire surface.

Check the back-up ring; replace it if there is any distortion at the points shown.

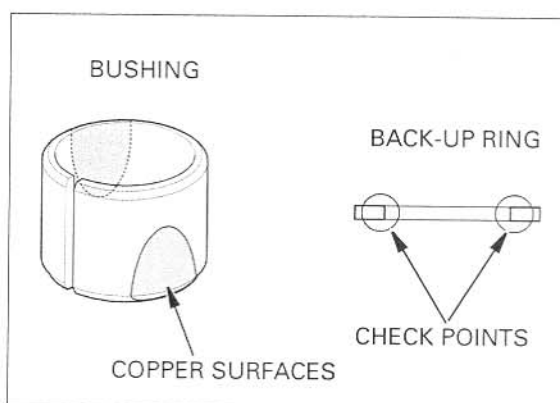

ASSEMBLY

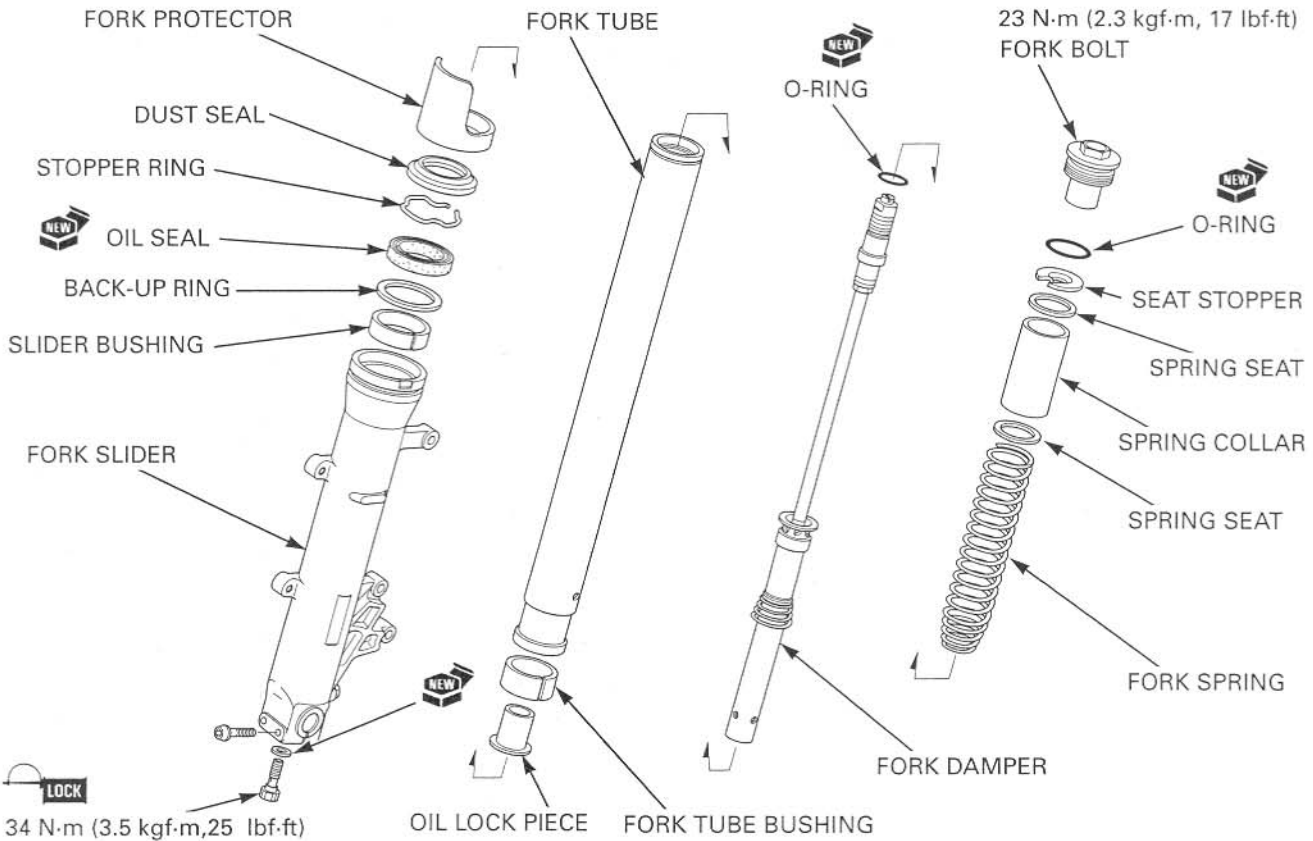

Before assembly, wash all parts with a high flash or non-flammable solvent and wipe them dry.

Do not open the bushing slit more than necessary.

Install the new fork tube bushing being careful not to damage the coating of the bushing if it has been removed.

Remove the burrs from the bushing mating surface, being careful not to peel off the coating.

Install the oil seal with its marked side facing up.

Install the slider bushing, back-up ring and new oil seal onto the fork tube.

Install the oil lock piece into the fork tube.

Apply fork fluid to the oil seal lips.
Install the fork tube into the fork slider.

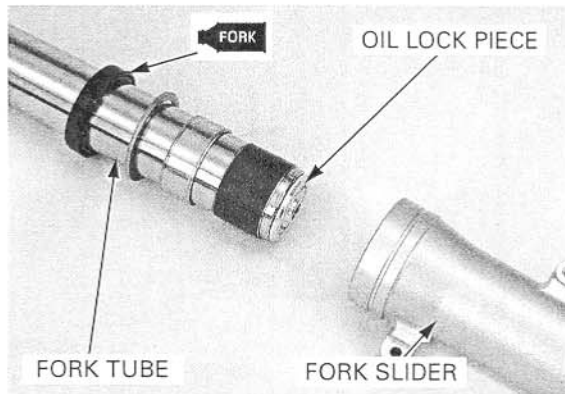
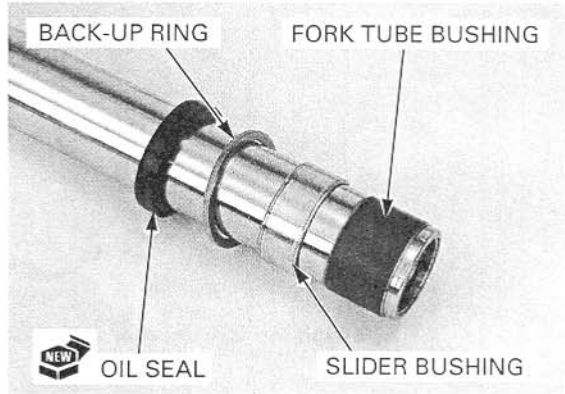

FRONT WHEEL/SUSPENSION/STEERING

Drive the oil seal in using the special tool.

TOOL:

Fork seal driver, 45 mm I.D. 07KMD-KZ30100 or
07KMD-KZ3010A
(U.S.A. only)

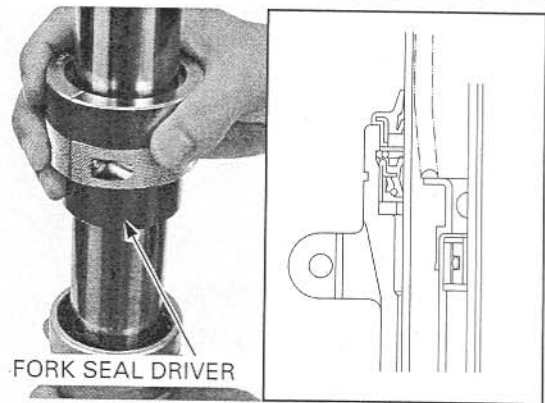

Install the stopper ring into the fork slider groove securely.

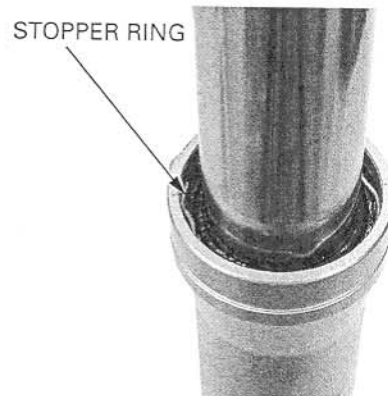

Install the dust seal.



Install the fork damper assembly into the fork tube.

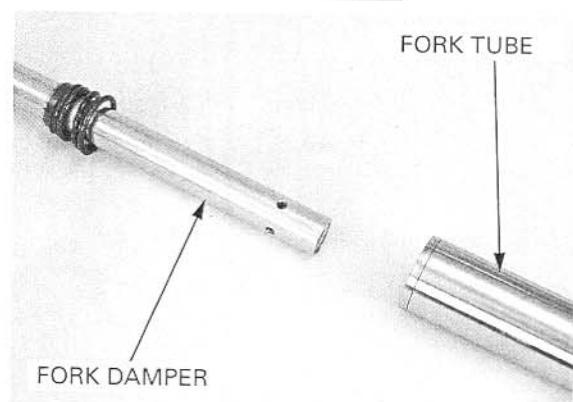

FRONT WHEEL/SUSPENSION/STEERING

Apply a locking agent to the fork socket bolt threads.
Install the socket bolt with a new sealing washer.

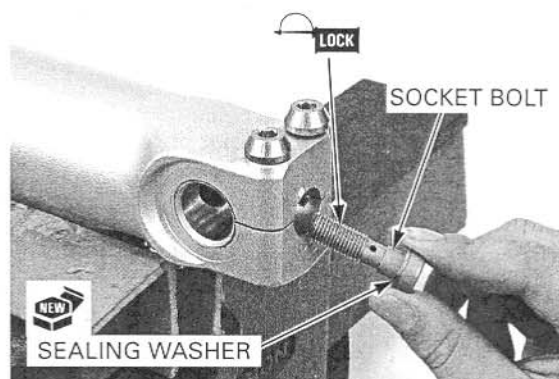

Hold the fork slider in a vise with soft jaws or a shop towel.

Tighten the fork socket bolt to the specified torque.

TORQUE: 34 N·m (3.5 kgf·m, 25 lbf·ft)

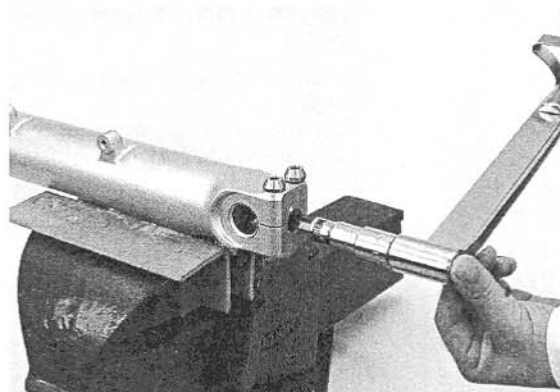

If the fork damper turns together with the socket bolt, temporarily install the fork spring, spring seats, collar, joint plate and fork bolt.

Pour the specified amount of recommended fork fluid into the fork tube.

RECOMMENDED FORK FLUID:

Pro Honda Suspension Fluid SS-8

FORK FLUID CAPACITY:

531 ± 2.5 cm³ (18.0 ± 0.08 US oz, 18.7 ± 0.09 Imp oz)

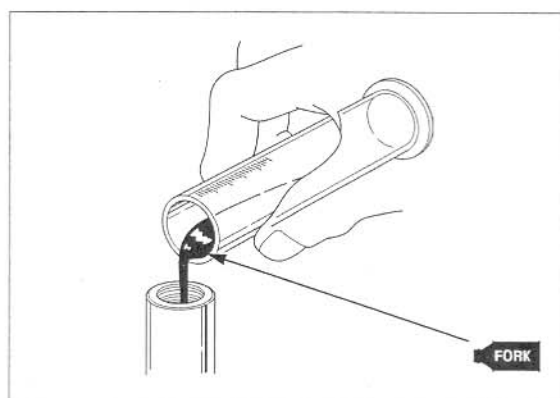

Pump the damper rod several times until the fork fluid flows out of the oil hole in the rebound damping adjuster.

Slowly pump the fork tube several times to remove the trapped air.

Compress the fork tube slowly.

Measure the fluid level from the top of the fork tube.

FORK FLUID LEVEL: 110 mm (4.3 in)

Be sure the fluid level is the same in the both forks.

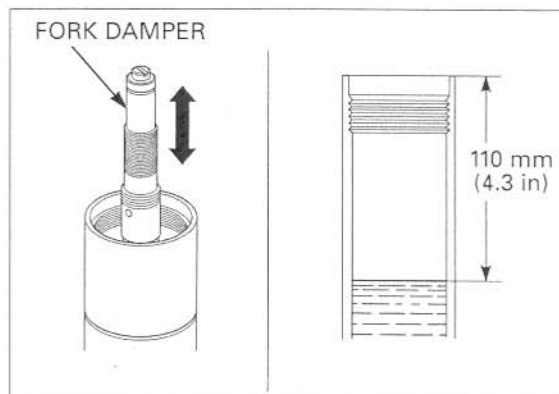

FRONT WHEEL/SUSPENSION/STEERING

Pull the damper rod up and install the fork spring with the tapered end facing up.

Install the following:

- Spring seats
- Spring collar
- Spring joint plate

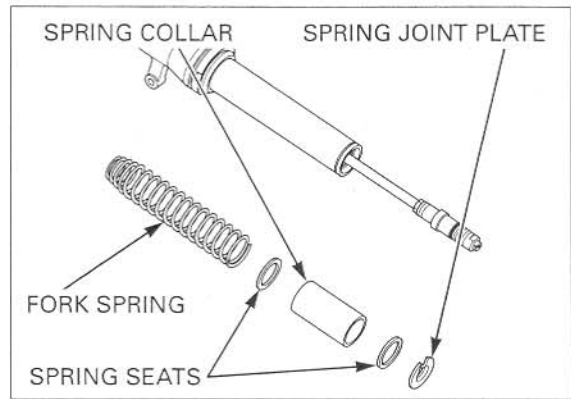

Apply fork fluid to a new O-ring and install it onto the fork bolt.

Screw the fork bolt to the rebound adjuster until it seats.

Hold the rebound adjuster with a 14 mm wrench and tighten the fork bolt.

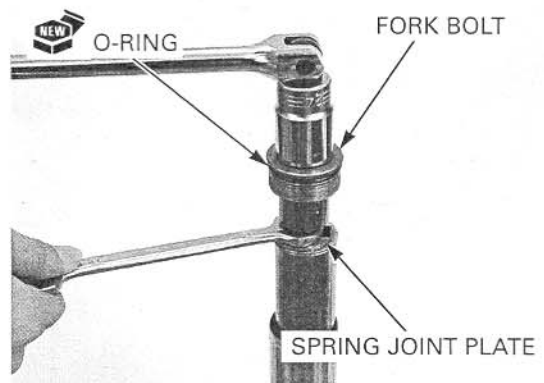

Screw the fork bolt into the fork tube.

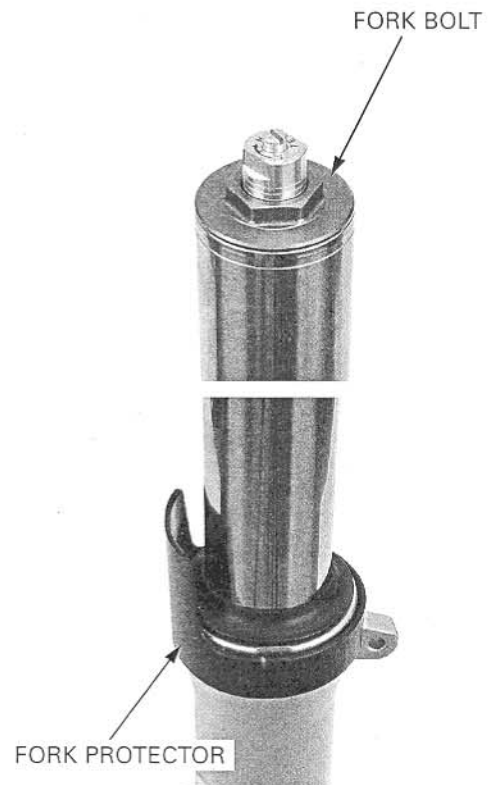

Install the fork protector.

INSTALLATION

Install the fork leg through the bottom bridge, handlebar and top bridge (page 14-37).

Align the top surface of the top bridge with the index line of the outer tube as shown.

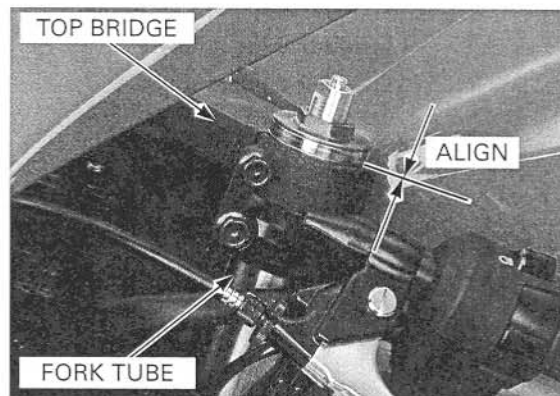

Tighten the bottom pinch bolts to the specified torque.

TORQUE: 27 N·m (2.7 kgf·m, 20 lbf·ft)

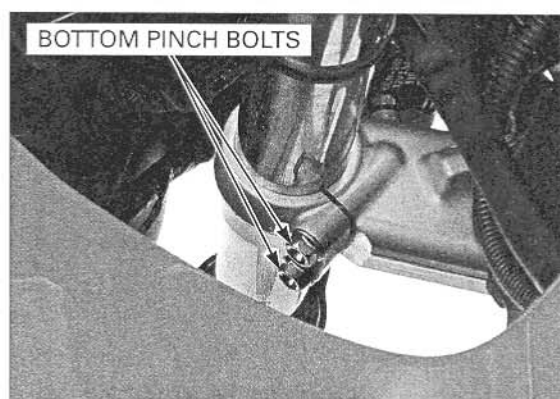

If the fork bolt was loosened, tighten it to the specified torque.

TORQUE: 23 N·m (2.3 kgf·m, 17 lbf·ft)

Tighten the handlebar pinch bolt securely.

Tighten the top bridge pinch bolt to the specified torque.

TORQUE: 23 N·m (2.3 kgf·m, 17 lbf·ft)

Install the front fender (page 3-15) and front wheel (page 14-17).

Adjust the pre-load and damping adjusters (page 4-30).

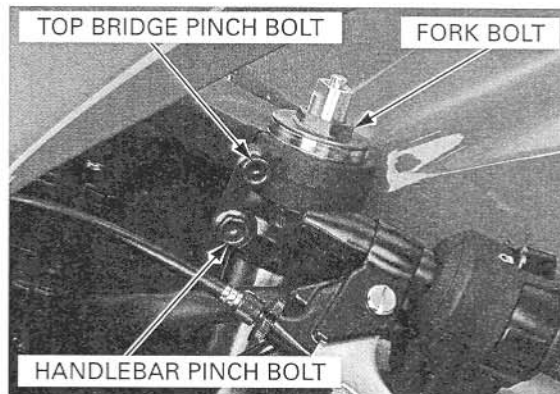

STEERING STEM

REMOVAL

Remove the following:

- Front wheel (page 14-12)
- Front fender (page 3-15)
- Upper cowl (page 3-9)
- Fuel tank cover (page 3-15)

Release the wire band and disconnect the ignition switch 4P (Natural) connector.

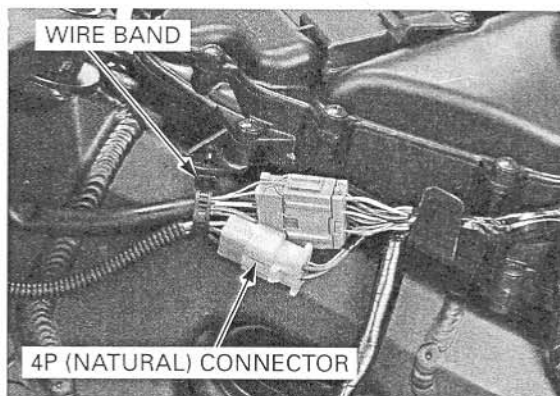

FRONT WHEEL/SUSPENSION/STEERING

Remove the steering stem nut cap and stem nut.
Remove the top bridge pinch bolts and top bridge.

Remove the following:

- Handlebars (page 14-7)
- Fork legs (page 14-18)

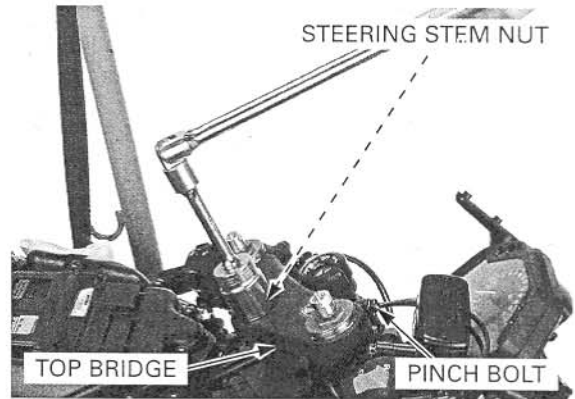

Remove the bolt and front brake hose clamp.

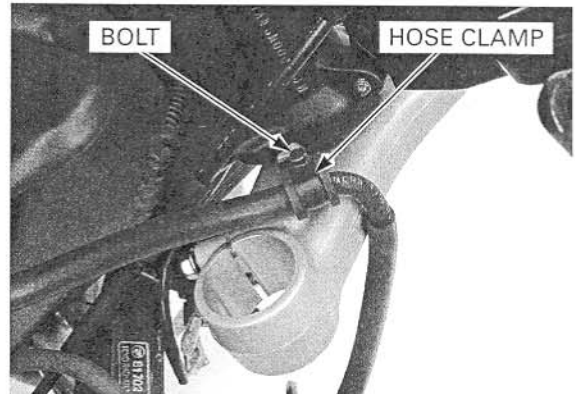

Straighten the tabs of the lock washer.

Remove the adjusting lock nut and lock washer.

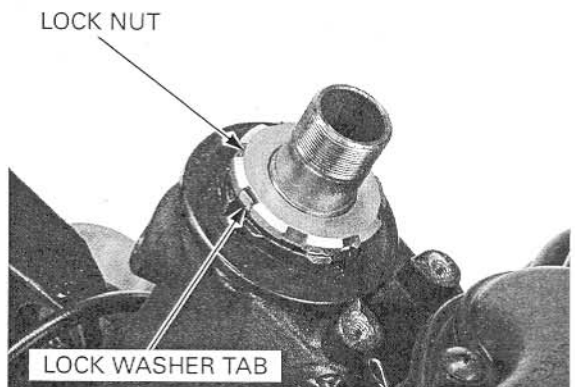

Remove the steering stem adjusting nut using the special tool.

TOOL:

Steering stem socket

07916-3710101 or
07916-3710100
(U.S.A. only)

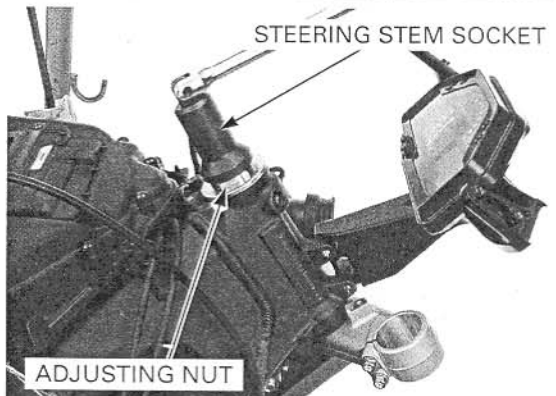

FRONT WHEEL/SUSPENSION/STEERING

Remove the following:

- Dust seal
- Upper bearing inner race
- Upper bearing
- Steering stem
- Lower bearing

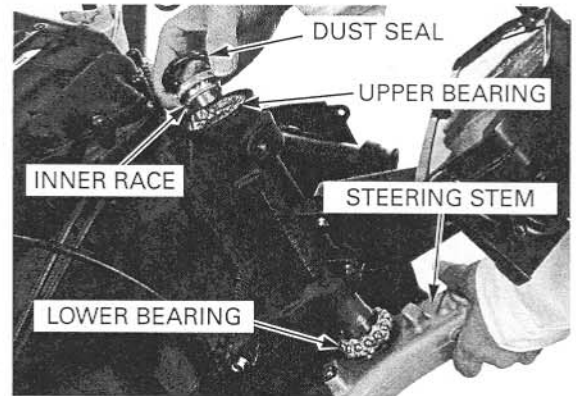

BEARING REPLACEMENT

Always replace the bearings and races as a set.

Replace the races using the special tools as described in the following procedure.

*For U.S.A. only
outer race replacement, refer to (page 14-32).*

TOOLS: (Not available in U.S.A.)

- | | |
|-------------------------------|---------------|
| (1) Driver attachment (upper) | 070MF-MCJ0100 |
| (2) Driver attachment (lower) | 070MF-MCJ0200 |
| (3) Driver shaft assembly | 07946-KM90301 |
| (4) Bearing remover, A | 07946-KM90401 |
| (5) Bearing remover, B | 07NMF-MT70110 |
| (6) Assembly base | 07946-KM90600 |

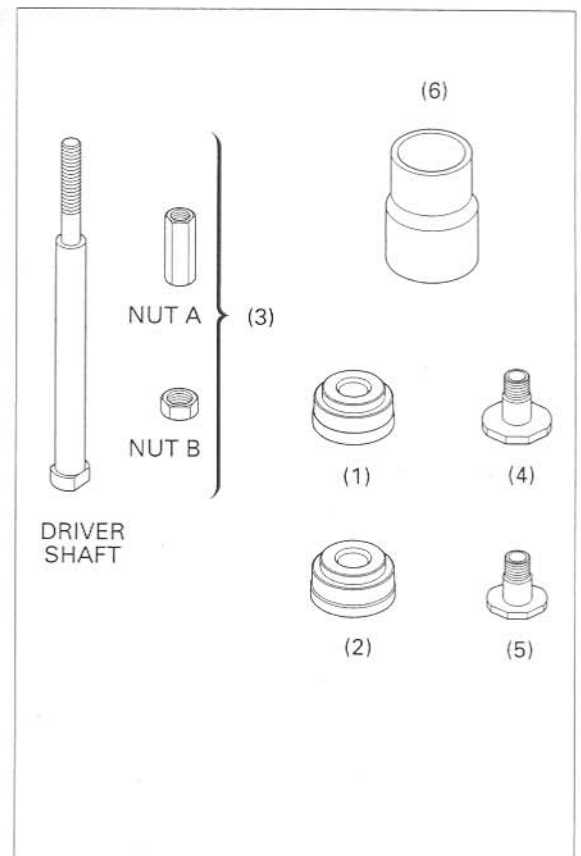

FRONT WHEEL/SUSPENSION/STEERING

Note the installation direction of the assembly base; the small I.D. side facing the upper attachment.

Install the special tools into the steering head as shown.

Align the bearing remover A with the grooves in the steering head.

Lightly tighten the nut B with a wrench.

Holding the driver shaft with a wrench, turn the nut A gradually to remove the upper outer race.

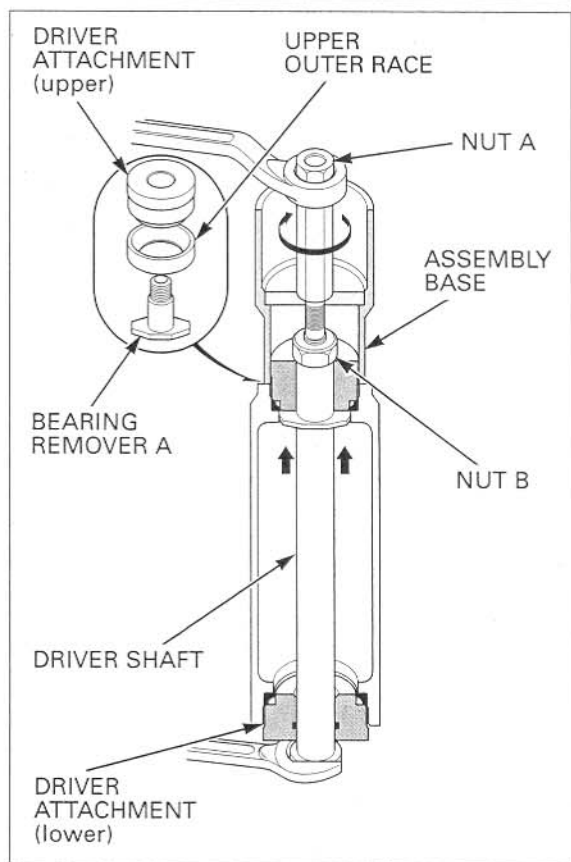

Note the installation direction of the assembly base; the large I.D. side facing the lower attachment.

Install the special tools into the steering head as shown and remove the lower outer race using the same procedure as for the upper outer race.

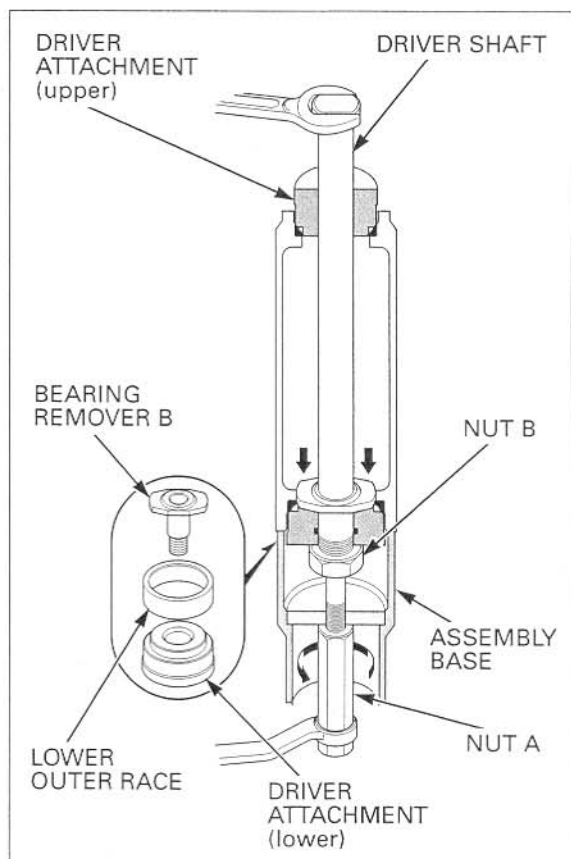

FRONT WHEEL/SUSPENSION/STEERING

Remove any burrs from the outer race installation surface of the steering head.

Note the installation direction of the assembly base; the large I.D. side facing the lower attachment.

Install a new upper outer race with the special tools as shown.

Hold the driver shaft with a wrench and turn the nut A gradually until upper outer race is fully seated.

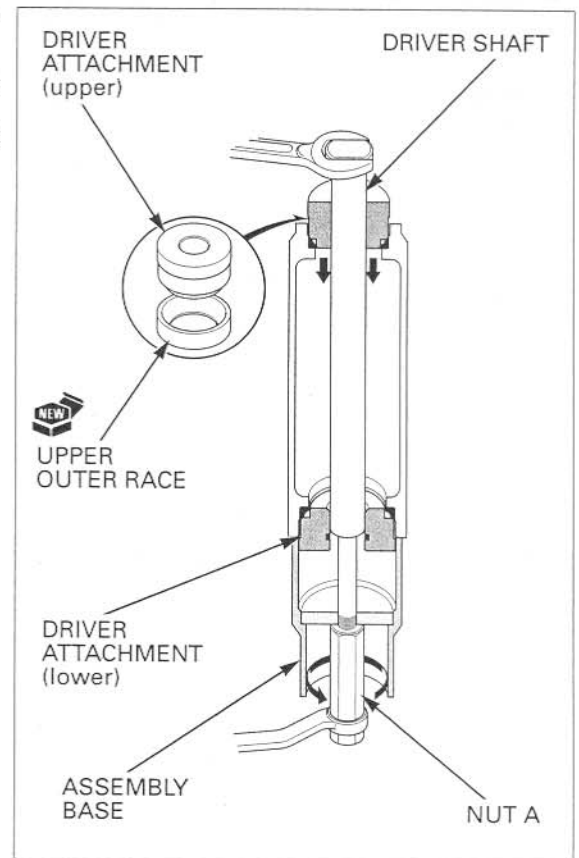

Remove any burrs from the outer race installation surface of the steering head.

Note the installation direction of the assembly base; the small I.D. side facing the upper attachment.

Install a new lower outer race with the special tools as shown.

Hold the driver shaft with a wrench and turn the nut A gradually until lower outer race is fully seated.

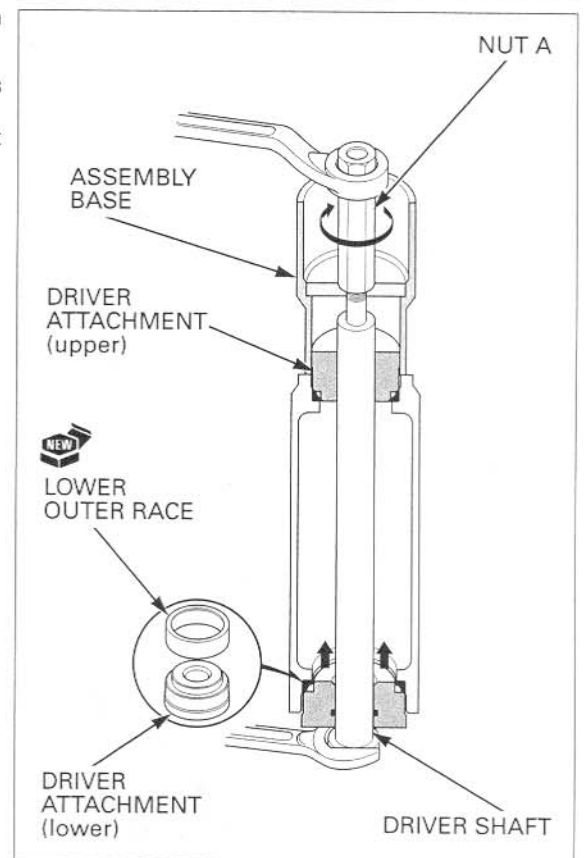

FRONT WHEEL/SUSPENSION/STEERING

U.S.A. only:

Place the steering head bearing outer races using the special tools listed below.

TOOLS:

Main bearing driver attachment	07946-ME90200
Fork seal driver weight	07947-KA50100
Oil seal driver	07965-MA60000
Installer shaft	07VMF-KZ30200
Installer attachment A	07VMF-MAT0100
Installer attachment B	07VMF-MAT0200
Remover attachment C	07AMF-MEEA100
Remover attachment D	07AMF-MEEA200

Install the special tools into the steering head pipe as shown.

Align the remover attachment C with the groove in the steering head.

While holding the installer shaft with the wrench, turn the upper nut gradually to remove the upper bearing outer race.

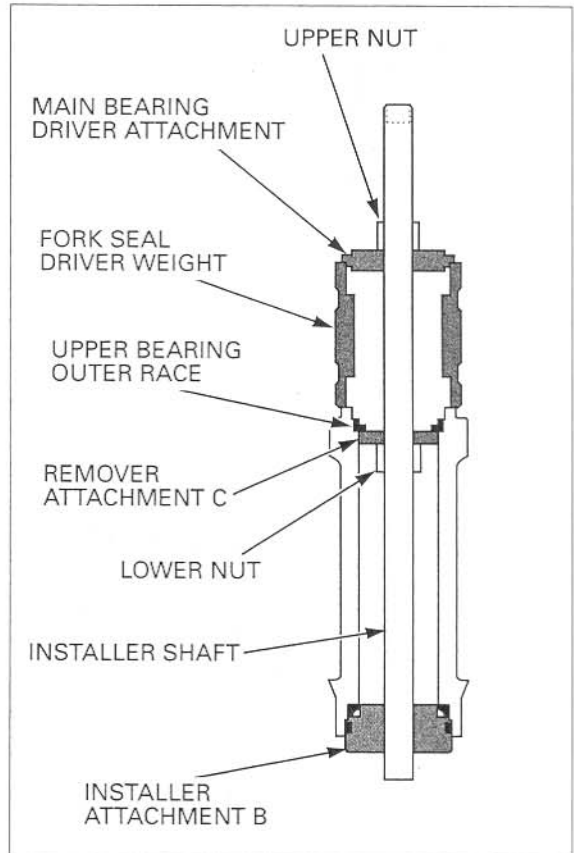

Install the special tools into the steering head pipe as shown.

Align the remover attachment D with the groove in the steering head.

While holding the installer shaft with the wrench, turn the lower nut gradually to remove the lower bearing outer race.

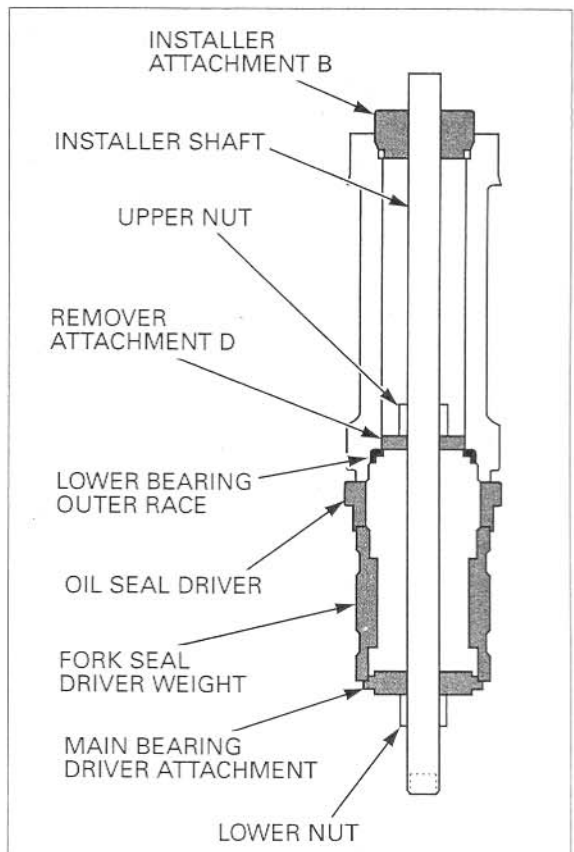

FRONT WHEEL/SUSPENSION/STEERING

Install a new upper bearing outer race and the special tools as shown.

While holding the installer shaft with the wrench, turn the lower nut gradually until the groove in the steering head. This will allow you to install the upper bearing outer race.

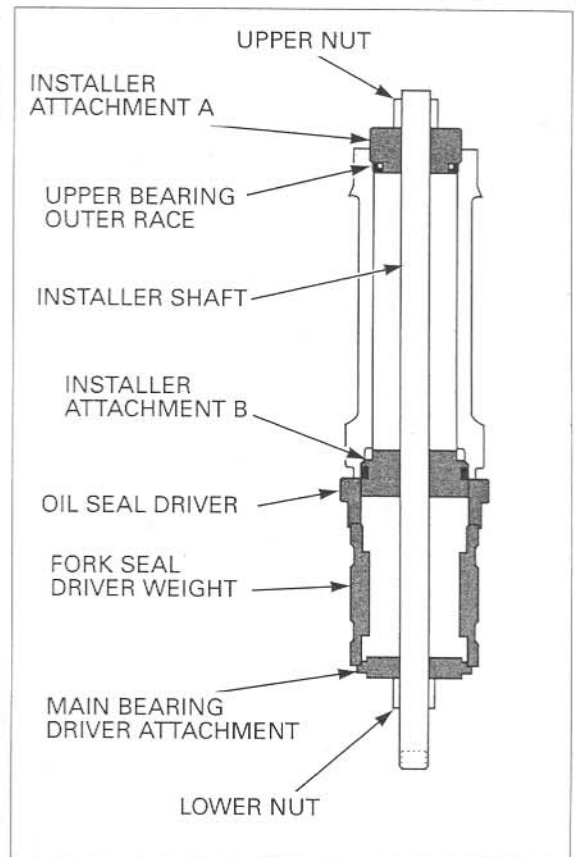

Install a new lower bearing outer race and the special tools as shown.

While holding the installer shaft with the wrench, turn the upper nut gradually until the groove in the installer attachment B aligns with the lower end of the steering head. This will allow the installation of the lower bearing outer race.

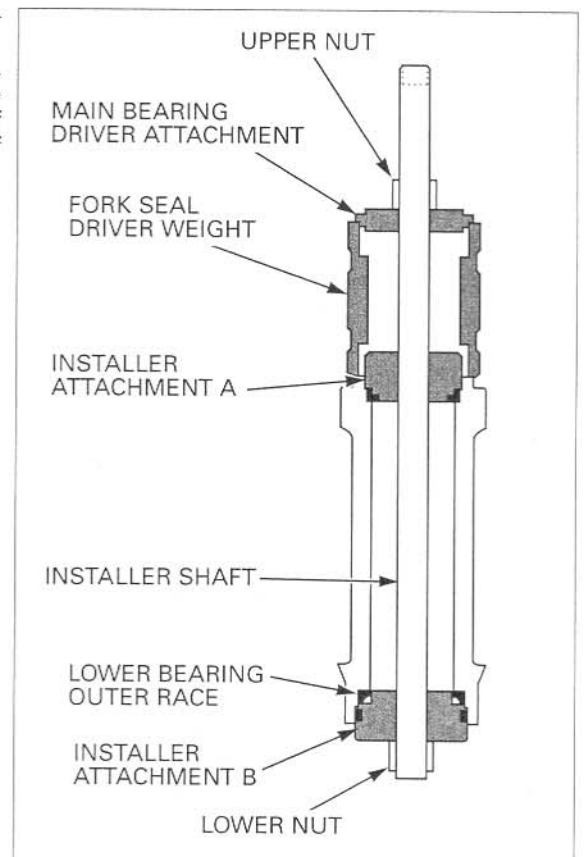

FRONT WHEEL/SUSPENSION/STEERING

LOWER INNER RACE REPLACEMENT

Temporarily install the steering stem nut onto the stem to prevent the threads from being damaged when removing the lower bearing inner race from the stem.

Remove the lower bearing inner race with a chisel or equivalent tool, being careful not to damage the stem.

Remove the dust seal.

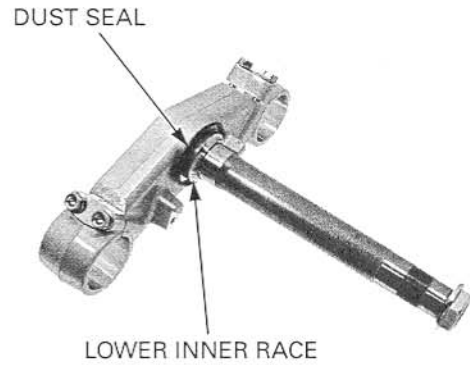

Apply grease to a new dust seal lips and install it over the steering stem.

Install a new lower bearing inner race using a special tool and a hydraulic press.

TOOL:

Steering stem driver

07946-MB00000

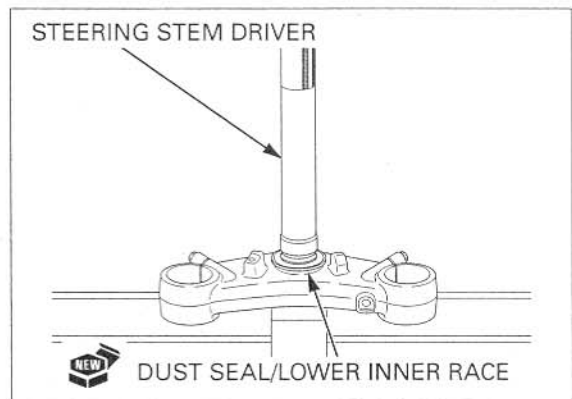

INSTALLATION

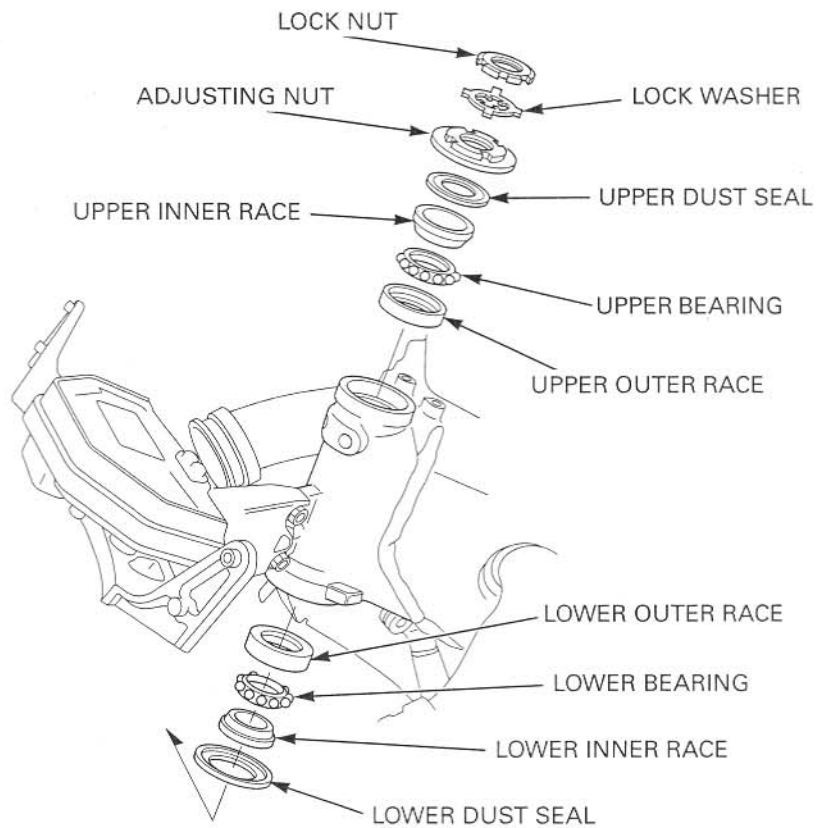
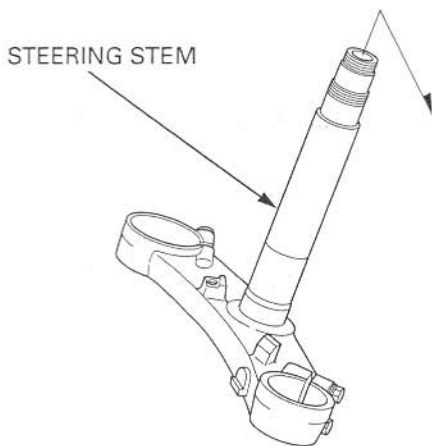

FRONT WHEEL/SUSPENSION/STEERING

Apply grease to the upper and lower bearings and bearing races.

Install the lower bearing onto the steering stem.
Insert the steering stem into the steering head pipe.

Install the upper bearing, inner race and dust seal.

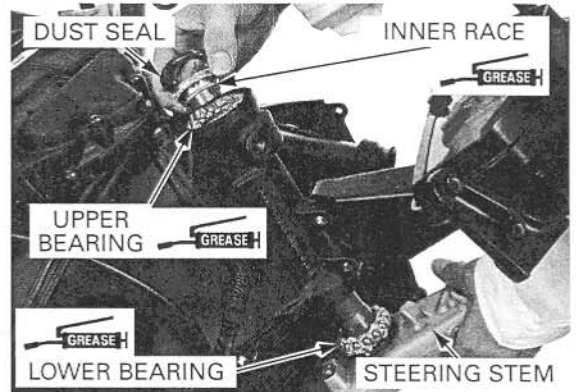

Apply oil to the adjusting nut threads.
Install and tighten the steering stem adjusting nut to the initial torque.

TOOL:

Steering stem socket

07916-3710101 or
07916-3710100 or
07702-0020001
(U.S.A. only)

TORQUE: 30 N·m (3.1 kgf·m, 22 lbf·ft)

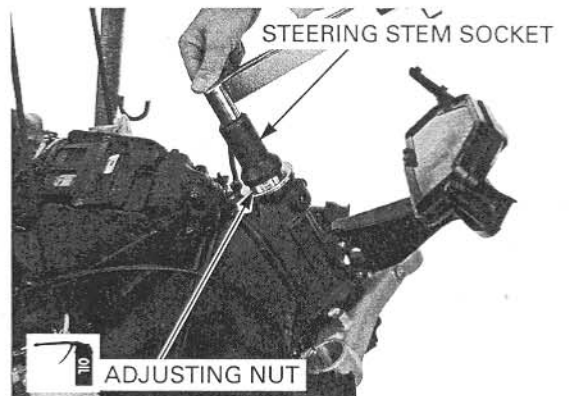

Move the steering stem right and left, lock-to-lock, several times to seat the bearings.

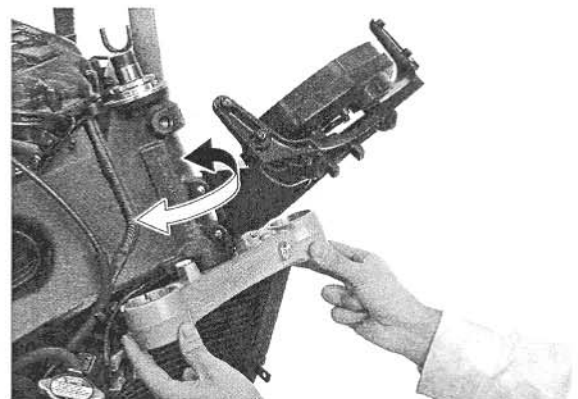

Retighten the bearing adjusting nut to the specified torque.

TORQUE: 47 N·m (4.8 kgf·m, 35 lbf·ft)

Recheck that the steering stem moves smoothly without play or binding.

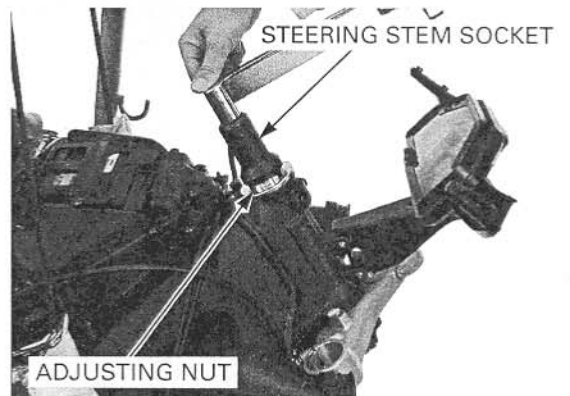

FRONT WHEEL/SUSPENSION/STEERING

Install the new lock washer onto the steering stem.
Align the tabs of the lock washer with the grooves in the adjusting nut and bend two opposite tabs (shorter) down into the adjusting nut groove.

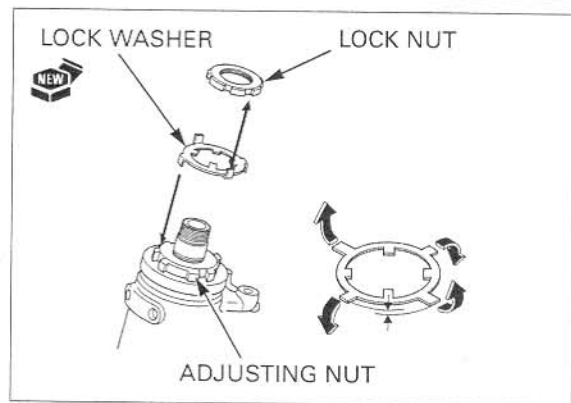

Install and finger tighten the lock nut.
Hold the lock nut and further tighten the lock nut within 1/4 turn (90°) enough to align its grooves with the lock washer tabs.

Bend the lock washer tabs up into the lock nut grooves.

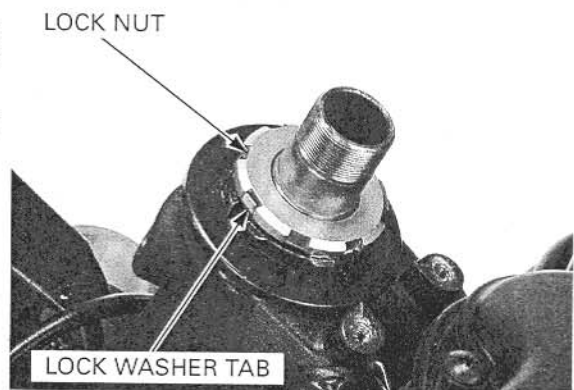

Install the front brake hose clamp and tighten the bolt to the specified torque.

TORQUE: 12 N·m (1.2 kgf·m, 9 lbf·ft)

Install the following:

- Handlebar (page 14-9)
- Fork legs (page 14-27)

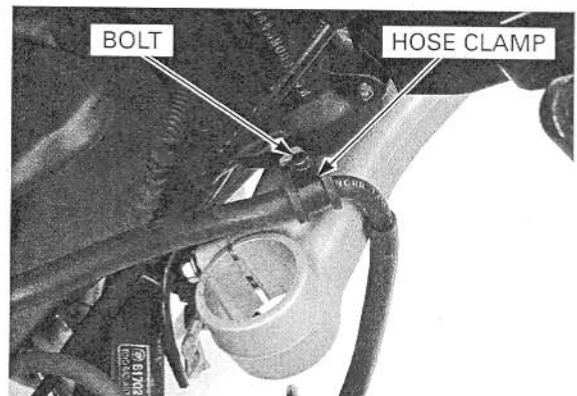

Connect the ignition switch 4P (Natural) connector and clamp the wire band.

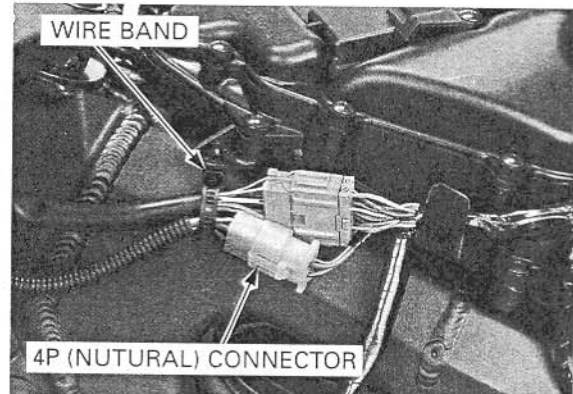

FRONT WHEEL/SUSPENSION/STEERING

Install the top bridge and steering stem nut.
Tighten the steering stem nut to the specified torque.

TORQUE: 103 N·m (10.5 kgf·m, 76 lbf·ft)

Move the steering stem right and left, lock-to-lock, several times.

Make sure the steering stem moves smoothly, without play or binding; then loosen the steering stem adjusting nut.

Install the steering stem nut cap.

Install the following:

- Upper cowl (page 3-9)
- Front fender (page 3-15)
- Front wheel (page 14-17)
- Fuel tank cover (page 3-15)

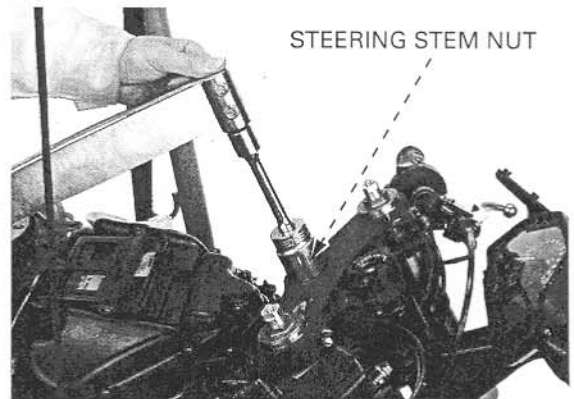

STEERING HEAD BEARING PRE-LOAD

Jack-up the motorcycle to raise the front wheel off the ground.

Position the steering stem to the straight ahead position.

Make sure that there is no cable or wire harness interference.

Hook a spring scale to the fork tube and measure the steering head bearing pre-load.

The pre-load should be within 9.8 – 15 N·m (1.0 – 1.5 kgf·m).

If the readings do not fall within the limits, lower the front wheel to the ground and adjust the steering bearing adjusting nut.

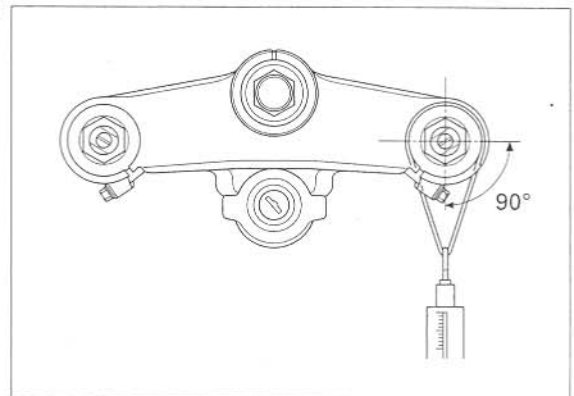

15. REAR WHEEL/SUSPENSION

COMPONENT LOCATION	15-2	SHOCK ABSORBER	15-15
SERVICE INFORMATION	15-3	SUSPENSION LINKAGE	15-18
TROUBLESHOOTING	15-7	SWINGARM	15-21
REAR WHEEL	15-8		

REAR WHEEL/SUSPENSION COMPONENT LOCATION

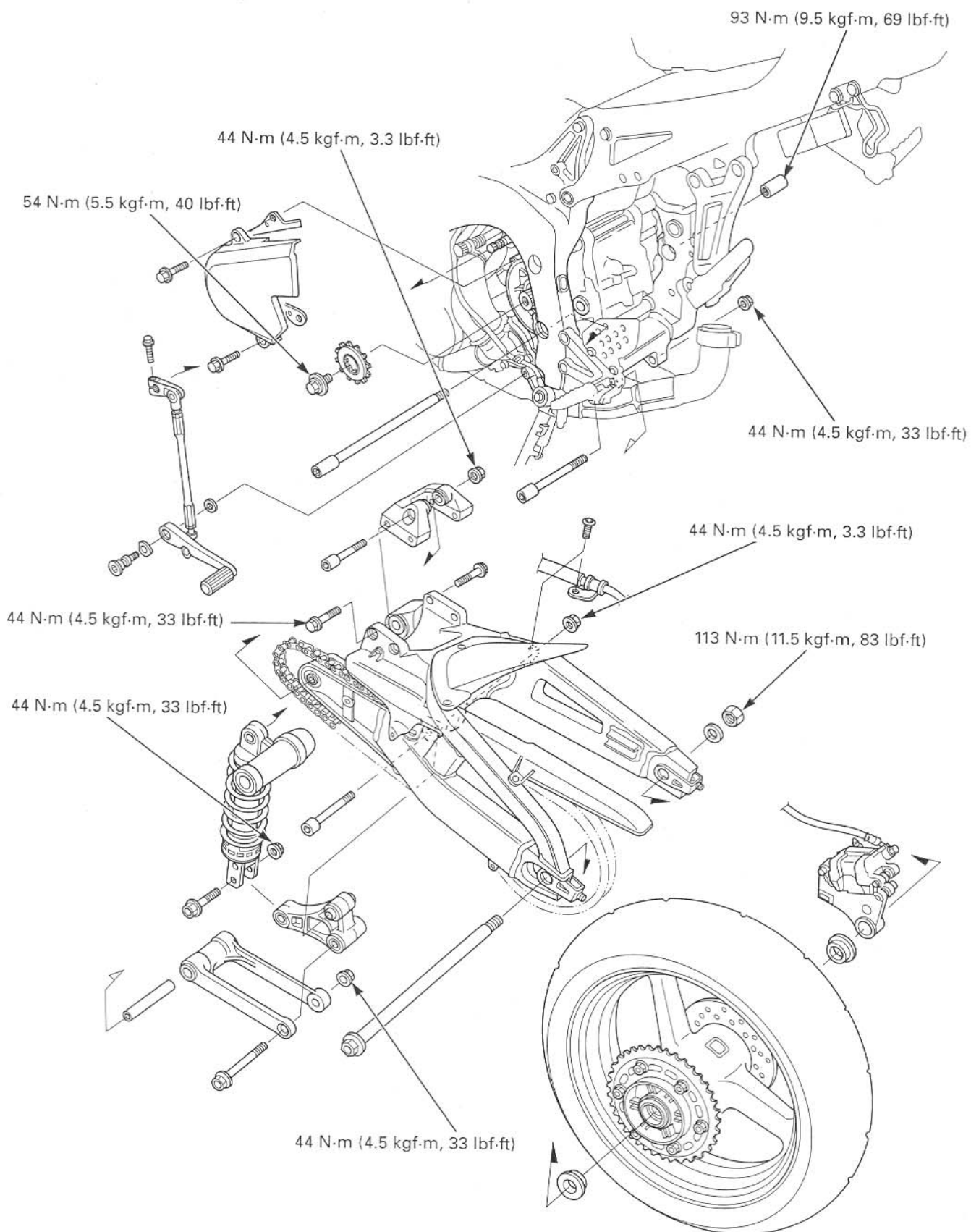

SERVICE INFORMATION

GENERAL

- A contaminated brake disc or pad reduces stopping power. Discard contaminated pads and clean a contaminated disc with a high quality brake degreasing agent.
- After the rear wheel installation, check the brake operation by applying the brake pedal.
- The shock absorber contains nitrogen under high pressure. Do not allow fire or heat near the shock absorber.
- Before disposal of the shock absorber, release the nitrogen (page 15-17).
- When servicing the rear wheel and suspension, support the motorcycle using a safety stand or hoist.
- Use only tires marked "TUBELESS" and tubeless valves on rim marked "TUBELESS TIRE APPLICABLE".
- Use genuine Honda replacement bolts and nuts for all suspension pivot and mounting point.
- When installing the swingarm, be sure to tighten the swingarm pivot fasteners to the specified torque in the specified sequence. If you mistake the tightening torque or sequence, loosen all pivot fasteners, then tighten them again to the specified torque in the correct sequence.
- Refer to the brake system information (page 16-4).

SPECIFICATIONS

Unit: mm (in)



ITEM		STANDARD	SERVICE LIMIT
Minimum tire tread depth		-	2.0 (0.08)
Cold tire pressure	Driver only	290 kPa (2.90 kgf/cm ² , 42 psi)	-
	Driver and passenger	290 kPa (2.90 kgf/cm ² , 42 psi)	-
Axle runout		-	0.2 (0.01)
Wheel rim runout	Radial	-	2.0 (0.08)
	Axial	-	2.0 (0.08)
Wheel balance weight		-	60 g (2.1 oz) max.
Drive chain	Size/link	DID	DIDH525HV-120ZB
		RK	RK525ROZ1-120LJ-FZ
	Slack	25 - 35 (1 - 1-3/8)	-
Shock absorber	Spring pre-load adjuster standard position		Position 3
	Rebound damping adjuster initial setting		1-3/4 turns out from full hard
	Compression damping adjuster initial setting		2 turns out from full hard

TORQUE VALUES





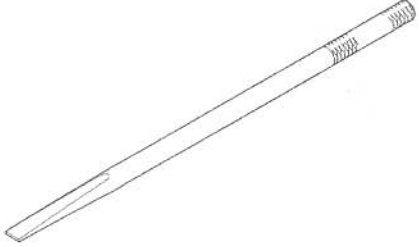
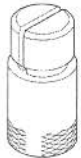
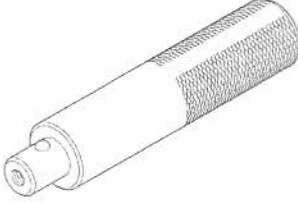
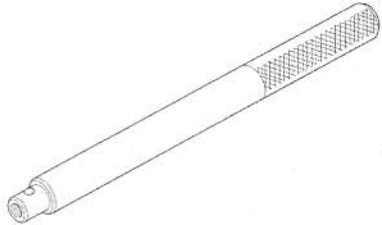
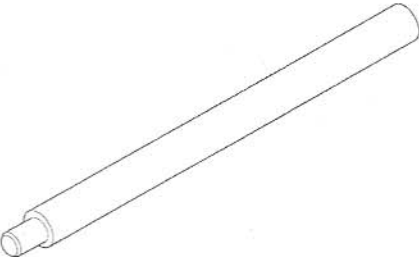
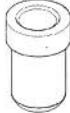
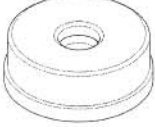





Rear brake disc bolt	42 N·m (4.3 kgf·m, 31 lbf·ft)	ALOC bolt: replace with a new one
Final driven sprocket nut	64 N·m (6.5 kgf·m, 47 lbf·ft)	U-nut
Rear axle nut	113 N·m (11.5 kgf·m, 83 lbf·ft)	U-nut
Rear shock absorber upper mounting nut	44 N·m (4.5 kgf·m, 33 lbf·ft)	U-nut
Rear shock absorber lower mounting nut	44 N·m (4.5 kgf·m, 33 lbf·ft)	U-nut
Shock link-to-frame pivot nut	44 N·m (4.5 kgf·m, 33 lbf·ft)	U-nut
Shock arm-to-shock link nut	44 N·m (4.5 kgf·m, 33 lbf·ft)	U-nut
Shock arm-to-swingarm nut	44 N·m (4.5 kgf·m, 33 lbf·ft)	U-nut
Rear shock absorber bracket mounting bolt	44 N·m (4.5 kgf·m, 33 lbf·ft)	
Drive chain slider bolt	8.8 N·m (0.9 kgf·m, 6.5 lbf·ft)	ALOC bolt: replace with a new one
Swingarm pivot pinch bolt	27 N·m (2.7 kgf·m, 20 lbf·ft)	
Swingarm pivot nut	93 N·m (9.5 kgf·m, 69 lbf·ft)	
Drive sprocket special bolt	54 N·m (5.5 kgf·m, 40 lbf·ft)	

REAR WHEEL/SUSPENSION

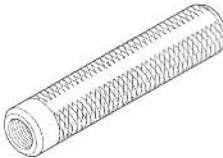
TOOLS

<p>Bearing remover shaft 07GGD-0010100</p> 	<p>Bearing remover head, 25 mm 07746-0050800</p> 	<p>Driver 07749-0010000</p> 
<p>Driver 07949-3710001</p> 	<p>Driver shaft 07946-MJ00100</p> 	<p>Driver head 07946-MJ00201</p> 
<p>Attachment, 37 x 40 mm 07746-0010200</p> 	<p>Attachment, 42 x 47 mm 07746-0010300</p> 	<p>Attachment, 52 x 55 mm 07746-0010400</p> 
<p>Attachment, 24 x 26 mm 07746-0010700</p> 	<p>Attachment, 22 x 24 mm 07746-0010800</p> 	<p>Attachment 40 x 42 mm 07746-0010900</p> 

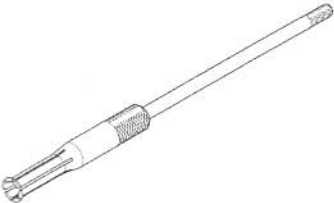
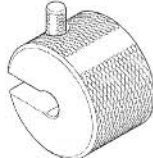
REAR WHEEL/SUSPENSION

<p>Pilot, 17 mm 07746-0040400</p> 	<p>Pilot, 20 mm 07746-0040500</p> 	<p>Pilot, 25 mm 07746-0040600</p> 
<p>Attachment, 28 X 30 mm 07946-1870100</p> 	<p>Remover handle 07936-3710100</p> 	<p>Bearing remover, 17 mm 07936-3710300</p> 
<p>Pilot, 22 mm 07746-0041000</p> 	<p>Pilot, 28 mm 07746-0041100</p> 	<p>Pilot, 28 mm 07JAD-PH80400</p> 
<p>Bearing remover, 20 mm 07936-3710600</p> 	<p>Remover weight 07741-0010201 or 07936-371020A (U.S.A. only)</p> 	<p>Attachment, 34 mm 07ZMD-MBW0100</p> 

REAR WHEEL/SUSPENSION

Attachment, 37 mm
07ZMD-MBW0200



Needle bearing remover
07HMC-MR70100

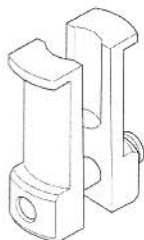

Spherical bearing driver
07HMF-KS60100



TROUBLESHOOTING

Soft suspension

- Weak shock absorber spring
- Incorrect suspension adjustment
- Oil leakage from damper unit
- Insufficient tire pressure

Hard suspension

- Incorrect suspension adjustment
- Damaged rear suspension pivot bearings
- Bent damper rod
- Bent swingarm pivot
- Tire pressure too high

Rear wheel wobbling

- Bent rim
- Worn or damaged rear wheel bearings
- Faulty rear tire
- Unbalanced rear tire and wheel
- Insufficient rear tire pressure
- Faulty swingarm pivot bearings

Rear wheel turns hard

- Faulty rear wheel bearings
- Bent rear axle
- Rear brake drag
- Drive chain too tight

Rear suspension noise

- Faulty rear shock absorber
- Loose rear suspension fasteners
- Worn rear suspension pivot bearings

Steers to one side or does not track straight

- Bent rear axle
- Axle alignment/chain adjustment not equal on both sides

REAR WHEEL/SUSPENSION

REAR WHEEL

REMOVAL

Support the motorcycle using a safety stand or a hoist, raise the rear wheel off the ground.

Adjust the drive chain slack fully (page 4-21).

Remove the axle nut and washer.

Push the rear wheel forward.
Remove the rear axle.

Derail the drive chain from the driven sprocket.

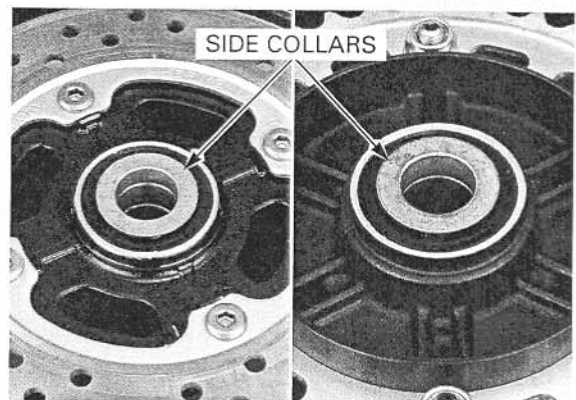
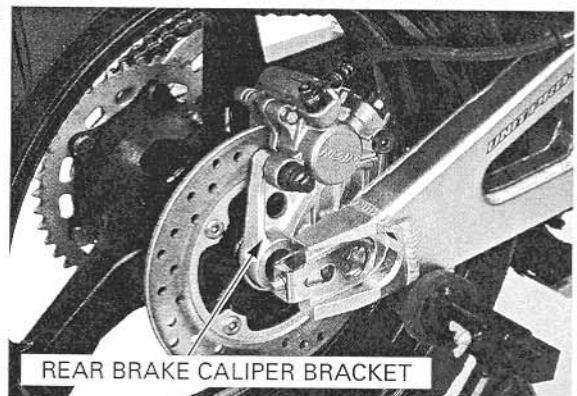
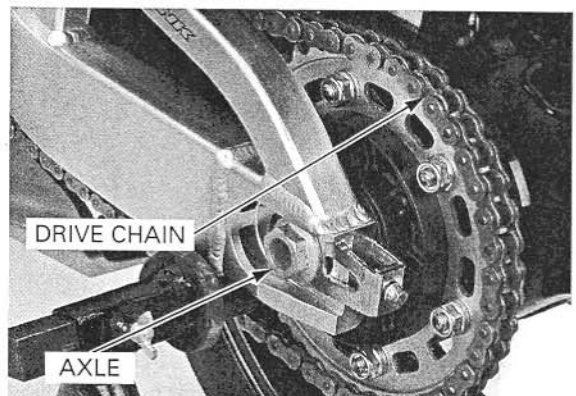
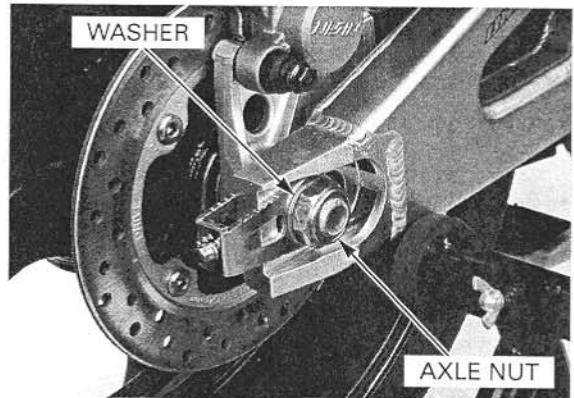

Do not hang the caliper by the brake hose. Do not twist the brake hose.

Do not operate the brake pedal after removing the rear wheel.

Remove the rear brake caliper bracket by moving it backward.

Remove the rear wheel.

Remove the side collars.

INSPECTION

Axle

Place the axle on V-blocks and measure the runout. Actual runout is 1/2 the total indicator reading.

SERVICE LIMIT: 0.2 mm (0.01 in)

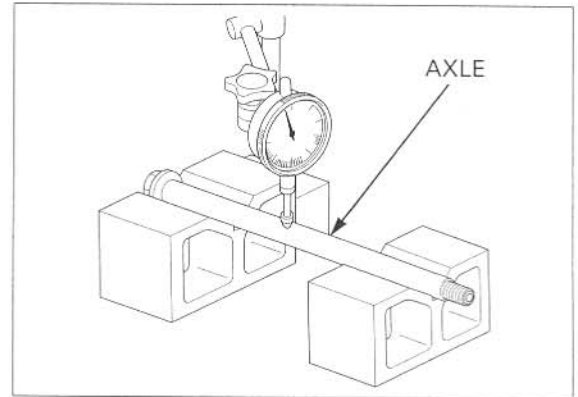

Wheel bearing

Turn the inner race of each bearing with your finger. Bearings should turn smoothly and quietly. Also check that the bearing outer race fits tightly in the hub or driven flange.

Replace the wheel bearings in pairs.

Remove and discard the bearings if the races do not turn smoothly and quietly, or if they fit loosely in the hub or driven flange.

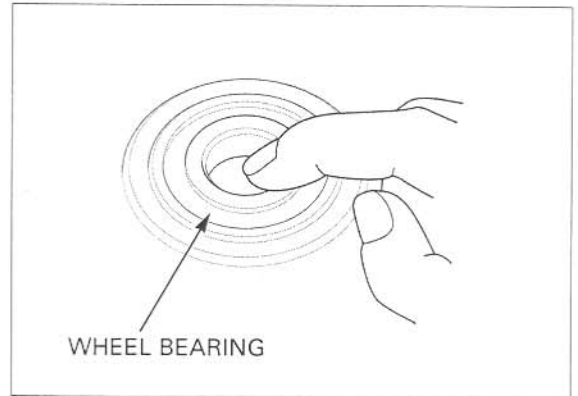

Wheel rim runout

Check the rim runout by placing the wheel in a turning stand.

Spin the wheel slowly and read the runout using a dial indicator.

Actual runout is 1/2 the total indicator reading.

SERVICE LIMITS:

Radial: 2.0 mm (0.08 in)

Axial: 2.0 mm (0.08 in)

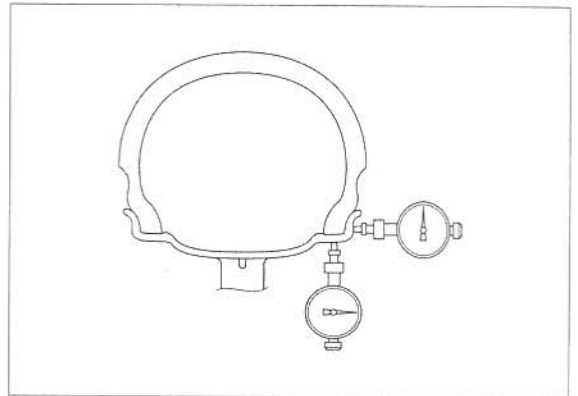

Driven sprocket

Check the condition of the final driven sprocket teeth.

Replace the sprocket if worn or damaged.

- If the final driven sprocket requires replacement, inspect the drive chain and drive sprocket.
- Never install a new drive chain on a worn sprocket or a worn chain on new sprockets. Both chain and sprocket must be in good condition or the replacement chain or sprocket will wear rapidly.

Wheel balance

Refer to the wheel balance servicing (page 14-14).

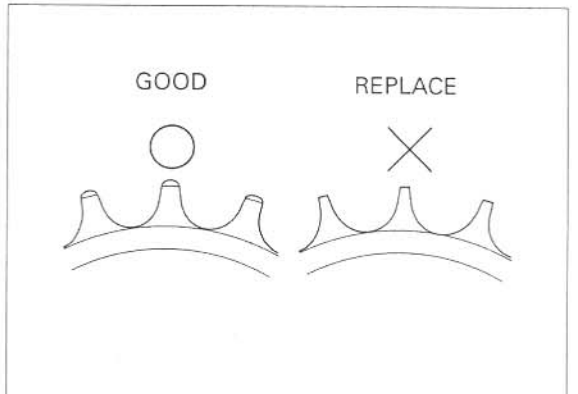

REAR WHEEL/SUSPENSION

DISASSEMBLY

Remove the bolts and brake disc.
Remove the right dust seal.

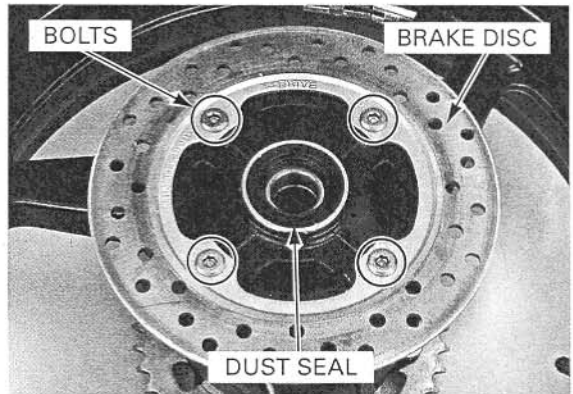

If you will be disassemble the driven flange, loosen the driven sprocket nuts and bolts before removing the driven flange from the wheel hub.

Remove the driven flange assembly from the left wheel hub.

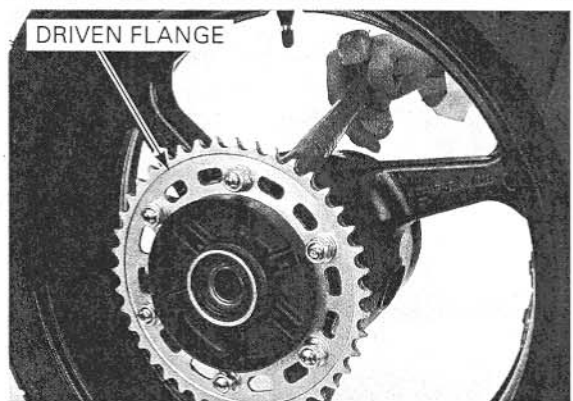

Remove the wheel rubber dampers.
Remove the O-ring.

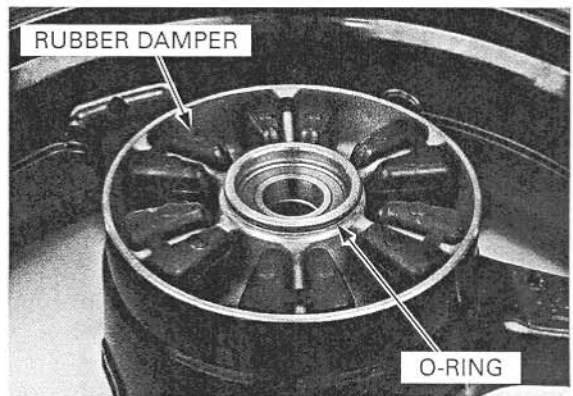

Driven flange bearing removal

Loosen the driven sprocket nuts.

Remove the driven flange from the wheel hub, then remove the driven sprocket nuts, sprocket and bolts.

Remove the dust seal.

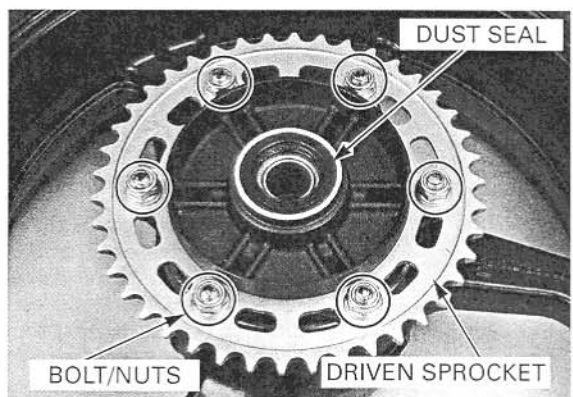

REAR WHEEL/SUSPENSION

Press the driven flange collar out of the driven flange bearings.

TOOLS:

Driver shaft

07946-MJ00100

Driver head

07946-MJ00201

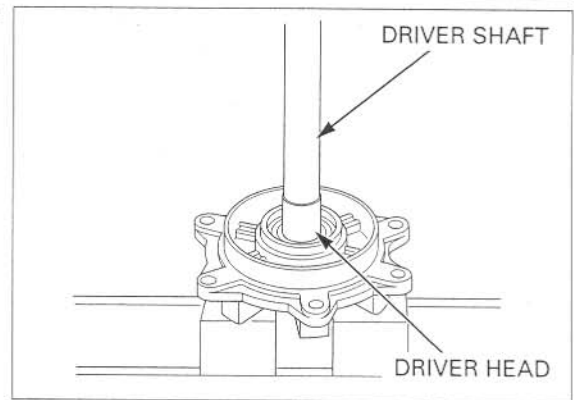

Drive out the driven flange bearings using the special tools.

TOOLS:

Driver

07749-0010000

Attachment, 40 X 42 mm

07746-0010900

Pilot, 28 mm

07JAD-PH80400

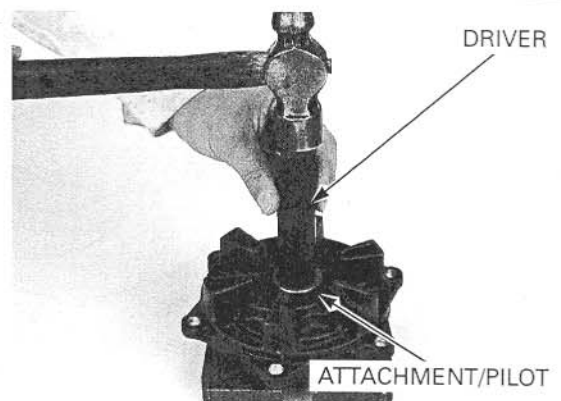

Wheel bearing removal

Install the bearing remover head into the bearing. From the opposite side, install the bearing remover shaft and drive the bearing out of the wheel hub. Remove the distance collar and drive out the other bearing.

TOOLS:

Bearing remover head, 25 mm 07746-0050800

Bearing remover shaft 07GGD-0010100

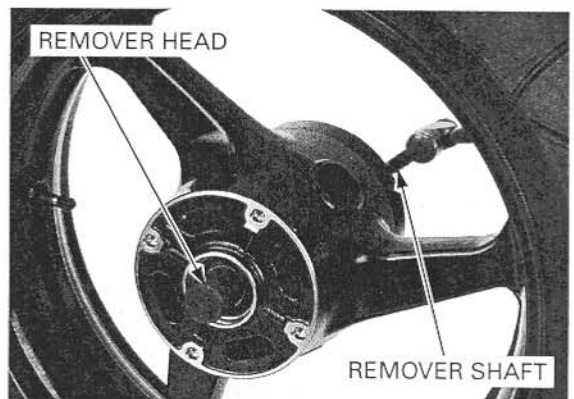

REAR WHEEL/SUSPENSION

ASSEMBLY

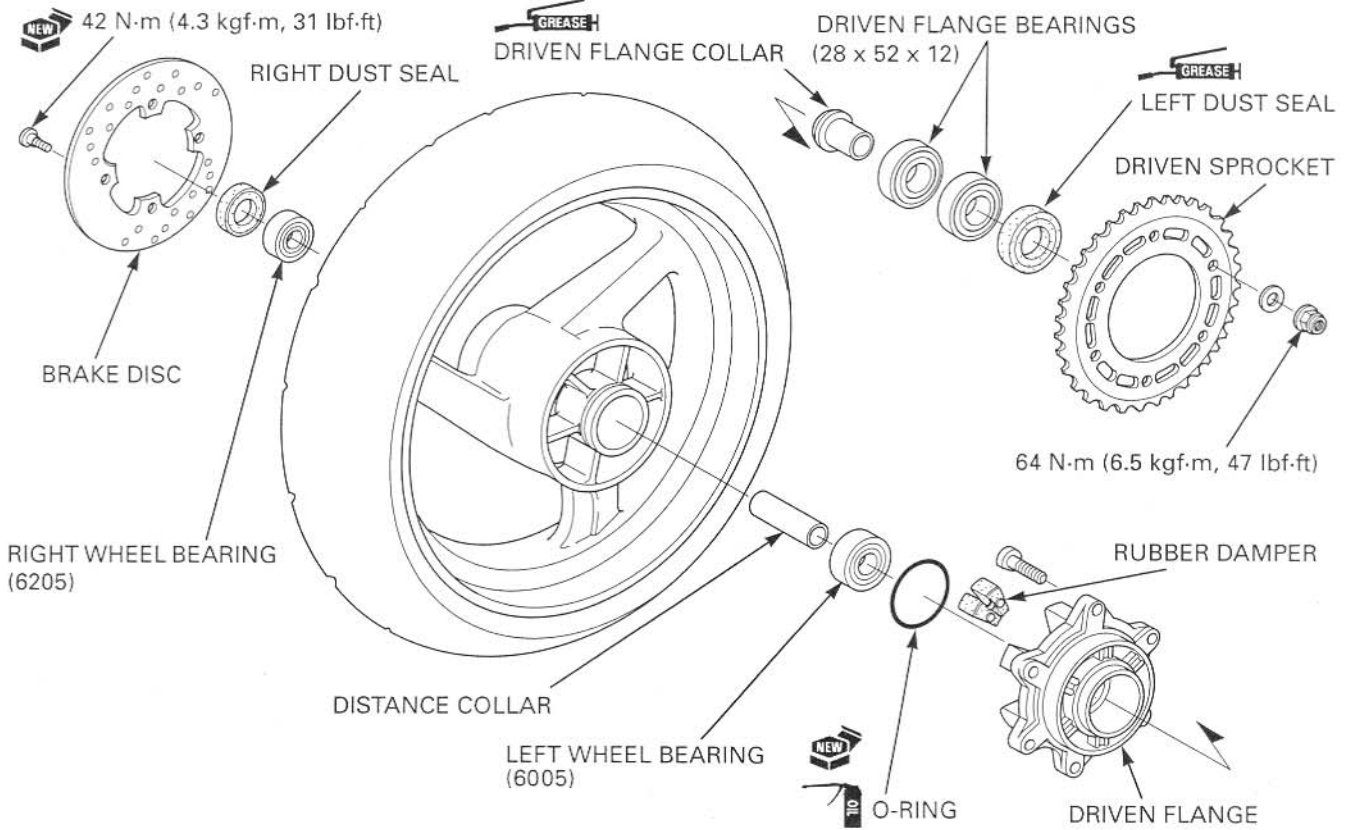

Never install the old bearings, once the bearings has been removed, the bearings must be replaced with new ones.

Wheel bearing installation

Drive in a new left bearing squarely.

TOOLS:

Driver	07749-0010000
Attachment, 42 X 47 mm	07746-0010300
Pilot, 25 mm	07746-0040600

Install the distance collar

Drive in a new right bearing squarely.

TOOLS:

Driver	07749-0010000
Attachment, 52 X 55 mm	07746-0010400
Pilot, 25 mm	07746-0040600

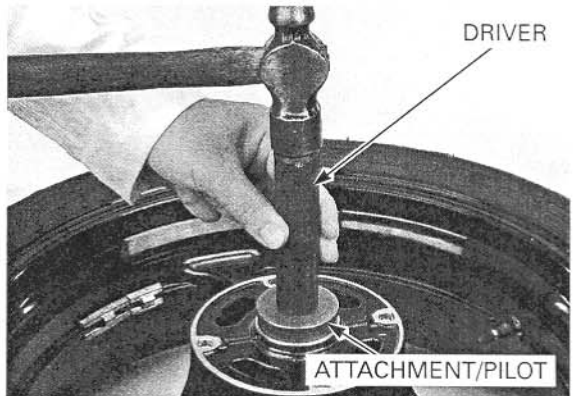
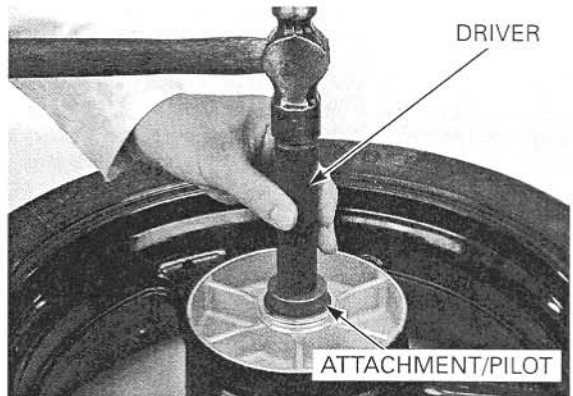

REAR WHEEL/SUSPENSION

Press the driven flange collar in the new driven flange bearings until it is fully seated.

TOOLS:

Driver	07749-0010000
Attachment, 28 X 30 mm	07946-1870100
Pilot, 25 mm	07746-0040600

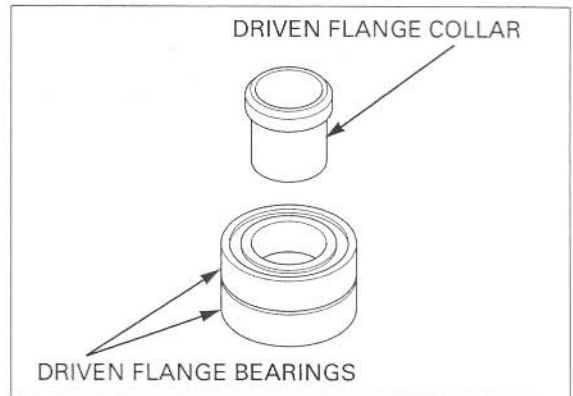

Driven flange bearing installation

Drive the new driven flange bearings/collar into the driven flange using the special tools.

TOOLS:

Driver	07749-0010000
Attachment, 52 X 55 mm	07746-0010400
Pilot, 25 mm	07746-0040600

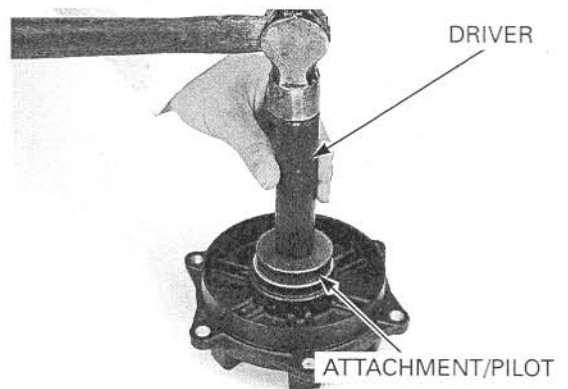

Install the wheel rubber dampers into the wheel hub.

Apply oil to a new O-ring and install it into the groove of the wheel hub.

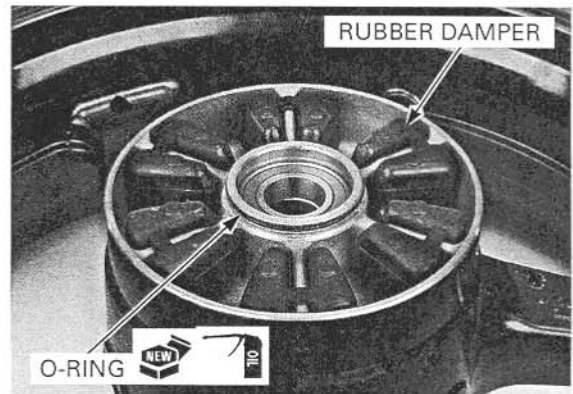

Install the driven flange assembly into the left wheel hub.

If the driven sprocket was removed, install the driven sprocket bolt, sprocket and tighten the nuts to the specified torque.

TORQUE: 64 N·m (6.5 kgf·m, 47 lbf·ft)

Apply grease to a new dust seal lip, then install it into the driven flange.

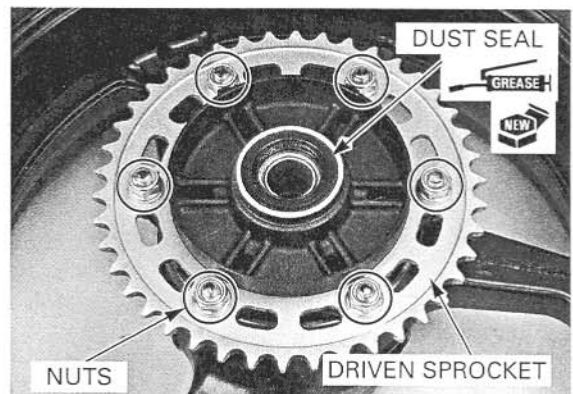

REAR WHEEL/SUSPENSION

Install the brake disc with its rotating direction mark facing out.

Tighten the new brake disc bolts to the specified torque.

TORQUE: 42 N·m (4.3 kgf·m, 31 lbf·ft)

Apply grease to a new dust seal lip, then install it into the wheel hub.

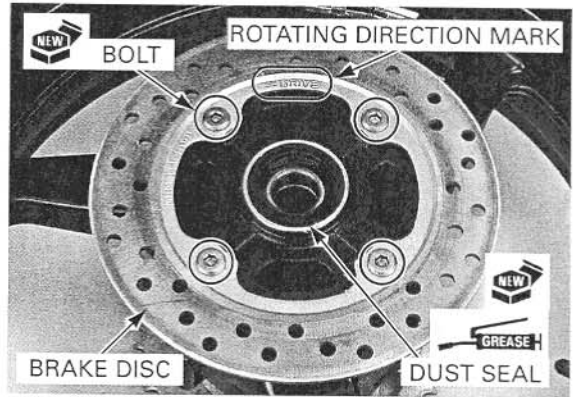

INSTALLATION

Apply grease to the side collars inside and grooves.

Install the side collars.

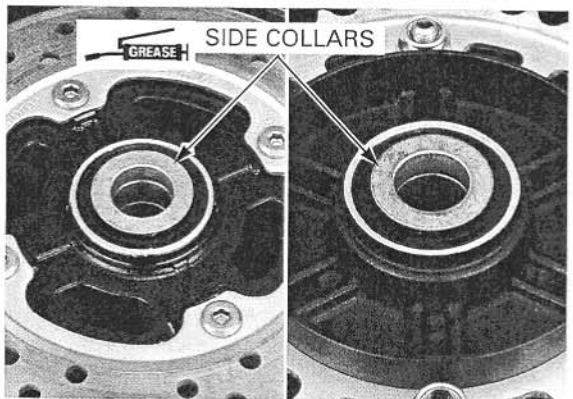

Be careful not to damage the brake pads.

Install the rear brake caliper bracket onto the guide rail of the swingarm while place the rear wheel into the swingarm.

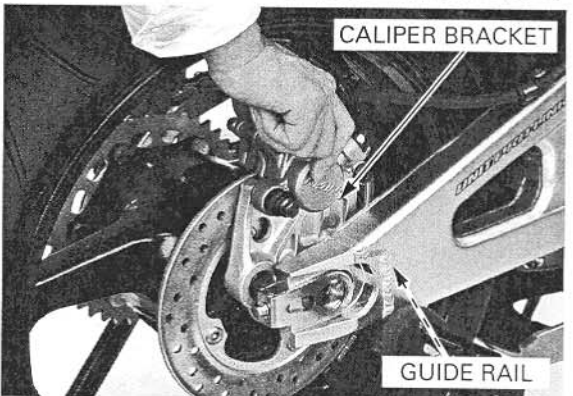

Install the drive chain over the driven sprocket.

Apply a thin coat of grease to the axle.

Install the rear axle from the left side.

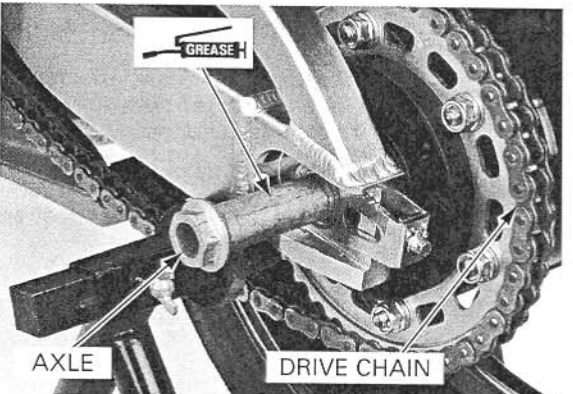

REAR WHEEL/SUSPENSION

Install the washer and axle nut.
Adjust the drive chain slack (page 4-21).
Tighten the axle nut to the specified torque.
TORQUE: 113 N·m (11.5 kgf·m, 83 lbf·ft)

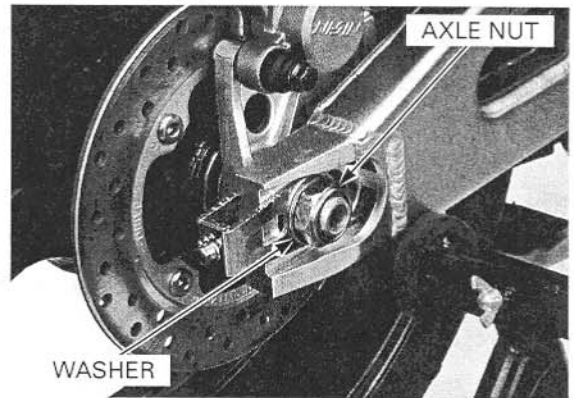

SHOCK ABSORBER

REMOVAL

Support the motorcycle using a hoist or equivalent, and raise the rear wheel off the ground.

Remove the following:

- Rear fender (page 3-16)
- Muffler (page 3-20)
- Rear wheel (page 15-8)

California type only Remove the EVAP Canister (page 4-20).

Remove the shock absorber upper mounting bolt/nut.

Remove the four bolts and rear shock absorber upper mounting bracket from the swingarm.

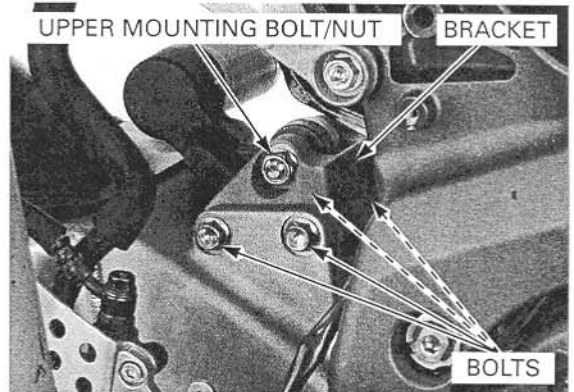

Remove the shock absorber lower mounting bolt/nut.

Remove the shock absorber through the top of the swingarm.

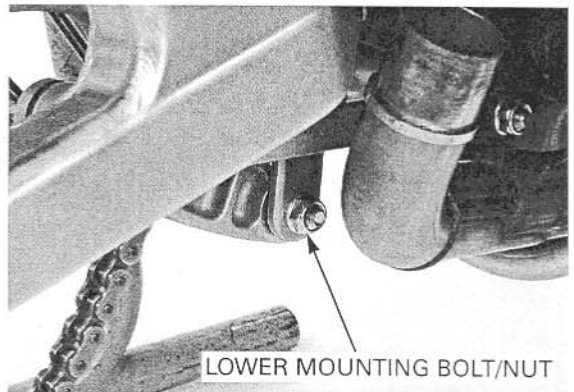

INSPECTION

Visually inspect the shock absorber for damage.

Check the following:

- Damper rod for bends or damage
- Damper unit for deformation or oil leaks
- Rubber bumper for wear or damage

Inspect all the other parts for wear or damage.
If necessary, replace the shock absorber as an assembly.

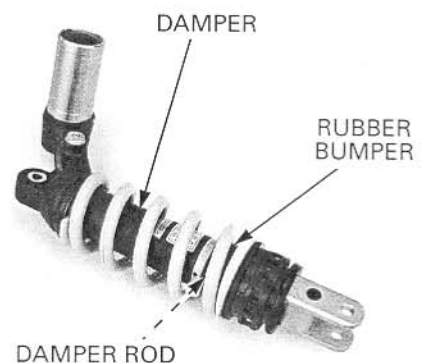

REAR WHEEL/SUSPENSION

SPHERICAL BEARING REPLACEMENT

Remove the dust seals.

Remove the stopper ring.

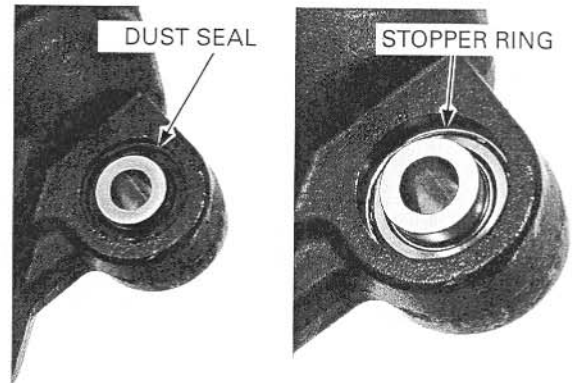

Prepare the following items for the spherical bearing removal.

- Metal pipe for the base holder: I.D. 27 mm, or other suitable collar.
- Metal pipe for the driver: I.D. 17 mm, O.D. 23 mm X 51 mm length, or other suitable collar.

Press the spherical bearing out of the shock absorber upper mount using the above items.

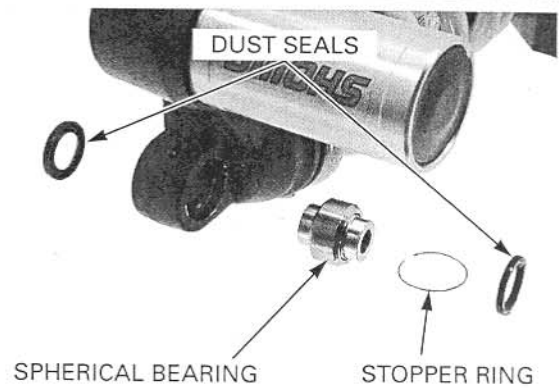
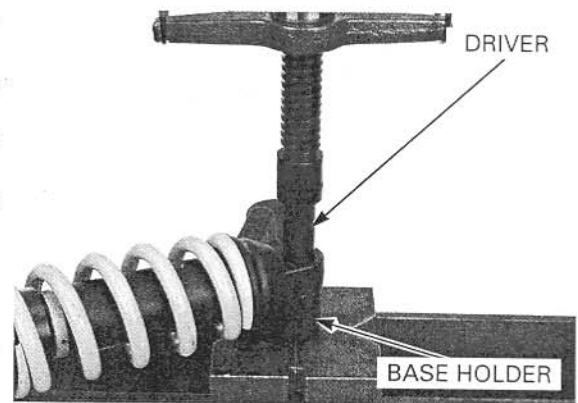

Press a new spherical bearing into the upper mount from the left side using the suitable collar and special tool.

TOOLS:

Spherical bearing driver 07HMF-KS60100

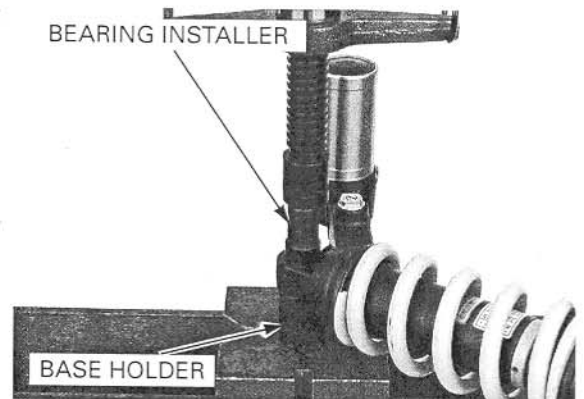

REAR WHEEL/SUSPENSION

Install a new stopper ring into the groove of the rear shock absorber upper mount securely.

Apply grease to the new dust seal lips and install them into the upper mount.

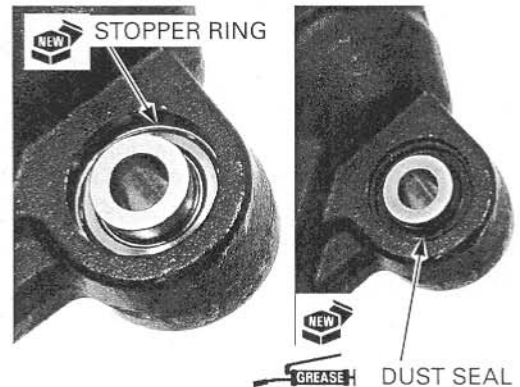

SHOCK ABSORBER DISPOSAL PROCEDURE

Remove the damper reservoir cap.

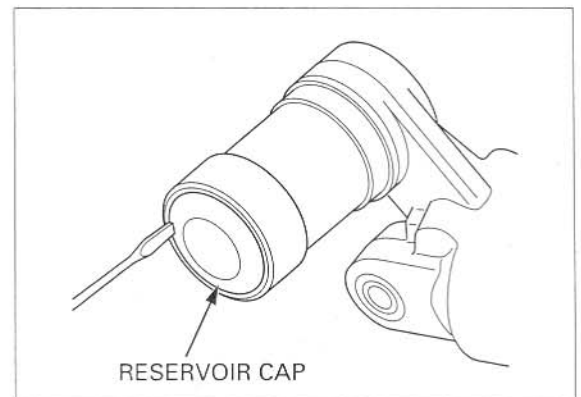

Do not remove the valve core until pressure is released.

Put on safety glasses, then release the nitrogen from the reservoir by depressing the valve core.

- Point the valve away from you to prevent debris getting in your eyes.
- Before disposal of the shock absorber, release the nitrogen by pressing the valve core. Then remove the valve from the shock absorber reservoir.

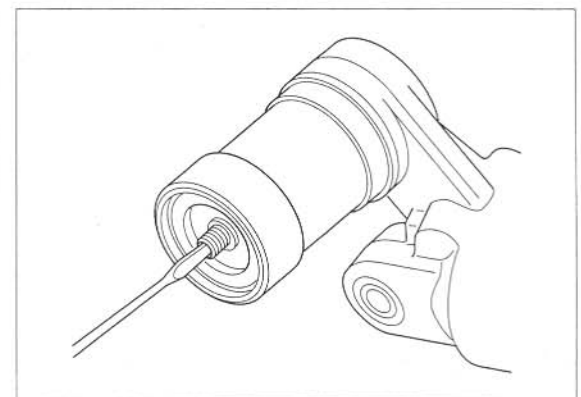

INSTALLATION

Set the shock absorber onto the shock arm with the rebound damping adjuster facing left.

Install the lower mounting bolt.

Tighten the lower mounting nut to the specified torque.

TORQUE: 44 N·m (4.5 kgf·m, 33 lbf·ft)

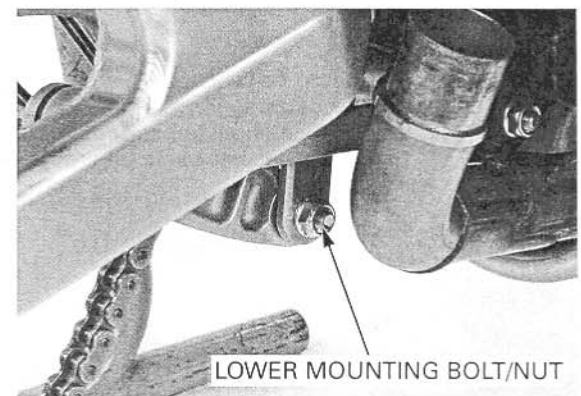

REAR WHEEL/SUSPENSION

Install the rear shock absorber upper mounting bracket and four bolts.
Tighten the bolts to the specified torque.

TORQUE: 44 N·m (4.5 kgf·m, 33 lbf·ft)

Install the upper mounting bolt.
Tighten the upper mounting nut to the specified torque.

TORQUE: 44 N·m (4.5 kgf·m, 33 lbf·ft)

Install the following:

- Rear wheel (page 15-14)
- Muffler (page 3-22)
- Rear fender (page 3-18)
- EVAP canister (california type only) (page 4-20)

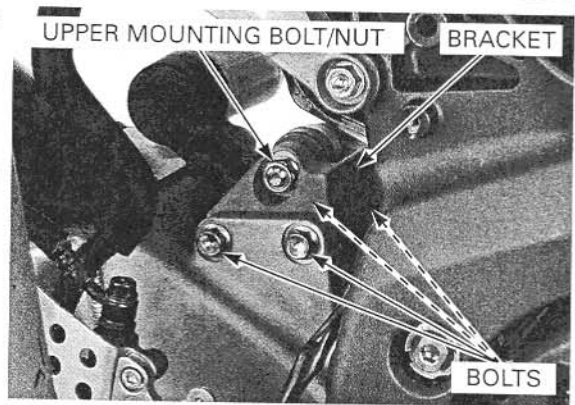

SUSPENSION LINKAGE

REMOVAL

Support the motorcycle using a hoist or equivalent, and raise the rear wheel off the ground.

Remove the shock absorber (page 15-15).

Remove the following:

- Shock arm bolt/nut (shock link side)
- Shock arm bolt/nut (swingarm side)
- Shock arm
- Shock link bolt/nut (frame side)
- Shock link

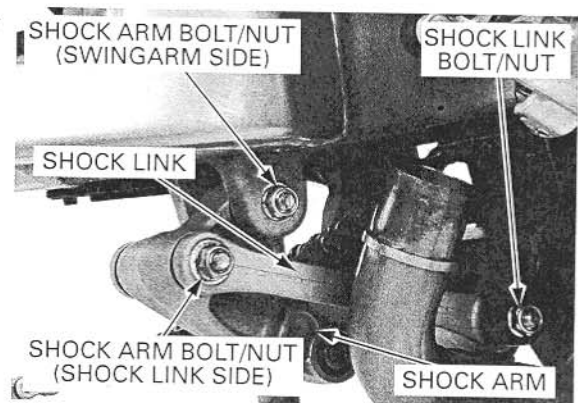

Remove the pivot collar and dust seals from the shock link.

Check the dust seals and pivot collar for wear, damage or fatigue.

Check the needle bearings for damage or loose fit.

Check the shock link for cracks or damage.

If the needle bearings are damaged, replace them.

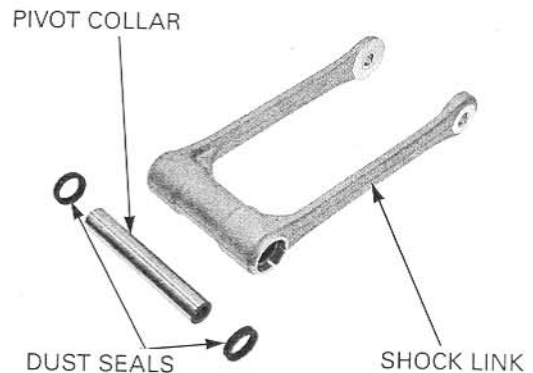

Remove the following:

- Pivot collars
- Thrust washers
- Dust seals
- Side collars

Check the dust seals, thrust washers and collars for wear, damage or fatigue.

Check the needle bearings for damage or loose fit.

Check the shock arm for cracks or damage.

If the needle bearings are damaged, replace them.

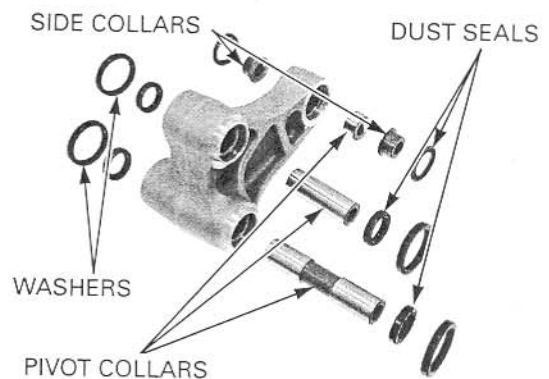

BEARING REPLACEMENT

SHOCK LINK NEEDLE BEARING

Remove the pivot collar and dust seals.

Remove the needle bearings from the shock link using the special tools.

TOOLS:

Bearing remover, 17 mm	07936-3710300
Remover handle	07936-3710100
Remover weight	07741-0010201 or 07936-371020A

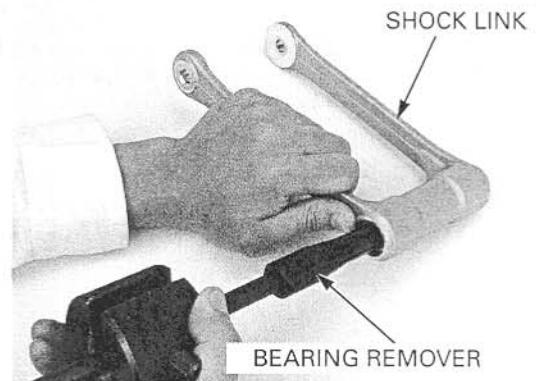

Press the needle bearing into the shock link with the marked side facing out.

Pack the new needle bearings with multi-purpose grease.

Press the new needle bearings into the shock link so that the needle bearing surface is lower 4.8 – 5.2 mm (0.19 – 0.20 in) from the end of the shock link using the special tools.

TOOLS:

Driver	07749-0010000
Attachment, 22 X 24 mm	07746-0010800
Pilot, 17 mm	07746-0040400

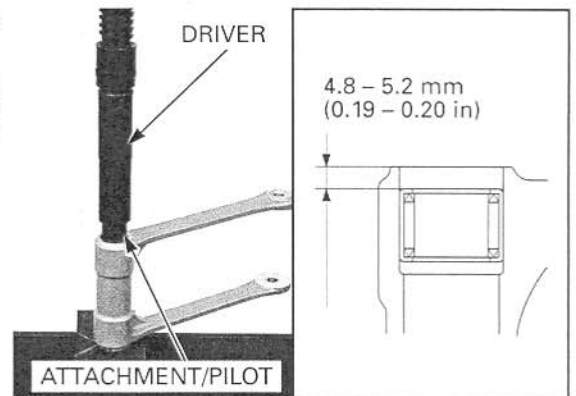

SHOCK ARM NEEDLE BEARING

Remove the pivot collars, thrust washers, side collars and dust seals.

Press the needle bearings (shock link side, swing-arm side) out of the shock arm using the special tools and a hydraulic press.

TOOLS:

Driver	07949-3710001
Attachment, 22 X 24 mm	07746-0010800
Pilot, 17 mm	07746-0040400

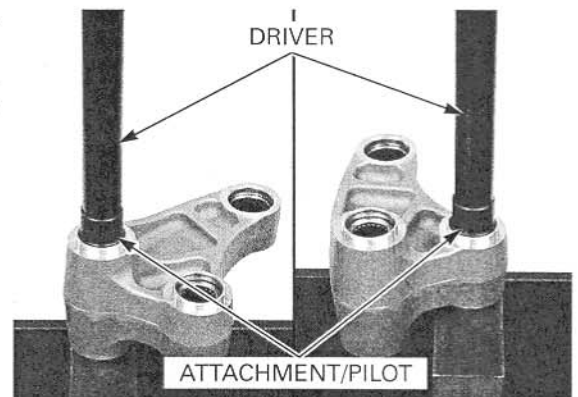

Press the needle bearing (shock absorber side) out of the shock arm using the special tools and a hydraulic press.

TOOLS:

Driver	07949-3710001
Attachment, 24 X 26 mm	07746-0010700
Pilot, 22 mm	07746-0041000

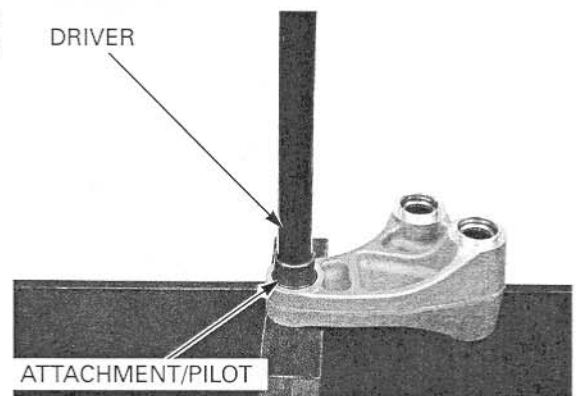

REAR WHEEL/SUSPENSION

Press the needle bearing into the shock arm with the marked side facing out.

Pack the new needle bearings with multi-purpose grease.

Press the new needle bearings into the shock link side pivot with the special tools and a hydraulic press so that the needle bearing surface is lower 4.8 – 5.2 mm (0.19 – 0.20 in) from the end of the shock arm surface.

TOOLS:

Driver	07749-0010000
Attachment, 22 X 24 mm	07746-0010800
Pilot, 17 mm	07746-0040400

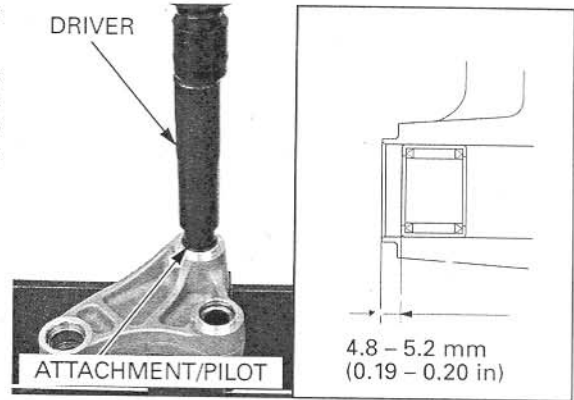

Press the needle bearing into the shock arm with the marked side facing out.

Pack the new needle bearings with multi-purpose grease.

Press the new needle bearings into the swingarm side pivot with the special tools and a hydraulic press so that the needle bearing surface is lower 4.8 – 5.2 mm (0.19 – 0.20 in) from the end of the shock arm surface.

TOOLS:

Driver	07749-0010000
Attachment, 22 X 24 mm	07746-0010800
Pilot, 17 mm	07746-0040400

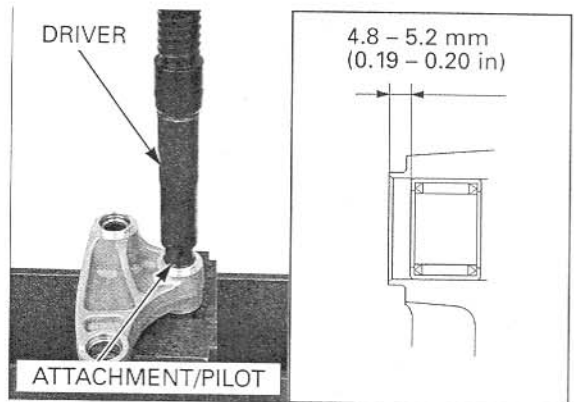

Pack the new needle bearing with multi-purpose grease.

Press the new needle bearing into the shock absorber side pivot with the special tools and a hydraulic press so that the needle bearing surface is lower 5.35 – 5.65 mm (0.211 – 0.222 in) from the end of the shock arm surface.

TOOLS:

Driver	07749-0010000
Attachment, 24 X 26 mm	07746-0010700
Pilot, 22 mm	07746-0041000

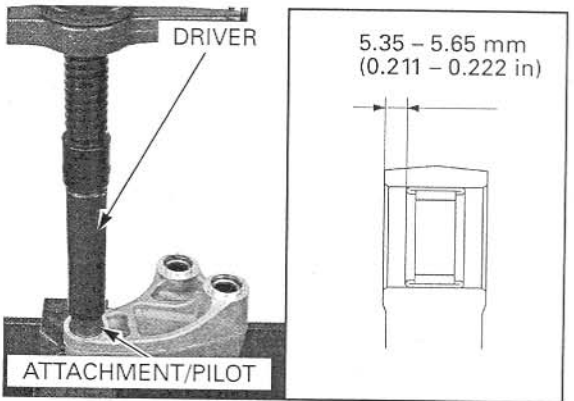

INSTALLATION

Apply multi-purpose grease NLGI No.2 (molybdenum disulfide additive) to the dust seal lips, collars and needle bearings.

- Make sure the needle bearing rollers of shock absorber side are in position before installing.
 - Number of needle rollers: 27

Install the pivot collars, side collars, dust seals and thrust washers to the shock arm.

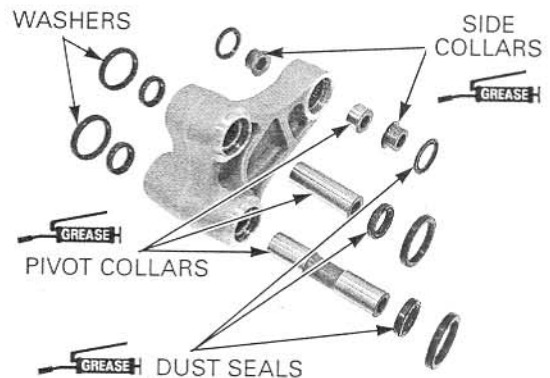

REAR WHEEL/SUSPENSION

Apply multi-purpose grease NLGI No.2 (molybdenum disulfide additive) to the dust seal lips, pivot collar and needle bearings.
Install the pivot collar and dust seals to the shock link.

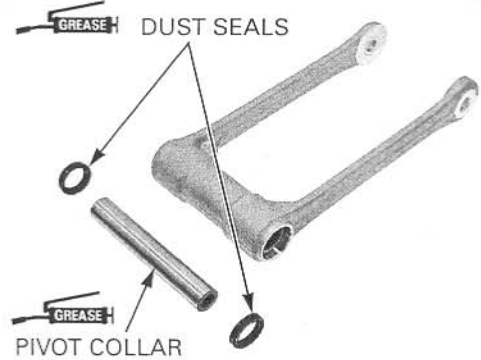

Apply oil to the shock arm nut threads and flange surface.

Temporarily install the following:

- Shock link
- Shock link bolt/nut (frame side)
- Shock arm
- Shock arm bolt/nut (swingarm side)
- Shock arm bolt/nut (shock link side)

Tighten the nuts to the specified torque.

TORQUE:

- Shock link-to-frame pivot nut:
44 N·m (4.5 kgf·m, 33 lbf·ft)
- Shock arm-to-shock link nut:
44 N·m (4.5 kgf·m, 33 lbf·ft)
- Shock arm-to-swingarm nut:
44 N·m (4.5 kgf·m, 33 lbf·ft)

Install the shock absorber (page 15-17).

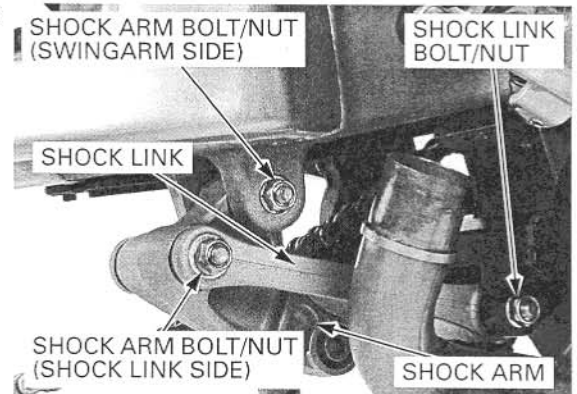

SWINGARM

REMOVAL

Remove the following:

- Rear wheel (page 15-8)
- Shock absorber (page 15-15)

California type only Remove the EVAP canister (page 4-20).

Remove the bolt and rear brake hose guide from the swingarm.

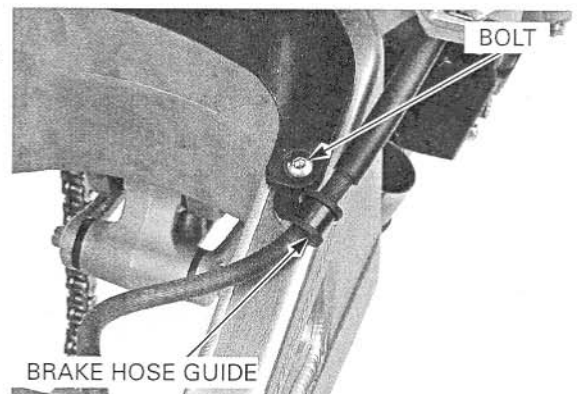

REAR WHEEL/SUSPENSION

Remove the shock arm bolt/nut (swingarm side).

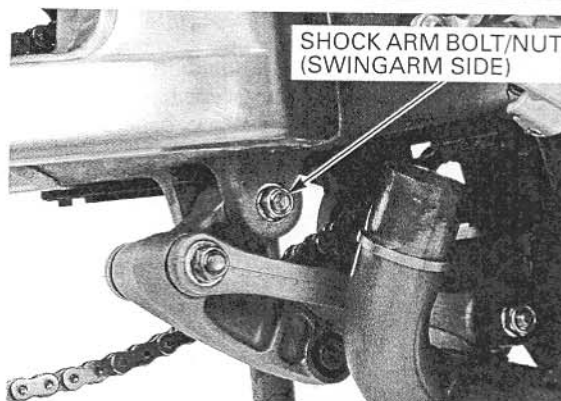

Remove the bolt and disconnect the gearshift arm from the gearshift spindle.

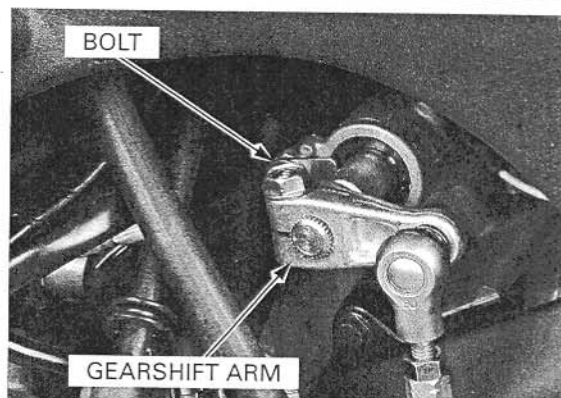

Remove the bolts, spacer and drive sprocket cover.

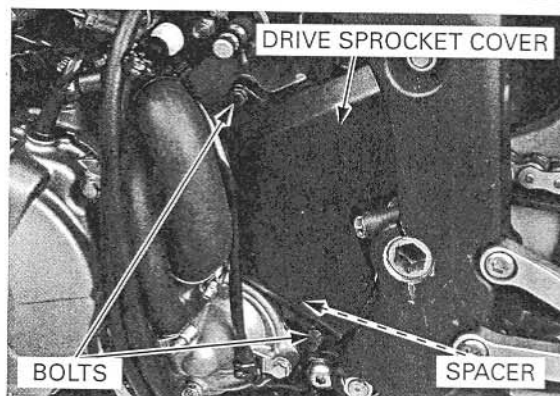

Remove the bolt, washer and drive sprocket.

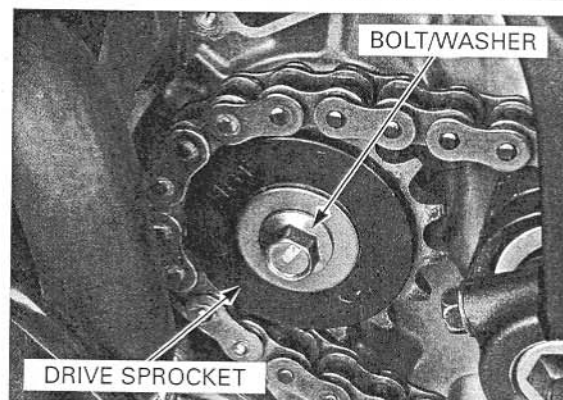

REAR WHEEL/SUSPENSION

Loosen the swingarm right pivot pinch bolt and remove the swingarm pivot nut.

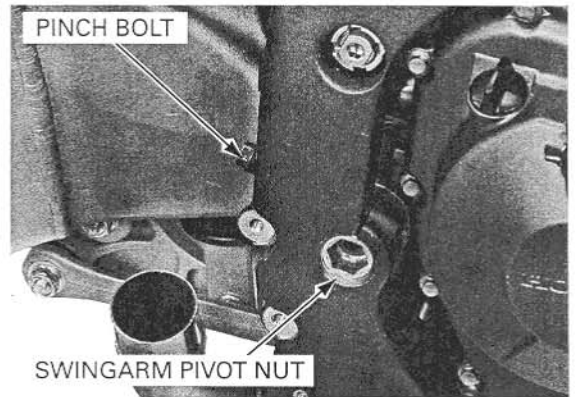

Loosen the swingarm left pivot pinch bolt. Remove the pivot shaft and the swingarm.

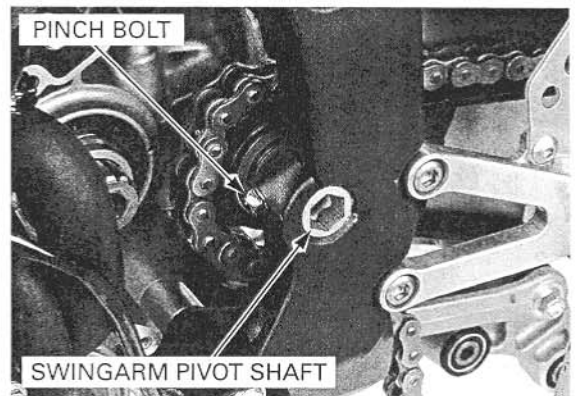

DISASSEMBLY/INSPECTION

Remove the two bolts and rear inner fender.

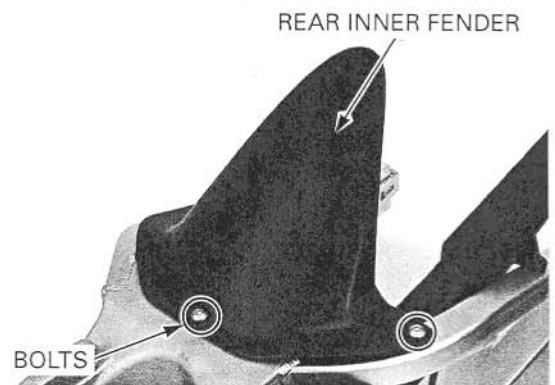

Remove the three bolts and drive chain guard.

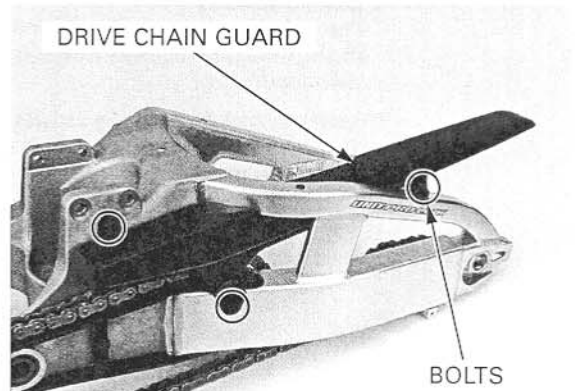

REAR WHEEL/SUSPENSION

Remove the three bolts, washer, collars and drive chain slider.

Check the drive chain slider for wear or damage.

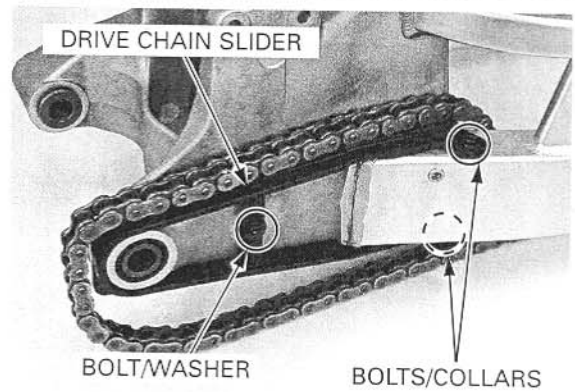

Remove the pivot collar and dust seals from the swingarm left side pivot.

Check the dust seals and pivot collar for damage or fatigue.

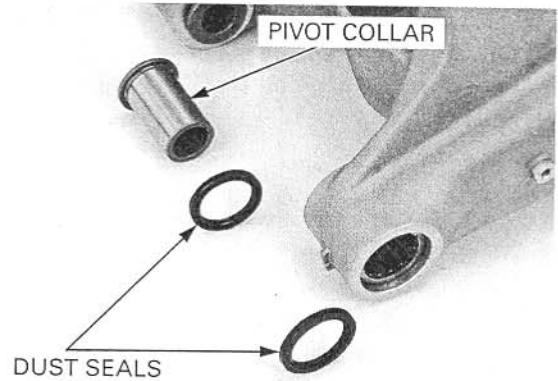

Remove the pivot collar and dust seals from the swingarm right side pivot.

Check the dust seals and pivot collar for damage or fatigue.

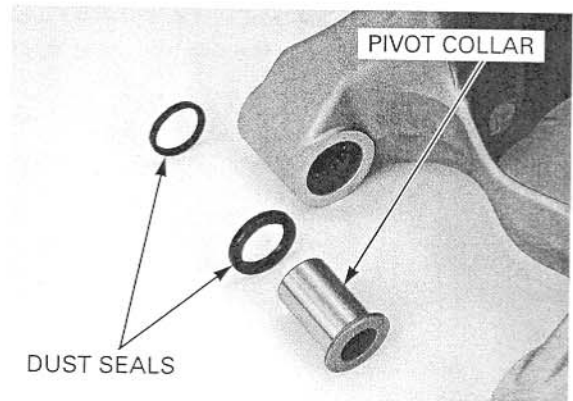

Turn the inner race of right side pivot ball bearing with your finger.

The bearing should turn smoothly and quietly. Also check that the bearing outer race fits tightly in the swingarm pivot.

Remove and discard the bearing if the races do not turn smoothly and quietly, or if they fit loosely in the swingarm pivot.

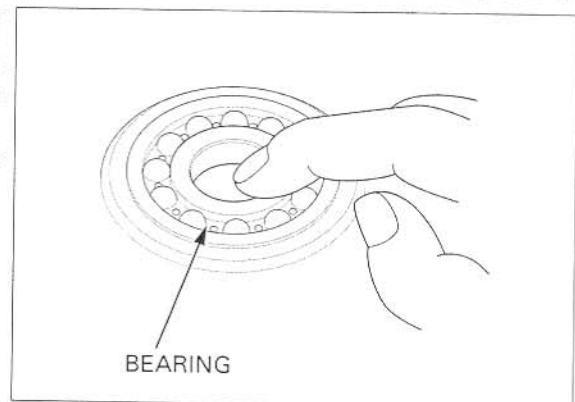

REAR WHEEL/SUSPENSION

PIVOT BEARING REPLACEMENT

Remove the snap ring from the swingarm right side pivot.

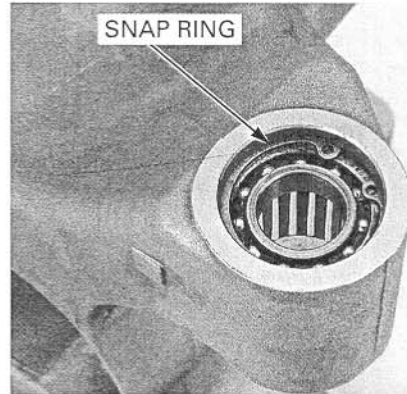

Remove the right side pivot ball bearing using the special tools.

TOOLS:

Bearing remover handle	07936-3710100
Bearing remover, 20 mm	07936-3710600
Remover weight	07741-0010201 or 07936-371020A



Remove the left side pivot needle bearing from the swingarm pivot using the special tools.

TOOLS:

Driver	07949-3710001
Attachment, 37 mm	07ZMD-MBW0200
Pilot, 28 mm	07746-0041100
or	
Driver shaft	07946-MJ00100
Attachment, 37 mm	07ZMD-MBW0200
or	
Driver shaft	07946-MJ00100
Needle bearing remover	07HMC-MR70100

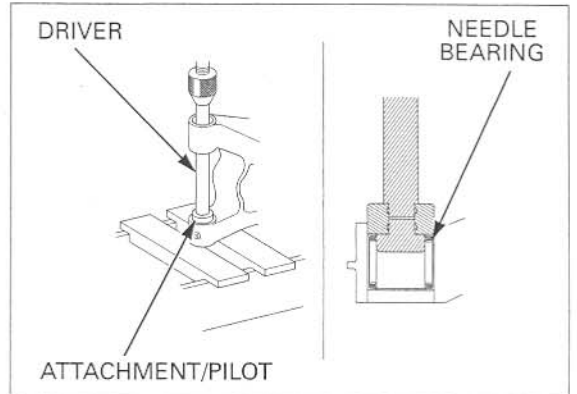

Press the right side pivot needle bearing out using the special tools and a hydraulic press.

TOOLS:

Driver	07949-3710001
Attachment, 34 mm	07ZMD-MBW0100
Pilot, 28 mm	07746-0041100
or	
Driver shaft	07946-MJ00100
Attachment, 34 mm	07ZMD-MBW0100

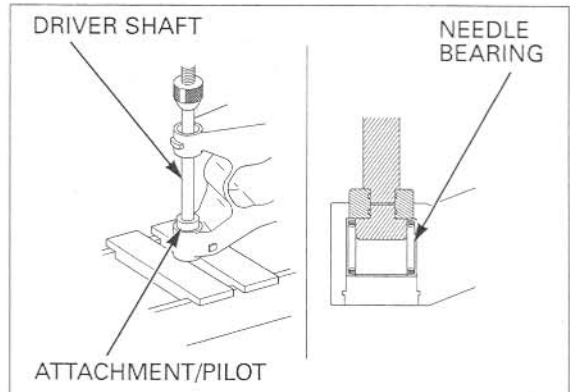

REAR WHEEL/SUSPENSION

Press the needle bearing into the swingarm with the marked side facing out.

Pack a new needle bearing with grease. Press the needle bearing into the swingarm right pivot until it seats using the special tools and a hydraulic press.

TOOLS:

Driver	07749-0010000
Attachment, 37 mm	07ZMD-MBW0200
Pilot, 28 mm	07746-0041100

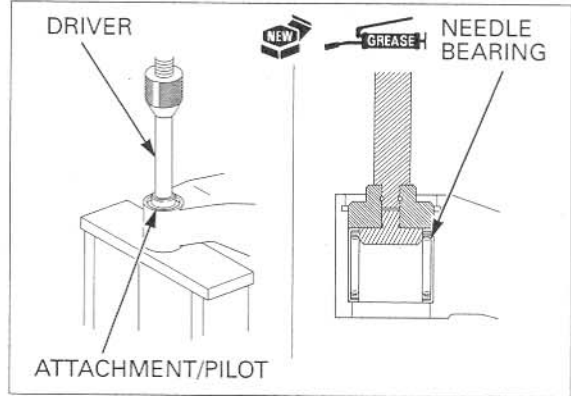

Press the radial ball bearing into the swingarm with the marked side facing out.

Press the new radial ball bearing in using the special tools and a hydraulic press.

TOOLS:

Driver	07749-0010000
Attachment, 37 X 40 mm	07746-0010200
Pilot, 20 mm	07746-0040500

or

Driver	07749-0010000
Attachment, 37 mm	07ZMD-MBW0200
Pilot, 20 mm	07746-0040500

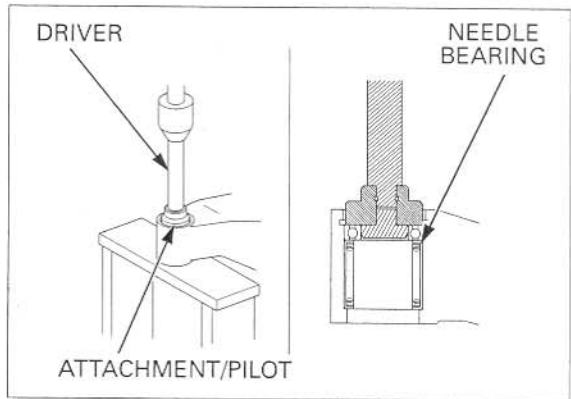

Install the snap ring into the groove securely.

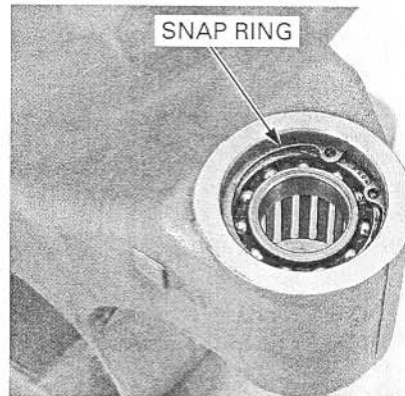

Press the needle bearing into the swingarm with the marked side facing out.

Press a new left side pivot needle bearing into the swingarm pivot so that the needle bearing surface is 5.0 – 6.0 mm (0.20 – 0.24 in) below the end of the swingarm pivot surface using the special tools and a hydraulic press.

TOOLS:

Driver	07749-0010000
Attachment, 37 X 40 mm	07746-0010200
Pilot, 28 mm or	07746-0041100

or

Driver	07749-0010000
Attachment, 37 mm	07ZMD-MBW0200
Pilot, 28 mm	07746-0041100

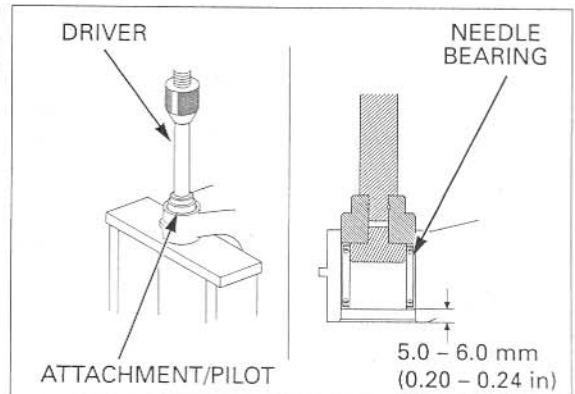

ASSEMBLY

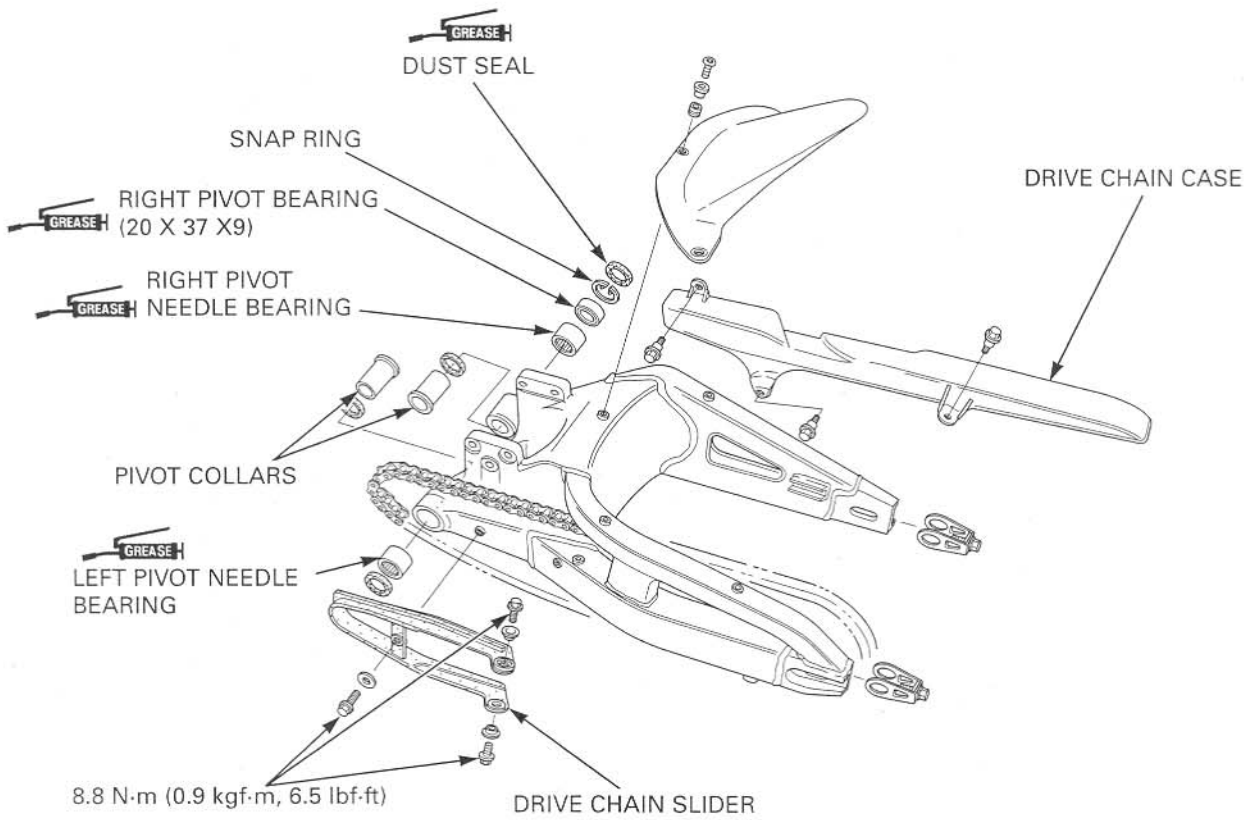

Apply grease to the dust seal lips, then install the dust seals and pivot collar into the right swingarm pivot.

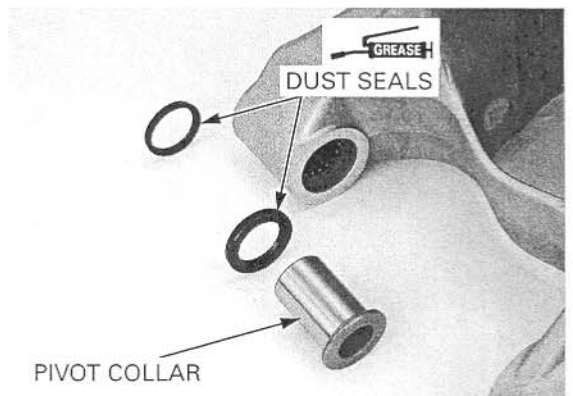

Apply grease to the dust seal lips, then install the dust seals and pivot collar into the left swingarm pivot.

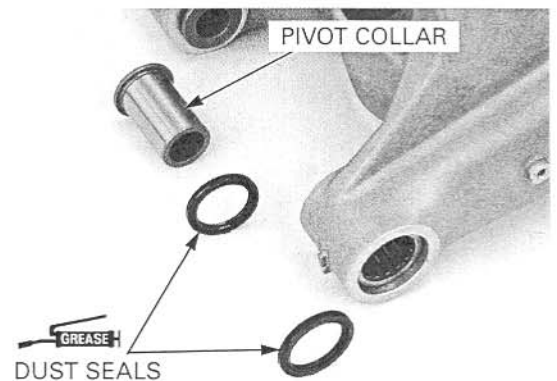

REAR WHEEL/SUSPENSION

Install the drive chain slider aligning its slit with the boss on the swingarm.

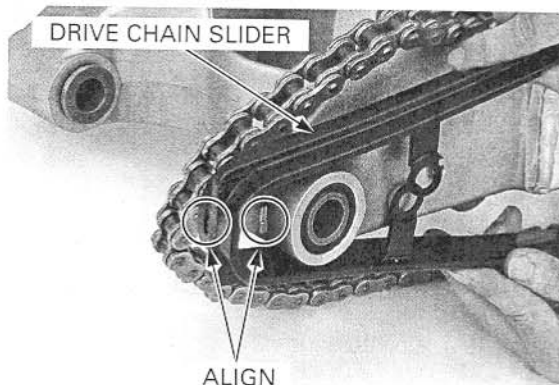

Install and tighten the washer, collars and new drive chain slider mounting bolts to the specified torque.

TORQUE: 8.8 N·m (0.9 kgf·m, 6.5 lbf·ft)

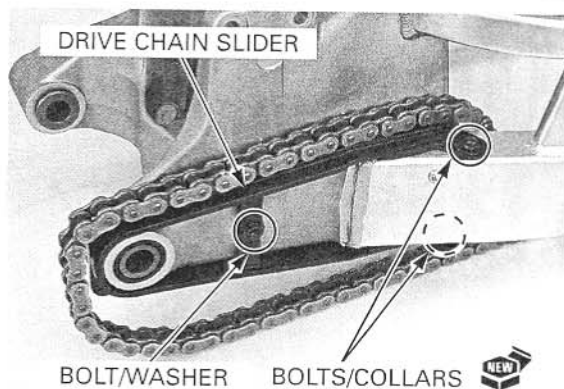

Install the drive chain guard, three bolts and tighten the bolts securely.

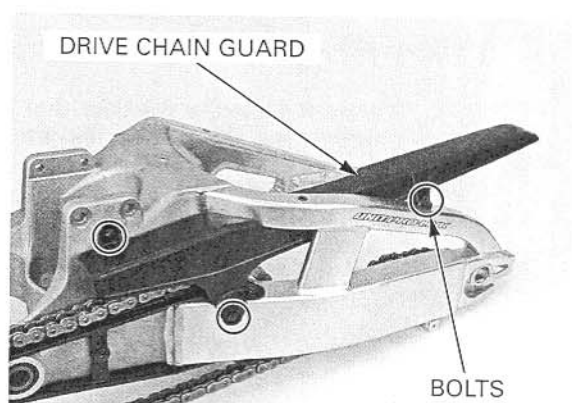

Install the rear inner fender and bolts.

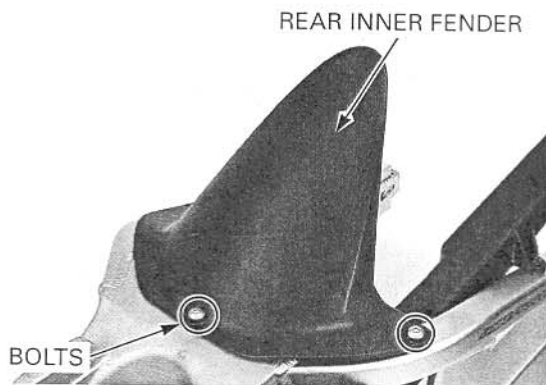

INSTALLATION

Apply a thin coat of grease to the swingarm pivot bolt sliding surface.

Install the swingarm between the engine and frame.

Install the swingarm pivot shaft from the left side through the frame, swingarm pivot and engine.

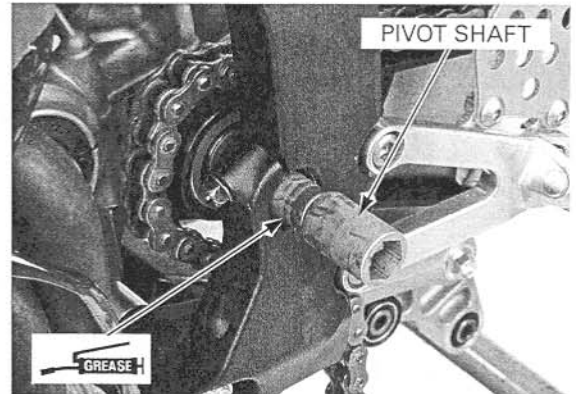

Install and tighten the swingarm pivot nut to the specified torque.

TORQUE: 93 N·m (9.5 kgf·m, 69 lbf·ft)

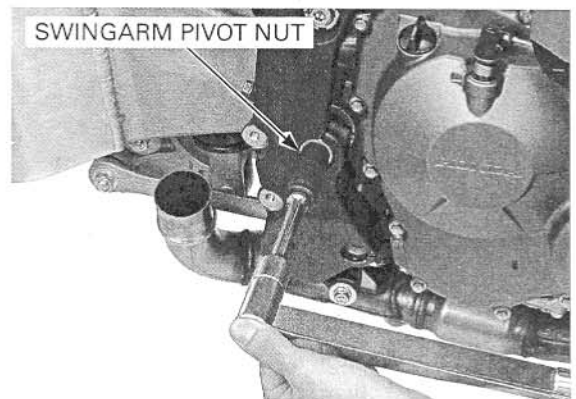

Tighten the right swingarm pivot pinch bolt to the specified torque.

TORQUE: 27 N·m (2.7 kgf·m, 20 lbf·ft)

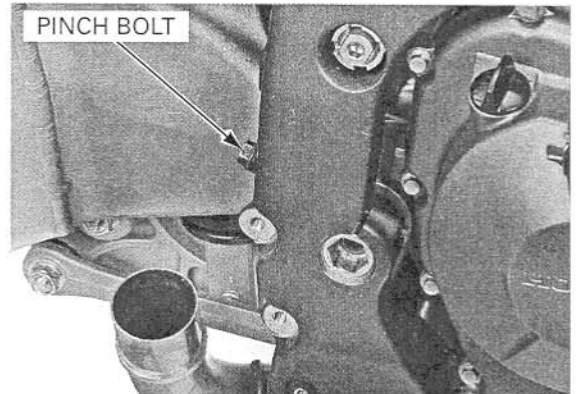

Tighten the left swingarm pivot pinch bolt to the specified torque.

TORQUE: 27 N·m (2.7 kgf·m, 20 lbf·ft)

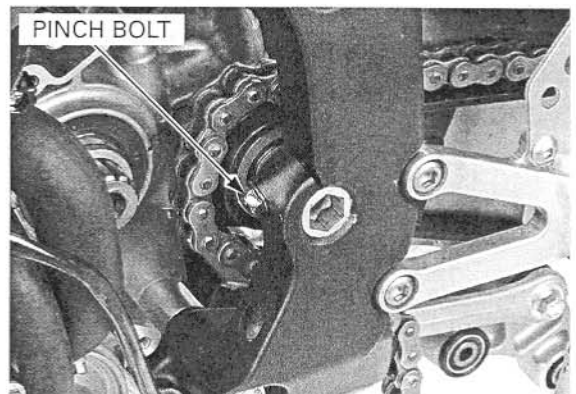

REAR WHEEL/SUSPENSION

Install the drive sprocket with its marks facing out.

Install the washer and special bolt, then tighten the bolt to the specified torque.

TORQUE: 54 N·m (5.5 kgf·m, 40 lbf·ft)

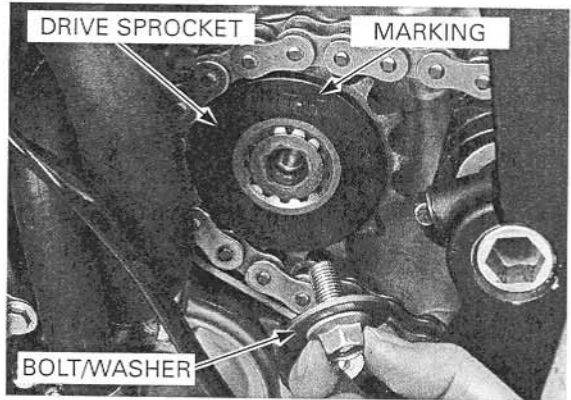

Install the spacer and drive sprocket cover, tighten the bolts securely.

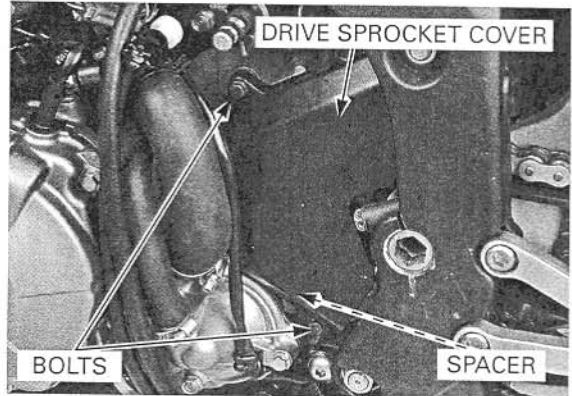

Install the gearshift arm aligning its slit with the punch mark on the gearshift spindle.

Tighten the bolt securely.

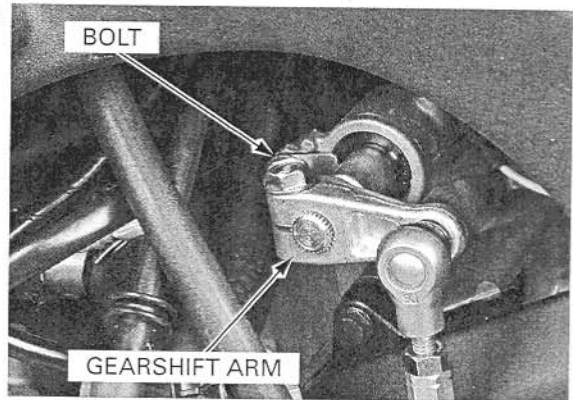

Install the shock arm bolt/nut (swingarm side) and tighten the nut to the specified torque.

TORQUE: 44 N·m (4.5 kgf·m, 33 lbf·ft)

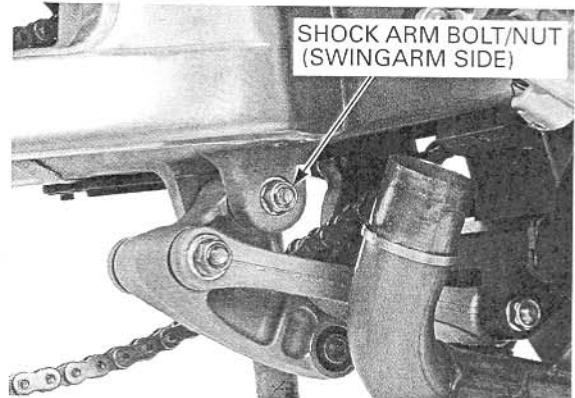

REAR WHEEL/SUSPENSION

Install the rear brake hose guide, bolt onto the swingarm and tighten the bolt securely.

Install the following:

- Shock absorber (page 15-17)
- Rear wheel (page 15-14)

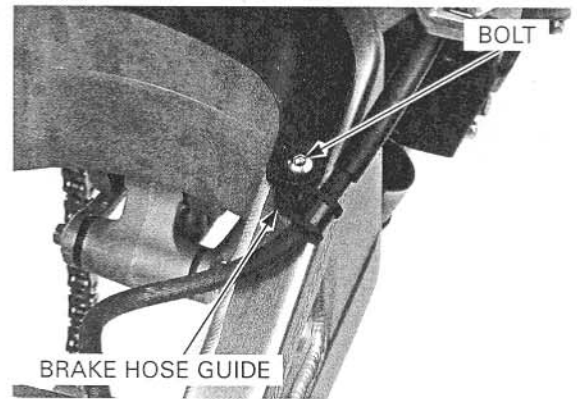

16. HYDRAULIC BRAKE

COMPONENT LOCATION	16-2	FRONT MASTER CYLINDER.....	16-13
SERVICE INFORMATION	16-4	REAR MASTER CYLINDER	16-18
TROUBLESHOOTING.....	16-5	FRONT BRAKE CALIPERS.....	16-22
BRAKE FLUID REPLACEMENT/ AIR BLEEDING	16-6	REAR BRAKE CALIPER.....	16-26
BRAKE PAD/DISC.....	16-9	BRAKE PEDAL	16-29

HYDRAULIC BRAKE

COMPONENT LOCATION

FRONT:

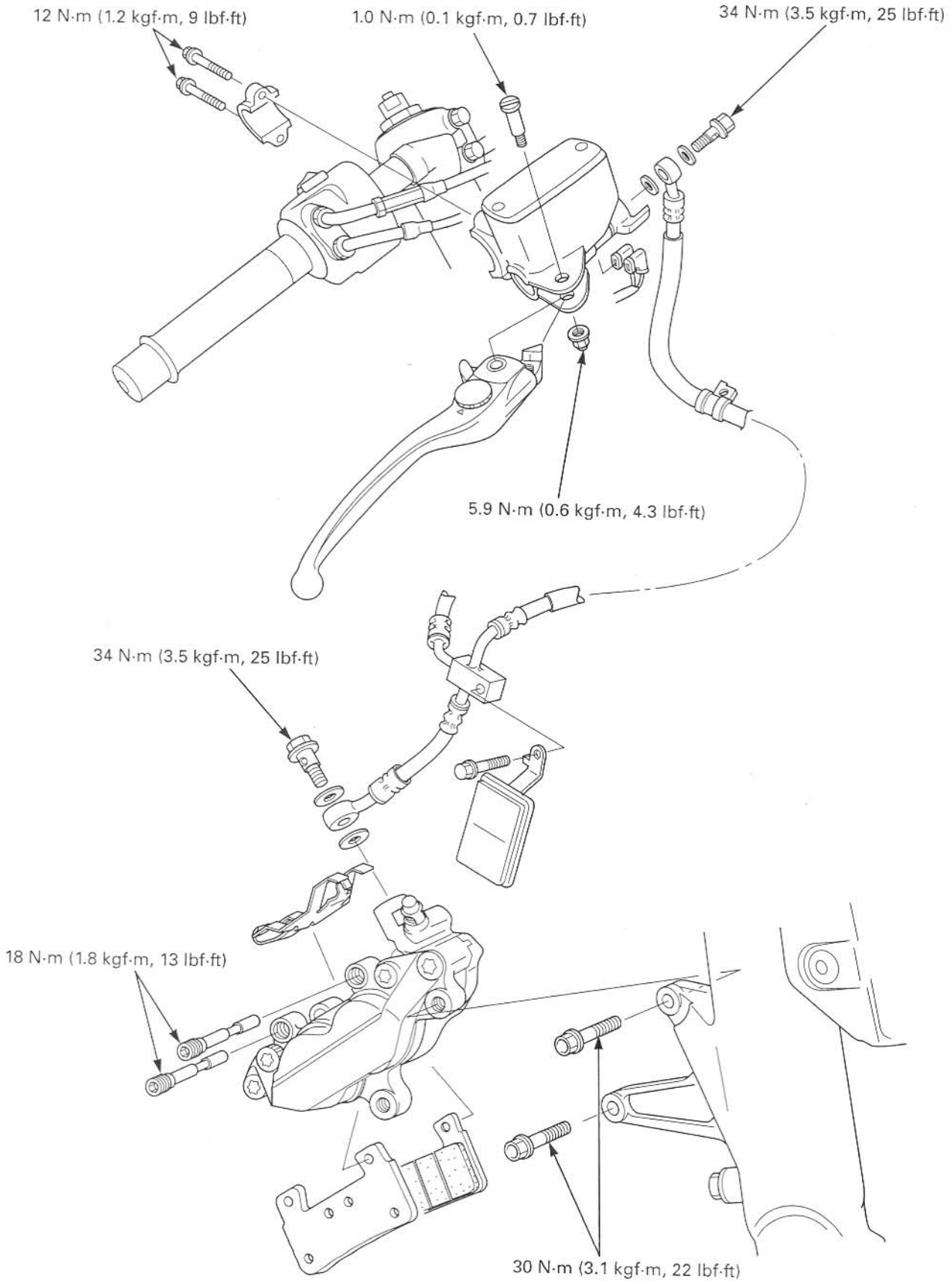

REAR:

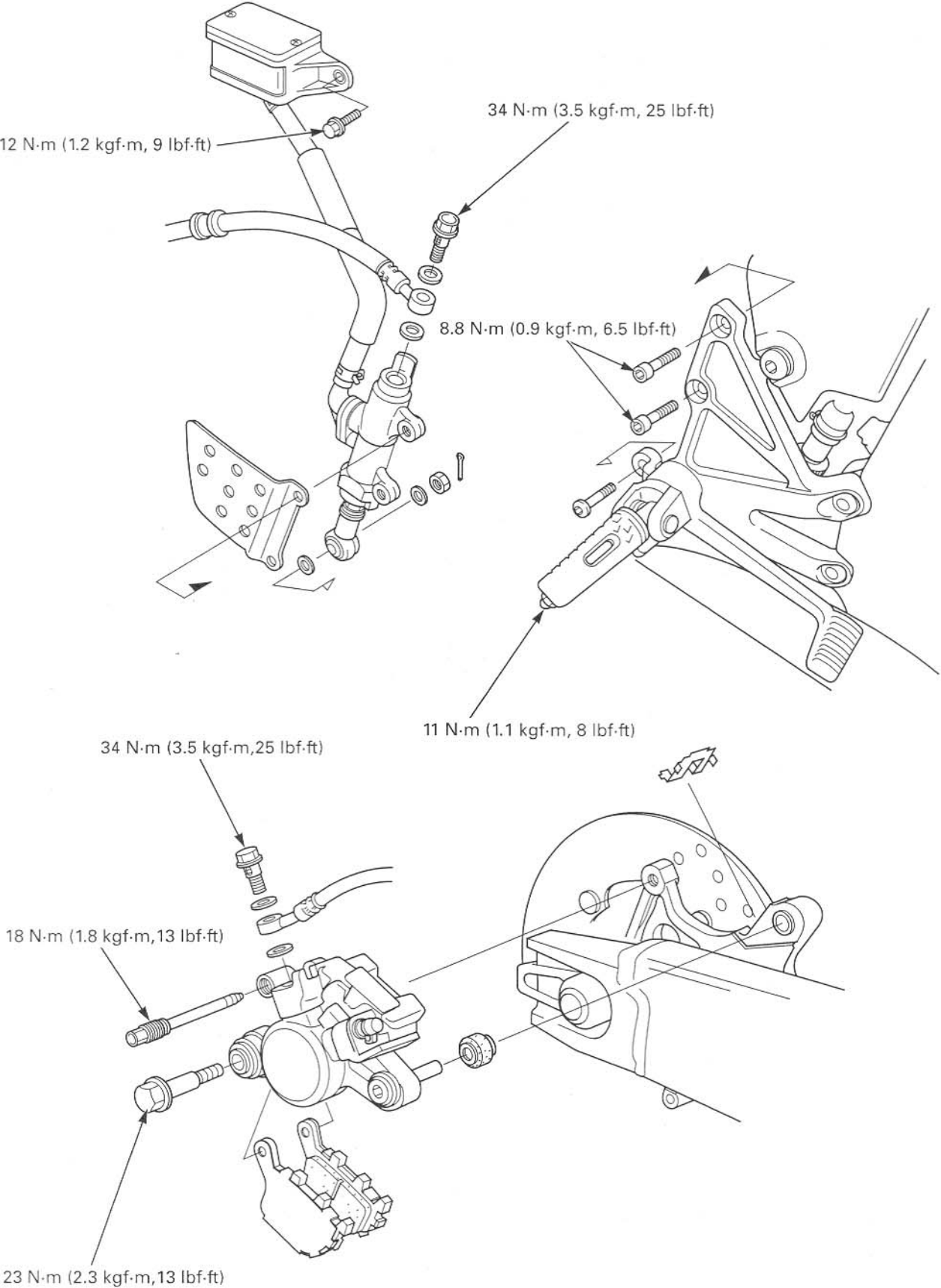

HYDRAULIC BRAKE

SERVICE INFORMATION

GENERAL

⚠ CAUTION

Frequent inhalation of brake pad dust, regardless of material composition, could be hazardous to your health.

- Avoid breathing dust particles.
- Never use an air hose or brush to clean brake assemblies. Use an OSHA-approved vacuum cleaner.

NOTICE

Spilled brake fluid will severely damage instrument lenses and painted surfaces. It is also harmful to some rubber parts. Be careful whenever you remove the reservoir cap; make sure the reservoirs are horizontal first.

- A contaminated brake disc or pad reduces stopping power. Discard contaminated pads and clean a contaminated disc with a high quality brake degreasing agent.
- Check the brake system by applying the brake lever or pedal after the air bleeding.
- Never allow contaminants (dirt, water, etc.) to get into an open reservoir.
- Once the hydraulic system has been opened, or if the brake feels spongy, the system must be bled.
- Always use fresh DOT 4 brake fluid from a sealed container when servicing the system. Do not mix different types of fluid; they may not be compatible.
- Always check brake operation before riding the motorcycle.

SPECIFICATIONS

Unit: mm (in)

ITEM		STANDARD	SERVICE LIMIT	
Front	Specified brake fluid	Honda DOT 4 Brake Fluid	-	
	Brake disc thickness	4.4 – 4.6 (0.17 – 0.18)	3.5 (0.14)	
	Brake disc runout	-	0.30 (0.012)	
	Master cylinder I.D.	17.460 – 17.503 (0.6874 – 0.6891)	17.515 (0.6896)	
	Master piston O.D.	17.321 – 17.367 (0.6819 – 0.6837)	17.309 (0.6815)	
	Caliper cylinder I.D.	A	32.030 – 32.080 (1.2610 – 1.2630)	32.092 (1.2635)
		B	30.230 – 30.280 (1.1902 – 1.1921)	30.292 (1.1926)
	Caliper piston O.D.	A	31.948 – 31.998 (1.2578 – 1.2598)	31.940 (1.2574)
B		30.082 – 30.115 (1.1843 – 1.1856)	30.074 (1.1840)	
Rear	Specified brake fluid	Honda DOT 4 Brake Fluid	-	
	Brake pedal height	75 (3.0)	-	
	Brake disk thickness	4.8 – 5.2 (0.19 – 0.20)	4.0 (0.16)	
	Brake disc runout	-	0.30 (0.012)	
	Master cylinder I.D.	15.870 – 15.913 (0.6248 – 0.6265)	15.925 (0.6270)	
	Master piston O.D.	15.827 – 15.854 (0.6231 – 0.6242)	15.815 (0.6226)	
	Caliper cylinder I.D.	38.180 – 38.230 (1.5031 – 1.5051)	38.24 (1.506)	
	Caliper piston O.D.	38.098 – 38.148 (1.4999 – 1.5019)	38.09 (1.500)	

TORQUE VALUES

Front master cylinder reservoir cap screw	1.5 N·m (0.15 kgf·m, 1.1 lbf·ft)
Front brake lever pivot bolt	1.0 N·m (0.1 kgf·m, 0.7 lbf·ft)
Front brake lever pivot nut	5.9 N·m (0.6 kgf·m, 4.3 lbf·ft)
Front brake light switch screw	1.0 N·m (0.1 kgf·m, 0.7 lbf·ft)
Front master cylinder holder bolt	12 N·m (1.2 kgf·m, 9 lbf·ft)
Front brake caliper assembly torx bolt	23 N·m (2.3 kgf·m, 17 lbf·ft)
Front brake caliper mounting bolt	30 N·m (3.1 kgf·m, 22 lbf·ft)
Rear master cylinder reservoir cap screw	1.5 N·m (0.15 kgf·m, 1.1 lbf·ft)
Rear master cylinder push rod joint nut	18 N·m (1.8 kgf·m, 13 lbf·ft)
Rear master cylinder mounting bolt	8.8 N·m (0.9 kgf·m, 6.5 lbf·ft)
Rear brake reservoir mounting bolt	12 N·m (1.2 kgf·m, 9 lbf·ft)
Rear brake caliper mounting bolt	23 N·m (2.3 kgf·m, 17 lbf·ft)
Rear brake caliper slide pin bolt	27 N·m (2.8 kgf·m, 20 lbf·ft)
Front brake caliper pad pin	18 N·m (1.8 kgf·m, 13 lbf·ft)
Rear brake caliper pad pin	18 N·m (1.8 kgf·m, 13 lbf·ft)
Brake hose oil bolt	34 N·m (3.5 kgf·m, 25 lbf·ft)
Front brake hose clamp bolt	12 N·m (1.2 kgf·m, 9 lbf·ft)
Front brake hose 3-way joint bolt	12 N·m (1.2 kgf·m, 9 lbf·ft)

Apply a locking agent to the threads
ALOC bolt: replace with a new one

HYDRAULIC BRAKE

Rear brake reservoir hose joint screw	1.5 N·m (0.15 kgf·m, 1.1 lbf·ft)	Apply a locking agent to the threads
Brake caliper bleed valve	5.9 N·m (0.6 kgf·m, 4.3 lbf·ft)	
Driver footpeg bolt	44 N·m (4.5 kgf·m, 33 lbf·ft)	ALOC bolt: replace with a new one
Driver footpeg cap bolt	11 N·m (1.1 kgf·m, 8 lbf·ft)	
Driver footpeg bracket socket bolt	37 N·m (3.8 kgf·m, 28 lbf·ft)	

TOOLS

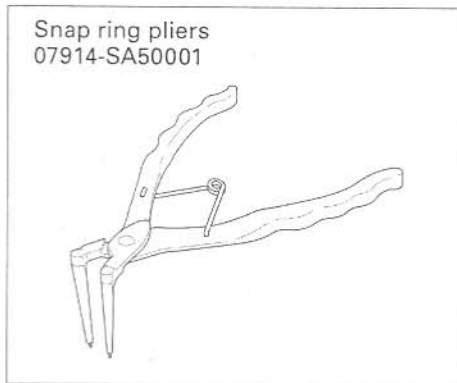

TROUBLESHOOTING

Brake lever/pedal soft or spongy

- Air in hydraulic system
- Leaking hydraulic system
- Contaminated brake pad/disc
- Worn caliper piston seal
- Worn master cylinder piston cups
- Worn brake pad/disc
- Contaminated caliper
- Caliper not sliding properly (rear)
- Low brake fluid level
- Clogged fluid passage
- Warped/deformed brake disc
- Sticking/worn caliper piston
- Sticking/worn master cylinder piston
- Contaminated master cylinder
- Bent brake lever/pedal

Brake lever/pedal hard

- Clogged/restricted hydraulic system
- Sticking/worn caliper piston
- Caliper not sliding properly (rear)
- Clogged/restricted fluid passage
- Worn caliper piston seal
- Sticking/worn master cylinder piston
- Bent brake lever/pedal

Brake drags

- Contaminated brake pad/disc
- Misaligned wheel
- Clogged/restricted brake hose joint
- Warped/deformed brake disc
- Caliper not sliding properly (rear)
- Clogged/restricted hydraulic system
- Sticking/worn caliper piston
- Clogged master cylinder port
- Sticking master cylinder piston

HYDRAULIC BRAKE

BRAKE FLUID REPLACEMENT/ AIR BLEEDING

NOTICE

Spilled fluid can damage painted, plastic, or rubber parts. Place a rag over these parts whenever the system is serviced.

- Do not allow foreign material to enter the system when filling the reservoir.

BRAKE FLUID DRAINING

Remove the upper cowl (page 3-9).

For the front brake, turn the handlebar until the reservoir is parallel to the ground, before removing the reservoir cap.

Remove the screws and reservoir cap.

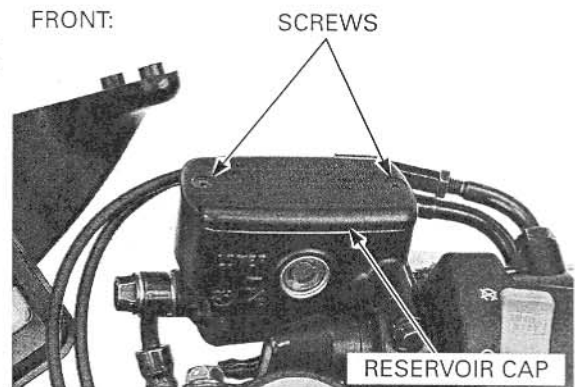

Remove the diaphragm plate, diaphragm and float.

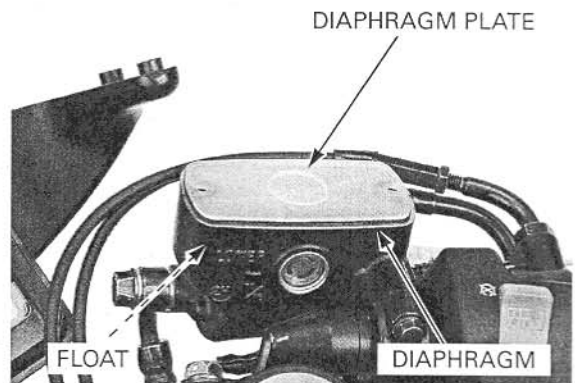

Remove the rear cowl (page 3-5).

For the rear brake, remove the screws and reservoir cap.

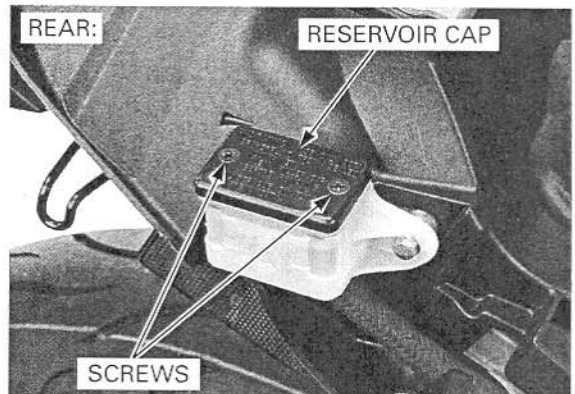

Remove the diaphragm plate and diaphragm.

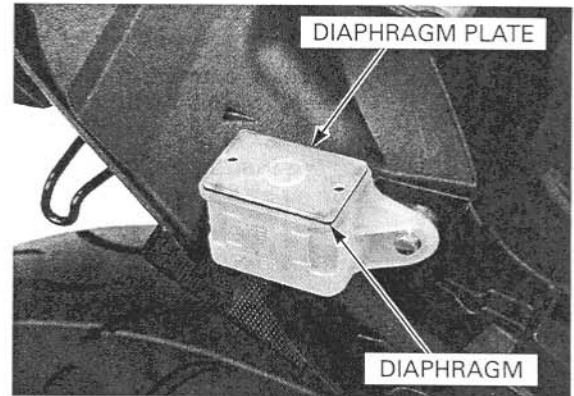

Connect a bleed hose to the caliper bleed valve.

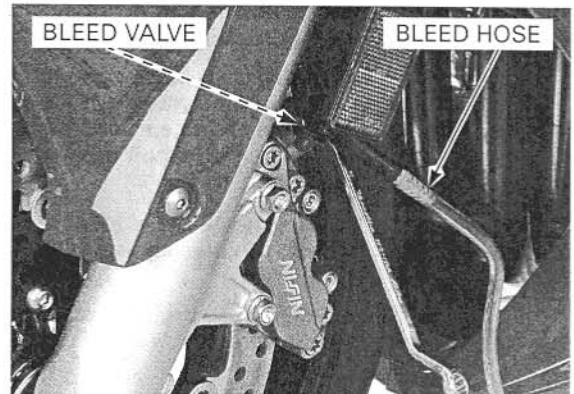

Loosen the bleed valve and pump the brake lever or pedal.
Stop pumping the lever or pedal when no more fluid flows out of the bleed valve.

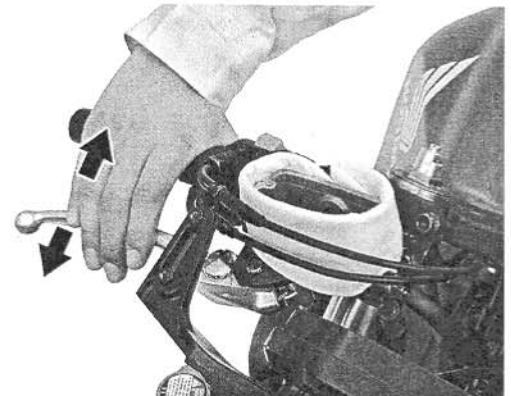

BRAKE FLUID FILLING/AIR BLEEDING

Fill the reservoir with DOT 4 brake fluid from a sealed container.

NOTE:

- Use only DOT 4 brake fluid from a sealed container.
- Do not mix different types of fluid. There are not compatible.

Connect a commercially available brake bleeder to the bleed valve.

Operate the brake bleeder and loosen the bleed valve.

If not using an automatic refill system, add brake fluid when the fluid level in the reservoir is low.

- Check the fluid level often while bleeding the brakes to prevent air from being pumped into the system.
- When using a brake bleeding tool, follow the manufacturer's operating instructions.

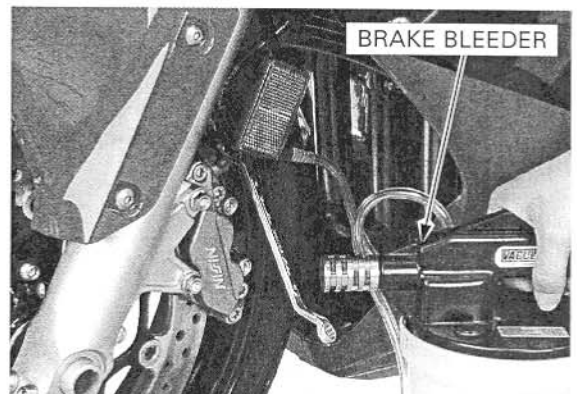

HYDRAULIC BRAKE

Perform the bleeding procedure until the system is completely flushed/bled.

- If air is entering the bleeder from around the bleed valve threads, seal the threads with teflon tape.

For the front brake, close the bleed valve and perform air bleeding for the other side bleed valve.

Operate the brake lever or pedal. If it still feels spongy, bleed the system again.

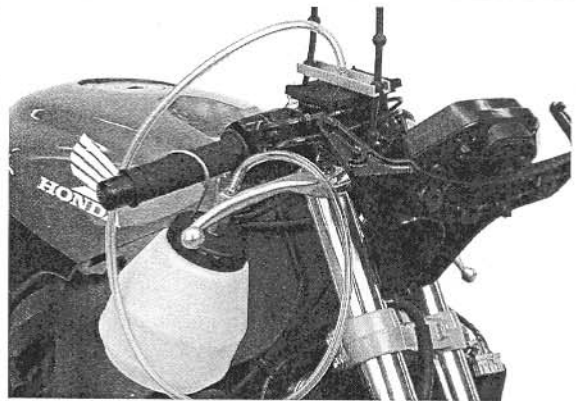

If the brake bleeder is not available, perform the following procedures:

Connect a clear bleed hose to the bleed valve. Pressurize the system with the brake lever or pedal until there are no air bubbles in the fluid flowing out of the reservoir small hole and lever or pedal resistance is felt.

Do not release the brake lever or pedal until the bleed valve has been closed.

1. Squeeze the brake lever or push the brake pedal, open the bleed valve 1/2 turn and then close the valve.
2. Release the brake lever or pedal slowly and wait several seconds after it reaches the end of its travel.
3. Repeat steps 1 and 2 until bubbles cease to appear in the fluid coming out of the bleed valve.
4. Tighten the bleed valve.

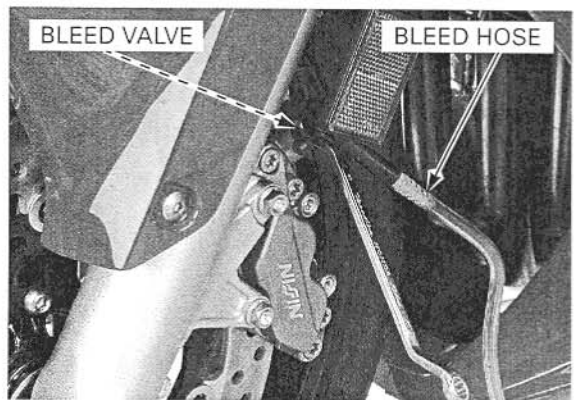

TORQUE: 5.9 N·m (0.6 kgf·m, 4.3 lbf·ft)

For the front brake, perform air bleeding for the other side bleed valve.

Fill each reservoir to the upper level with DOT 4 brake fluid from a sealed container.

For the front brake, reinstall the float.

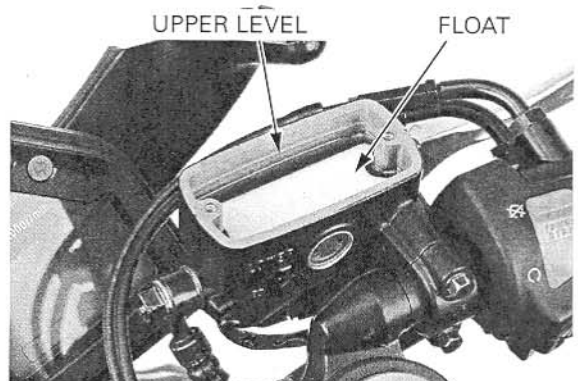

Reinstall the diaphragms and diaphragm plates.

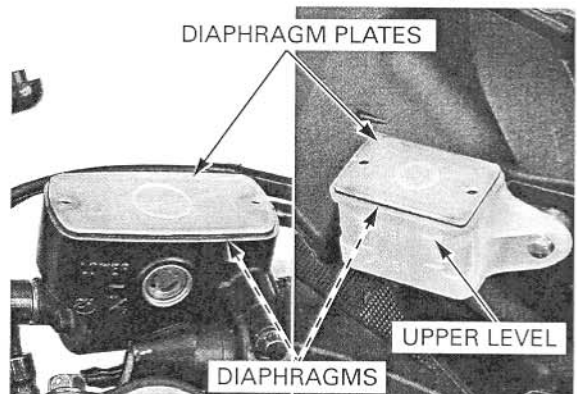

HYDRAULIC BRAKE

On the front brake, install the reservoir cap and tighten the screws to the specified torque.

TORQUE: 1.5 N·m (0.15 kgf·m, 1.1 lbf·ft)

Install the upper cowl (page 3-12).

FRONT:

SCREWS

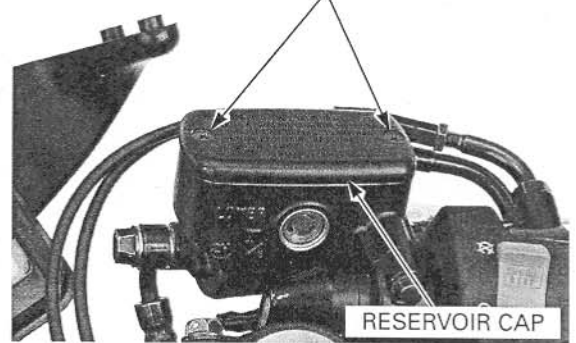

On the rear brake, install the reservoir cap and tighten the screws to the specified torque.

TORQUE: 1.5 N·m (0.15 kgf·m, 1.1 lbf·ft)

Install the rear cowl (page 3-5).

REAR:

RESERVOIR CAP

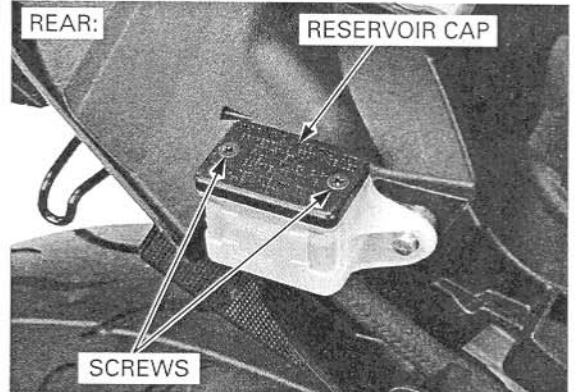

BRAKE PAD/DISC

Always replace the brake pads in pairs to assure even disc pressure.

FRONT BRAKE PAD REPLACEMENT

Loosen the pad pins.

Remove the caliper mounting bolts and brake caliper.

Discard the brake caliper mounting bolts.

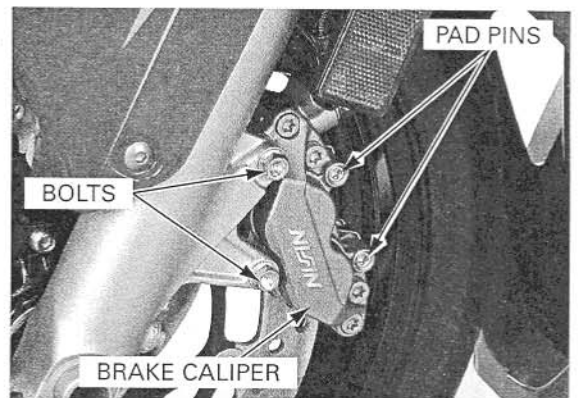

Check the brake fluid level in the brake master cylinder reservoir as this operation causes the level to rise.

Push the caliper pistons all the way in to allow installation of new brake pads.

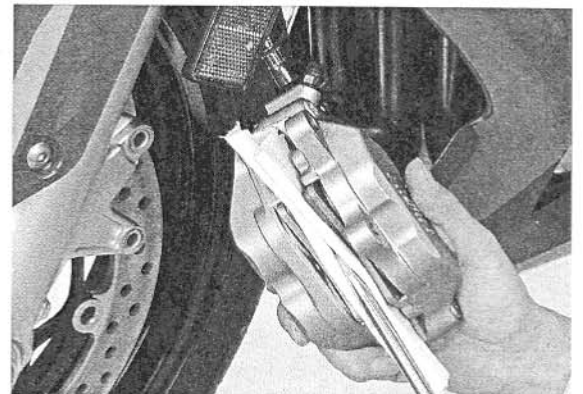

HYDRAULIC BRAKE

Remove the pad pins, pad spring and brake pads.

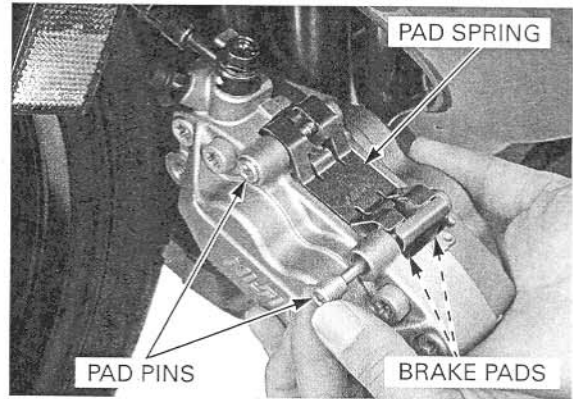

Clean the inside of the caliper especially around the caliper pistons.

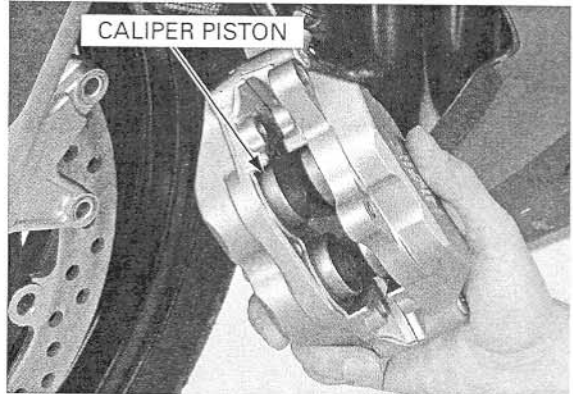

Install the new brake pads.
Install the pad spring with its arrow mark facing up as shown.
Install the pad pins while pushing in the pad spring.

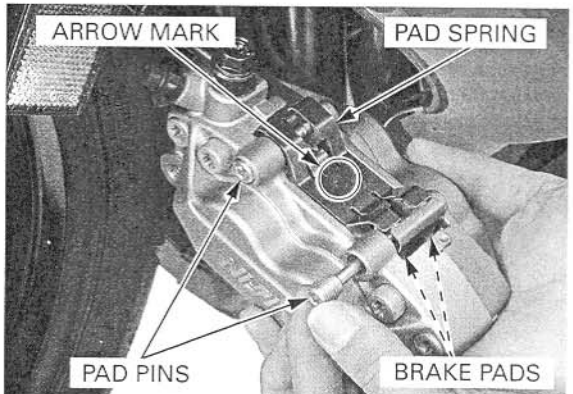

Be careful not to damage the pads. Install the brake caliper to the fork leg so that the disc is positioned between the pads.

Tighten the new brake caliper mounting bolts to the specified torque.

TORQUE: 30 N·m (3.1 kgf·m, 22 lbf·ft)

Tighten the pad pins to the specified torque.

TORQUE: 18 N·m (1.8 kgf·m, 13 lbf·ft)

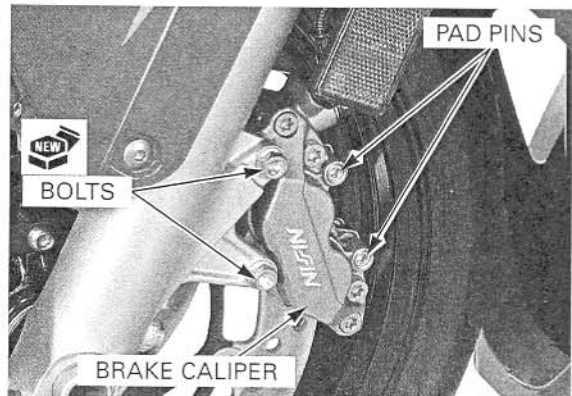

REAR BRAKE PAD REPLACEMENT

Always replace the brake pads in pairs to assure even disc pressure.

Check the brake fluid level in the brake master cylinder reservoir as this operation causes the level to rise.

Push the caliper piston all the way in by pushing the caliper body inward to allow installation of new brake pads.

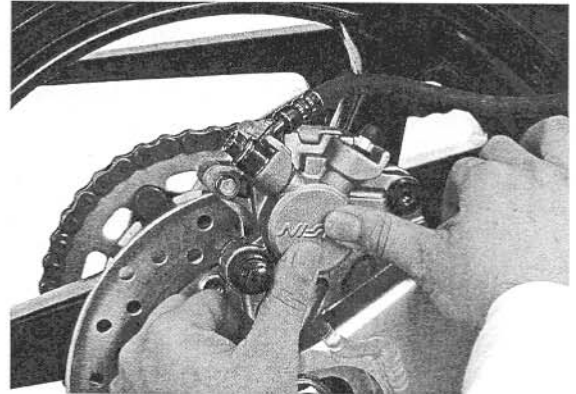

Loosen the pad pin.
Remove the caliper mounting bolt.

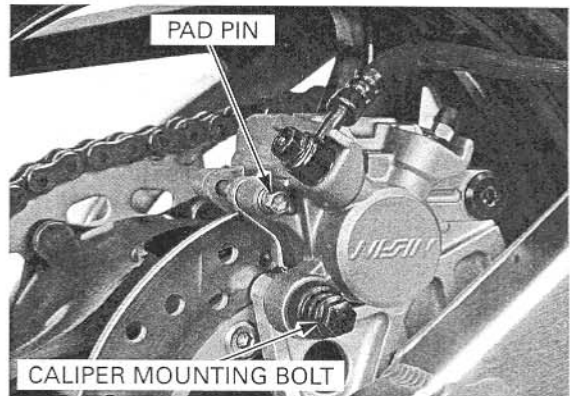

Pivot the caliper up.
Remove the pad pin and brake pads.
Clean the inside of the caliper especially around the caliper pistons.

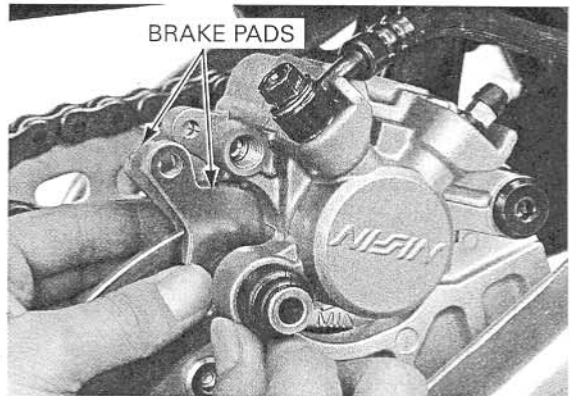

Make sure the brake pad spring is in place.
Install new brake pads.
Lower the caliper while pushing the pads against the pad spring so that the pad ends are positioned onto the retainer on the caliper bracket.
Install a new O-ring into the pad pin groove.
Install the pad pin.

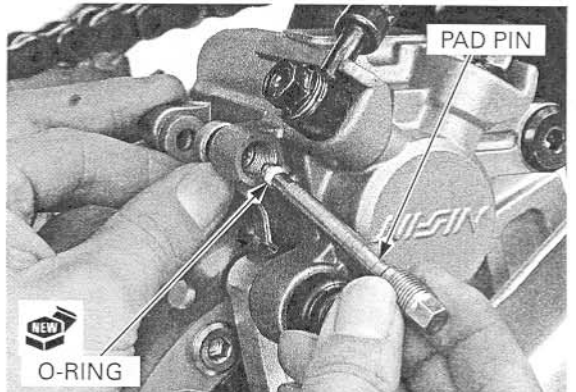

HYDRAULIC BRAKE

Tighten the caliper mounting bolt to the specified torque.

TORQUE: 23 N·m (2.3 kgf·m, 17 lbf·ft)

Tighten the pad pin to the specified torque.

TORQUE: 18 N·m (1.8 kgf·m, 13 lbf·ft)

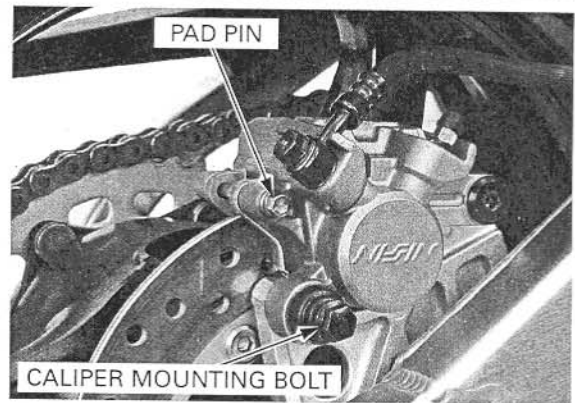

BRAKE DISC INSPECTION

Visually inspect the brake discs for damage or cracks.

Measure the brake disc thickness with a micrometer.

SERVICE LIMITS:

FRONT: 3.5 mm (0.14 in)

REAR: 4.0 mm (0.16 in)

Replace the brake disc if the smallest measurement is less than the service limit.

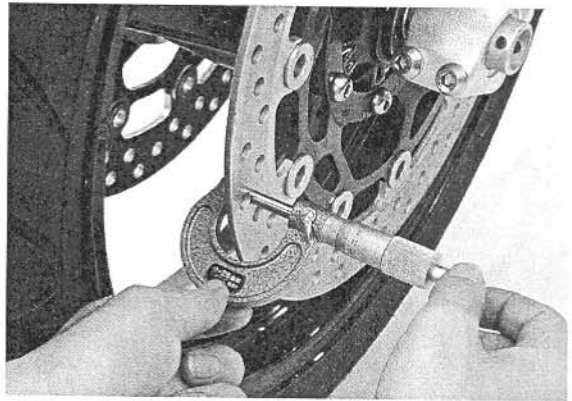

Measure the brake disc warpage with a dial indicator.

SERVICE LIMITS:

FRONT: 0.30 mm (0.0012 in)

REAR: 0.30 mm (0.0012 in)

Check the wheel bearings for excessive play (page 14-13), if the warpage exceeds the service limit. Replace the brake disc if the wheel bearings are normal.

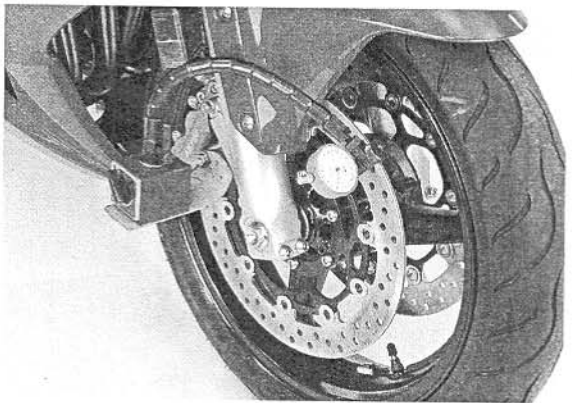

FRONT MASTER CYLINDER

NOTICE

Spilled fluid can damage painted, plastic, or rubber parts. Place a rag over these parts whenever the system is serviced.

REMOVAL

Drain the front hydraulic system (page 16-6).

Disconnect the brake light switch wire connectors.

Remove the brake hose oil bolt, sealing washers and brake hose eyelet joint.

Avoid spilling fluid on painted, plastic, or rubber parts. Place a rag over these parts whenever the system is serviced.

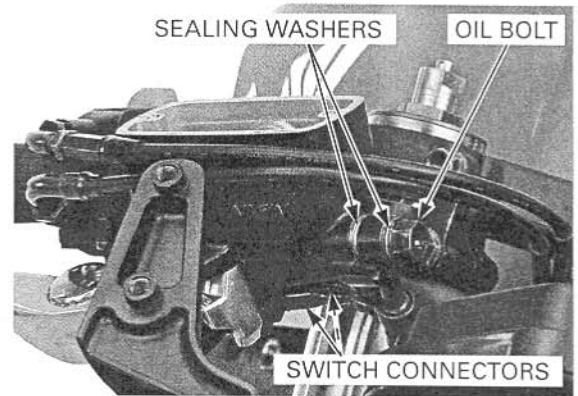

Remove the bolts from the master cylinder holder and remove the master cylinder assembly.

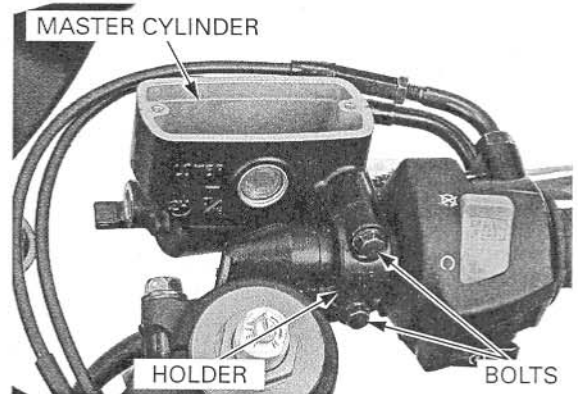

DISASSEMBLY

Remove the pivot bolt/nut and brake lever assembly.

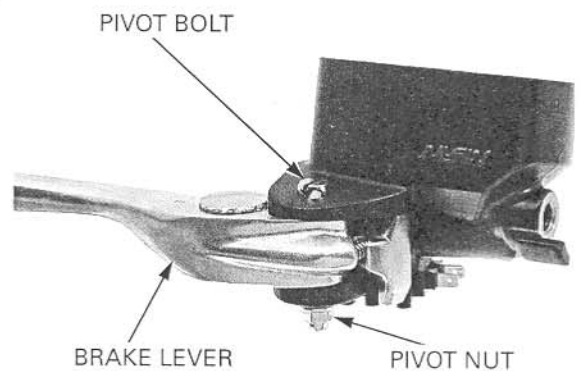

HYDRAULIC BRAKE

Remove the screw and brake light switch.

SCREW BRAKE LIGHT SWITCH

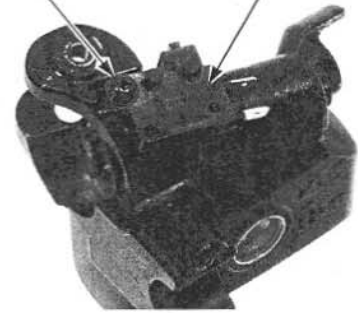

Be careful not to damage the boot. Remove the boot.

BOOT

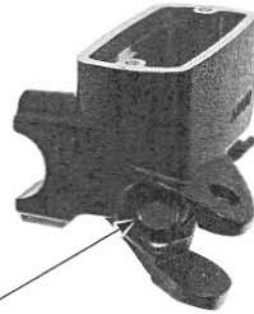

Remove the snap ring from the master cylinder body using the special tool as shown.

TOOL:

Snap ring pliers

07914-SA50001

SNAP RING SNAP RING PLIERS

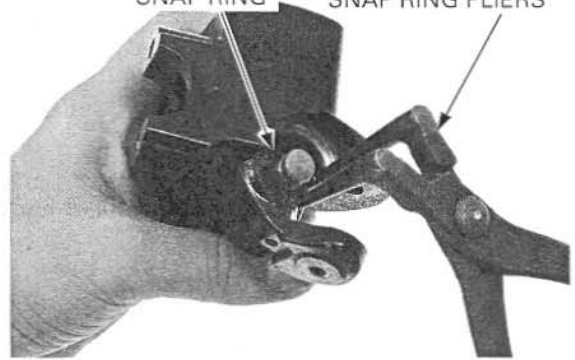

Remove the master piston and spring.

Clean the inside of the cylinder and reservoir with clean brake fluid.

SPRING

MASTER PISTON

MASTER CYLINDER

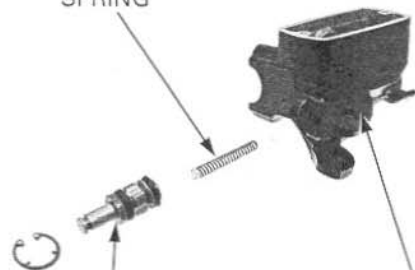

INSPECTION

Check the piston boot, primary cup and secondary cup for fatigue or damage.
 Check the master cylinder and piston for abnormal scratches.
 Measure the master cylinder I.D.

SERVICE LIMIT: 17.515 mm (0.6896 in)

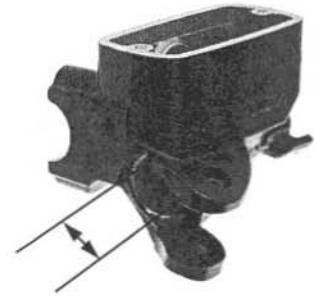

Measure the master cylinder piston O.D.

SERVICE LIMIT: 17.309 mm (0.6815 in)



ASSEMBLY

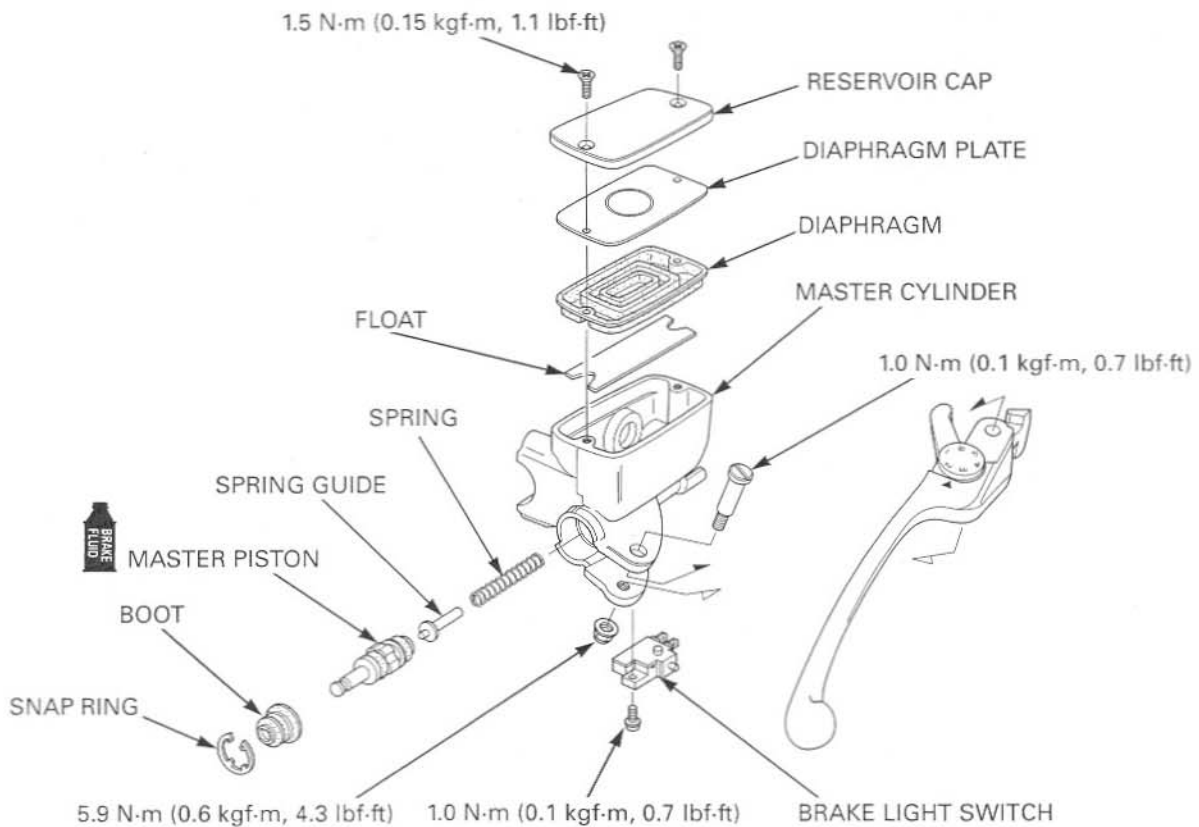

HYDRAULIC BRAKE

Keep the piston, cups, spring, snap ring and boot as a set; do not substitute individual parts.

When installing the cups, do not allow the lips to turn inside out.

Be certain the snap ring is firmly seated in the groove.

Coat all parts with clean brake fluid before assembly.

Dip the piston in brake fluid.
Install the spring into the piston.
Install the piston assembly into the master cylinder.

Install the snap ring with the special tool.

TOOL:
Snap ring pliers

07914-SA50001

Install the boot.

Install the brake light switch and tighten the screw to the specified torque.

TORQUE: 1.0 N·m (0.1 kgf·m, 0.7 lbf·ft)

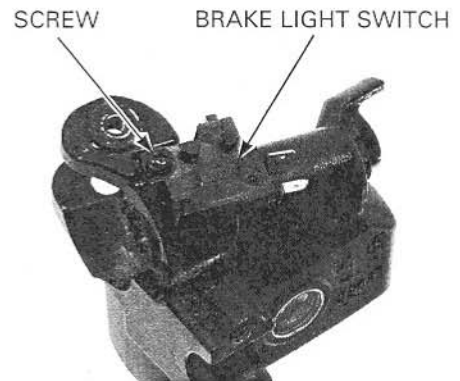
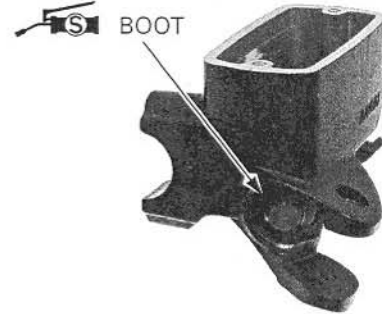
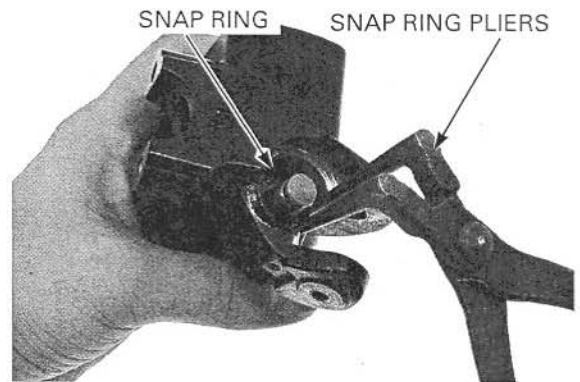
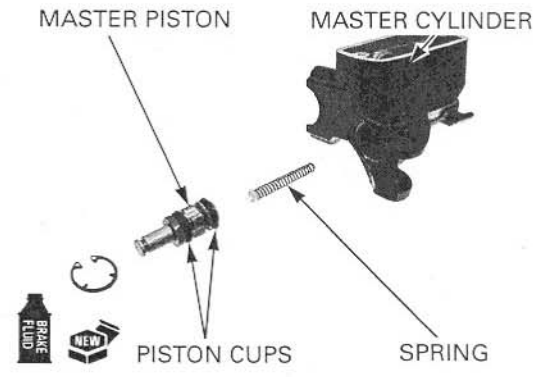

HYDRAULIC BRAKE

Apply silicone grease to the contact surfaces of the brake lever and piston tip.

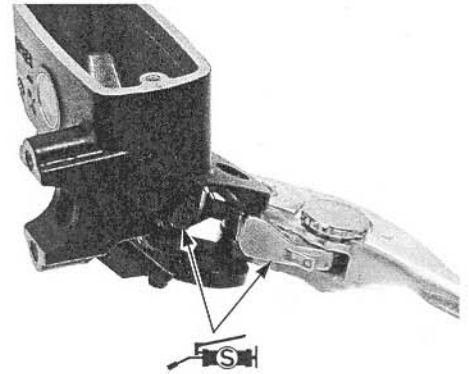

Apply silicone grease to the brake lever pivot bolt sliding surface.

Install the brake lever assembly, tighten the pivot bolt to the specified torque.

TORQUE: 1.0 N·m (0.1 kgf·m, 0.7 lbf·ft)

Hold the pivot bolt and tighten the pivot nut to the specified torque.

TORQUE: 5.9 N·m (0.6 kgf·m, 4.3 lbf·ft)

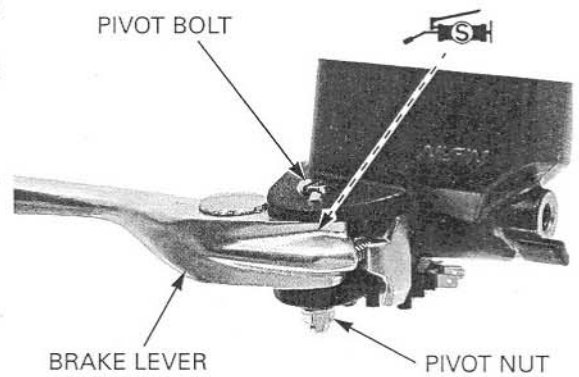

Place the master cylinder assembly on the handlebar.

Align the end of the master cylinder with the punch mark on the handlebar.

Install the master cylinder holder with its "UP" mark facing up.

Tighten the upper bolt first, then the lower bolt to the specified torque.

TORQUE: 12 N·m (1.2 kgf·m, 9 lbf·ft)

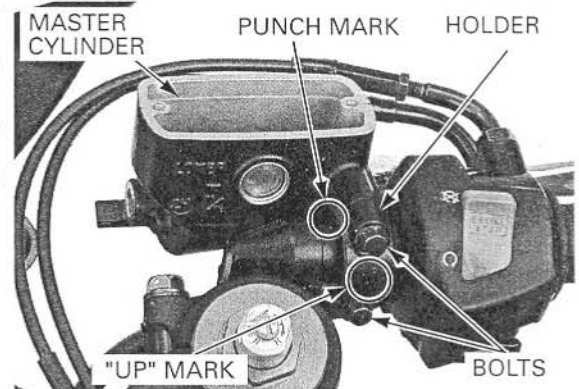

Install the brake hose eyelet with the oil bolt and new sealing washers.

Push the eyelet joint against the stopper, then tighten the oil bolt to the specified torque.

TORQUE: 34 N·m (3.5 kgf·m, 25 lbf·ft)

Connect the brake light switch wire connectors.

Fill brake fluid and bleed air the front brake hydraulic system (page 16-7).

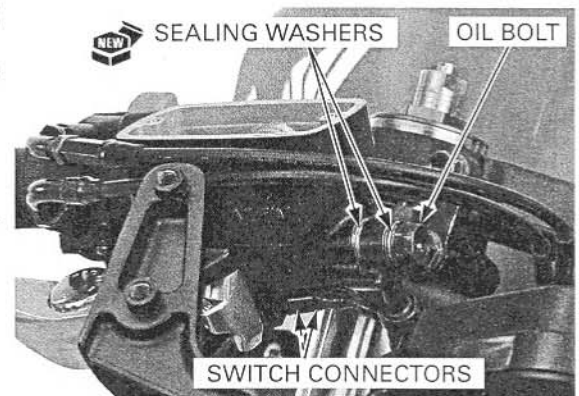

HYDRAULIC BRAKE

REAR MASTER CYLINDER

NOTICE

Spilled fluid can damage painted, plastic, or rubber parts. Place a rag over these parts whenever the system is serviced.

REMOVAL

Drain the rear hydraulic system (page 16-6).

Remove the rear master cylinder reservoir mounting bolt.

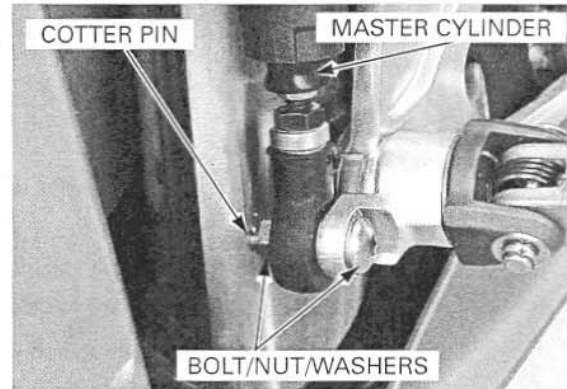
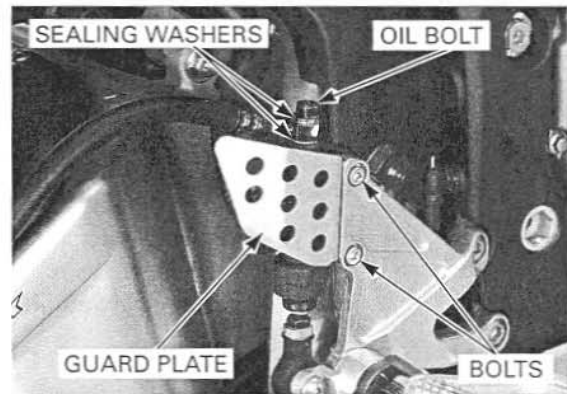
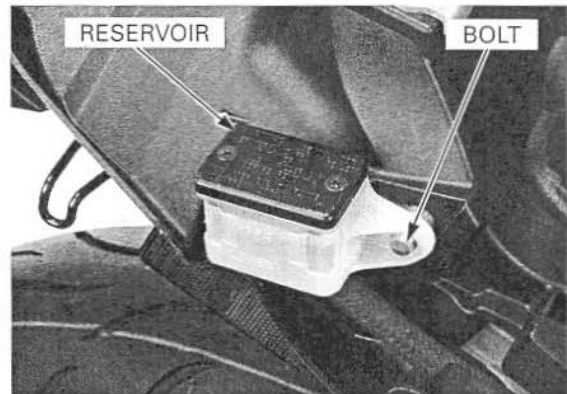

Avoid spilling fluid on painted, plastic, or rubber parts. Place a rag over these parts whenever the system is serviced.

Remove the brake hose oil bolt, sealing washers and brake hose eyelet joint.

Remove the rear master cylinder mounting bolts and master cylinder guard plate.

Remove and discard the brake pedal joint cotter pin. Remove the bolt, nut, washers and rear master cylinder from the right driver footpeg bracket.

DISASSEMBLY

Remove the screw and reservoir hose joint from the master cylinder.

Remove the O-ring from the joint.

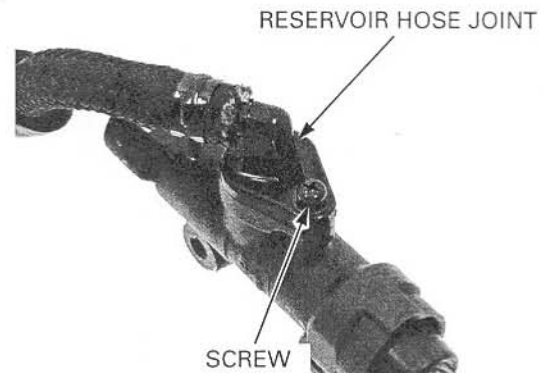

Be careful not to damage the boot.

Remove the boot from the master cylinder body.

Remove the snap ring from the master cylinder body using the special tool as shown.

TOOL:

Snap ring pliers

07914-SA50001

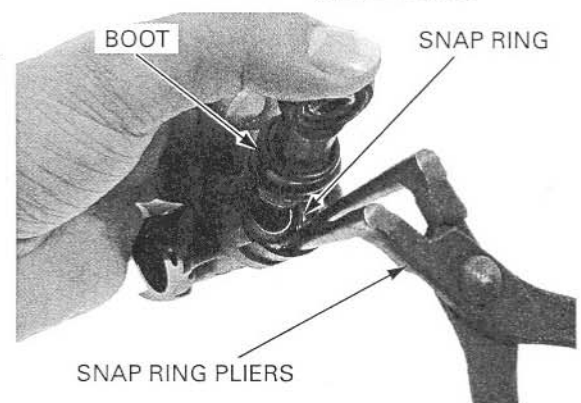

Remove the push rod, master piston and spring.

Clean the inside of the cylinder with clean brake fluid.

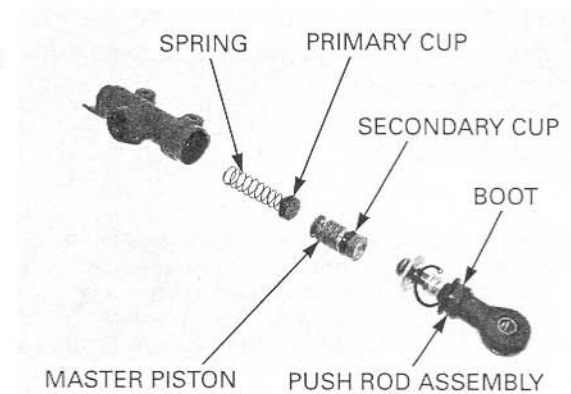

INSPECTION

Check the piston boot, primary cup and secondary cup for fatigue or damage.

Check the master cylinder and piston for abnormal scratches.

Measure the master cylinder I.D.

SERVICE LIMIT: 15.925 mm (0.6270 in)

Measure the master cylinder piston O.D.

SERVICE LIMIT: 15.815 mm (0.6226 in)

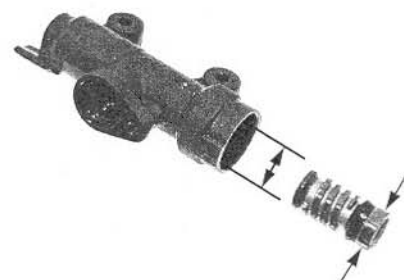

HYDRAULIC BRAKE

ASSEMBLY

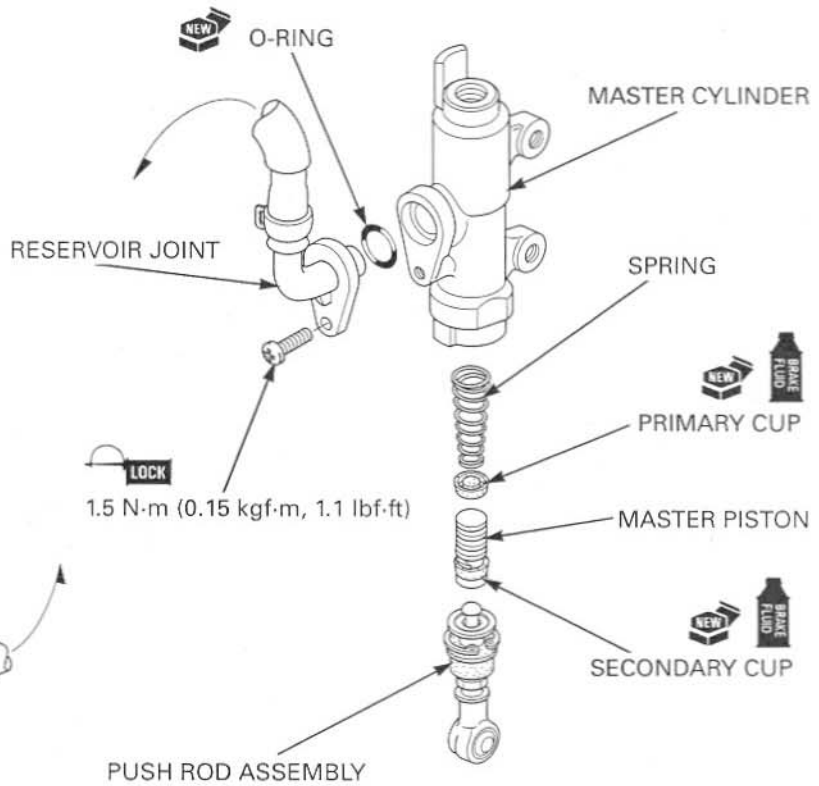
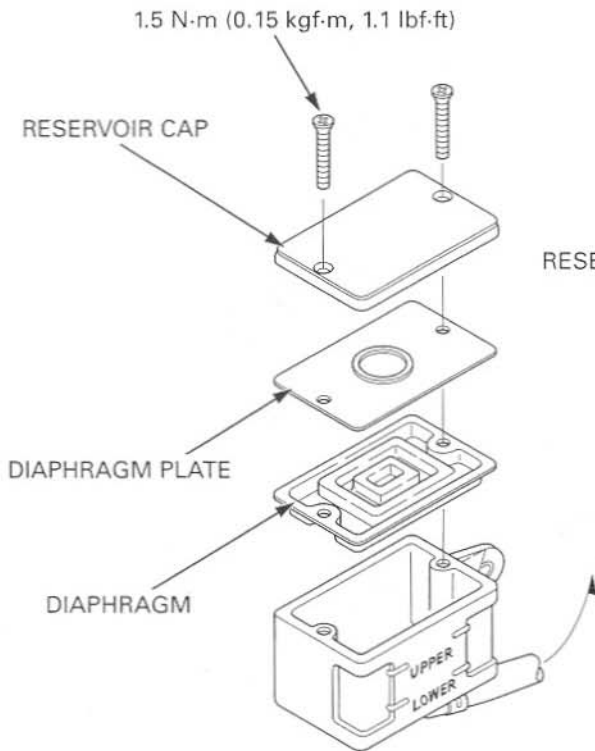

Keep the piston, cups, spring, snap ring and boot as a set; do not substitute individual parts.

When installing the cups, do not allow the lips to turn inside out.

If the push rod is disassembled, refer to (page 4-27) for push rod length adjustment.

Be certain the snap ring is firmly seated in the groove.

Coat all parts with clean brake fluid before assembly.

Dip the piston in brake fluid. Install the spring to the primary cup. Install the spring/primary cup and master piston assembly into the master cylinder. Apply silicone grease to the piston contact area of the push rod.

Install the push rod into the master cylinder.

Install the snap ring with the special tool.

TOOL:
Snap ring pliers
Install the boot.

07914-SA50001

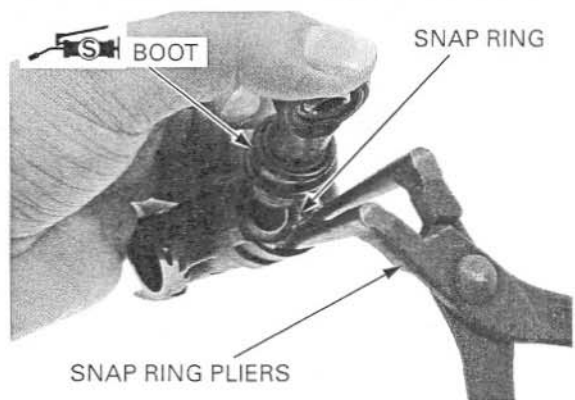
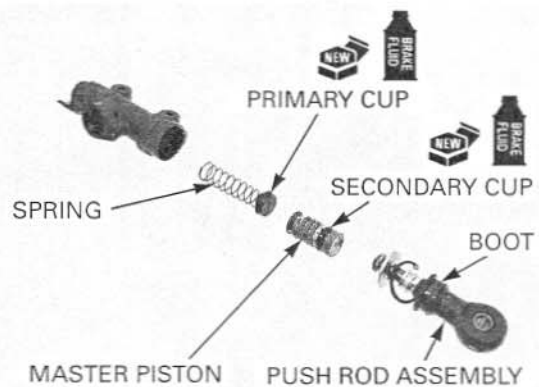

Apply brake fluid to a new O-ring and install it onto the reservoir joint.
Install the reservoir joint into the master cylinder.

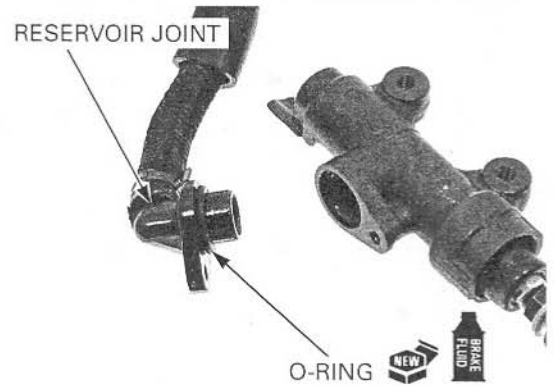

Apply a locking agent to the reservoir joint screw threads.
Tighten the screw to the specified torque.

TORQUE: 1.5 N·m (0.15 kgf·m, 1.1 lbf·ft)

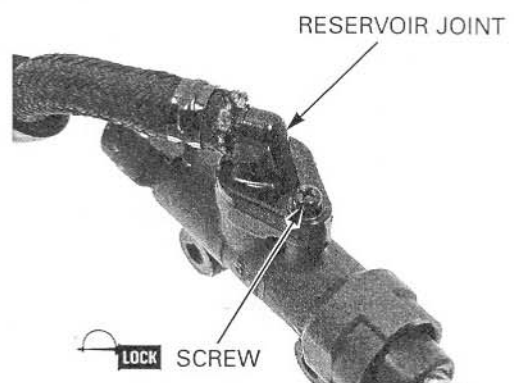

INSTALLATION

Connect the brake pedal to the push rod lower joint.
Install the bolt, washers, nut and tighten the nut securely.

Install a new cotter pin.

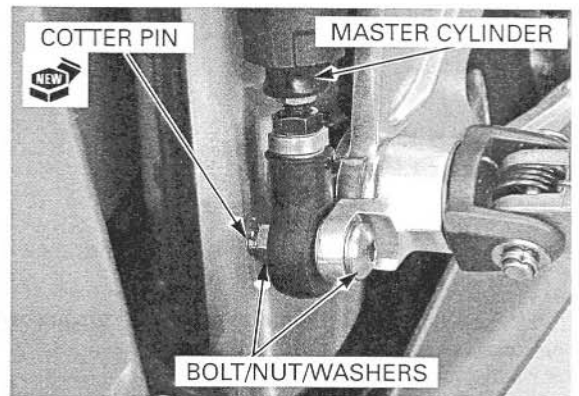

Install the master cylinder and guard plate, tighten the bolts to the specified torque.

TORQUE: 8.8 N·m (0.9 kgf·m, 6.5 lbf·ft)

Install the brake hose with the oil bolt and new sealing washers.
Push the eyelet joint against the stopper, then tighten the oil bolt to the specified torque.

TORQUE: 34 N·m (3.5 kgf·m, 25 lbf·ft)

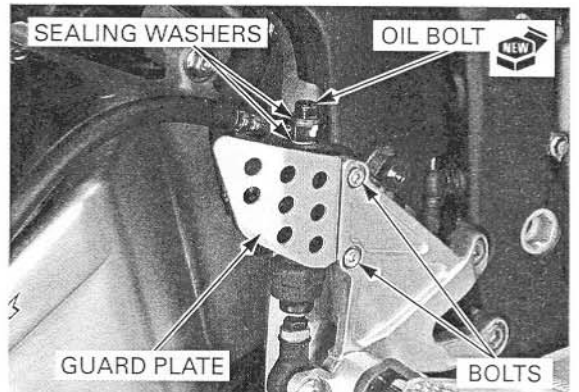

HYDRAULIC BRAKE

Rout the brake hose properly (page 1-22).

Install and tighten the brake reservoir mounting bolt to the specified torque.

TORQUE: 12 N·m (1.2 kgf·m, 9 lbf·ft)

Fill brake fluid and bleed air the rear brake hydraulic system (page 16-7).

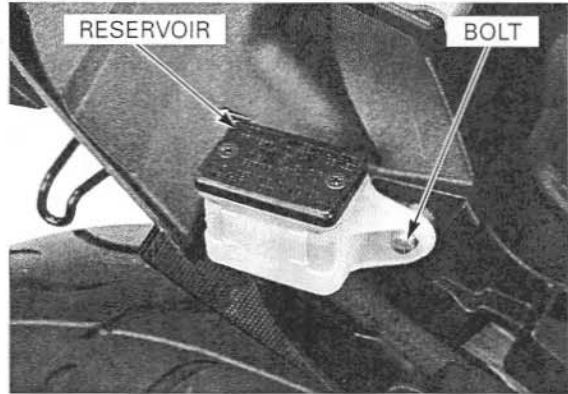

FRONT BRAKE CALIPERS

NOTICE

Spilled fluid can damage painted, plastic, or rubber parts. Place a rag over these parts whenever the system is serviced.

REMOVAL

Drain the front brake hydraulic system (page 16-6).

Avoid spilling fluid on painted, plastic, or rubber parts. Place a rag over these parts whenever the system is serviced.

Remove the brake hose oil bolt, sealing washers and brake hose eyelet joint.

Remove the caliper mounting bolts and brake caliper.

Remove the brake pads (page 16-9).

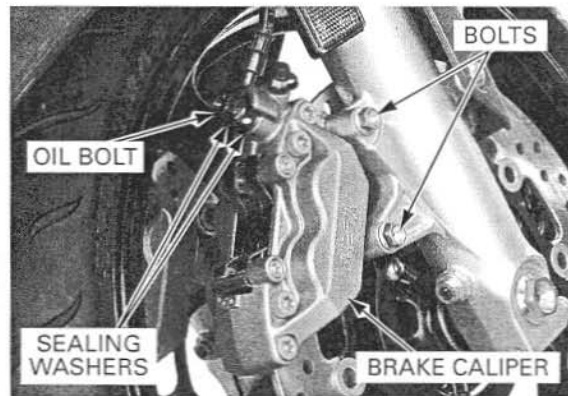

DISASSEMBLY

Install a corrugated cardboard or soft wood sheet between the pistons.

Do not use high pressure air or bring the nozzle too close to the inlet.

Apply small squirts of air pressure to the fluid inlet to remove the pistons.

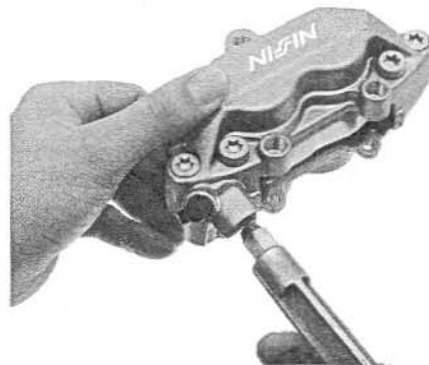

HYDRAULIC BRAKE

Remove the four caliper assembly torx bolts and separate the caliper halves.

ASSEMBLY BOLTS

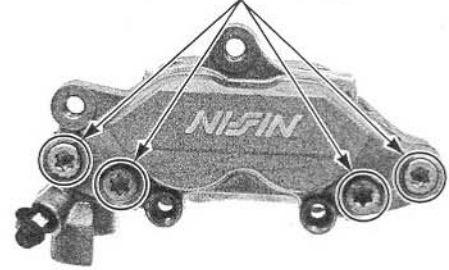

Mark the pistons to ensure correct reassembly.

Remove the following:

- Joint seal
- Caliper piston A
- Caliper piston B

PISTON B

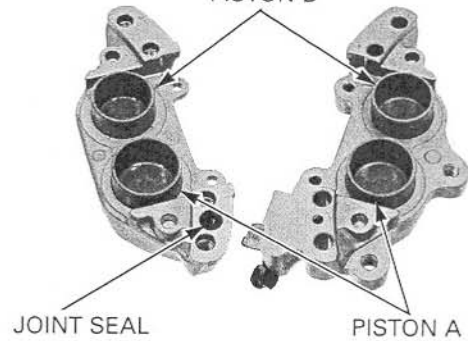

Be careful not to damage the piston sliding surface.

Push the dust seals and piston seals in and lift them out.

Clean the seal grooves with clean brake fluid.

PISTON SEAL

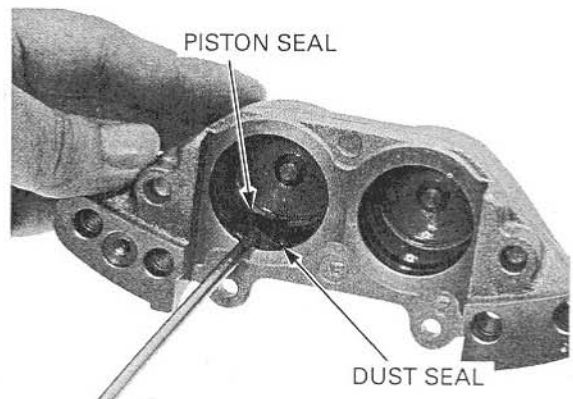

INSPECTION

Check the caliper cylinder for scoring or other damage.

Measure the caliper cylinder I.D.

SERVICE LIMITS:

Cylinder A: 32.092 mm (1.2635 in)

Cylinder B: 30.292 mm (1.1926 in)

CYLINDER A

CYLINDER B

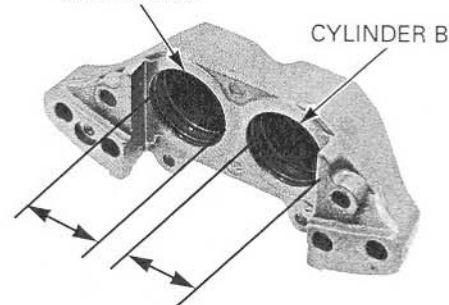

HYDRAULIC BRAKE

Check the caliper pistons for scratches, scoring or other damage.

Measure the caliper piston O.D.

SERVICE LIMITS:

Piston A: 31.940 mm (1.2574 in)

Piston B: 30.074 mm (1.1840 in)

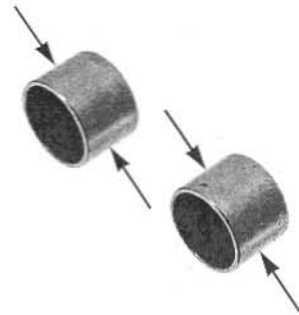

ASSEMBLY

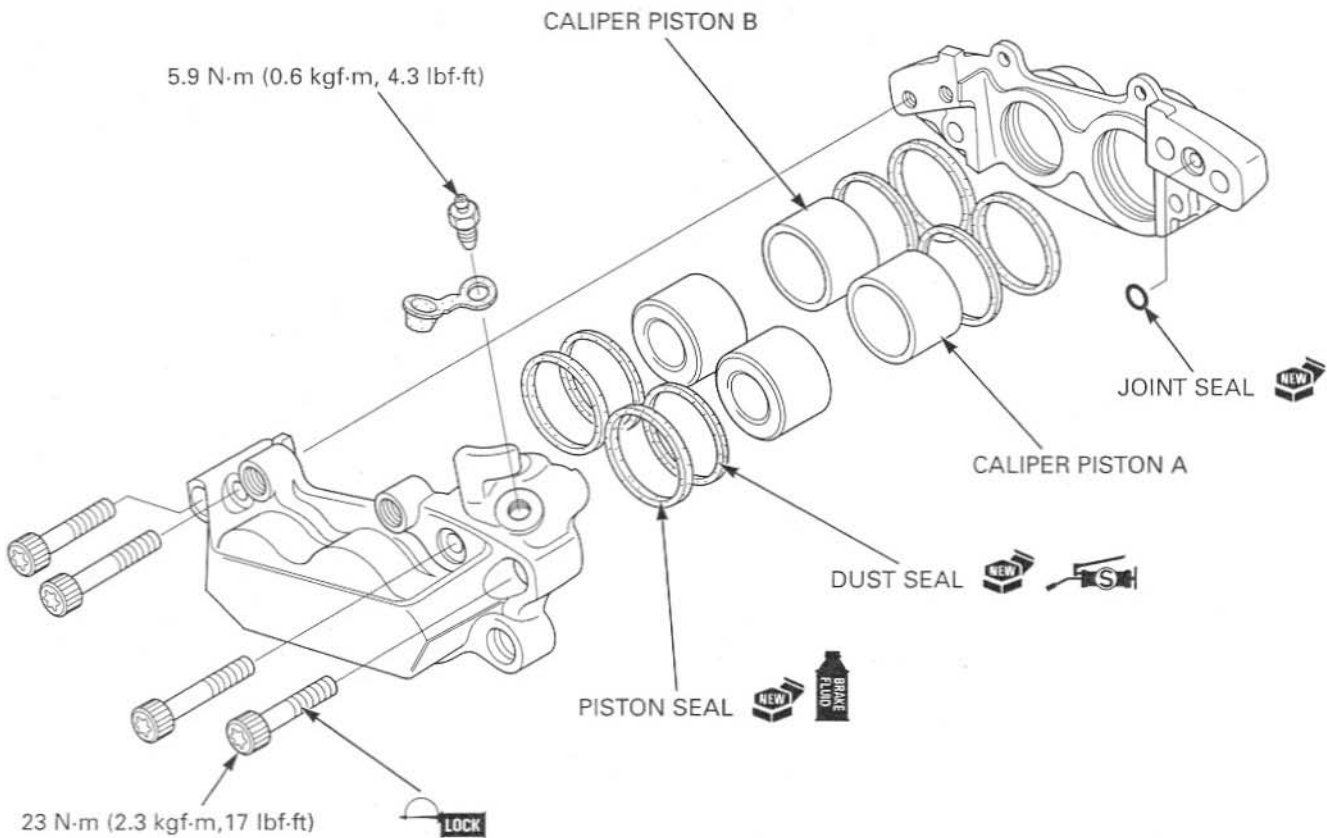

Coat new piston seals with clean brake fluid.
Coat new dust seals with silicone grease.

Install the piston and dust seals into the grooves of the caliper body.

Coat the caliper pistons with clean brake fluid and install them into the caliper cylinder with their open ends toward the pad.

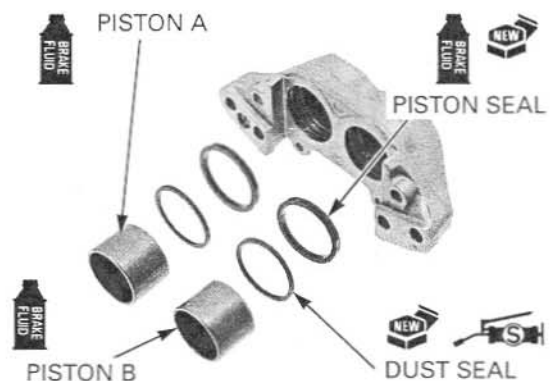

Install the new joint seal into the fluid passage on caliper.

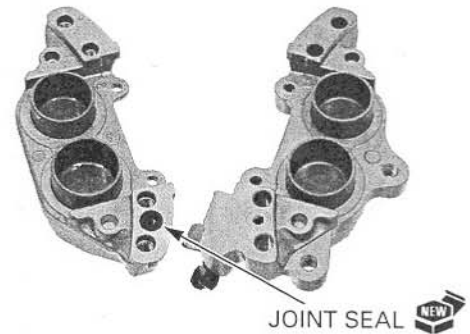

Assemble the caliper halves.
Apply a locking agent to the caliper assembly torx bolt threads.
Tighten the caliper assembly torx bolts to the specified torque.

TORQUE: 23 N·m (2.3 kgf·m, 17 lbf·ft)

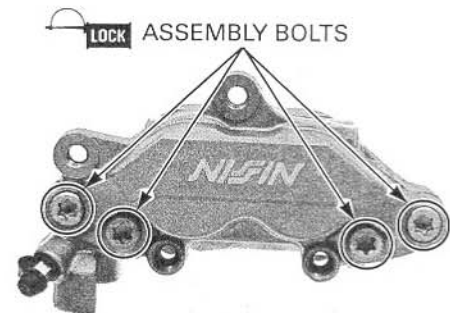

INSTALLATION

Install the brake pads and caliper onto the fork leg (page 16-9).

Tighten the new caliper mounting bolts to the specified torque.

TORQUE: 30 N·m (3.1 kgf·m, 22 lbf·ft)

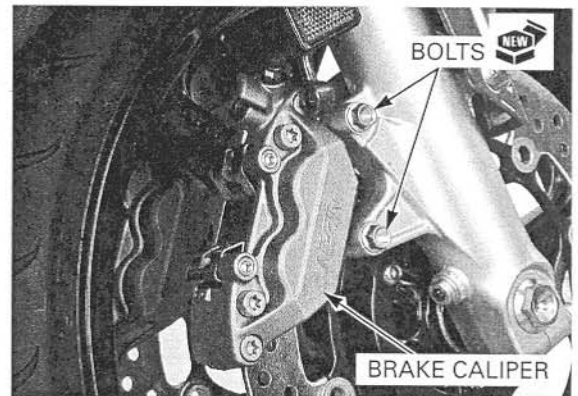

Install the brake hose eyelet joint to the caliper body with two new sealing washers and oil bolt.

Push the brake hose eyelet joint to the stopper on the caliper, then tighten the oil bolt to the specified torque.

TORQUE: 34 N·m (3.5 kgf·m, 25 lbf·ft)

Fill brake fluid and bleed air the front brake hydraulic system (page 16-7).

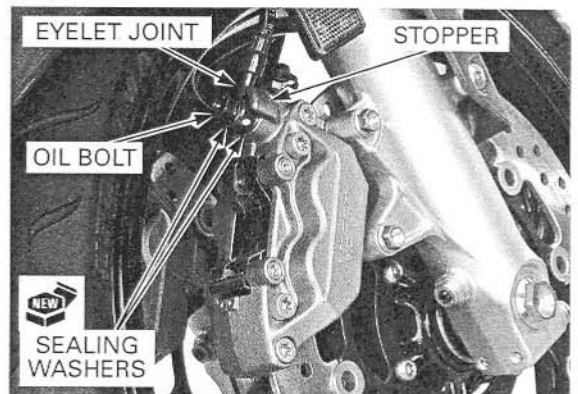

HYDRAULIC BRAKE

REAR BRAKE CALIPER

NOTICE

Spilled fluid can damage painted, plastic, or rubber parts. Place a rag over these parts whenever the system is serviced.

REMOVAL

Drain the rear brake hydraulic system (page 16-6).

Avoid spilling fluid on painted, plastic, or rubber parts. Place a rag over these parts whenever the system is serviced.

Remove the oil bolt, sealing washers and brake hose eyelet joint.

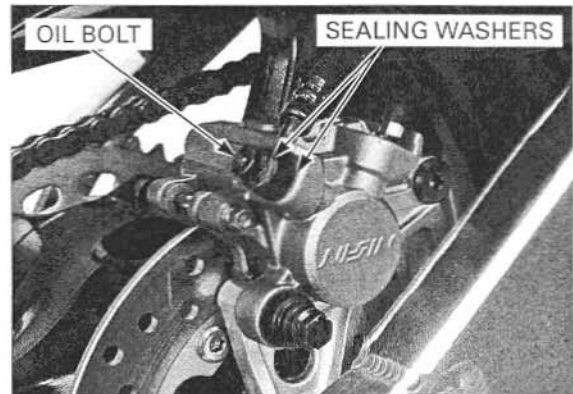

Remove the caliper mounting bolt and the brake pads (page 16-11).

Pivot the caliper up and remove it.

Remove the pad retainer.

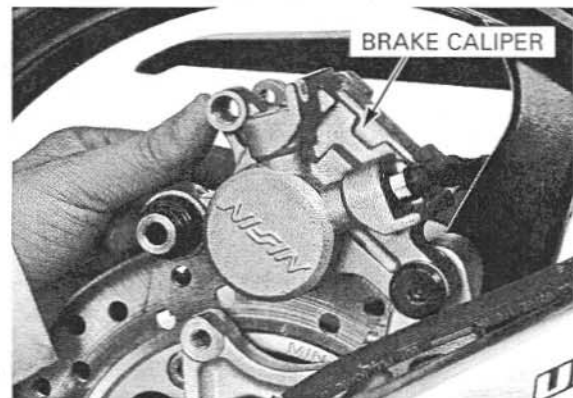

DISASSEMBLY

Remove the pad spring, collar and boot from the caliper body.

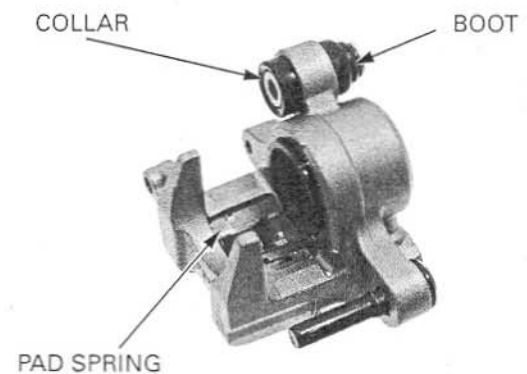

Place a shop towel over the piston.

Do not use high pressure air or bring the nozzle too close to the inlet.

Position the caliper body with the piston down and apply small squirts of air pressure to the fluid inlet to remove the piston.

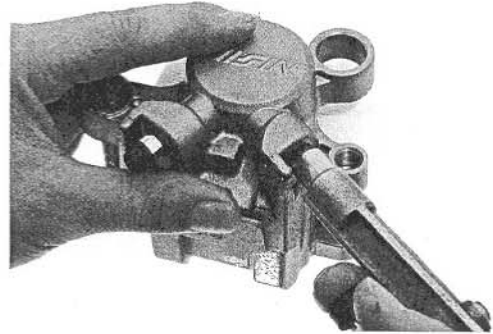

Be careful not to damage the piston sliding surface.

Push the dust seal and piston seal in and lift them out.

Clean the seal grooves with clean brake fluid.

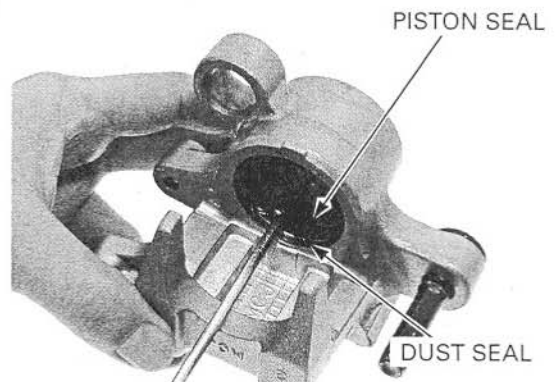

INSPECTION

Check the caliper cylinder for scoring or other damage.

Measure the caliper cylinder I.D.

SERVICE LIMIT: 38.24 mm (1.506 in)

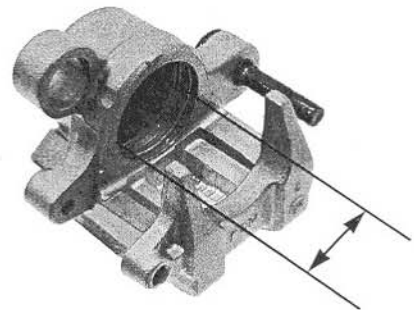

Check the caliper piston for scratches, scoring or other damage.

Measure the caliper piston O.D.

SERVICE LIMIT: 38.09 mm (1.500 in)

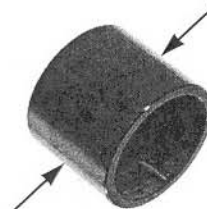

HYDRAULIC BRAKE

ASSEMBLY

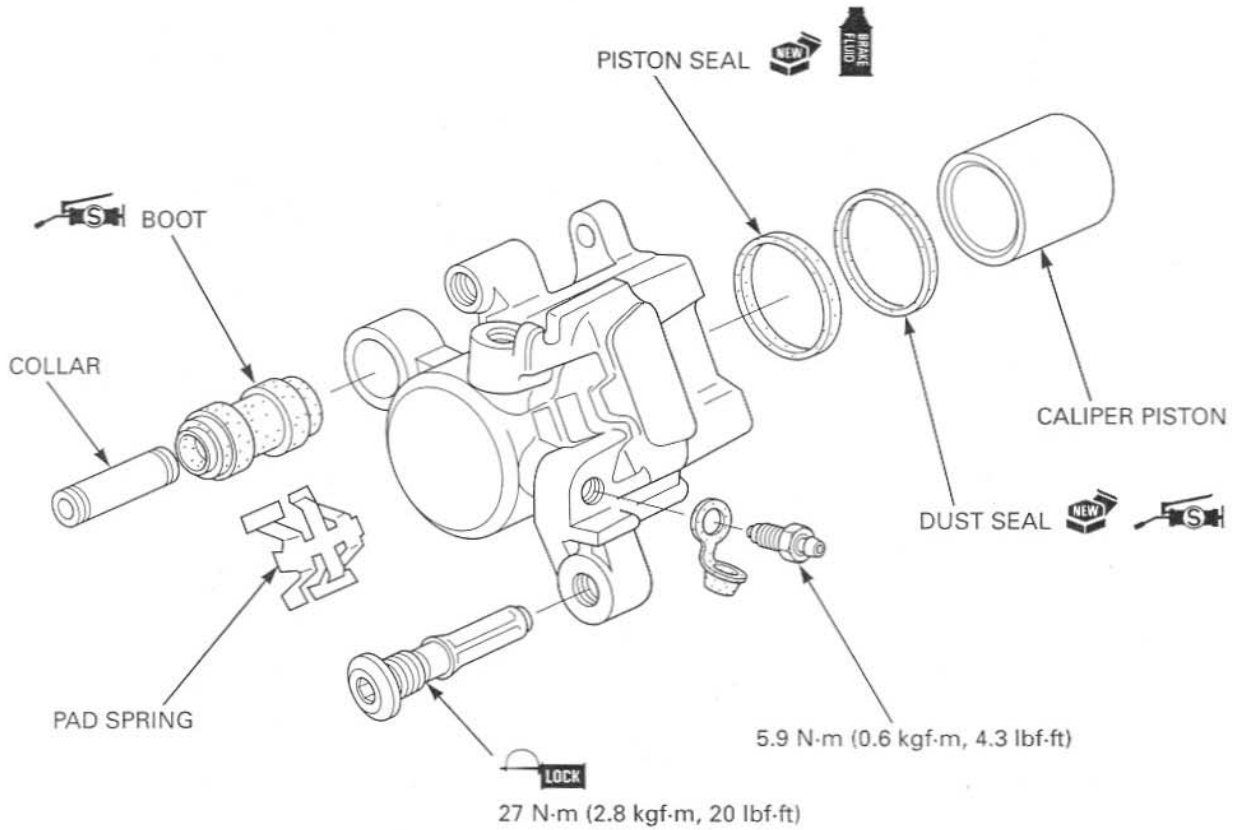

Coat a new piston seal with clean brake fluid.
Coat a new dust seal with silicone grease.

Install the piston seal and dust seal into the groove of the caliper body.

Coat the caliper piston with clean brake fluid and install it into the caliper cylinder with its open end toward the pad.

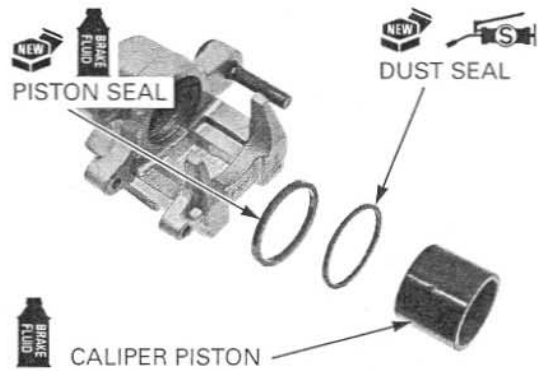

Install the pad spring into the caliper body.

Apply silicone grease to the inside of the boot and install the boot and collar into the caliper.

If the boot is hard or deteriorated, replace it with a new one.

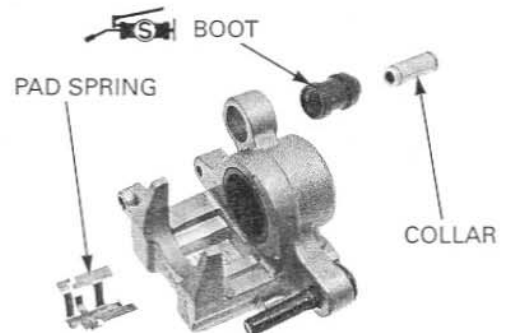

INSTALLATION

Install the pad retainer into the bracket.

Apply silicone grease to the caliper pin and install the caliper onto the bracket.

Install the brake pads (page 16-11).

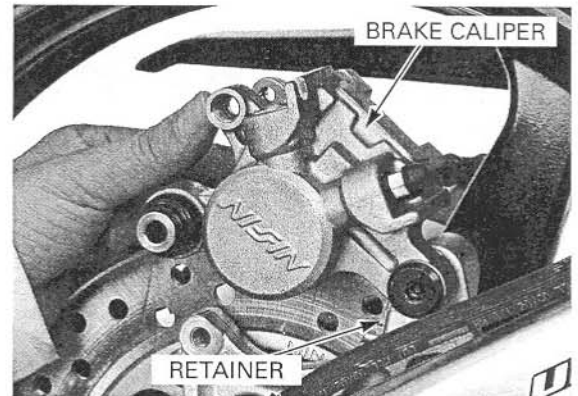

Install and tighten the caliper mounting bolt to the specified torque.

TORQUE: 23 N·m (2.3 kgf·m, 17 lbf·ft)

Install the brake hose eyelet joint to the caliper body with two new sealing washers and oil bolt. Push the brake hose eyelet joint to the stopper on the caliper, then tighten the oil bolt to the specified torque.

TORQUE: 34 N·m (3.5 kgf·m, 25 lbf·ft)

Fill brake fluid and bleed air the rear brake hydraulic system (page 16-7).

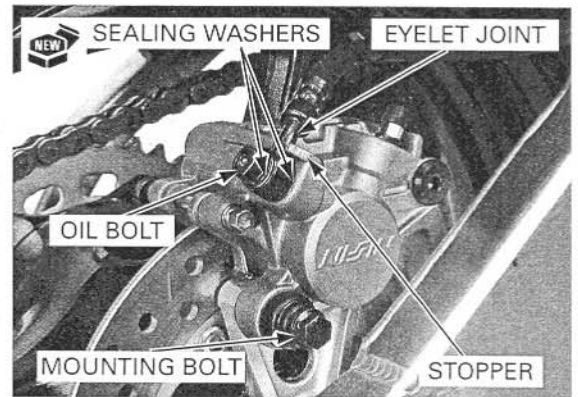

BRAKE PEDAL

REMOVAL

Remove the muffler guard bolt, driver footpeg bracket socket bolts and bracket assembly from the frame.

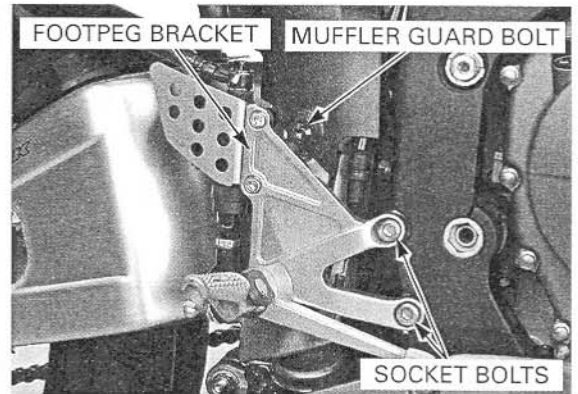

Remove and discard the brake pedal joint cotter pin. Remove the bolt, nut, washers and disconnect the push rod lower joint from the brake pedal.

Unhook the switch spring and remove the brake light switch from the footpeg bracket. Unhook the brake pedal return spring.

Remove the bolt, thrust washer, and wave washer. Remove the footpeg assembly and brake pedal from the footpeg bracket.

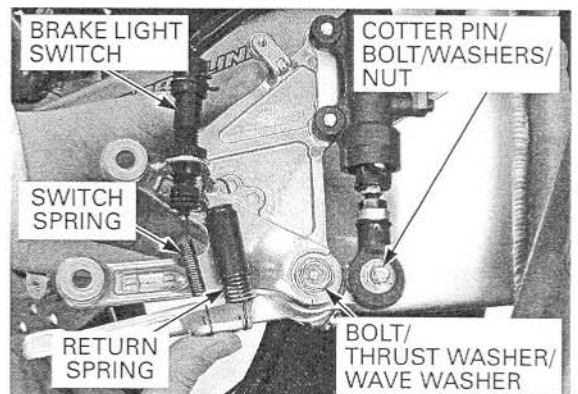

HYDRAULIC BRAKE

INSTALLATION

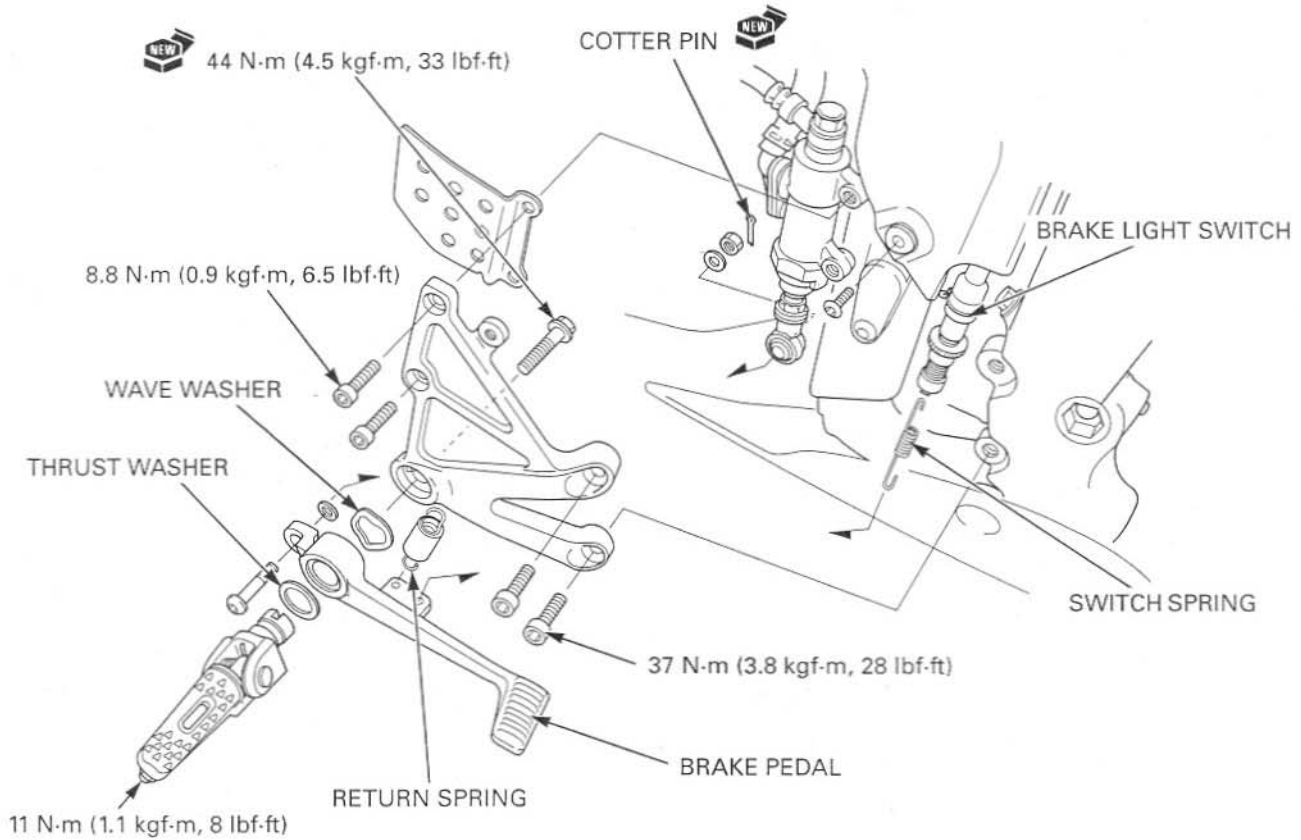

Apply grease to the sliding surface of the brake pedal and footpeg.
Install the wave washer, brake pedal, thrust washer, footpeg bracket and footpeg bolt.

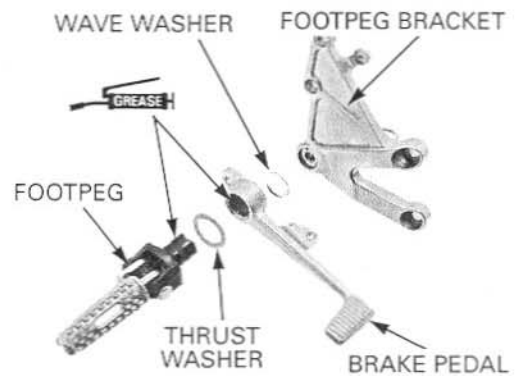

Install a new footpeg bolt and tighten it to the specified torque.

TORQUE: 44 N·m (4.5 kgf·m, 33 lbf·ft)

Hook the brake pedal return spring.

Install the brake light switch and hook the switch spring.

Connect the brake pedal to the push rod lower joint. Install the bolt, washers, nut and tighten the nut securely.

Install a new cotter pin.

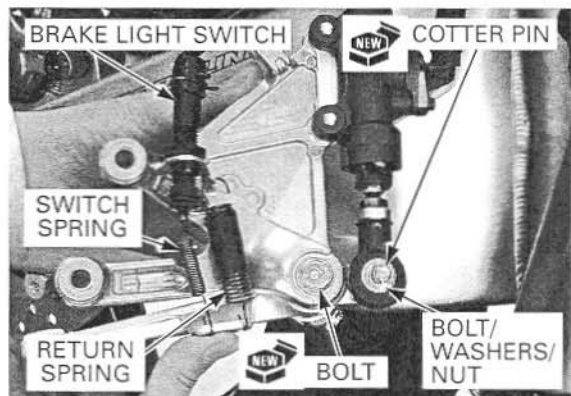

HYDRAULIC BRAKE

Install the footpeg bracket assembly onto the frame. Install and tighten the footpeg bracket socket bolts to the specified torque.

TORQUE: 37 N·m (3.8 kgf·m, 28 lbf·ft)

Tighten the muffler guard bolt.
Adjust the rear brake light switch operation (page 4-27).

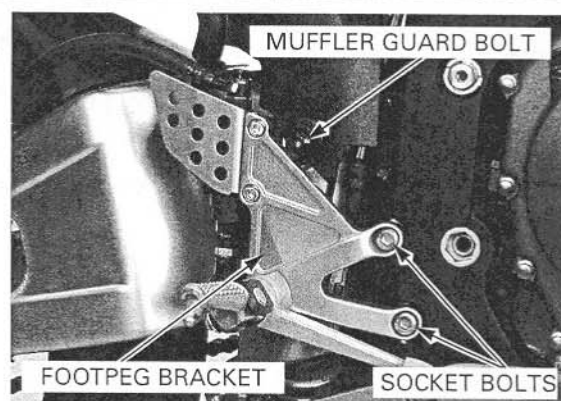

17. BATTERY/CHARGING SYSTEM

SYSTEM DIAGRAM.....	17-2	BATTERY TRAY	17-7
SERVICE INFORMATION	17-3	CHARGING SYSTEM INSPECTION.....	17-9
TROUBLESHOOTING.....	17-4	ALTERNATOR CHARGING COIL	17-9
BATTERY.....	17-5	REGULATOR/RECTIFIER	17-10

BATTERY/CHARGING SYSTEM
SYSTEM DIAGRAM

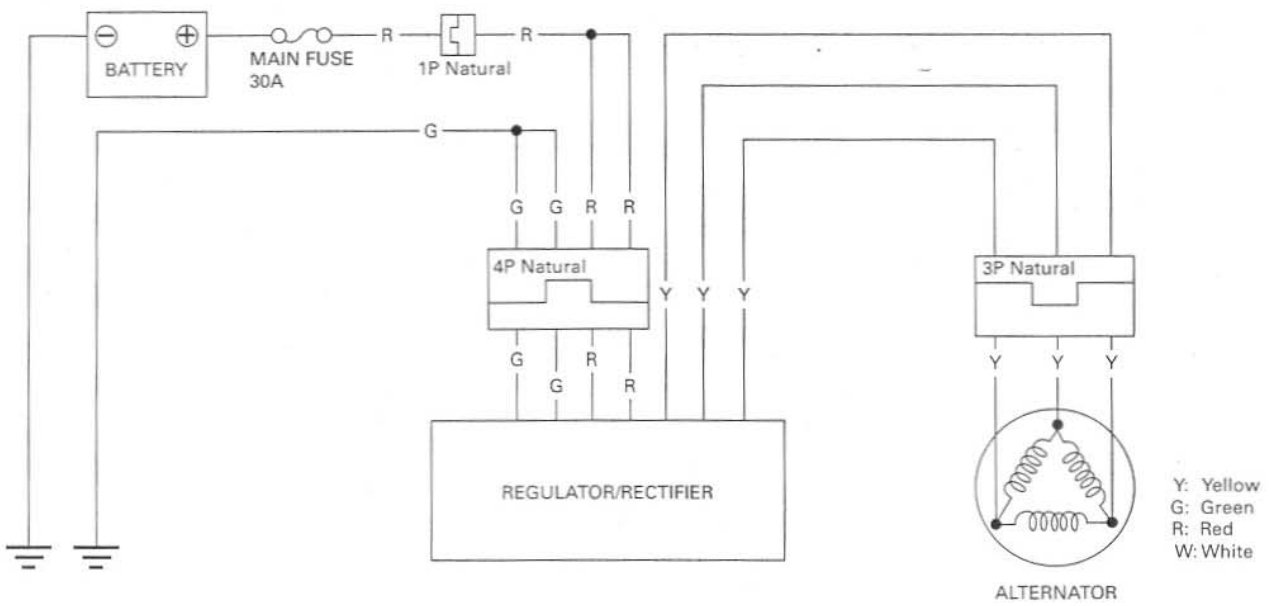
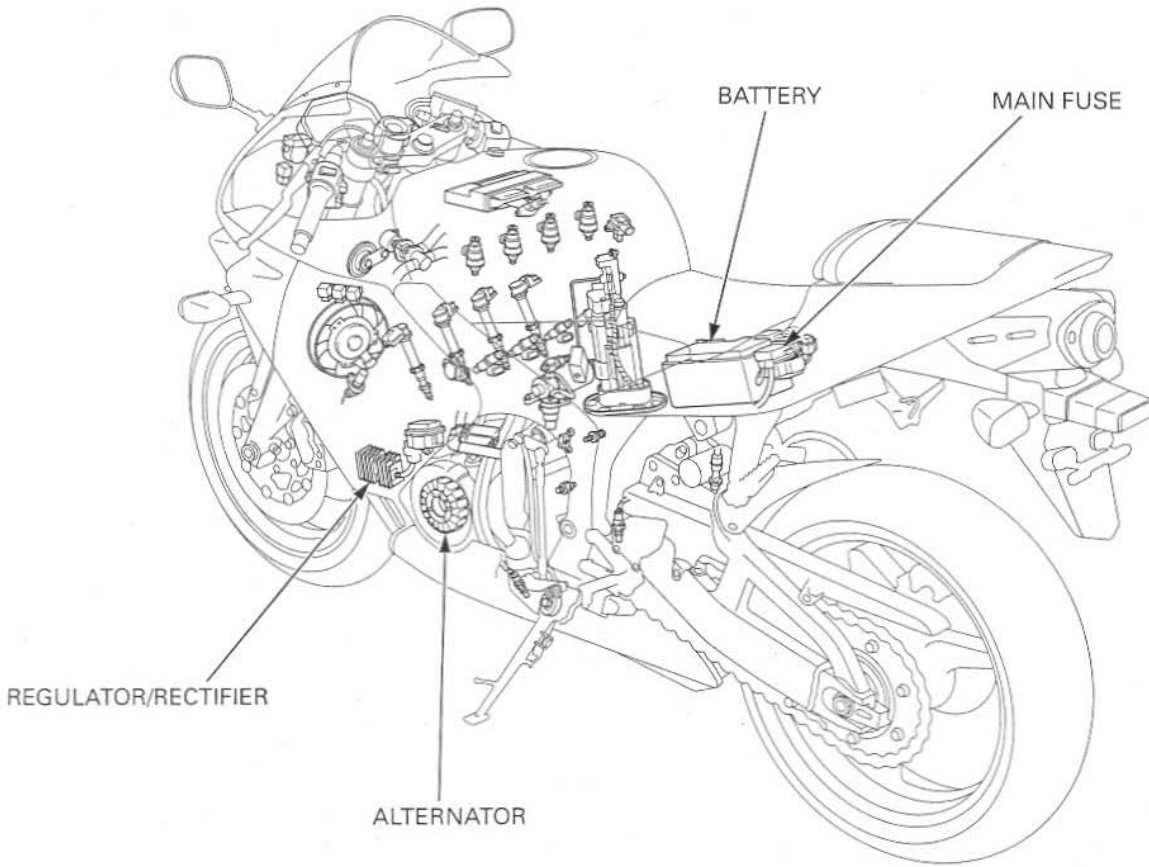

17. BATTERY/CHARGING SYSTEM

SYSTEM DIAGRAM.....	17-2	BATTERY TRAY	17-7
SERVICE INFORMATION	17-3	CHARGING SYSTEM INSPECTION.....	17-9
TROUBLESHOOTING.....	17-4	ALTERNATOR CHARGING COIL	17-9
BATTERY.....	17-5	REGULATOR/RECTIFIER	17-10

BATTERY/CHARGING SYSTEM SYSTEM DIAGRAM

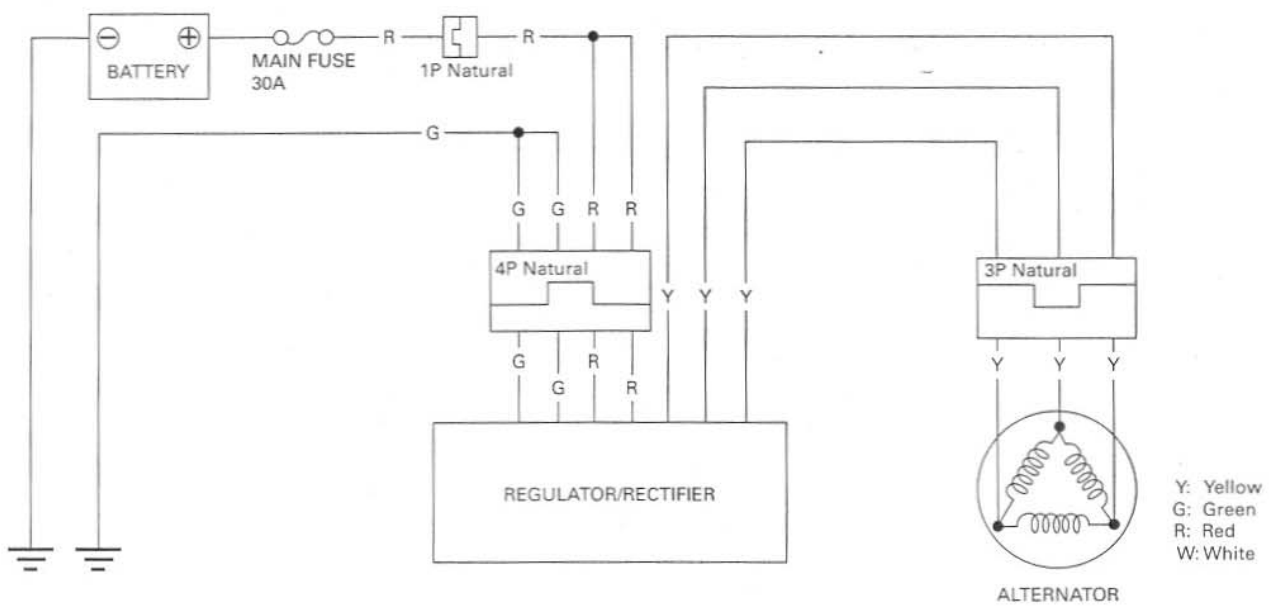
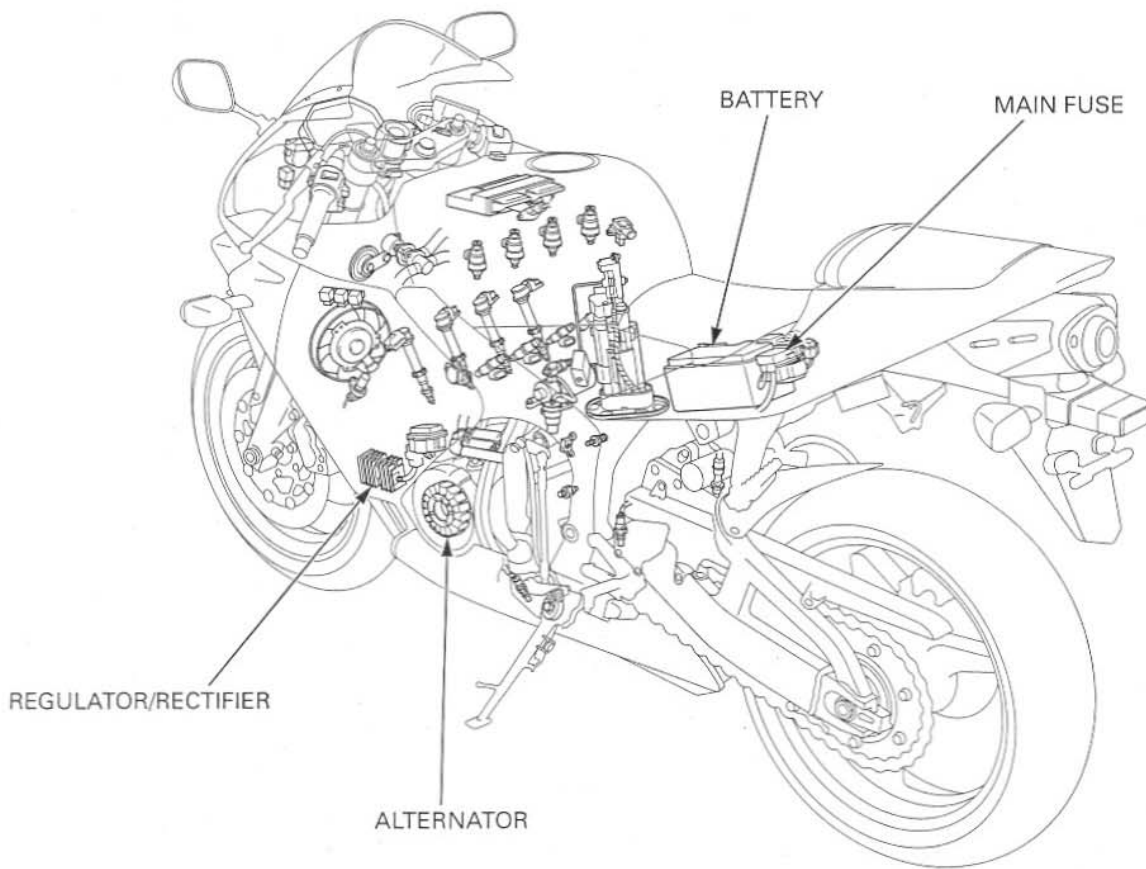

SERVICE INFORMATION

GENERAL

⚠ WARNING

- The battery gives off explosive gases; keep sparks, flames and cigarettes away. Provide adequate ventilation when charging.
- The battery contains sulfuric acid (electrolyte). Contact with skin or eyes may cause severe burns. Wear protective clothing and a face shield.
 - If electrolyte gets on your skin, flush with water.
 - If electrolyte gets in your eyes, flush with water for at least 15 minutes and call a physician immediately.
- Electrolyte is poisonous.
 - If swallowed, drink large quantities of water or milk and call your local Poison Control Center or a call a physician immediately.

NOTICE

- *Always turn off the ignition switch before disconnecting any electrical component.*
- *Some electrical components may be damaged if terminals or connectors are connected or disconnected while the ignition switch is ON and current is present.*
- For extended storage, remove the battery, give it a full charge, and store it in a cool, dry space. For maximum service life, charge the stored battery every two weeks.
- For a battery remaining in a stored motorcycle, disconnect the negative battery cable from the battery terminal.
- The maintenance free battery must be replaced when it reaches the end of its service life.
- The battery can be damaged if overcharged or undercharged, or if left to discharge for a long period. These same conditions contribute to shortening the "life span" of the battery. Even under normal use, the performance of the battery deteriorates after 2–3 years.
- Battery voltage may recover after battery charging, but under heavy load, battery voltage will drop quickly and eventually die out. For this reason, the charging system is often suspected as the problem. Battery overcharge often results from problems in the battery itself, which may appear to be an overcharging symptom. If one of the battery cells is shorted and battery voltage does not increase, the regulator/rectifier supplies excess voltage to the battery. Under these conditions, the electrolyte level goes down quickly.
- Before troubleshooting the charging system, check for proper use and maintenance of the battery. Check if the battery is frequently under heavy load, such as having the headlight and taillight ON for long periods of time without riding the motorcycle.
- The battery will self-discharge when the motorcycle is not in use. For this reason, charge the battery every two weeks to prevent sulfation from occurring.
- When checking the charging system, always follow the steps in the troubleshooting flow chart (page 17-4).
- For battery charging, do not exceed the charging current and time specified on the battery. Use of excessive current or charging time may damage the battery.
- Refer to page 11-4 for alternator removal and disassembly.

BATTERY TESTING

Refer to the instruction of the Operation Manual for the recommended battery tester. The recommended battery tester puts a "load" on the battery so that the actual battery condition of the load can be measured.

Recommended battery tester BM-210-AH (U.S.A. only) or BM-210

SPECIFICATIONS

ITEM		SPECIFICATIONS	
Battery	Capacity	12V – 8.6 Ah	
	Current leakage	2.0 mA max.	
	Voltage (20°C/68°F)	Fully charged	13.0 – 13.2 V
		Needs charging	Below 12.4 V
	Charging current	Normal	0.9 A/5 – 10 h
Quick		4.5 A/1 h	
Alternator	Capacity	0.333 kW/5,000 rpm	
	Charging coil resistance (20°C/68°F)	0.1 – 1.0 Ω	

TROUBLESHOOTING

BATTERY IS DAMAGED OR WEAK

1. BATTERY TEST

Remove the battery (page 17-5).

Check the battery condition using the recommended battery tester.

RECOMMENDED BATTERY TESTER:

BM210 or BATTERY MATE or equivalent

Is the battery in good condition?

NO – Faulty battery

YES – GO TO STEP 2.

2. CURRENT LEAKAGE TEST

Install the battery (page 17-5).

Check the battery current leakage test (Leak test; (page 17-9)).

Is the current leakage below 2.0 mA?

YES – GO TO STEP 4.

NO – GO TO STEP 3.

3. CURRENT LEAKAGE TEST WITHOUT REGULATOR/RECTIFIER CONNECTED

Disconnect the regulator/rectifier connector and recheck the battery current leakage.

Is the current leakage below 2.0 mA?

YES – Faulty regulator/rectifier

NO – • Shorted wire harness
• Faulty ignition switch

4. ALTERNATOR CHARGING COIL INSPECTION

Check the alternator charging coil (page 17-9).

Is the alternator charging coil resistance within 0.1 – 1.0 Ω (20°C/68°F)?

NO – Faulty charging coil

YES – GO TO STEP 5.

5. CHARGING VOLTAGE INSPECTION

Measure and record the battery voltage using a digital multimeter (page 17-5).

Start the engine.

Measure the charging voltage (page 17-9).

Compare the measurement to result of the following calculation.

STANDARD:

Measured battery Voltage < Measured charging voltage < 15.5 V

Is the measured charging voltage within the standard voltage?

YES – Faulty battery

NO – GO TO STEP 6.

6. REGULATOR/RECTIFIER SYSTEM INSPECTION

Check the voltage and resistance at the regulator/rectifier connector (page 17-10).

Are the results of checked voltage and resistance correct?

YES – Faulty regulator/rectifier

NO – • Open circuit in related wire
• Loose or poor contacts of related terminal
• Shorted wire harness

BATTERY

REMOVAL/INSTALLATION

Always turn the ignition switch OFF before removing the battery.

Remove the seat (page 3-4).
 Disconnect the negative cable and then the positive cable.
 Remove the battery holder band and battery.

Connect the positive terminal first and then the negative cable.

Install the battery in the reverse order of removal with the proper wiring as shown.
 After installing the battery, coat the terminals with clean grease.

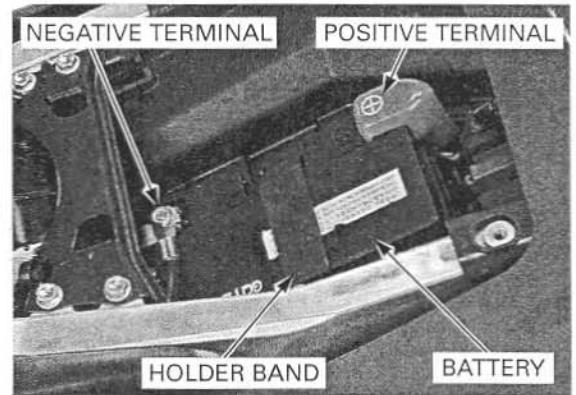

VOLTAGE INSPECTION

Measure the battery voltage using a digital multimeter.

VOLTAGE:

- Fully charged:** 13.0 – 13.2V
- Under charged:** Below 12.3V

TOOL:

Digital multimeter

Commercially available in U.S.A.

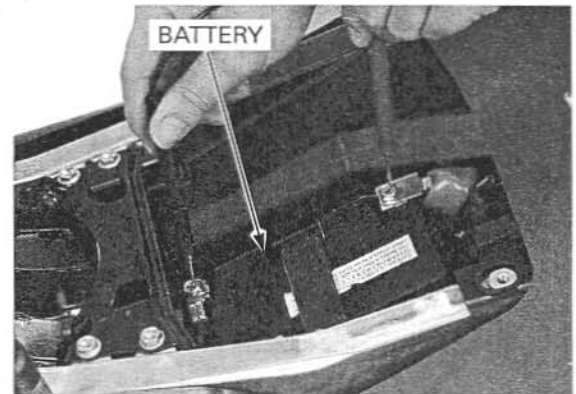

BATTERY TESTING

Always clear the work area of flammable materials such as gasoline, brake fluid, electrolyte, or cloth towels when operating the tester. The heat generated by the tester may cause a fire.

Remove the battery (see above).

Securely connect the tester's positive (+) cable first, then connect the negative (-) cable.

TOOL:

Battery tester BM-210-AH (U.S.A. only), or BM210

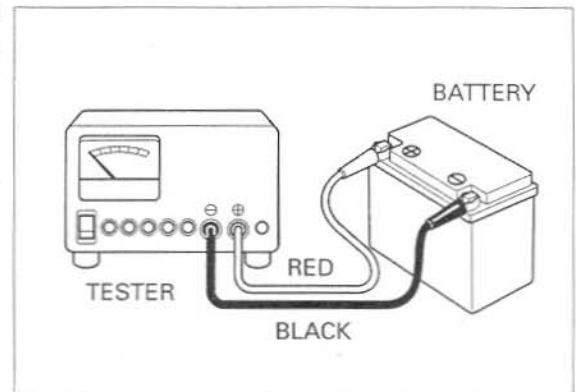

For accurate test results, be sure the tester's cables and clamps are in good working condition and that a secure connection can be made at the battery.

Set the temperature switch to "HIGH" or "LOW" depending on the ambient temperature.

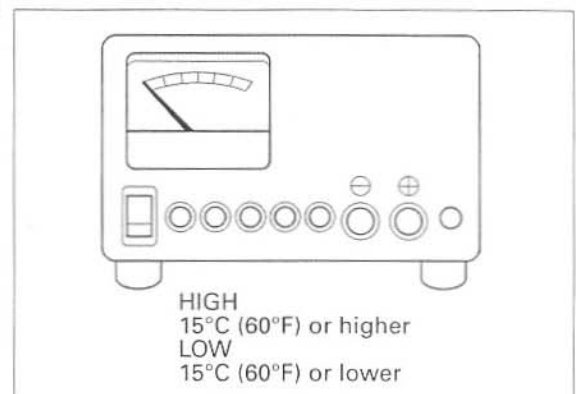

BATTERY/CHARGING SYSTEM

For the first check, DO NOT charge the battery before testing; test it in an "as is" condition.

Push in the appropriate test button for 3 seconds and read the condition of the battery on the meter.

To avoid damaging the tester, only test batteries with an amperage rating of less than 20 Ah.

Tester damage can result from overheating when:

- The test button is pushed in for more than 3 seconds.
- The tester is used without being allowed to cool for at least 1 minute when testing more than one battery.
- More than 10 consecutive tests are performed without allowing at least a 30-minute cool-down period.

The result of a test on the meter scale is relative to the amp. hour rating of the battery. ANY BATTERY READING IN THE GREEN ZONE IS OK. Batteries should only be charged if they register in the YELLOW or RED zone.

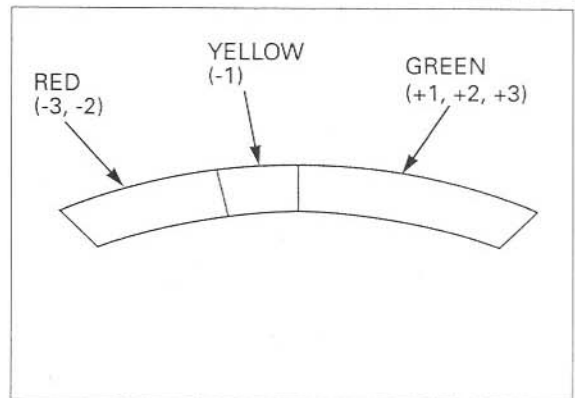
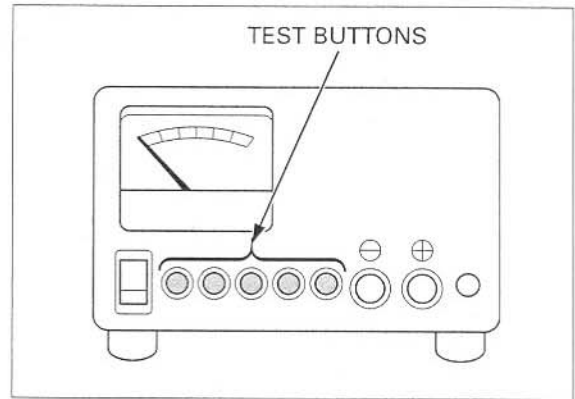

BATTERY CHARGING

Remove the battery (page 17-5).

- Clean the battery terminals and position the battery as far away from the charger as the leads will permit.
- Do not place batteries below the charger-gases from the battery may corrode and damage the charger.
- Do not place batteries on top of the charger. Be sure the air vents are not blocked.

TOOL:

Christie battery charger MC1012/2 (U.S.A. only)

1. Turn the Power Switch to the OFF position.
2. Set the battery Amp. Hr. Selector Switch for the size of the battery being charged.
3. Set the Timer to the position indicated by the Honda Battery Tester; RED-3, RED-2, or YELLOW 1. If you are charging a new battery, set the switch to the NEW BATT position.
4. Attach the clamps to the battery terminals; RED to Positive, BLACK to Negative.

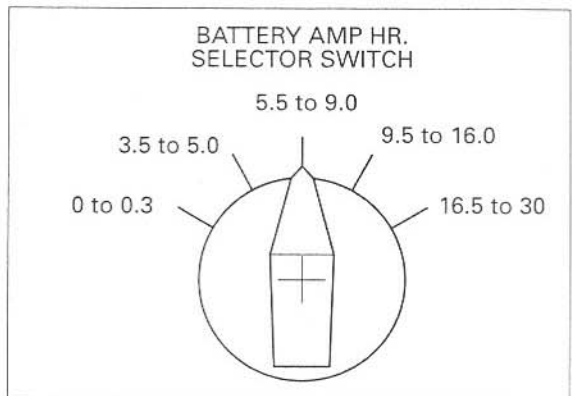
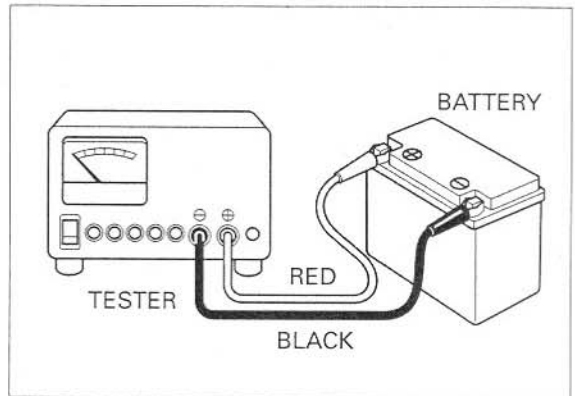

BATTERY/CHARGING SYSTEM

Connect the battery cables only when the Power switch is OFF.

5. Turn the Power Switch to the ON position.
6. When the timer reaches the "Trickle" position, the charging cycle is complete. Turn the Power Switch OFF and disconnect the clamps.
7. Let the battery cool for at least 10 minutes or until gassing subsides after charging.
8. Reset the battery using the Honda Battery Tester and recharge if necessary using the above steps.

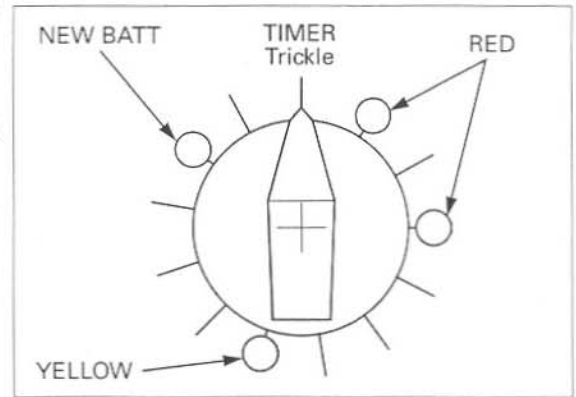

BATTERY TRAY

REMOVAL/INSTALLATION

Remove the following:

- Rear fender (page 3-16)
- Muffler (page 3-20)
- Battery (page 17-5)
- Fuel tank (page 6-61)

Remove the two socket bolts and left footpeg bracket.

Remove the battery tray mounting bolts.

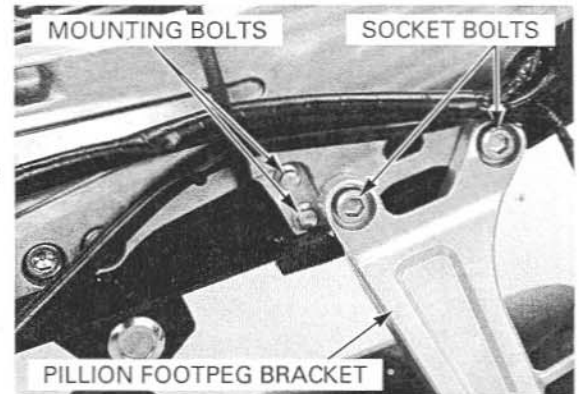

Remove the battery tray front mounting screw and bolt.

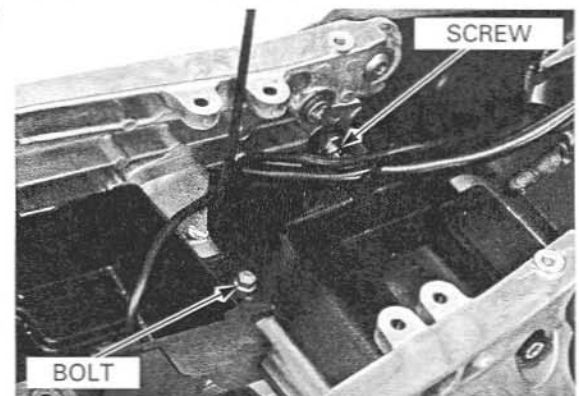

Remove the battery tray rear mounting screw.

Remove the starter relay and fuse box from the battery tray.

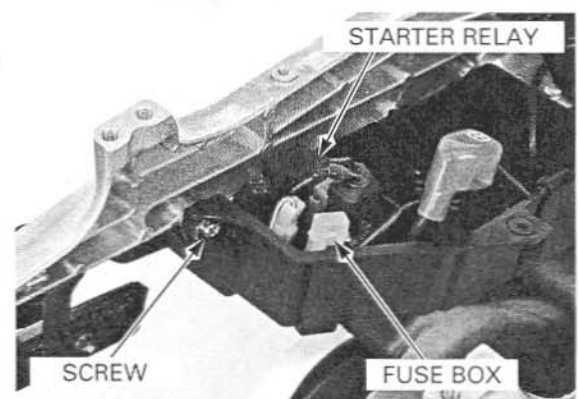

BATTERY/CHARGING SYSTEM

Remove the battery tray from the seat rail by pulling it backward.

Installation is in the reverse order of removal.

NOTE:

When installing the battery tray, align the battery tray bosses with the seat rail grooves.

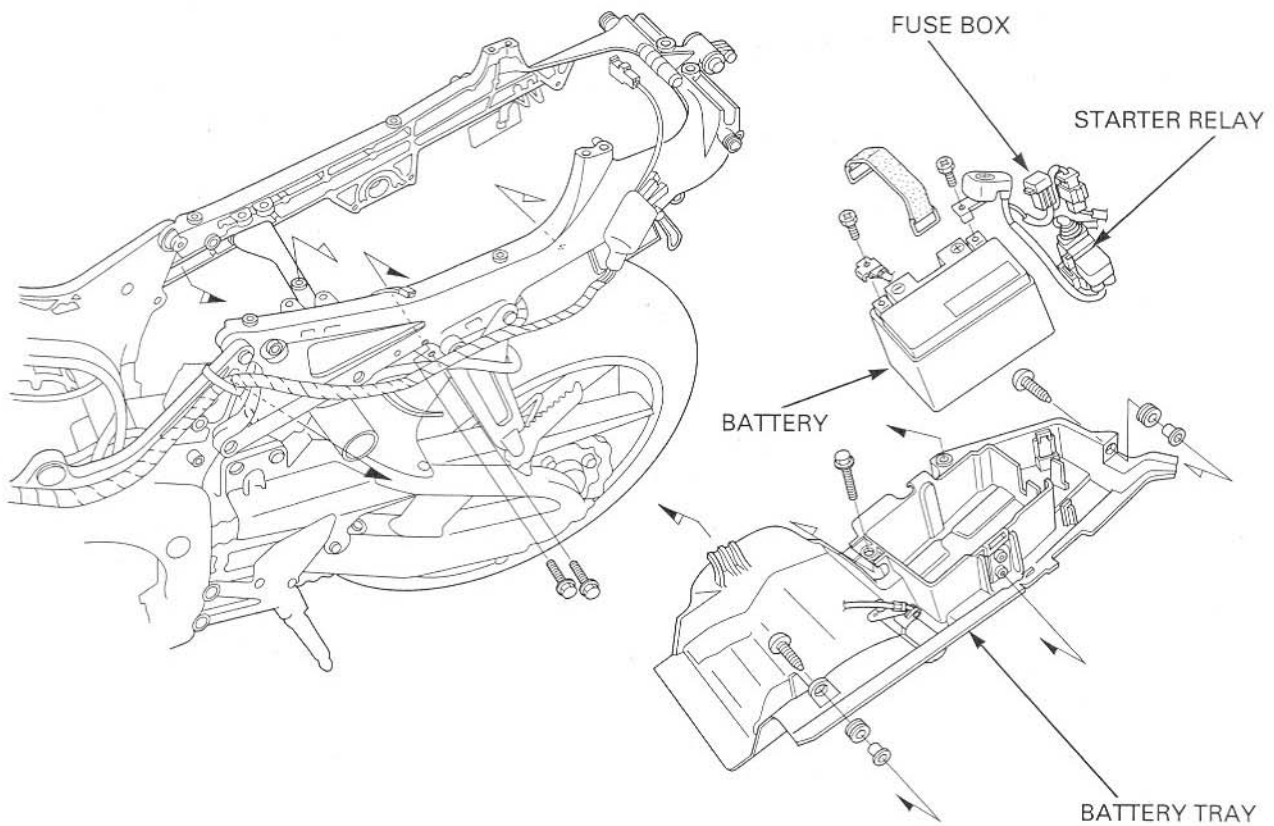
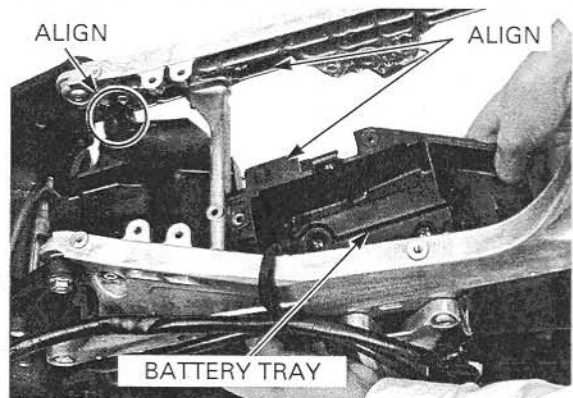

CHARGING SYSTEM INSPECTION

CURRENT LEAKAGE INSPECTION

Remove the seat (page 3-4).

Turn the ignition switch off and disconnect the battery negative cable from the battery.

Connect the ammeter (+) probe to the ground cable and the ammeter (-) probe to the battery (-) terminal.

With the ignition switch off, check for current leakage.

- When measuring current using a tester, set it to a high range, and then bring the range down to an appropriate level. Current flow higher than the range selected may blow out the fuse in the tester.
- While measuring current, do not turn the ignition switch on. A sudden surge of current may blow out the fuse in the tester.

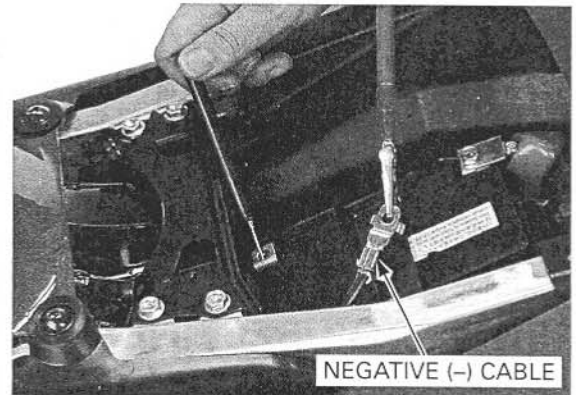

SPECIFIED CURRENT LEAKAGE: 2.0 mA max.

If current leakage exceeds the specified value, a short circuit is likely.

Locate the shorted circuit by disconnecting connections one by one and measuring the current.

CHARGING VOLTAGE INSPECTION

Be sure the battery is in good condition before performing this test.

Warm the engine to normal operating temperature. Stop the engine, and connect the multimeter between the positive and negative terminals of the battery.

- To prevent a short, make absolutely certain which are the positive and negative terminals or cable.

Restart the engine.

With the headlight on Hi beam, measure the voltage on the multimeter when the engine runs at 5,000 rpm.

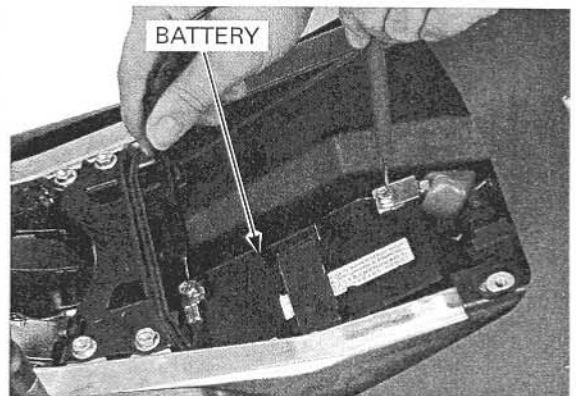

Standard: Measured battery voltage (page 17-5) < Measured charging voltage (page 17-9) < 15.5 V at 5,000 rpm

ALTERNATOR CHARGING COIL

It is not necessary to remove the stator coil to make this test.

INSPECTION

Remove the following:

- Lower cowls (page 3-6)
- Middle cowls (page 3-7)

Disconnect the alternator 3P (Natural) connector.

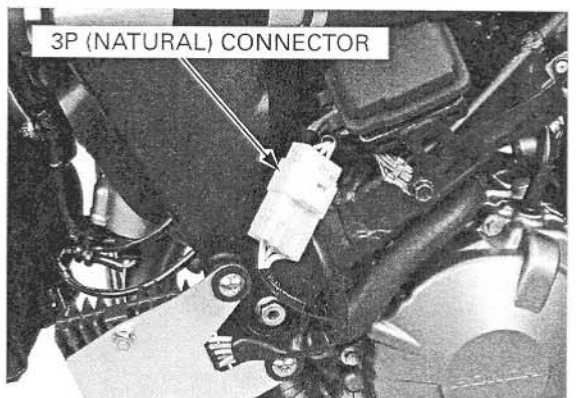

BATTERY/CHARGING SYSTEM

Check the resistance between all three Yellow terminals.

STANDARD: 0.1 – 1.0 Ω (at 20°C/68°F)

Check for continuity between all three Yellow terminals and Ground. There should be no continuity.

If readings are far beyond the standard, or if any wire has continuity to ground, replace the alternator stator.

Refer to page 11-4 for stator removal.

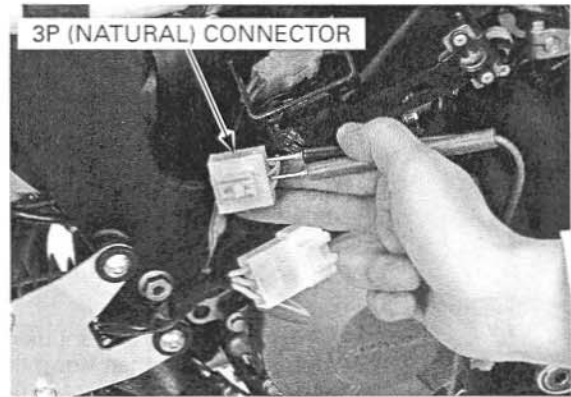

REGULATOR/RECTIFIER

It is not necessary to remove the stator coil to perform this test.

SYSTEM INSPECTION

Remove the following:

- Lower cowls (page 3-6)
- Middle cowls (page 3-7)

Disconnect the regulator/rectifier 4P (Natural) connector and alternator 3P (Natural) connector, and check it for loose contact or corroded terminals.

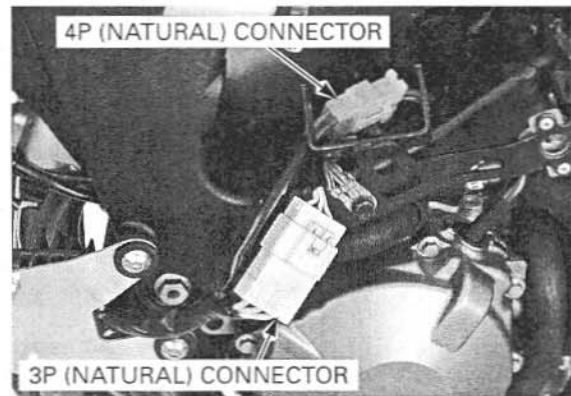

If the regulated voltage reading (page 17-3) is out of the specification, measure the voltage between connector terminals (wire harness side) as follow:

Item	Terminal	Specification
Battery charging line	Red (+) and ground (-)	Battery voltage should appear
Charging coil line	Yellow and Yellow	0.1 – 1.0 Ω at (20°C/68°F)
Ground line	Green and ground	Continuity should exist

If all components of the charging system are normal and there are no loose connections at the regulator/rectifier connectors, replace the regulator/rectifier unit.

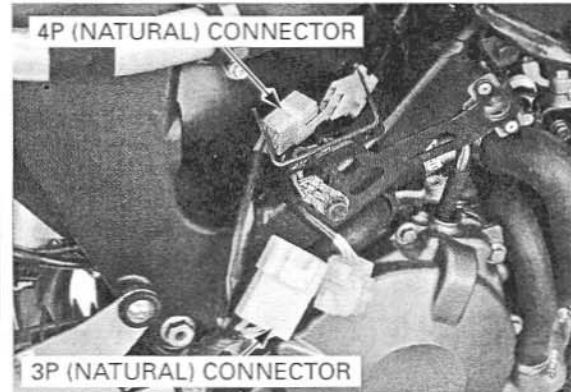

REMOVAL/INSTALLATION

Disconnect the alternator 3P (Natural) connector.
Disconnect the regulator/rectifier 4P (Natural) connector.

Remove the bolts and regulator/rectifier unit stay.

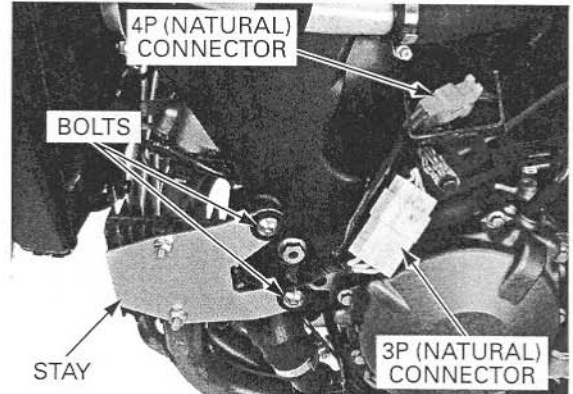

Remove the bolts, nuts and regulator/rectifier unit from the mounting stay.

Install the regulator/rectifier unit in the reverse order of removal.

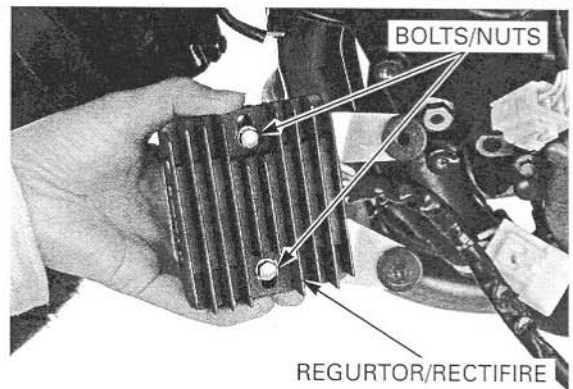

18. IGNITION SYSTEM

SYSTEM DIAGRAM.....	18-2	IGNITION SYSTEM INSPECTION.....	18-5
SERVICE INFORMATION	18-3	IGNITION PULSE GENERATOR.....	18-7
TROUBLESHOOTING.....	18-4	IGNITION TIMING	18-7

IGNITION SYSTEM SYSTEM DIAGRAM

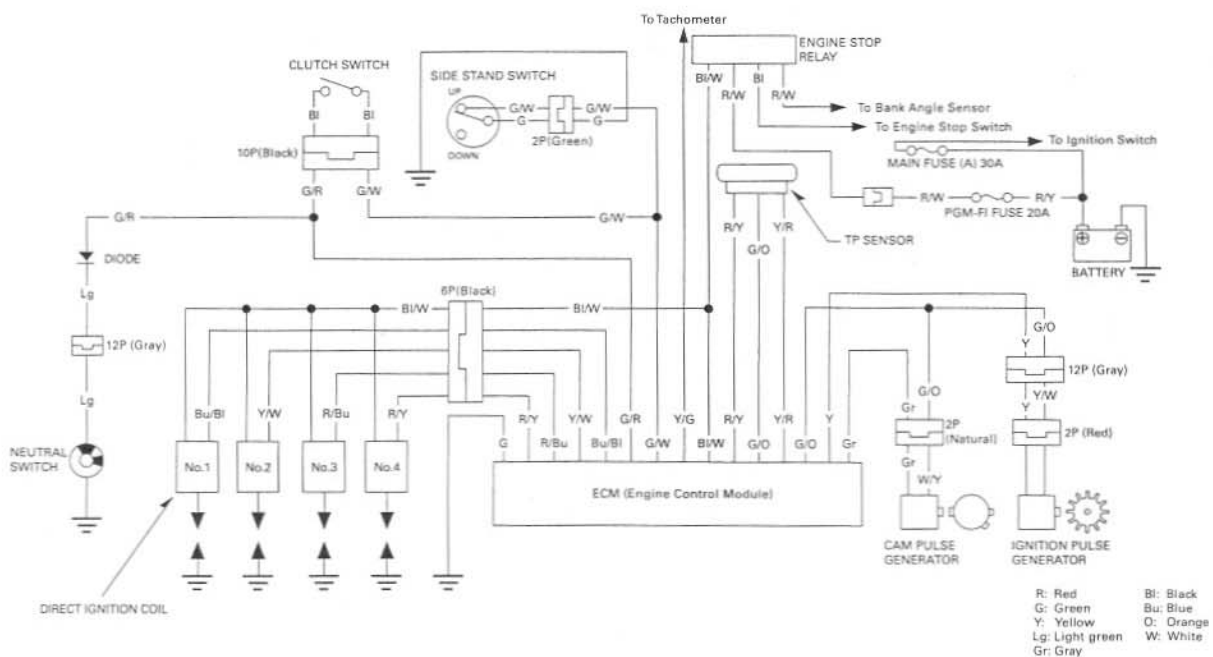
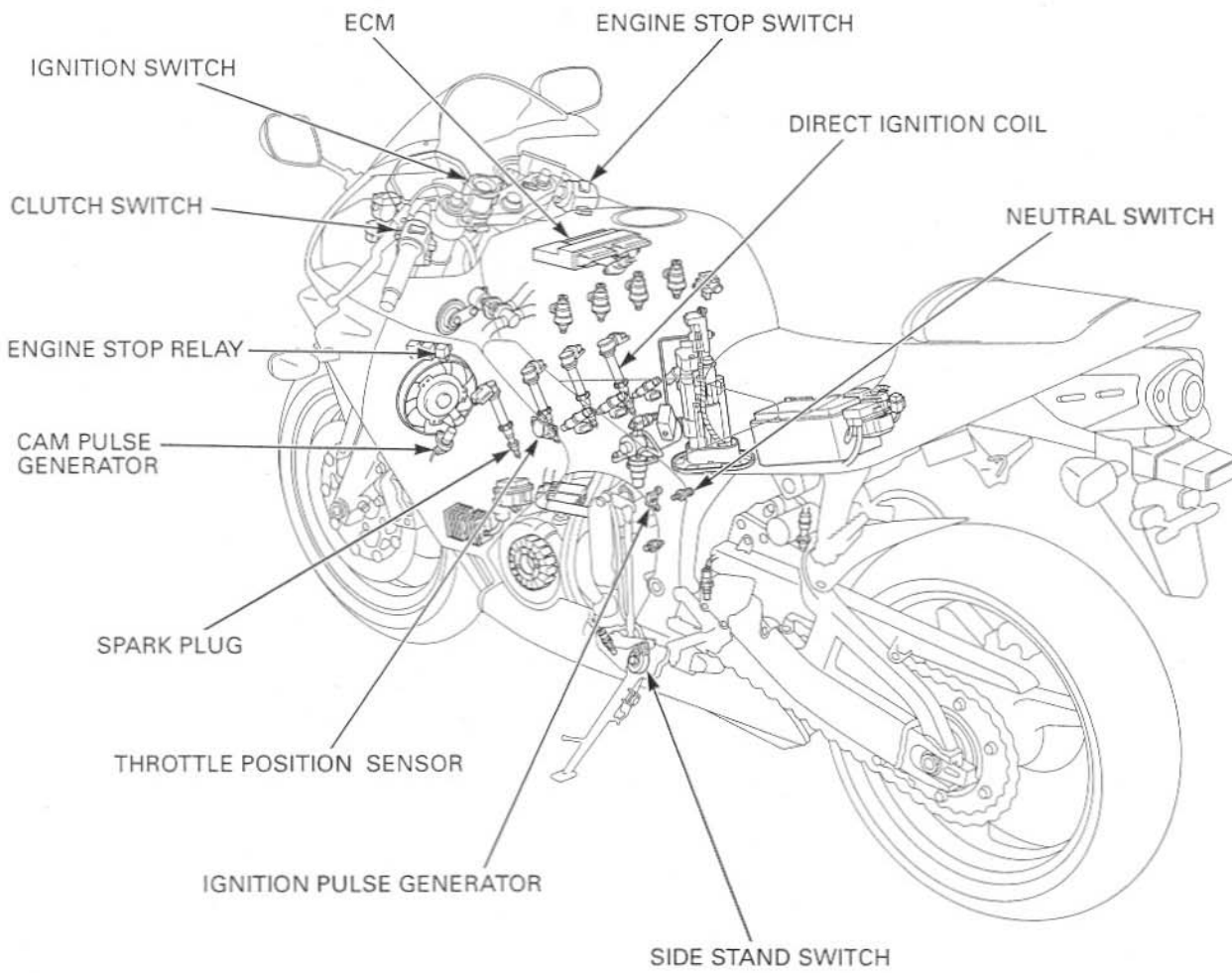

SERVICE INFORMATION

GENERAL

NOTICE

- The ECM may be damaged if dropped. Also if the connector is disconnected when current is flowing, the excessive voltage may damage the module. Always turn off the ignition switch before servicing.
- Use spark plug of the correct heat range. Using spark plug with an incorrect heat range can damage the engine.
- Some electrical components may be damaged if terminals or connectors are connected or disconnected while the ignition switch is ON and current is present.
- When servicing the ignition system, always follow the steps in the troubleshooting sequence (page 18-4).
- This motorcycle's Ignition Control Module (ICM) is built into the Engine Control Module (ECM).
- The ignition timing does not normally need to be adjusted since the ECM is factory preset.
- A faulty ignition system is often related to poor connections. Check those connections before proceeding. Make sure the battery is adequately charged. Using the starter motor with a weak battery results in a slower engine cranking speed as well as no spark at the spark plug.
- This motorcycle features direct ignition coils, where the ignition coil and spark plug cap are integrated. There are four direct ignition coils.
- Refer to the Throttle Position (TP) sensor inspection (page 6-91), cam pulse generator inspection (page 6-90) and ECM inspection (page 6-94).

SPECIFICATIONS

ITEM	SPECIFICATIONS
Spark plug (Iridium)	IMR9C-9HE (NGK)
Spark plug gap	0.80 – 0.90 mm (0.031 – 0.035 in)
Ignition coil peak voltage	100 V minimum
Ignition pulse generator peak voltage	0.7 V minimum
Ignition timing ("F"mark)	15° BTDC at idle

TORQUE VALUES

Timing hole cap	18 N·m (1.8 kgf·m, 13 lbf·ft)	Apply grease to the threads
Spark plug	16 N·m (1.6 kgf·m, 12 lbf·ft)	
Stator wire clamp bolt	14 N·m (1.4 kgf·m, 10 lbf·ft)	CT bolt

TOOLS

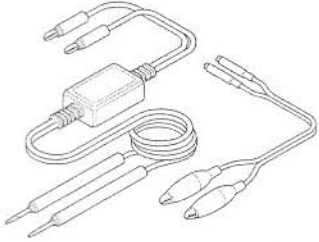
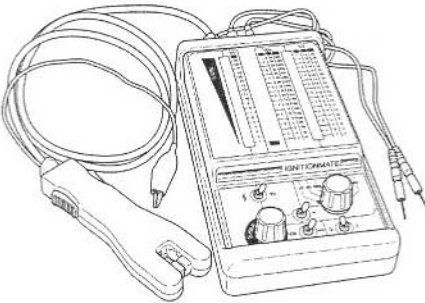
<p>Peak voltage adaptor 07HGJ-0020100 (not available in U.S.A.)</p>  <p>with commercially available digital multimeter (impedance 10 MΩ/DCV minimum)</p>	<p>IgnitionMate Peak voltage tester MTP07-0286 (U.S.A. only)</p> 
---	---

IGNITION SYSTEM

TROUBLESHOOTING

- Inspect the following before diagnosing the system.
 - Faulty spark plug
 - Loose direct ignition coil and spark plug connection
 - Loose direct ignition coil connectors
 - Water got into the direct ignition coil (shorting the ignition coil secondary voltage)
- If there is no spark at any cylinder, temporarily exchange the direct ignition coil with the other good one and perform the spark test. If there is spark, the exchanged direct ignition coil is faulty.
- "Initial voltage" of the ignition primary coil is the battery voltage with the ignition switch turned ON and engine stop switch turned " \curvearrowright " (The engine is not cranked by the starter motor).

No spark at all plugs

	Unusual condition	Probable cause (Check in numerical order)
Ignition coil primary voltage	No initial voltage with the ignition ON and engine stop switches turned " \curvearrowright " (other electrical components are normal)	<ol style="list-style-type: none"> 1. Faulty engine stop switch. 2. An open circuit in Black/white wire between the direct ignition coil and ECM. 3. Loose or poor connect of the direct ignition coil primary wire terminal, or an open circuit in primary coil (Check at the ECM connector). 4. Faulty ECM (in case when the initial voltage is normal while disconnecting ECM connector)
	Initial voltage is normal, but it drops down to 2 – 4 V while cranking the engine.	<ol style="list-style-type: none"> 1. Incorrect peak voltage adaptor connections. 2. Undercharged battery. 3. No voltage between the Black/white (+) and body ground (-) at the ECM multi-connector or loosen ECM connection. 4. An open circuit or loose connection in Green wire. 5. An open circuit or loose connection in Blue/black, Yellow/white, Red/blue and Red/yellow wires between the direct ignition coils and ECM. 6. Faulty side stand switch or neutral switch. 7. An open circuit or loose connection in No.7 related circuit wires. <ul style="list-style-type: none"> – Side stand switch line: Green/white wire – Neutral switch line:Light Green wire 8. Faulty ignition pulse generator (measure the peak voltage). 9. Faulty ECM (in case when above No. 1 – 8 are normal).
	Initial voltage is normal, but no peak voltage while cranking the engine.	<ol style="list-style-type: none"> 1. Faulty peak voltage adaptor connections. 2. Faulty peak voltage adaptor. 3. Faulty ECM (in case when above No.1, 2 are normal).
	Initial voltage is normal, but peak voltage is lower than standard value.	<ol style="list-style-type: none"> 1. The multimeter impedance is too low; below 10 MΩ/DCV. 2. Cranking speed is too low (battery under charged). 3. The sampling timing of the tester and measured pulse were not synchronized (system is normal if measured voltage is over the standard voltage at least once). 4. Faulty ECM (in case when above No. 1 – 3 are normal).
	Initial and peak voltage are normal, but does not spark.	<ol style="list-style-type: none"> 1. Faulty spark plug or leaking ignition coil secondary current ampere. 2. Faulty direct ignition coil (s).
Ignition pulse generator	Peak voltage is lower than standard value.	<ol style="list-style-type: none"> 1. The multimeter impedance is too low; below 10 MΩ/DCV. 2. Cranking speed is too low (battery under charged). 3. The sampling timing of the tester and measured pulse were not synchronized (system is normal if measured voltage is over the standard voltage at least once). 4. Faulty ECM (in case when above No. 1 – 3 are normal).
	No peak voltage.	<ol style="list-style-type: none"> 1. Faulty peak voltage adaptor. 2. Faulty ignition pulse generator.

IGNITION SYSTEM INSPECTION

- If there is no spark at any plug, check all connections for loose or poor contact before measuring each peak voltage.
- Use recommended digital multimeter or commercially available digital multimeter with an impedance of 10 M Ω /DCV minimum.
- The display value differs depending upon the internal impedance of the multimeter.
- If the Imrie diagnostic tester (model 625) is used, follow the manufacturer's instruction.

Connect the peak voltage tester or peak voltage adaptor to the digital multimeter.

TOOLS:

IgnitionMate peak voltage tester MTP07-0286 (U.S.A. only) or 07HGJ-0020100 (not available in U.S.A.)

Peak voltage adaptor

with commercially available digital multimeter (impedance 10 M Ω /DCV minimum)

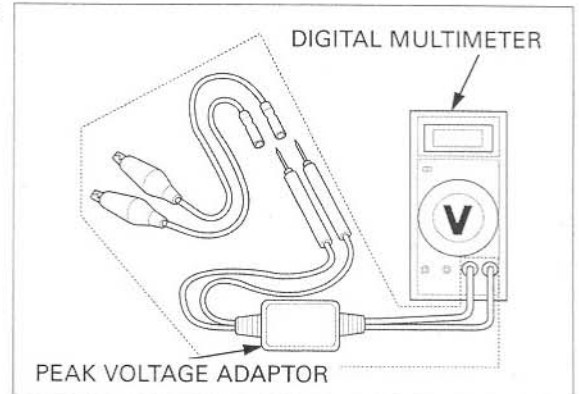

IGNITION COIL PRIMARY PEAK VOLTAGE

- Check all system connections before inspection. If the system is disconnected, incorrect peak voltage might be measured.
- Check cylinder compression and check that the spark plugs are installed correctly.

Disconnect the direct ignition coils from the spark plugs (page 4-7).

Connect the direct ignition coil 2P connectors to the direct ignition coil.

Shift the transmission into neutral.

Connect a known-good spark plug to the direct ignition coil and ground the spark plug to the cylinder head as done in a spark test.

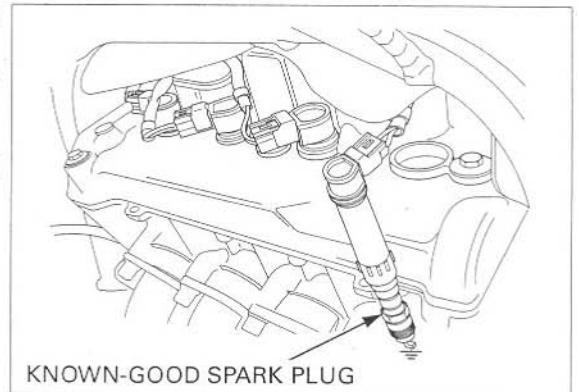

With the ignition coil 6P (Black) connector connected, connect the peak voltage adaptor or peak voltage tester to the 6P (Black) connector primary wire terminal and ground.

CONNECTION:

No.1 coil:

Blue/black terminal (+) – Body ground (-)

No.2 coil:

Yellow/white terminal (+) – Body ground (-)

No.3 coil:

Red/blue terminal (+) – Body ground (-)

No.4 coil:

Red/yellow terminal (+) – Body ground (-)

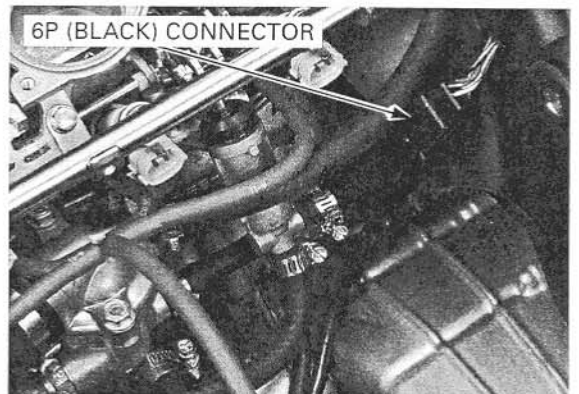

IGNITION SYSTEM

Avoid touching the spark plugs and tester probes to prevent electric shock.

Turn the ignition switch ON and engine stop switch " \odot ".
Check for initial voltage at this time.
Battery voltage should be present.
If the initial voltage cannot be measured, check the power supply circuit (refer to the troubleshooting, page 18-4).

Crank the engine with the starter motor and read the ignition coil primary peak voltage.

PEAK VOLTAGE: 100V minimum

If the peak voltage is abnormal, check for an open circuit or poor connection in Blue/black, Yellow/white, Red/blue and Red/yellow wires.
If not defects are found in the harness, refer to the troubleshooting chart on (page 18-4).

IGNITION PULSE GENERATOR PEAK VOLTAGE

- Check all system connections before inspection.
If the system is disconnected, incorrect peak voltage might be measured.
- Check cylinder compression and check that the spark plugs are installed correctly.

Remove the fuel tank cover (page 3-15).

Disconnect the ECM 32P (Light gray) connector from the ECM.

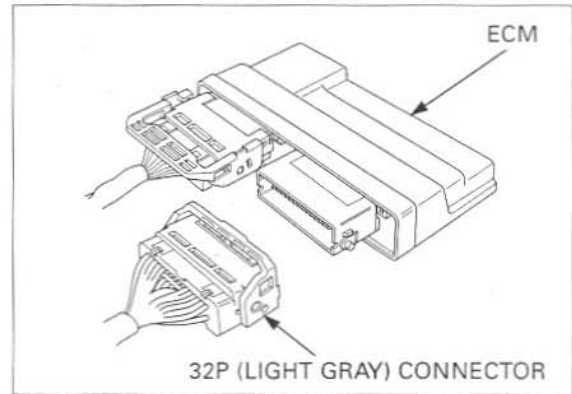

Connect the peak voltage tester or peak voltage adaptor probes to the connector terminal of the wire harness side.

TOOLS:

IgnitionMate peak voltage tester MTP07-0286
(U.S.A. only) or
07HGJ-0020100
(not available in
U.S.A.)

Peak voltage adaptor

with commercially available digital multimeter
(impedance 10 M Ω /DCV minimum)

CONNECTION:

Yellow terminal (+) – Ground (-)

Crank the engine with the starter motor and read the peak voltage.

PEAK VOLTAGE: 0.7 V minimum

If the peak voltage measured at ECM connector is abnormal, measure the peak voltage at the ignition pulse generator connector.

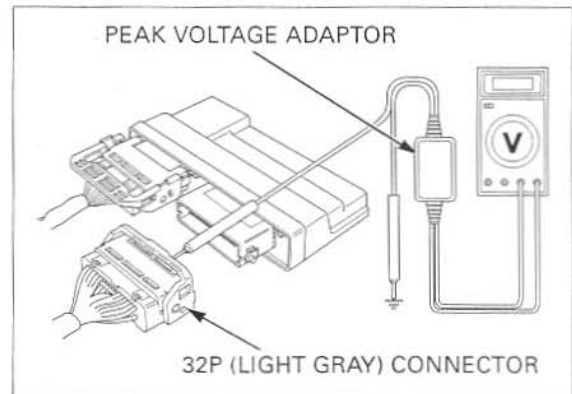

Lift and support the fuel tank (page 6-61)

Disconnect the ignition pulse generator 2P (Red) connector and connect the tester probes to the terminal (Yellow and Yellow/white).

In the same manner as at the ECM connector, measure the peak voltage and compare it to the voltage measured at the ECM connector.

- If the peak voltage measured at the ECM is abnormal and the one measured at the ignition pulse generator is normal, check the 2P (Red) connector for loose connection and the wire harness for an open circuit or loose connection.
- If both peak voltage measured are abnormal, check each item in the troubleshooting chart (page 18-4). If all items are normal, the ignition pulse generator is faulty. See following steps for ignition pulse generator replacement.

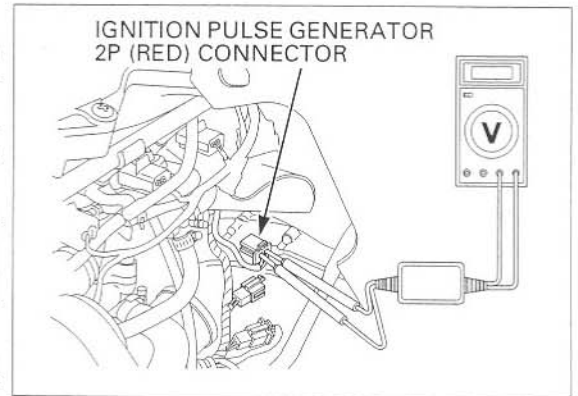

IGNITION PULSE GENERATOR

REPLACEMENT

Remove the right crankcase cover (page 10-5).

Remove the wire grommet from the cover.

Remove the bolts and ignition pulse generator.

Apply sealant to the grommet seating surface.

Install a new ignition pulse generator and the grommet into the cover groove properly.

Apply locking agent to the threads of the bolts. Tighten the bolts securely.

Install the right crankcase cover (page 10-24).

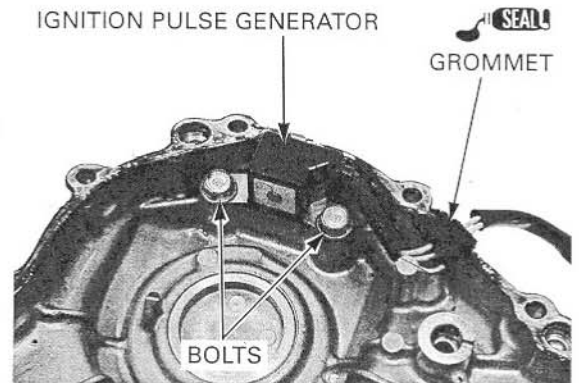

IGNITION TIMING

Remove the following:

- Lower cowls (page 3-6)
- Middle cowls (page 3-7)

Warm up the engine.

Stop the engine and remove the timing hole cap.

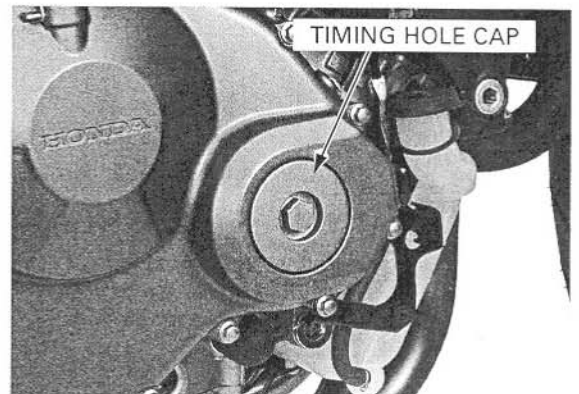

IGNITION SYSTEM

Read the instructions for timing light operation.

Connect the timing light to the No.1 direct ignition coil connector wire.

Start the engine, let it idle and check the ignition timing.

IDLE SPEED: 1,300 ± 100 rpm

The ignition timing is correct if the index mark on the right crankcase cover aligns between the "F" mark and three punch marks on the ignition pulse generator rotor as shown.

Increase the engine speed by turning the throttle stop screw and mark sure the "F" mark begins to move counterclockwise when the engine speed is approximately 2,500 rpm.

Apply oil to the O-ring.

Check the O-ring is in good condition, replace it if necessary.

Apply grease to the timing hole cap threads and install the O-ring and timing hole cap.

Tighten the timing hole cap to the specified torque.

TORQUE: 18 N·m (1.8 kgf·m, 13 lbf·ft)

Install the following:

- Middle cowls (page 3-8)
- Lower cowls (page 3-6)

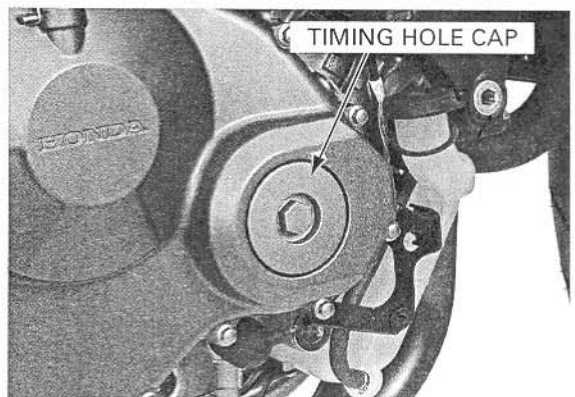
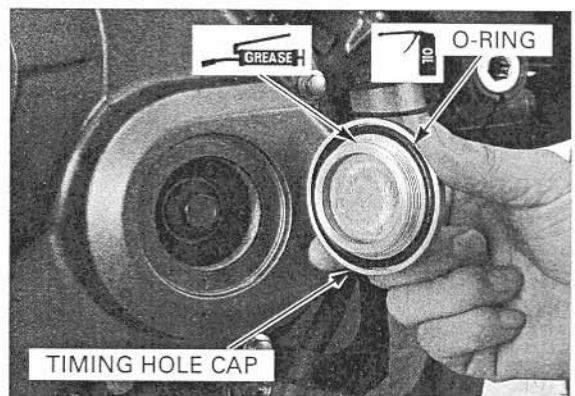
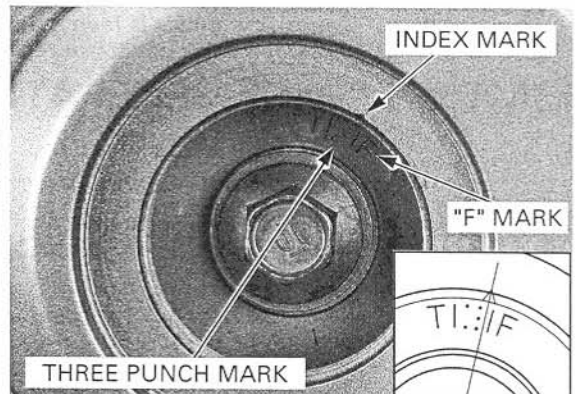
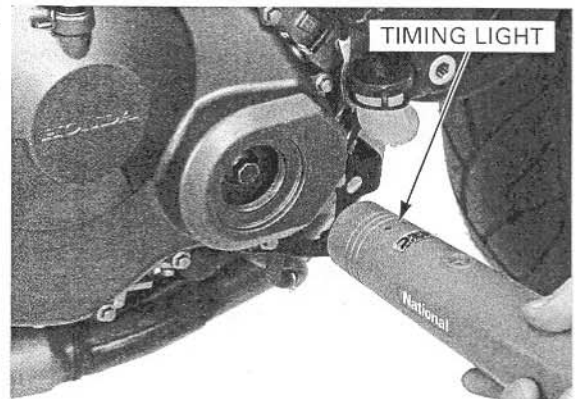

19. ELECTRIC STARTER

SYSTEM DIAGRAM.....	19-2	STARTER MOTOR.....	19-6
SERVICE INFORMATION	19-3	STARTER RELAY SWITCH.....	19-12
TROUBLESHOOTING	19-4	DIODE.....	19-14

ELECTRIC STARTER

SYSTEM DIAGRAM

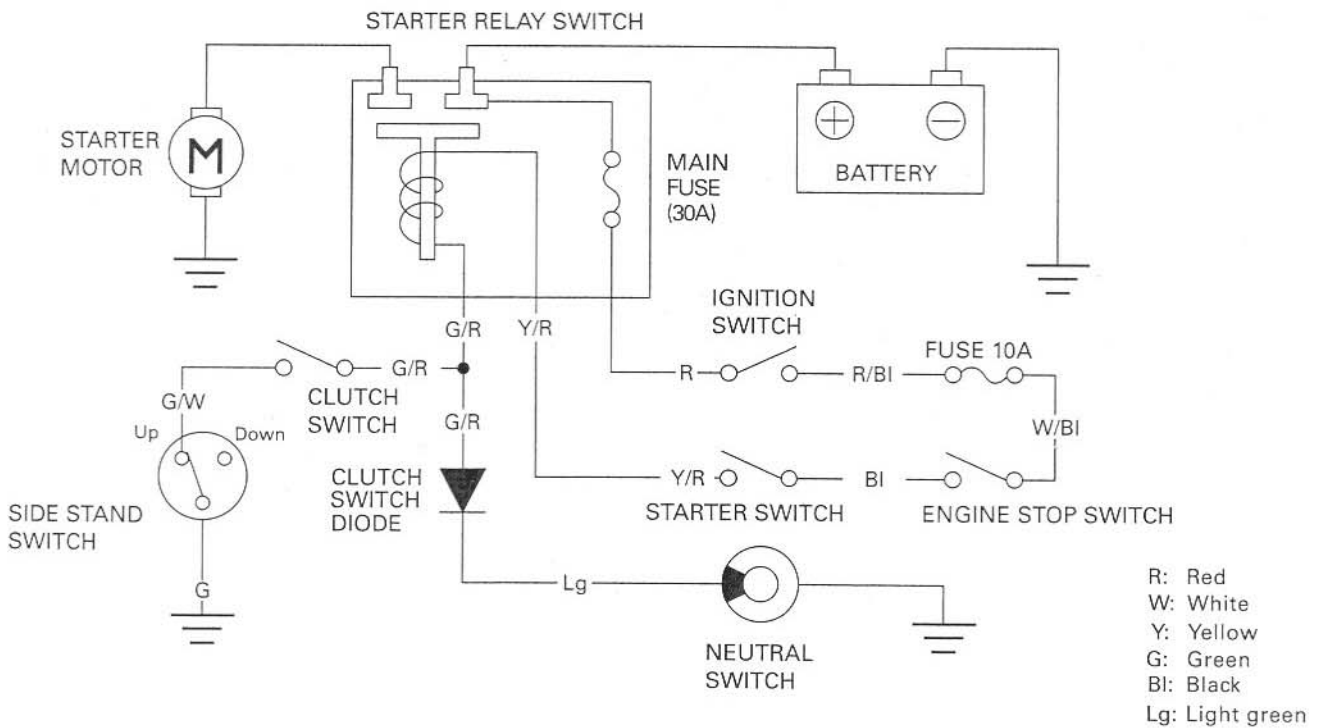
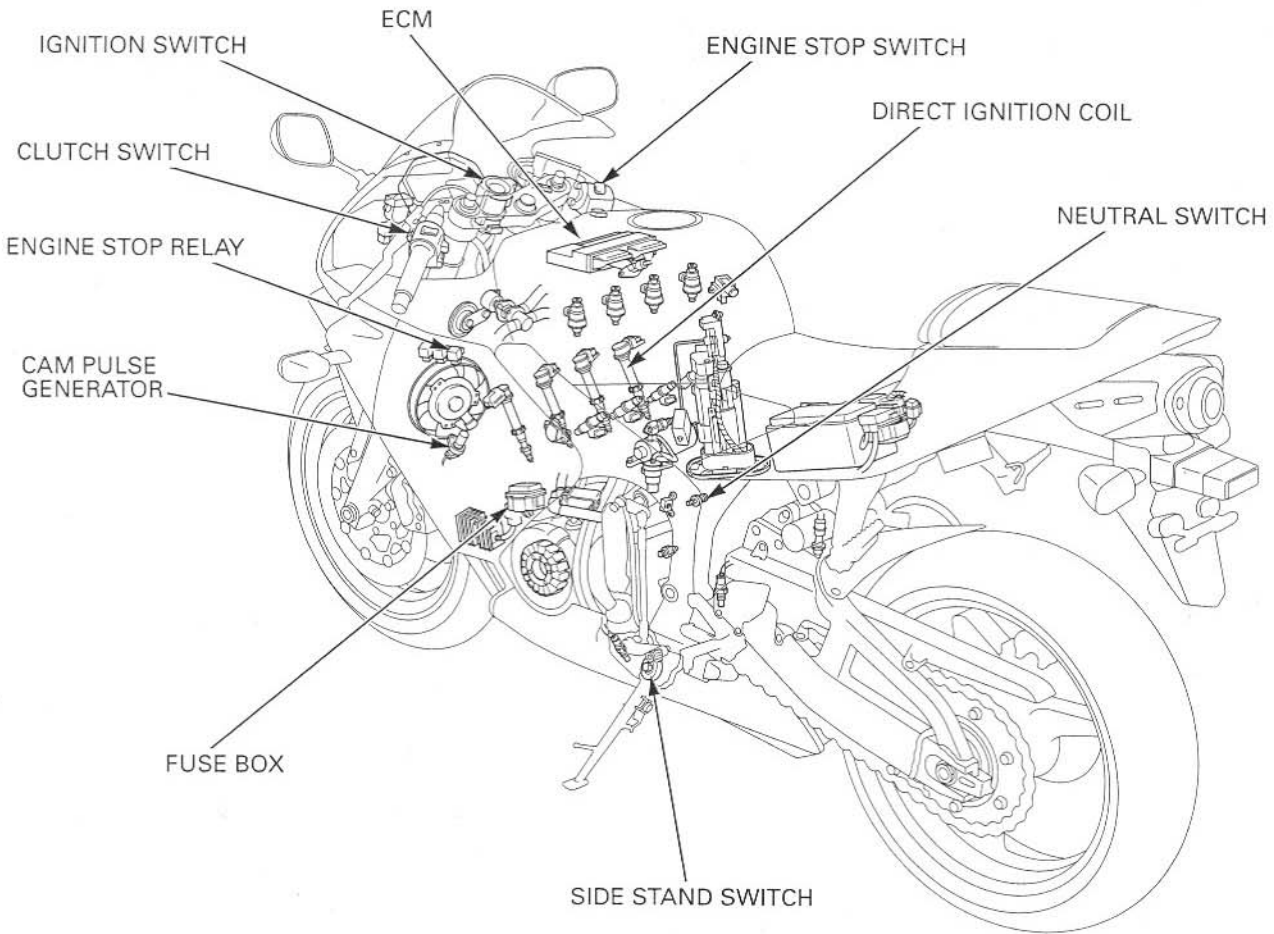

SERVICE INFORMATION

GENERAL

NOTICE

If current is kept flowing through the starter motor to turn it while the engine is not cranking over, the starter motor may be damaged.

- Always turn the ignition switch OFF before servicing the starter motor. The motor could suddenly start, causing serious injury.
- The starter motor can be serviced with the engine in the frame.
- When checking the starter system, always follow the steps in the troubleshooting flow chart (page 19-4).
- A weak battery may be unable to turn the starter motor quickly enough, or supply adequate ignition current.
- Refer to the starter clutch servicing (page 10-17).
- Refer to the following components informations.
 - Ignition switch (page 20-19)
 - Engine stop switch (page 20-20)
 - Starter switch (page 20-20)
 - Neutral switch (page 20-22)
 - Side stand switch (page 20-22)
 - Clutch switch (page 20-21)

SPECIFICATIONS

Unit: mm (in)

ITEM	STANDARD	SERVICE LIMIT
Starter motor brush length	12.0 – 13.0 (0.47 – 0.51)	6.5 (0.26)

TORQUE VALUES

Starter motor terminal nut 12 N·m (1.2 kgf·m, 9 lbf·ft)

ELECTRIC STARTER

TROUBLESHOOTING

Starter motor does not turn

1. Fuse Inspection

Check for blown main fuse or sub fuse.

Is the fuse blown?

YES – Replace the fuse

NO – GO TO STEP 2.

2. Battery Inspection

Make sure the battery is fully charged and in good condition.

Is the battery in good condition?

YES – GO TO STEP 3.

NO – Replace the battery

3. Starter Relay Switch Operation

Check the starter relay switch operation.

You should hear the relay "CLICK" when the starter switch button is depressed.

Is there a "CLICK"?

YES – GO TO STEP 4.

NO – GO TO STEP 5.

4. Starter Motor Inspection

Apply battery voltage to the starter motor directly and check the operation.

Does the starter motor turn?

YES – • Poorly connected starter motor cable
• Faulty starter relay switch (page 19-12)

NO – Faulty starter motor (page 19-6)

5. Relay Coil Ground Wire Lines Inspection

Disconnect the starter relay switch connector, and check the relay coil ground wire lines as below for continuity:

1. Green/red terminal – clutch switch diode – neutral switch line (with the transmission in neutral and clutch lever released).
2. Green/red terminal – clutch switch – side stand switch line (in any gear except neutral, and with the clutch lever pulled in and the side stand up).

Is there continuity?

NO – • Faulty neutral switch (page 20-22)
• Faulty neutral diode (page 19-14)
• Faulty clutch diode (page 19-14)
• Faulty clutch switch (page 20-21)
• Faulty side stand switch (page 20-22)
• Loose or poor contact connector
• Open circuit in wire harness

YES – GO TO STEP 6.

6. Starter Relay Voltage Inspection

Connect the starter relay switch connector.

With the ignition switch ON and the starter switch pushed, measure the voltage at the starter relay switch connector (between Yellow/red (+) and body ground (-)).

Is the starter relay switch operation correct?

NO – • Faulty ignition switch (page 20-19)
• Faulty starter switch (page 20-20)
• Faulty engine stop switch (page 20-20)
• Loose or poor contact connector
• Open circuit in wire harness

YES – GO TO STEP 7.

7. Starter Relay Switch Continuity Inspection

Connect the starter relay switch connector.

Turn the ignition switch ON and the engine stop switch " Ⓞ ", check for continuity at the starter relay switch terminals when the starter switch is pushed.

Is there continuity?

NO – Faulty starter relay switch

YES – Loose or poor contact starter relay switch connector

The starter motor turns when the transmission is in neutral, but does not turn with the transmission in any position except neutral, with the side stand up and the clutch lever pulled in.

1. Clutch Switch Inspection

Check the clutch switch operation.

Is the clutch switch operation normal?

NO – Faulty clutch switch

YES – GO TO STEP 2.

2. Side Stand Switch Inspection

Check the side stand switch operation.

Is the side stand switch operation normal?

NO – Faulty side stand switch (page 20-22)

YES – • Open circuit in wire harness
• Loose or poor contact connector

Starter motor turns engine slowly

- Low battery voltage
- Poorly connected battery terminal cable
- Poorly connected starter motor cable
- Faulty starter motor
- Poorly connected battery ground cable

Starter motor turns, but engine does not turn

- Starter motor is running backwards
 - Case assembled improperly
 - Terminals connected improperly
- Faulty starter clutch
- Damaged or faulty starter drive gear, driven gear and/or reduction gear

Starter relay switch "Clicks", but engine does not turn over

- Crankshaft does not turn due to engine problems

ELECTRIC STARTER

STARTER MOTOR

REMOVAL

- With the ignition switch OFF, remove the negative cable at the battery before servicing the starter motor.

Drain the coolant (page 7-6).

Remove the throttle body (page 6-72).

Disconnect the ECT sensor connector and remove the thermostat housing (page 7-9).

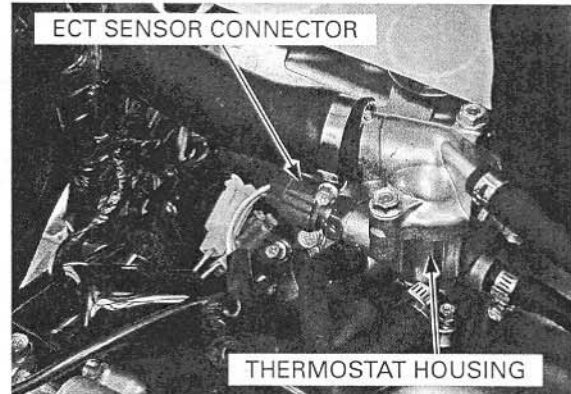

Remove the terminal nut and starter motor cable from the starter motor.

Remove the starter motor mounting bolts and ground cable.

Pull the starter motor out of the crankcase.

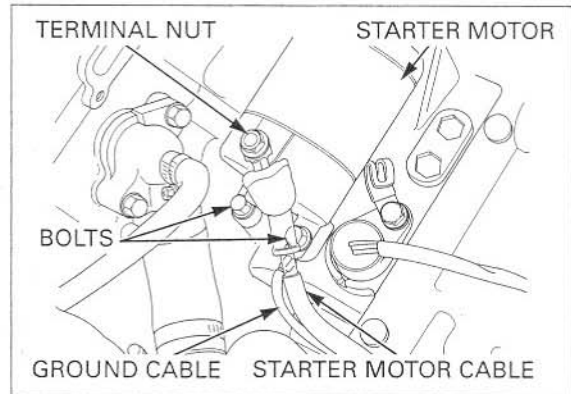

DISASSEMBLY

Remove the following:

- O-ring

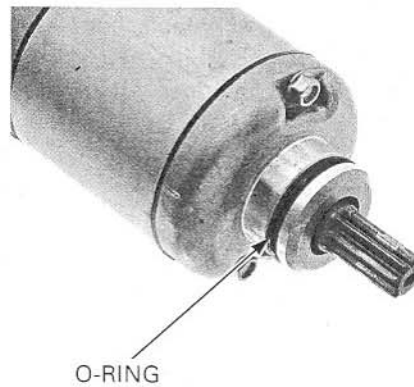

ELECTRIC STARTER

- Starter motor case bolts and O-rings

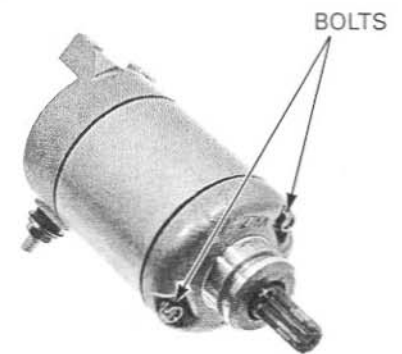

- Record the location and number of shims.*
- Front cover
 - Seal ring
 - Lock washer
 - Insulated washer
 - Shim (s)

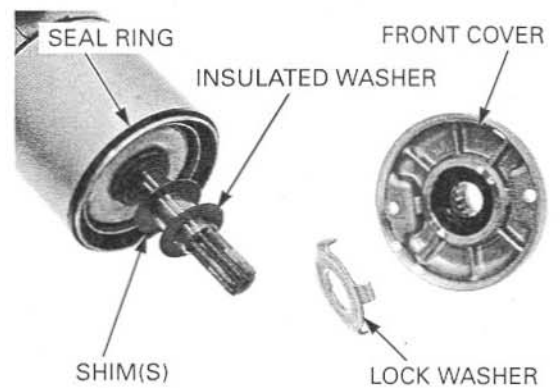

- Record the location and number of shims.*
- Rear cover assembly
 - Seal ring
 - Shim (s)
 - Armature

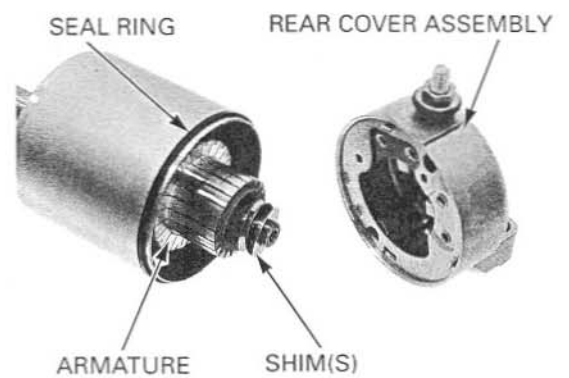

INSPECTION

Check the bushing in the rear cover for wear or damage.



ELECTRIC STARTER

Check the oil seal and needle bearing in the front cover for deterioration, wear or damage.

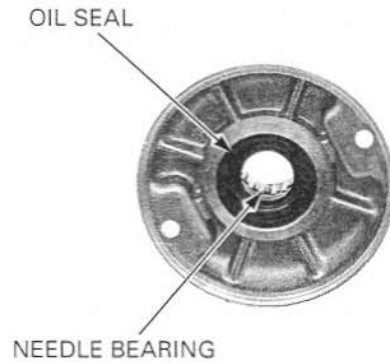

Do not use emery or sand paper on the commutator.

Check the commutator bars of the armature for discoloration.

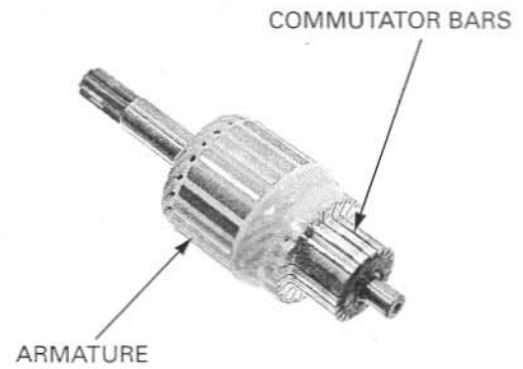

Check for continuity between pairs of commutator bars. There should be continuity.



Check for continuity between each commutator bar and the armature shaft. There should be no continuity.



Check for continuity between the insulated brush and cable terminal.
There should be continuity.

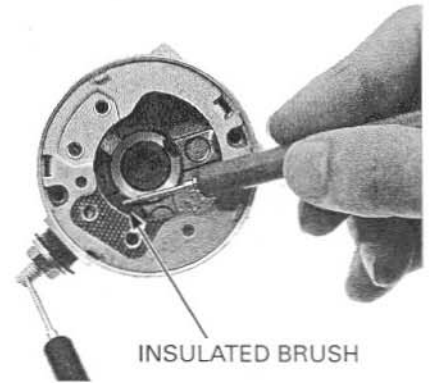

Check for continuity between the cable terminal and the rear cover.
There should be no continuity.

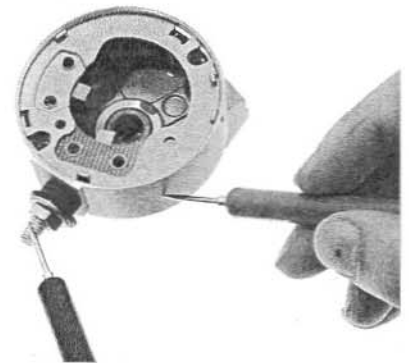

Record the location and number of insulators.

Remove the following:

- Nut
- Washer
- Insulators
- O-ring
- Brush holder assembly
- Brush/terminal

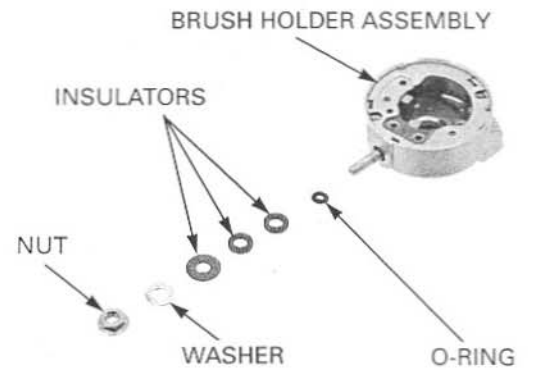

Inspect the brushes for damage and measure the brush length.

SERVICE LIMIT: 6.5 mm (0.26 in)



ELECTRIC STARTER

ASSEMBLY

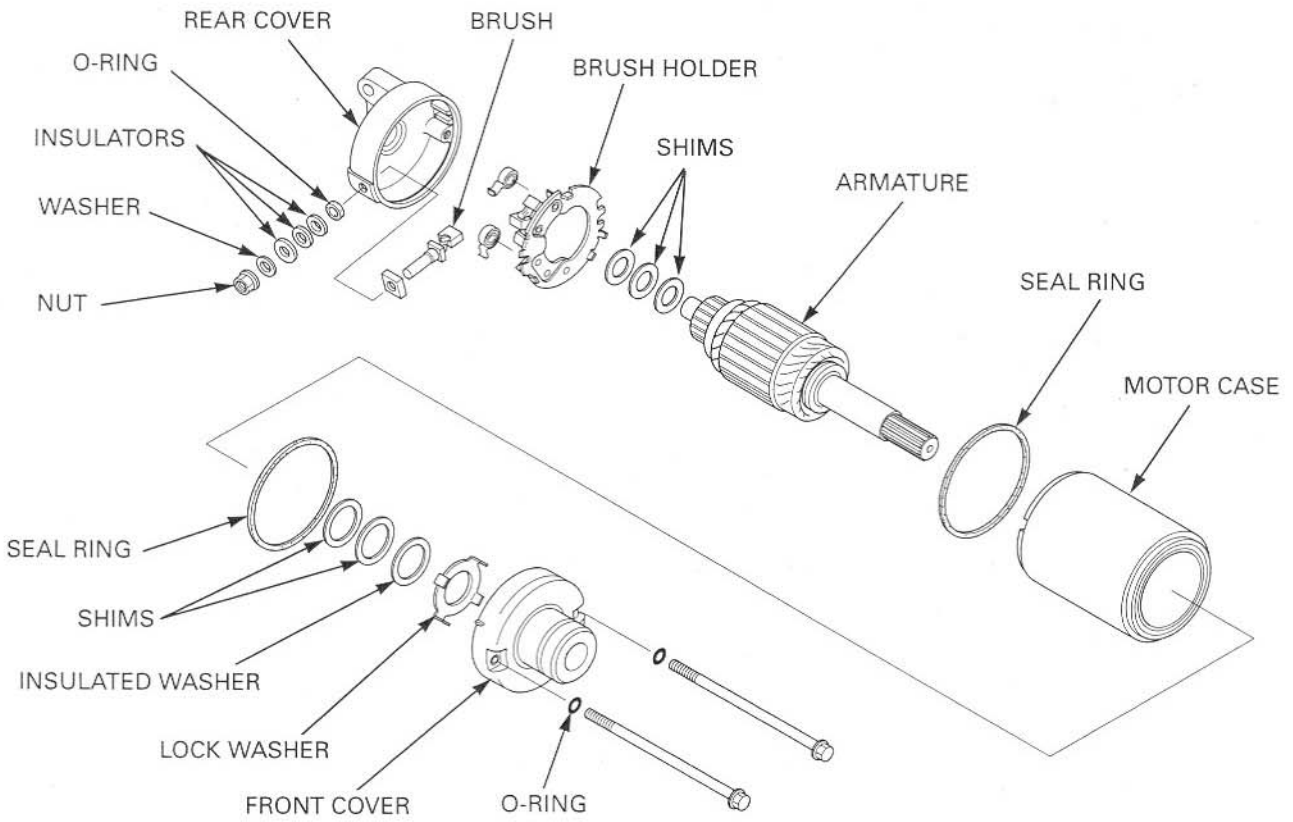

Install the brushes into the brush holder.
Install the cable terminal and brush holder into the rear cover, aligning the holder tab with the rear cover groove.

Install the insulators properly as noted during removal.

Install the following:

- New O-ring
- Insulators
- Washer
- Nut

ALIGN

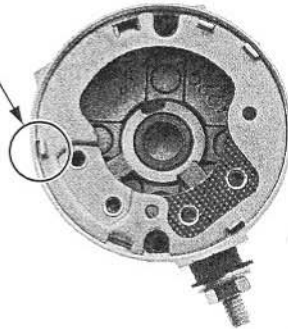

Install the armature in the motor case.
When installing the armature into the motor case, hold the armature tightly to keep the magnet of the case from pulling the armature against it.

NOTICE

The coil may be damaged if the magnet pulls the armature against the case.

ARMATURE

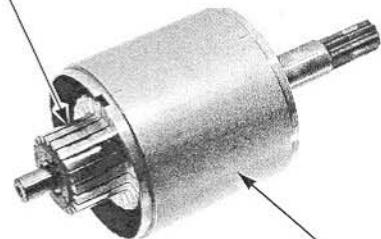

MOTOR CASE

ELECTRIC STARTER

Install the shims properly as noted during removal.

Install a new seal ring onto the motor case.
Install the shim(s) onto the armature shaft.
Apply thin coat of grease to the armature shaft end.

Install the rear cover assembly, while pushing in the brushes into the brush holder and aligning the brush holder tab with the motor case groove.

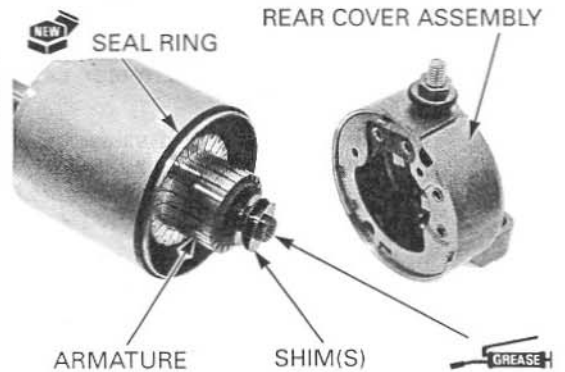

Install the shims properly as noted during removal.

Install the shim(s) and insulated washer onto the armature shaft.
Install a new seal ring onto the motor case.
Apply grease to the oil seal lip and needle bearing in the front cover.

Install the lock washer onto the front cover.
Install the front cover.

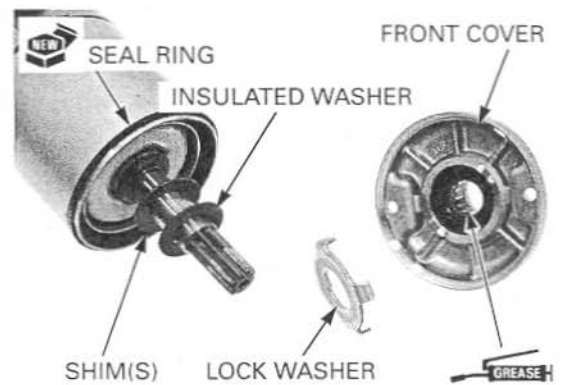

Make sure the index lines are aligned.
Install the new O-rings onto the motor case bolts.
Install and tighten the case bolts securely.

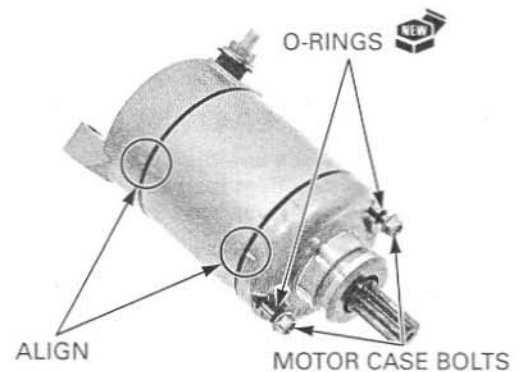

Coat a new O-ring with oil and install it into the starter motor groove.



ELECTRIC STARTER

INSTALLATION

Install the starter motor into the crankcase.

Route the starter motor cable and ground cable properly.

Install the ground cable and mounting bolts, and tighten the bolts securely.

Install the starter motor cable, then tighten the terminal nut to the specified torque.

TORQUE: 12 N·m (1.2 kgf·m, 9 lbf·ft)

Install the rubber cap securely.

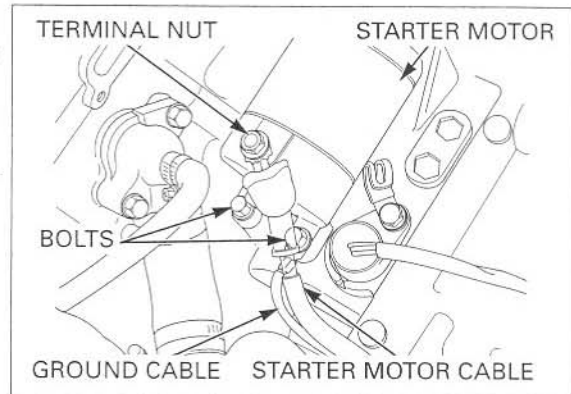

Install the following:

- Thermostat housing (page 7-9)
- Throttle body (page 6-77)

Fill the cooling system with the recommended coolant (page 7-6).

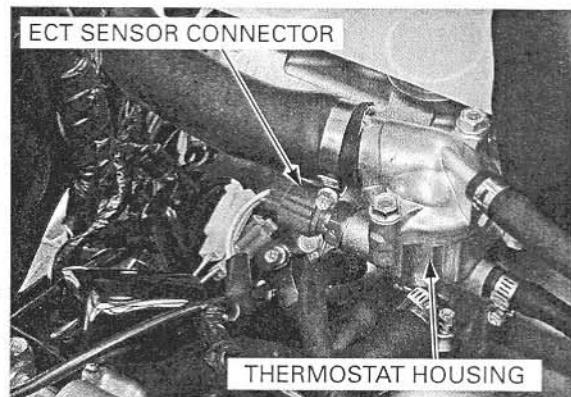

STARTER RELAY SWITCH

OPERATION INSPECTION

Remove the following:

- Seat (page 3-4).
- Rear cowl (page 3-5).

Shift the transmission into neutral.

Turn the ignition switch ON and engine stop switch "Q".

Press the starter switch button.

The coil is normal if the starter relay switch "clicks".

If you don't hear the switch "click", inspect the relay switch using the procedure below.

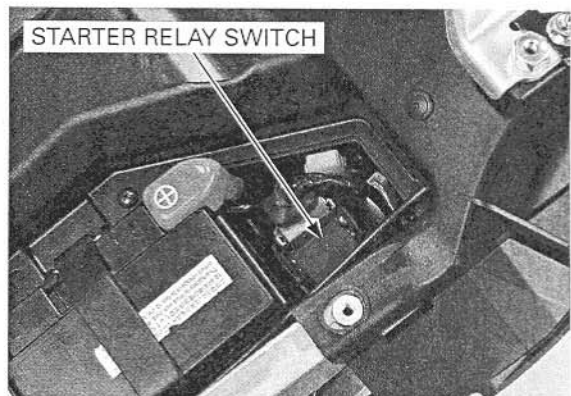

GROUND LINE INSPECTION

Disconnect the starter relay switch 4P (Red) connector.

Check for continuity between the Green/red wire (ground line) and ground.

If there is continuity when the transmission is in neutral and clutch lever released or when the clutch lever pulled and the side stand up, the ground circuit is normal (In neutral, there is a slight resistance due to the diode).

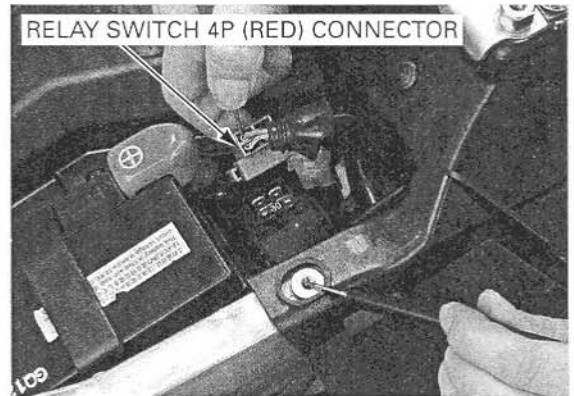

RELAY SWITCH 4P (RED) CONNECTOR

STARTER RELAY VOLTAGE INSPECTION

Connect the starter relay switch 4P (Red) connector.

Shift the transmission into neutral.

Measure the voltage between the Yellow/red wire terminal (+) and ground (-).

If the battery voltage appears only when the starter switch is pushed with the ignition switch ON and engine stop switch "Q", it is normal.

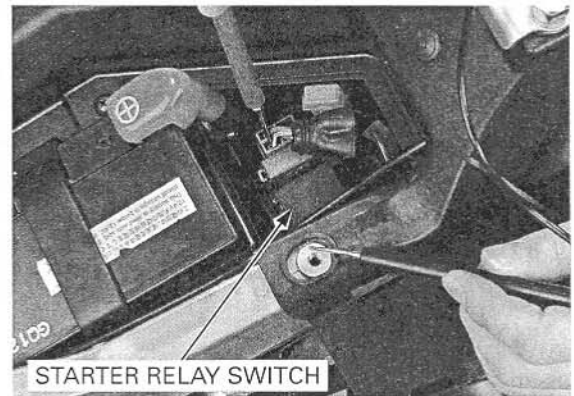

STARTER RELAY SWITCH

CONTINUITY INSPECTION

Connect an ohmmeter to the starter relay switch large terminals.

Turn the ignition switch ON and the engine stop switch "Q".

Check for continuity between the starter relay switch terminals when the starter switch is pushed.

There should be continuity when the starter switch is pushed.

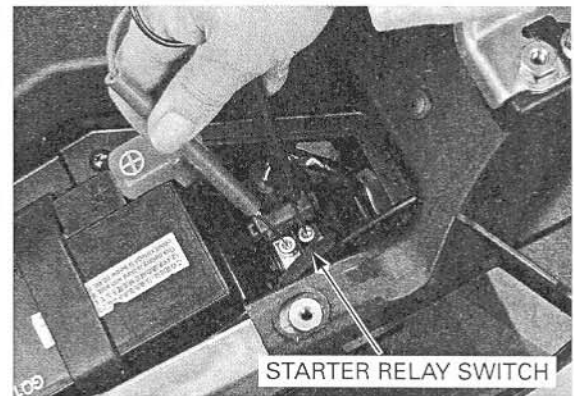

STARTER RELAY SWITCH

ELECTRIC STARTER

DIODE

REMOVAL

Remove the following:

- Lower cowls (page 3-6)
- Middle cowls (page 3-7)

Open the fuse box and remove the diode.

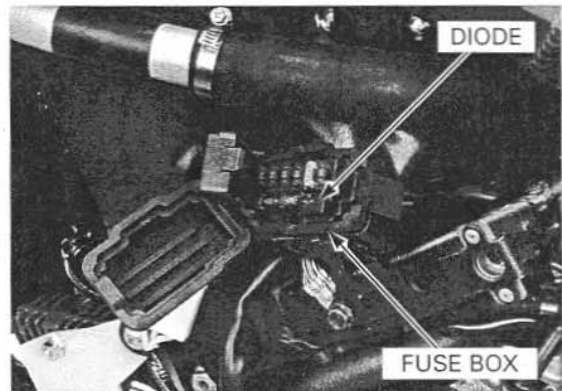

INSPECTION

Check for continuity between the diode terminals. When there is continuity, a small resistance value will register.

If there is continuity, in one direction, the diode is normal.

INSTALLATION

Install the diode in the reverse order of removal.

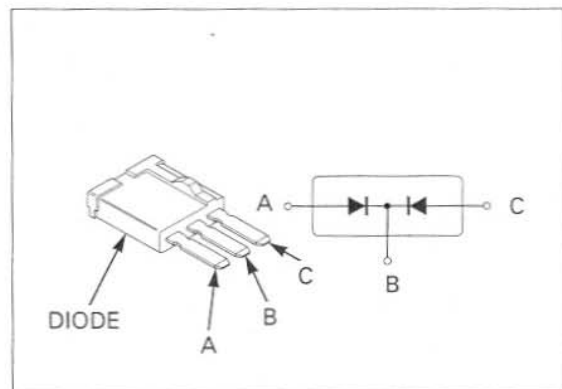

20. LIGHTS/METERS/SWITCHES

SYSTEM LOCATION.....	20-2	ECT SENSOR	20-16
SERVICE INFORMATION	20-3	OIL PRESSURE SWITCH	20-16
TROUBLESHOOTING	20-5	FUEL LEVEL SENSOR	20-18
HEADLIGHT.....	20-6	IGNITION SWITCH	20-19
POSITION LIGHT	20-7	HANDLEBAR SWITCHES	20-20
TURN SIGNAL	20-8	BRAKE LIGHT SWITCH	20-21
BRAKE/TAIL LIGHT	20-9	CLUTCH SWITCH	20-21
LICENCE LIGHT.....	20-10	NEUTRAL SWITCH.....	20-22
COMBINATION METER.....	20-11	SIDE STAND SWITCH	20-22
SPEEDOMETER/VEHICLE SPEED SENSOR (VSS)	20-13	HORN	20-24
TACHOMETER	20-14	TURN SIGNAL RELAY.....	20-24
		HEADLIGHT RELAY.....	20-25

LIGHTS/METERS/SWITCHES
SYSTEM LOCATION

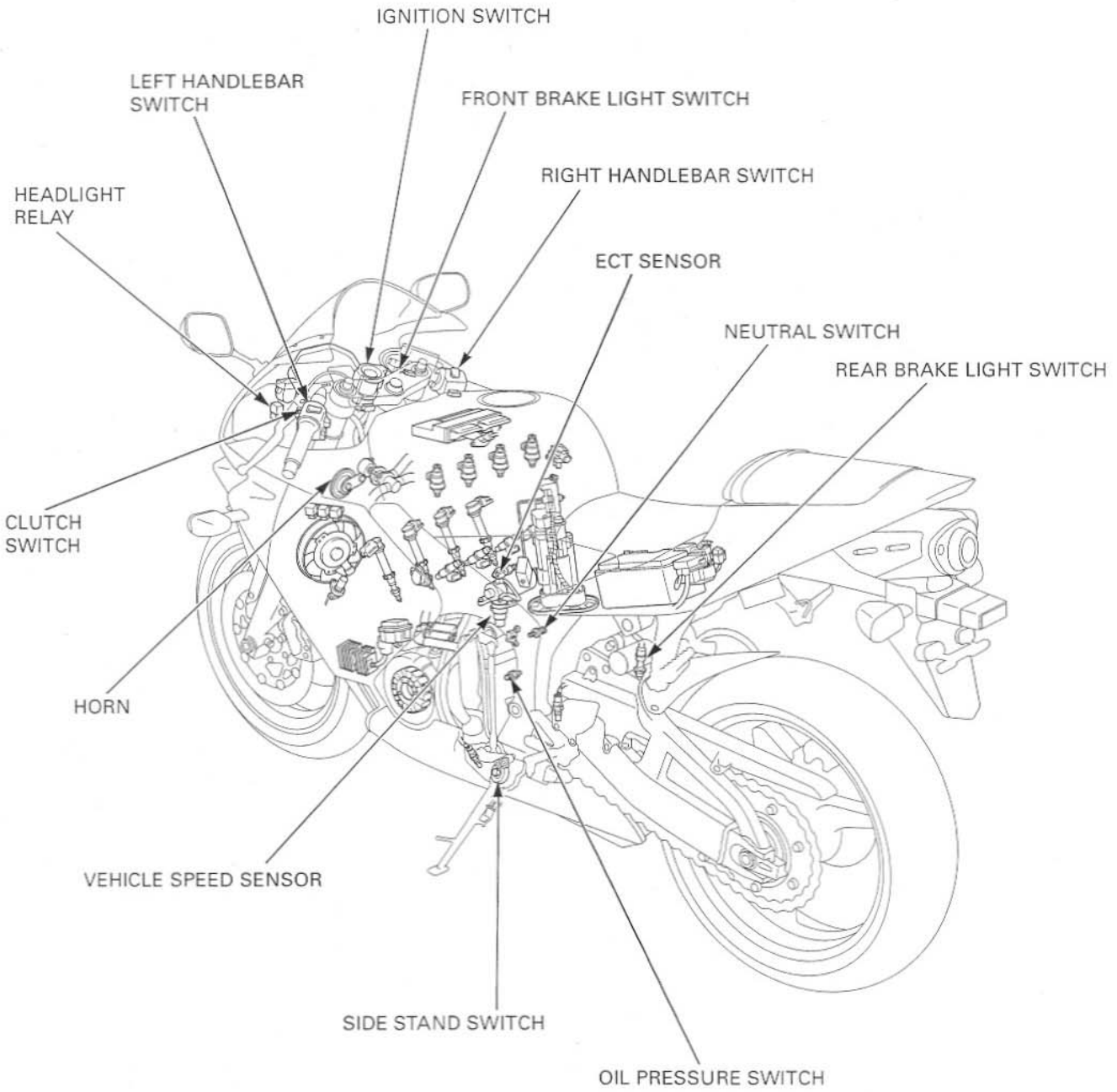

20. LIGHTS/METERS/SWITCHES

SYSTEM LOCATION.....	20-2	ECT SENSOR	20-16
SERVICE INFORMATION	20-3	OIL PRESSURE SWITCH	20-16
TROUBLESHOOTING	20-5	FUEL LEVEL SENSOR	20-18
HEADLIGHT.....	20-6	IGNITION SWITCH	20-19
POSITION LIGHT	20-7	HANDLEBAR SWITCHES	20-20
TURN SIGNAL	20-8	BRAKE LIGHT SWITCH	20-21
BRAKE/TAIL LIGHT	20-9	CLUTCH SWITCH	20-21
LICENCE LIGHT.....	20-10	NEUTRAL SWITCH.....	20-22
COMBINATION METER.....	20-11	SIDE STAND SWITCH	20-22
SPEEDOMETER/VEHICLE SPEED SENSOR (VSS)	20-13	HORN	20-24
TACHOMETER	20-14	TURN SIGNAL RELAY.....	20-24
		HEADLIGHT RELAY.....	20-25

LIGHTS/METERS/SWITCHES
SYSTEM LOCATION

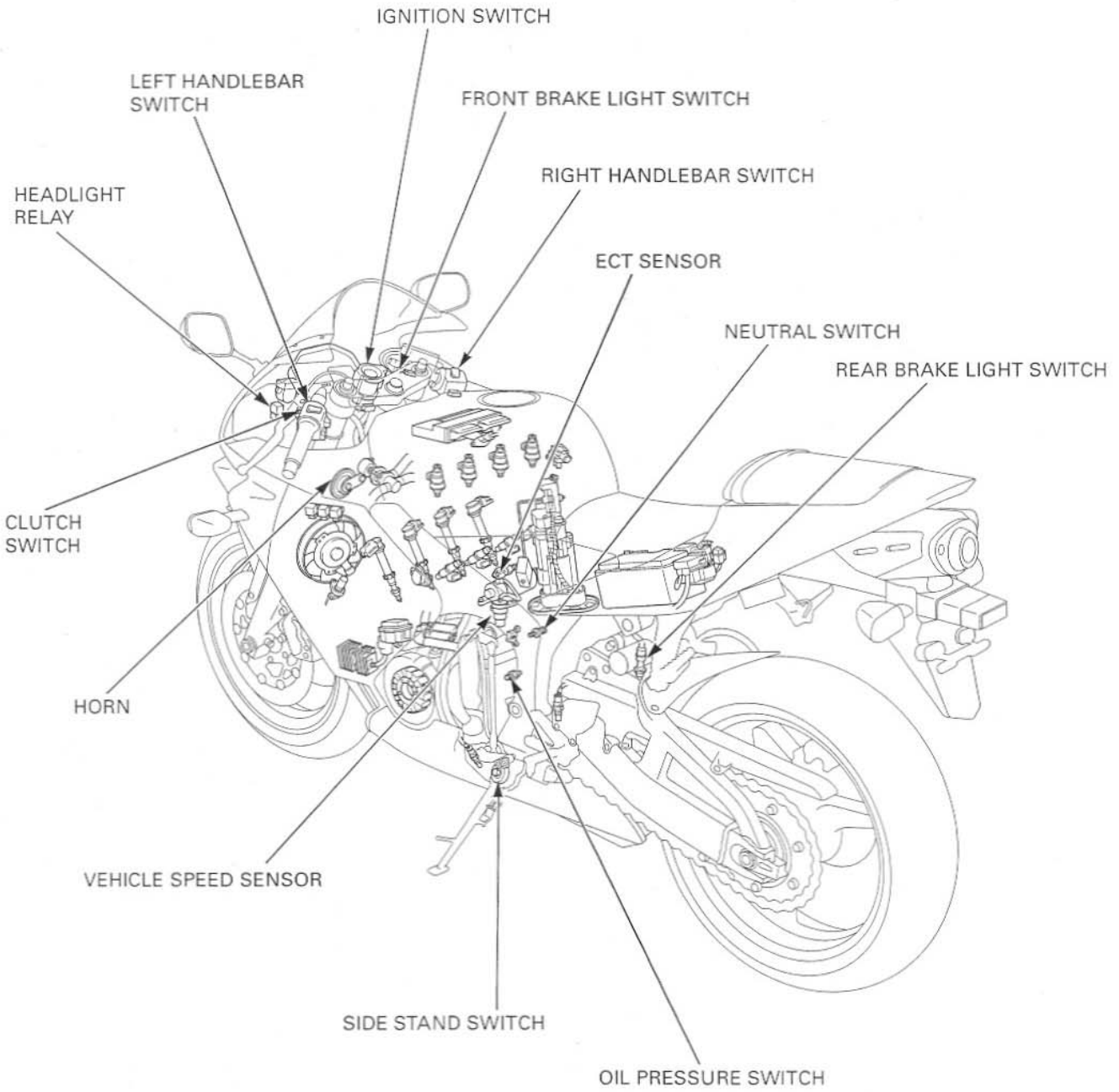

SERVICE INFORMATION

GENERAL

NOTICE

- A halogen headlight bulb becomes very hot while the headlight is ON, and remain hot for a while after it is turned OFF. Be sure to let it cool down before servicing.
- Note the following when replacing the halogen headlight bulb.
 - Wear clean gloves while replacing the bulb. Do not put finger prints on the headlight bulb, as they may create hot spots on the bulb and cause it to fail.
 - If you touch the bulb with your bare hands, clean it with a cloth moistened with denatured alcohol to prevent its early failure.
 - Be sure to install the dust cover after replacing the bulb.
- Use an electric heating element to heat the water/coolant mixture for the ECT sensor inspection. Keep flammable materials away from the electric heating element. Wear protective clothing, insulated gloves and eye protection.
- Check the battery condition before performing any inspection that requires proper battery voltage.
- A continuity test can be made with the switches installed on the motorcycle.
- The following color codes are used throughout this section.

Bu = Blue	G = Green	Lg = Light Green	R = Red
Bl = Black	Gr = Gray	O = Orange	W = White
Br = Brown	Lb = Light Blue	P = Pink	Y = Yellow

SPECIFICATIONS

ITEM		SPECIFICATIONS	
Bulbs	Headlight	Hi	12V – 55 W
		Lo	12V – 55 W
	Position light	12V – 5 W	
	Brake/tail light	LED	
	Turn signal light	12V – 21 W X 4	
	Instrument light	LED	
	Turn signal indicator	LED	
	High beam indicator	LED	
	Neutral indicator	LED	
	PGM-FI warning indicator	LED	
Fuse	Main fuse	30 A	
	PGM-FI fuse	20 A	
	Sub fuse	10 A X 4, 20 A X 2	
Tachometer peak voltage		10.5 V minimum	
ECT sensor resistance	80 °C (176 °F)	2.1 – 2.6 kΩ	
	120 °C (248 °F)	0.65 – 0.73 kΩ	

TORQUE VALUES

ECT sensor	23 N·m (2.3 kgf·m, 17 lbf·ft)	
Side stand switch bolt	9.8 N·m (1.0 kgf·m, 7 lbf·ft)	ALOC bolt; replace with a new one
Ignition switch mounting bolt	25 N·m (2.5 kgf·m, 18 lbf·ft)	Replace with a new one
Oil pressure switch	12 N·m (1.2 kgf·m, 9 lbf·ft)	Apply sealant to the threads
Oil pressure switch wire terminal screw	2.0 N·m (0.2 kgf·m, 1.4 lbf·ft)	
Neutral switch	12 N·m (1.2 kgf·m, 9 lbf·ft)	

LIGHTS/METERS/SWITCHES

TOOLS

IgnitionMate Peak Voltage tester
MTP07-0286 (U.S.A. only)

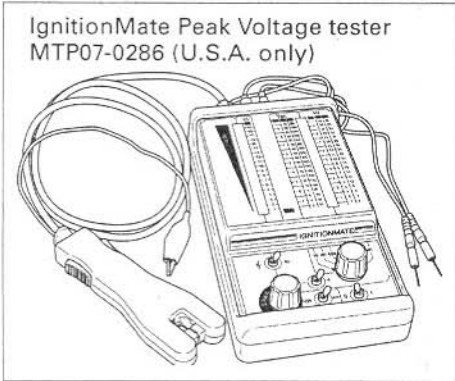

TROUBLESHOOTING

SPEED SENSOR/SPEEDOMETER

The speedometer and odometer/trip meter indicates "----".

Faulty E²-ROM in ECM

The odometer/trip meter operate normally, but the speedometer does not operate
Faulty speedometer in combination meter

The speedometer operate normally, but the odometer/trip meter does not operate
Faulty odometer/trip meter in combination meter

The speedometer operates abnormally

1. Fuse Inspection

Check for blown main fuse or sub fuse.

Is the fuse blown?

YES – Replace the fuse

NO – GO TO STEP 2.

2. Battery Inspection

Make sure the battery is fully charged and in good condition.

Is the battery in good condition?

YES – GO TO STEP 3.

NO – Replace the battery

3. Vehicle Speed Sensor Power Input Voltage Inspection (Speed Sensor Side)

Check for loose or poor contact of the VSS 3P (Natural) connector.

With the ignition switch ON, and measure the voltage at the VSS connector.

Is there Battery Voltage?

NO – • Loose or poor contact of related terminals
• Open circuit in Black or Green wires between the battery and VSS

YES – GO TO STEP 4.

4. Vehicle Speed Sensor Power Input Voltage Inspection (Combination Meter Side)

Check for loose or poor contact of the combination meter multi-connectors.

With the ignition switch ON, and measure the voltage at bottom of the speedometer terminals.

Is there Battery Voltage?

NO – • Loose or poor contact of related terminals
• Open circuit in Black or Green wires between the battery and speedometer

YES – GO TO STEP 5.

5. Vehicle Speed Sensor Signal Line Inspection

With the ignition switch OFF, check for continuity of the Pink wire between the terminals of the VSS and speedometer.

Is there continuity?

NO – Open circuit in Pink wire

YES – GO TO STEP 6.

6. Vehicle Speed Sensor Signal Inspection

Support the motorcycle using a hoist or other support to rise the rear wheel off the ground.

Measure the output voltage (sensor signal) at the speedometer with the ignition switch is ON while slowly turning the rear wheel by your hand.

CONNECTION: Pink (+) – Green (-)

STANDARD: Repeat 0 to 5 V

Is the voltage as specified?

NO – • Faulty VSS
• Loose VSS mounting bolts

YES – Faulty speedometer

HEADLIGHT

BULB REPLACEMENT

Disconnect the headlight bulb connector.
Remove the dust cover.

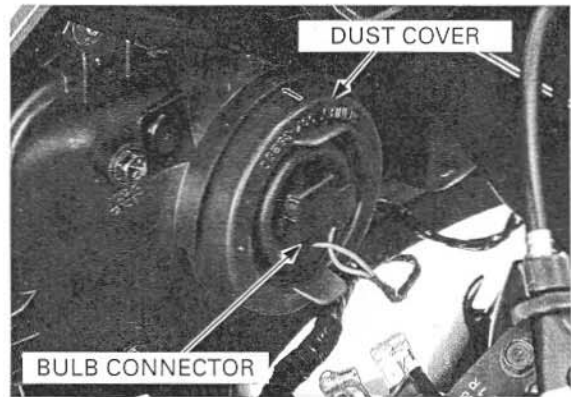

Unhook the bulb retainer and remove the headlight bulb/socket.

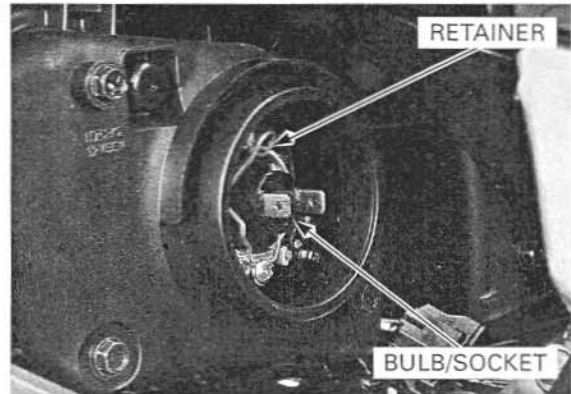

NOTICE

Avoid touching the halogen headlight bulb. Finger prints can create hot spots that cause a bulb to break.

Remove the headlight bulb from the socket.

Install a new bulb into the socket.

If you touch the bulb with your bare hands, clean it with a cloth moistened with denatured alcohol to prevent early bulb failure.

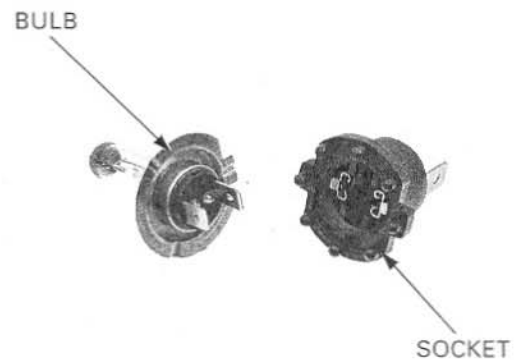

Install the new headlight bulb/socket aligning its tab with the groove in the headlight unit.

Hook the bulb retainer into the headlight unit groove.

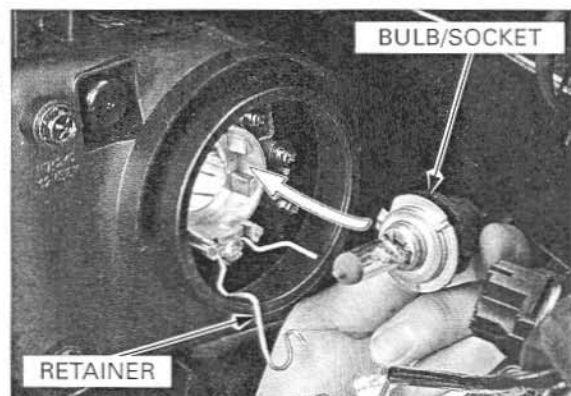

Install the dust cover tightly against the headlight unit with its arrow mark facing up.

Connect the headlight bulb connector.

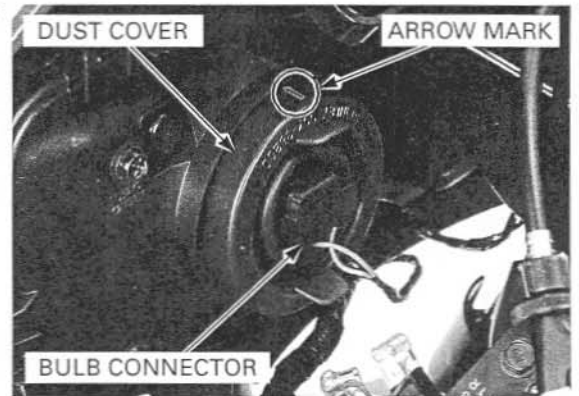

REMOVAL/INSTALLATION

Remove the upper cowl (page 3-9).

Remove the five screws and headlight unit.

Install the headlight unit in the reverse order of removal.

Rout the wire harness properly (page 1-22).

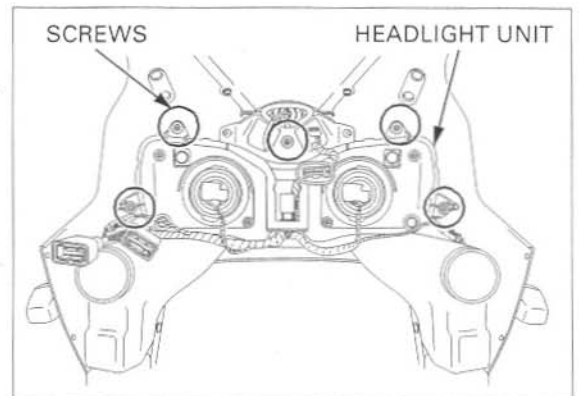

POSITION LIGHT

BULB REPLACEMENT

Remove the screws and position light lens.

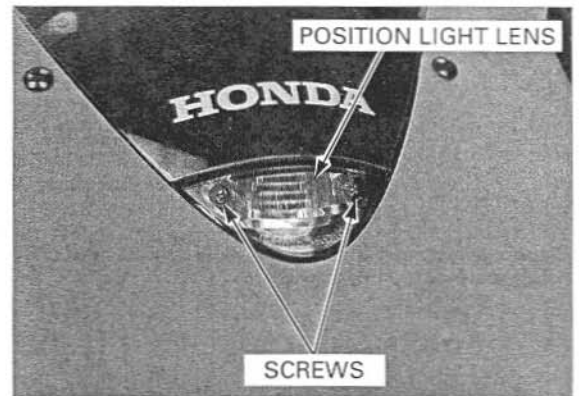

Remove the bulb from the socket, replace it with a new one.

Install the position light lens in the reverse order of removal.

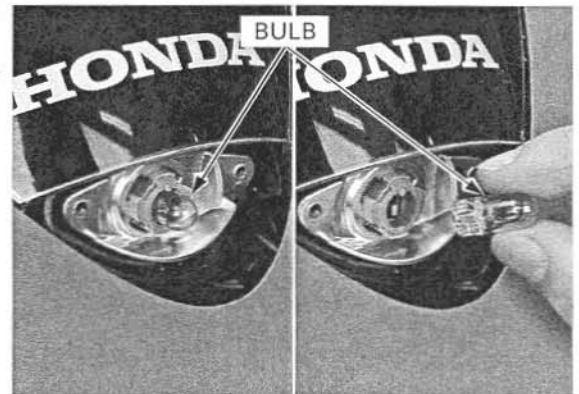

TURN SIGNAL

BULB REPLACEMENT

Remove the screw.

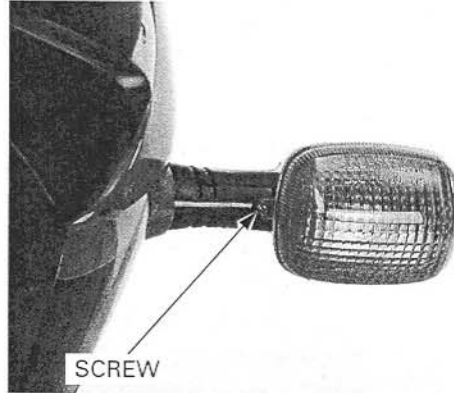

Remove the turn signal lens and seal rubber.

While pushing in, turn the bulb counterclockwise to remove it and replace with a new one.

Install the seal rubber on the lens.

Install the lens by aligning the lens tab with the turn signal unit groove.

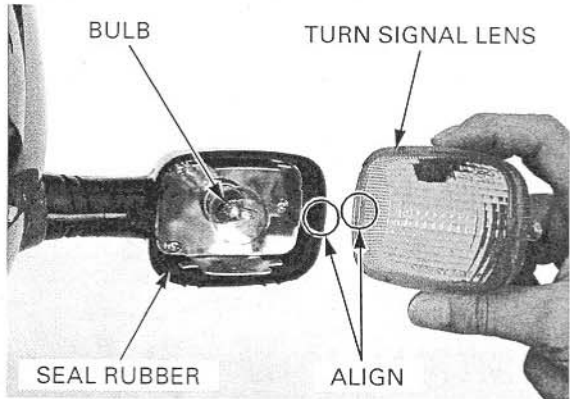

REMOVAL/INSTALLATION

For front turn signal unit removal, see upper cowl disassembly (page 3-11).

For rear turn signal removal, remove the rear fender B (page 3-16).

Remove the screw and guard plates.

Remove the turn signal mounting nut.

Release the turn signal wire and remove the turn signal unit.

Route the turn signal wire properly (page 1-22).

Install the turn signal unit in the reverse order of removal

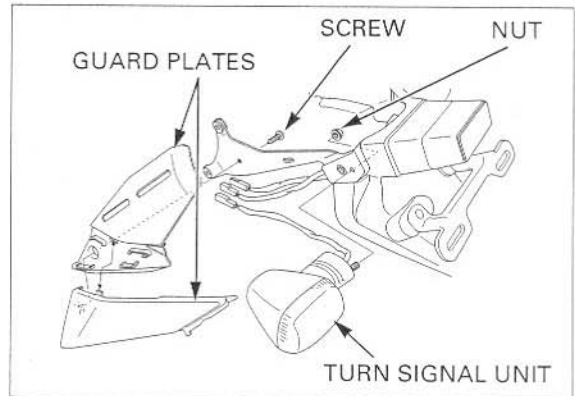

BRAKE/TAIL LIGHT

INSPECTION

Turn the ignition switch ON, and check the tail light operation.

Check that all LED in the brake/tail light unit light illuminate with the front brake lever and/or rear brake pedal applied.

If any LED does not turn on, replace the brake/tail light assembly.

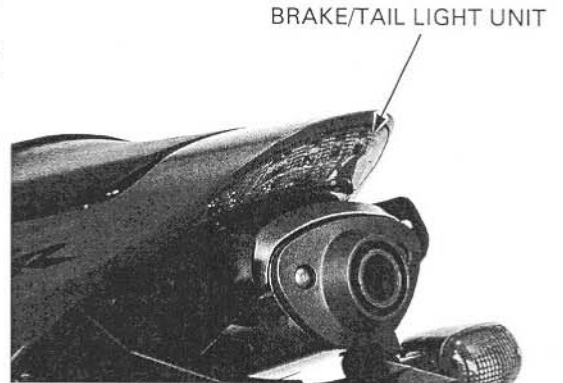

REMOVAL/INSTALLATION

Remove the rear cowl (page 3-5).

Remove the brake/tail light unit mounting screws. Pull out the tabs from the grooves of rear cowl, then remove the brake/tail light unit.

BRAKE/TAIL LIGHT UNIT

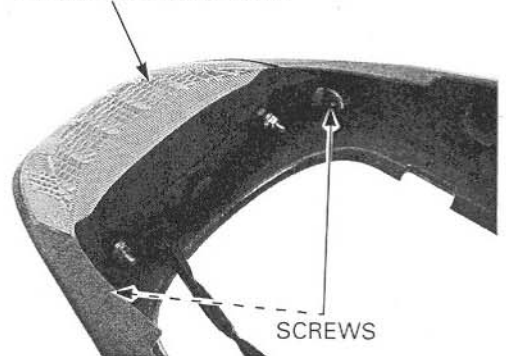

Remove the two nuts, two stays and brake/tail light.

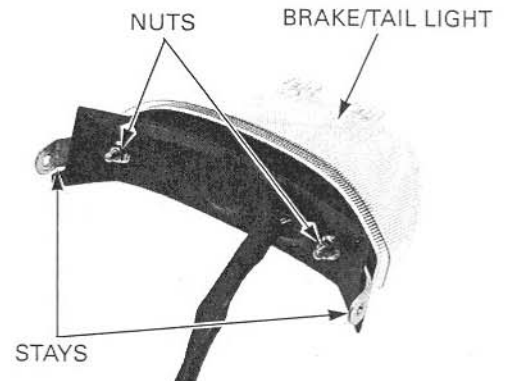

Install the brake/tail light unit onto the rear cowl while aligning the tabs with groove of the rear cowl.

Installation is in the reverse order of removal.

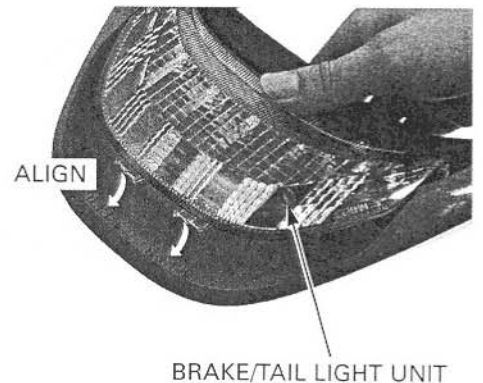

LIGHTS/METERS/SWITCHES

LICENCE LIGHT

REMOVAL/INSTALLATION

Remove the two nuts and wire clamp.

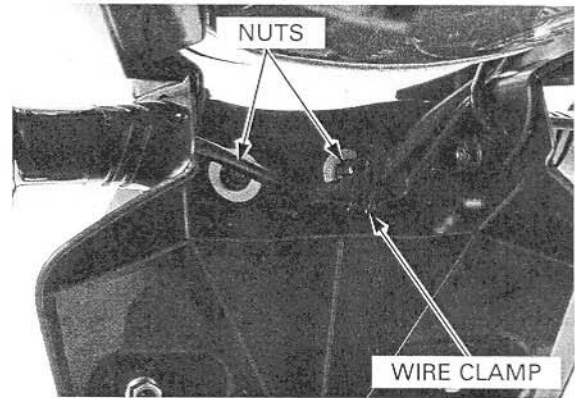

Remove the two screws and joint plates.
Remove the two nuts and lens cover.

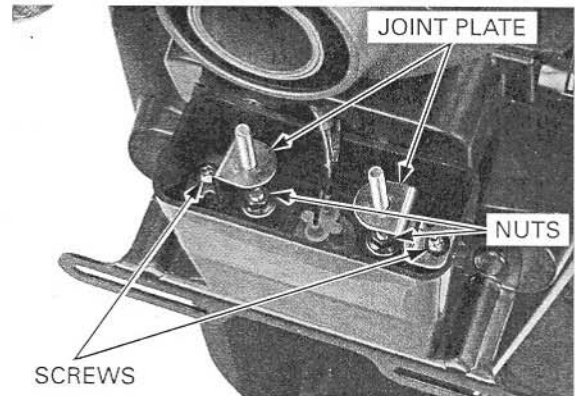

Turn the licence light bulb socket counterclockwise and remove it from the lens cover.

Remove the bulb from the socket, replace it with a new one.

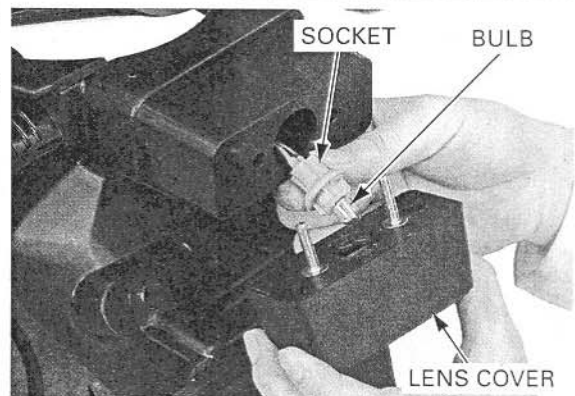

Install the licence light bulb socket in the reverse order of removal.

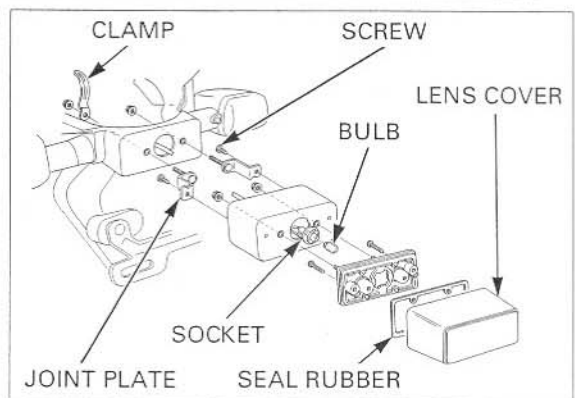

COMBINATION METER

REMOVAL

Remove the upper cowl (page 3-9).

Remove the three screws and combination meter from the bracket.

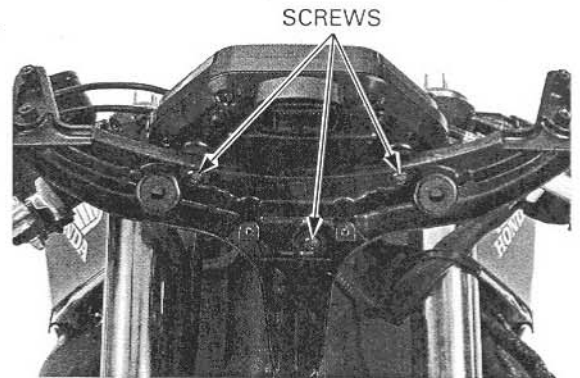

DISASSEMBLY/ASSEMBLY

Remove the screws and separate the front cover from the rear cover.

Remove the set screw that holds the combination meter print board to the rear cover.

COMBINATION METER REAR COVER

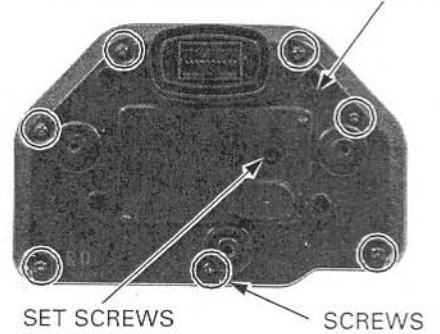

Assemble the combination meter in the reverse order of removal.

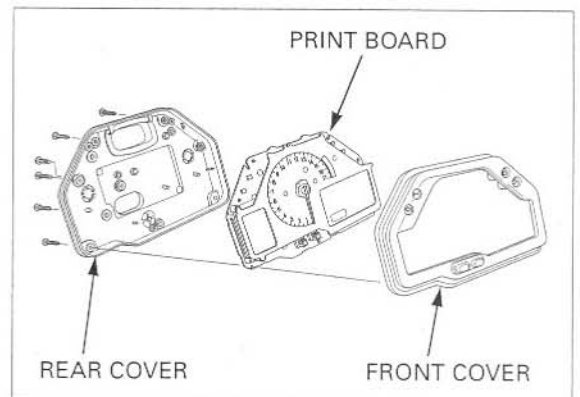

LIGHTS/METERS/SWITCHES

INSTALLATION

Install the combination meter onto the bracket.
Tighten the screws securely.

Install the upper cowl (page 3-12).

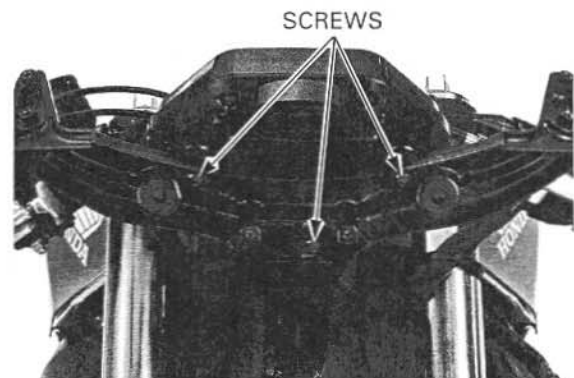

POWER/GROUND LINES INSPECTION

Check the following at the wire harness side connector terminals of the combination meter.

Power input line

Measure the voltage between the Black/brown wire terminal (+) and body ground (-).

There should be battery voltage with the ignition switch ON.

If there is no voltage, check the sub-fuse (10A) and Black/brown wire for a loose connection or an open circuit.

Back-up voltage line

Measure the voltage between the Red/green wire terminal (+) and body ground (-).

There should be battery voltage at all times.

If there is no voltage, check the sub-fuse (10A) and Red/green wire for a loose connection or an open circuit.

Ground line

Measure the continuity between the Green wire terminal (+) and body ground (-).

There should be continuity.

If there is no continuity, check for open circuit in Green wire.

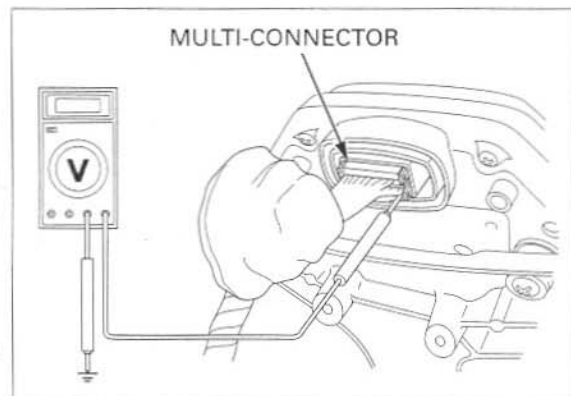

SPEEDOMETER/VEHICLE SPEED SENSOR (VSS)

SYSTEM INSPECTION

Check that the tachometer and coolant temperature meter function properly.

- If they do not function, perform the power and ground line inspection of the combination meter (page 20-12).
- If they function, shift the transmission into neutral, disconnect the combination meter multi-connector and turn the ignition switch ON. Measure the voltage between the Pink/green (+) and Green (-) wire terminals of the wire harness side connector. Slowly turn the rear wheel by hand. There should be 0 to 5 V pulse voltage.
- If pulse voltage appears, replace the combination meter print circuit board.
- If pulse voltage does not appear, check for open or short circuit in Pink/green wire. If the Pink/green wire is OK, check the VSS (page 20-13).

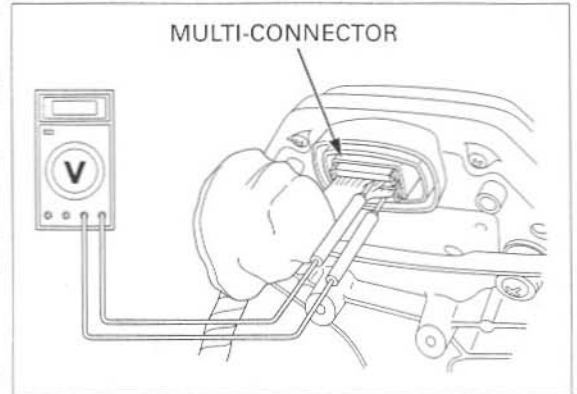

VEHICLE SPEED SENSOR (VSS) INSPECTION

Lift and support the fuel tank (page 6-61).

Disconnect the VSS 3P (Natural) connector and check for loose or poor contact of the connector. Also check for loose or poor contact of the engine sub-harness 12P (Gray) connector (page 1-22).

Turn the ignition switch ON and measure the voltage at the 3P (Natural) connector at the wire harness side.

CONNECTION: Black (+) – Green (-)
STANDARD: Battery voltage

If there is no voltage, check for open circuit in Black and Green wires and loosen contact of the wire harness connectors.

Disconnect the VSS 3P (Natural) connector. Support the motorcycle securely and place the rear wheel off the ground. Shift the transmission into neutral.

Measure the voltage at the sensor connector terminals with the ignition switch ON while slowly turning the rear wheel by hand.

CONNECTION: Pink (+) – Green (-)
STANDARD: Repeat 0 to 5V

If the measurement is out of specification, replace the VSS.

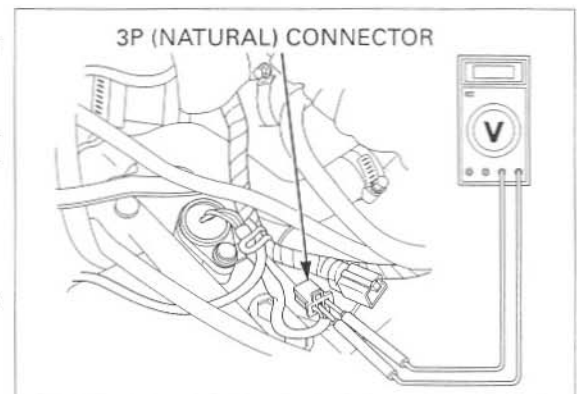
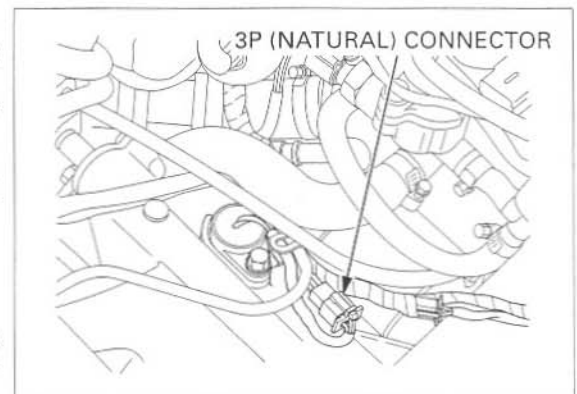

LIGHTS/METERS/SWITCHES

REMOVAL/INSTALLATION

Lift and support the fuel tank (page 6-61).
Disconnect the VSS 3P (Natural) connector.
Remove the bolt, clamp and VSS.

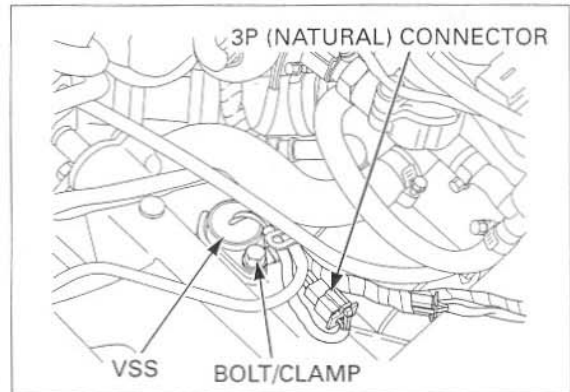

Check the condition of the O-ring, replace it if necessary.
Install the VSS into the upper crankcase.

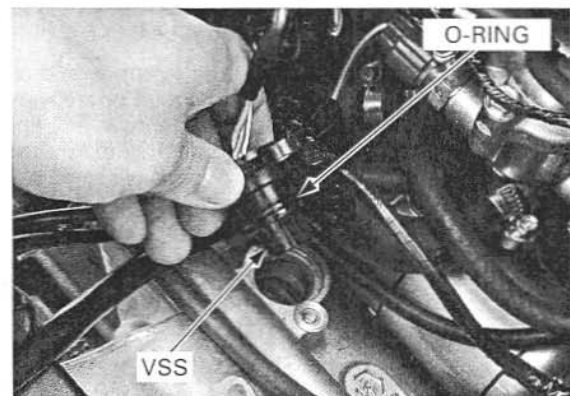

Install and tighten the clamp, bolt securely.
Route the sensor wire properly.
Connect the VSS 3P (Natural) connector.

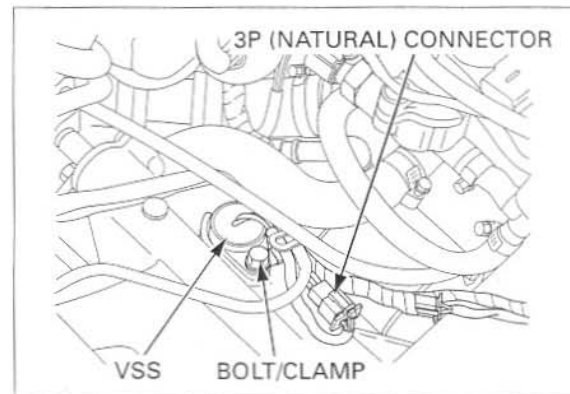

TACHOMETER

SYSTEM INSPECTION

- Check for loose or poor contact terminals at the combination meter multi-connector and sub-harness 12P connectors.

Turn the ignition switch ON, check that the tachometer needle move to full scale and then returns to zero.

If the needle does not show initial function, check the combination meter power input line (page 20-12).

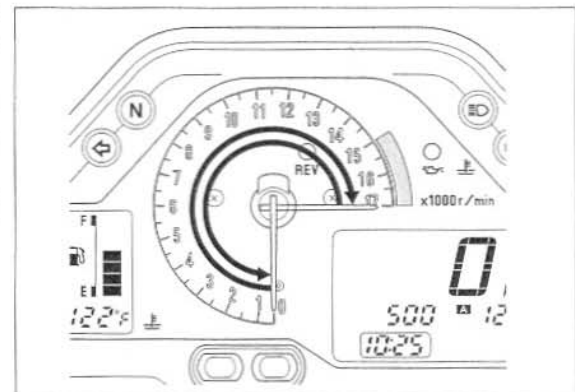

Remove the upper cowl (page 3-9) and expose the combination meter multi-connector.

Connect the peak voltage adaptor to the tachometer Yellow/green terminal and ground.

TOOLS:

IgnitionMate peak voltage tester MTP07-0286 (U.S.A. only) or
Peak voltage adaptor 07HGJ-0020100 (not available in U.S.A.)

with commercially available digital multimeter (impedance 10 M Ω /DCV minimum)

CONNECTION: Yellow/green (+) and Green (-)

Start the engine and measure the tachometer input peak voltage.

PEAK VOLTAGE: 10.5 V minimum

If the peak voltage is normal, replace the combination meter assembly (page 20-11).

If the measured value is below 10.5 V, replace the ECM.

If the value is 0 V, check for continuity between the combination meter multi-connector and ECM 32P (Black) connector Yellow/green terminals.

If there is no continuity, check the wire harness and combination meter sub-harness for an open circuit. If there is continuity, replace the combination meter printed circuit board (page 20-11).

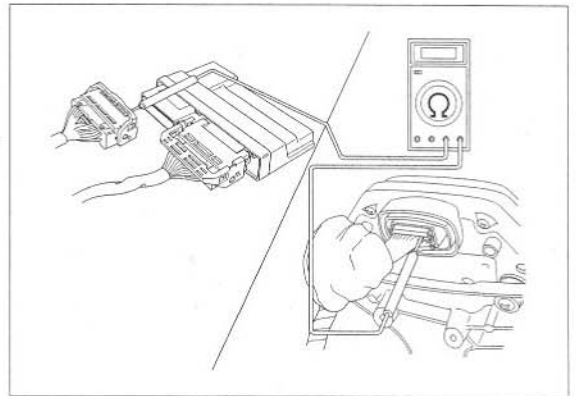
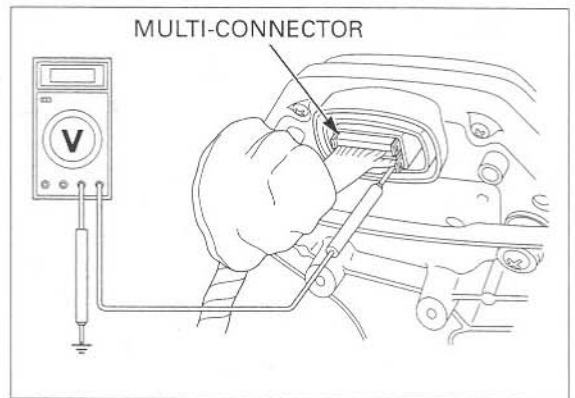

ECT SENSOR

INSPECTION

Remove the ECT sensor (page 6-89).

Suspend the ECT sensor in a pan of coolant (50 – 50 mixture) an electric heating element and measure the resistance through the sensor as the coolant heats up.

- Soak the ECT sensor in coolant up to its threads with at least 40 mm (1.6 in) from the bottom of the pan to the bottom of the sensor.
- Keep the temperature constant for 3 minutes before testing. A sudden change of temperature will result in incorrect readings. Do not let the thermometer or ECT sensor touch the pan.

Replace the sensor if it is out of specification by more than 10% at any temperature listed.

Temperature	80°C (176°F)	120°C (248°F)
Resistance	2.1 – 2.6 kΩ	0.65 – 0.73 kΩ

Install the ECT sensor (page 6-89).

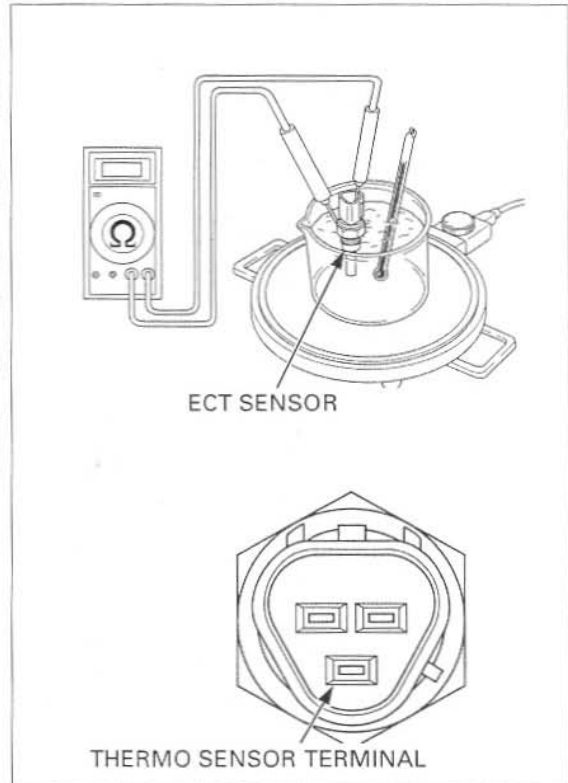

OIL PRESSURE SWITCH

INSPECTION

If the oil pressure warning indicator stays on while the engine is running, check the engine oil level before this inspection.

Make sure that the oil pressure warning indicator comes on with the ignition switch ON.

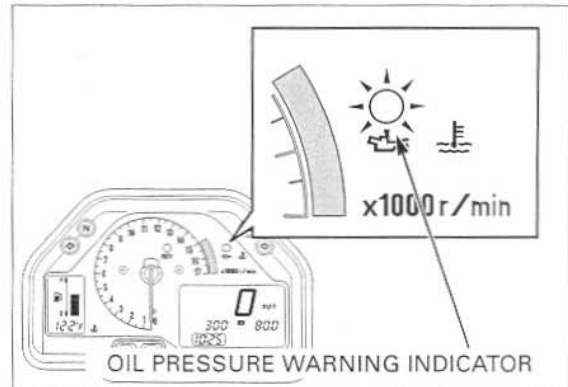

If the indicator does not come on, inspect as follows:

Remove the lower cowls (page 3-6).

Remove the dust cover.

Remove the terminal screw and oil pressure switch wire.

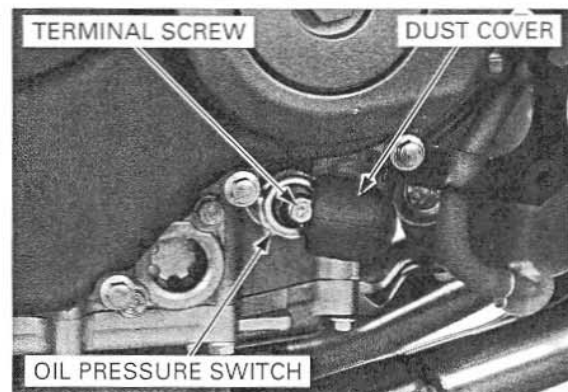

Short the oil pressure switch wire to ground using a jumper wire.

The oil pressure warning indicator comes on when the ignition switch is ON.

If the light does not come on, check the sub-fuse (10A) and wires for a loose connection or an open circuit.

Start the engine and make sure the indicator goes out.

If the indicator does not go out, check the oil pressure (page 5-5).

If the oil pressure is normal, replace the oil pressure switch (page 20-17).

Install the lower cowls (page 3-6).

REMOVAL/INSTALLATION

Remove the lower cowls (page 3-6).

Remove the dust cover, terminal screw and wire. Remove the oil pressure switch while holding switch base.

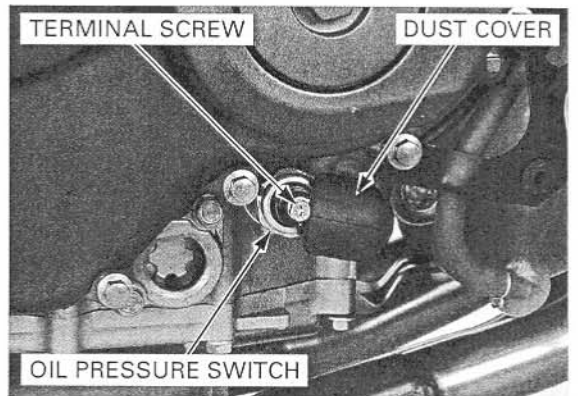
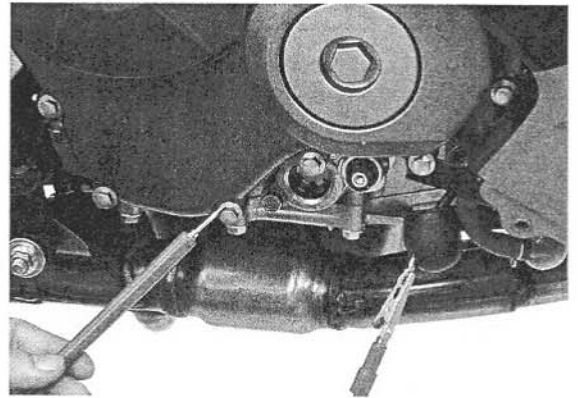

Apply sealant to the oil pressure switch threads as shown.

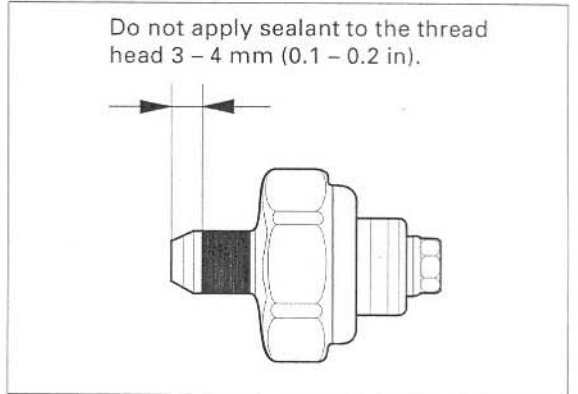

Install the oil pressure switch onto the switch base, tighten the oil pressure switch to the specified torque while holding the switch base.

TORQUE: 12 N·m (1.2 kgf·m, 9 lbf·ft)

Connect the oil pressure switch wire to the switch and tighten the screw to the specified torque.

TORQUE: 2.0 N·m (0.2 kgf·m, 1.4 lbf·ft)

Install the dust cover.

Install the lower cowls (page 3-6).

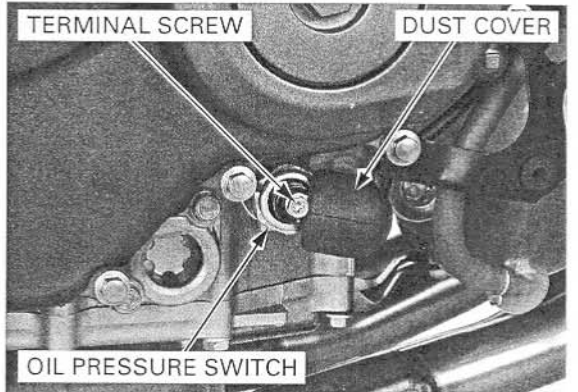

LIGHTS/METERS/SWITCHES

FUEL LEVEL SENSOR

If the fuel meter display is as shown, check for an open circuit in wire harness and the fuel level sensor.

If the wire harness and fuel level sensor are good, replace the combination meter printed circuit board (page 20-11).

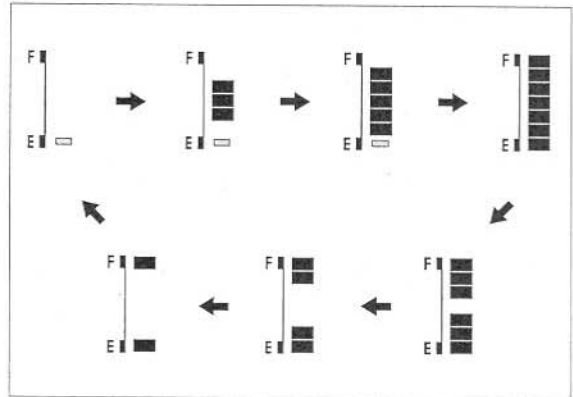

FUEL LEVEL SENSOR INSPECTION

Remove the fuel pump unit (page 6-58).

Connect an ohmmeter to the fuel pump unit 3P (Black) connector Brown/black and Green terminals. Inspect the resistance of the float at the top (full) and bottom (empty) positions.

	TOP (FULL)	BOTTOM (EMPTY)
Resistance	1 – 5 kΩ	92 – 96 kΩ

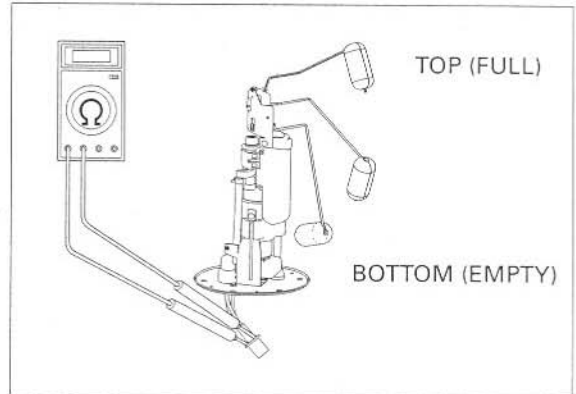

FUEL METER INSPECTION

Connect the fuel pump unit 3P (Black) connector to the wire harness. Turn the ignition switch ON and move the float from bottom (empty) to top (full) to check the fuel meter display indication.

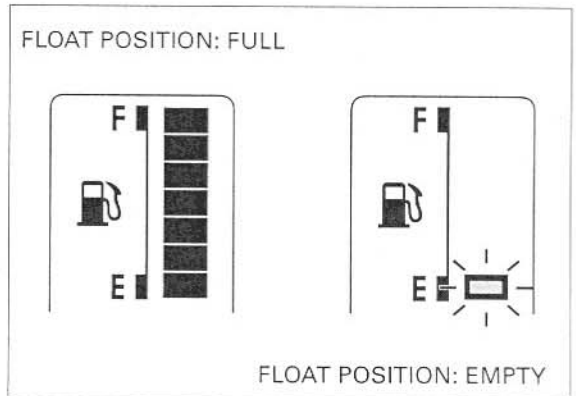

IGNITION SWITCH

INSPECTION

Remove the fuel tank cover (page 3-15).

Disconnect the ignition switch wire 4P (Natural) connector.

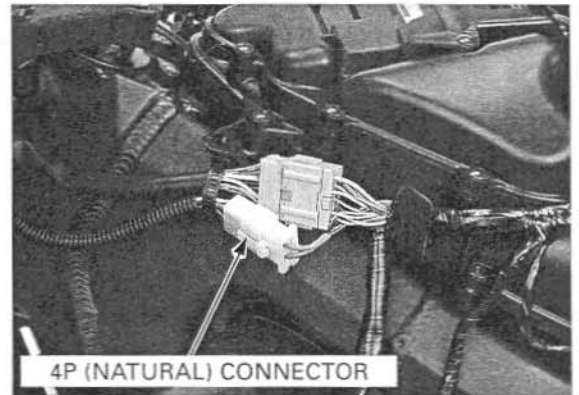

Check for continuity between the wire terminals of the ignition switch connector in each switch position.

Continuity should exist between the color coded wires as follow:

	BAT	IG	IV	KEY
ON	○	○	○	KEY ON
OFF		○	○	KEY OFF
LOCK		○	○	KEY OFF LOCK PIN

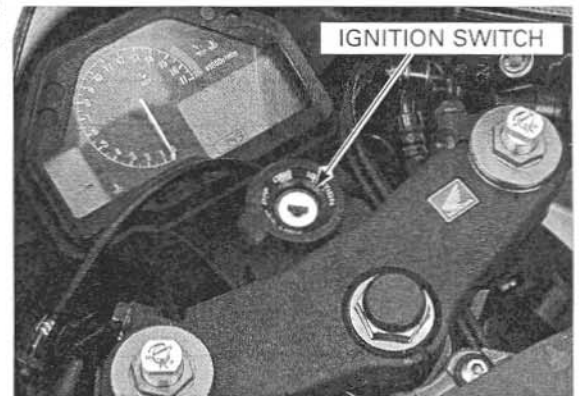

REMOVAL/INSTALLATION

Remove the fuel tank cover (page 3-15).

Remove the upper cowl (page 3-9).

Disconnect the ignition switch wire 4P (Natural) connector.

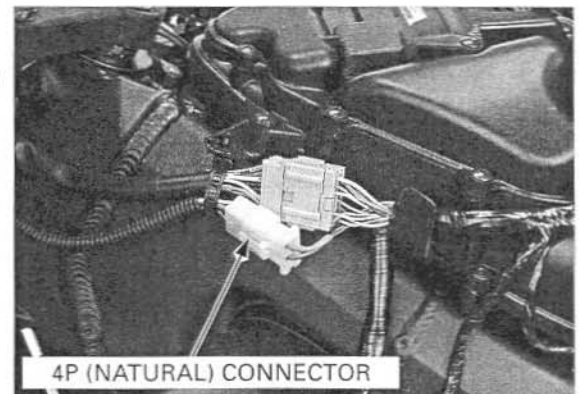

Remove the bolts and ignition switch.

Install the ignition switch to the top bridge. Tighten the new ignition switch mounting bolts to the specified torque.

TORQUE: 25 N·m (2.5 kgf·m, 18 lbf·ft)

Install the removed parts in the reverse order of removal.

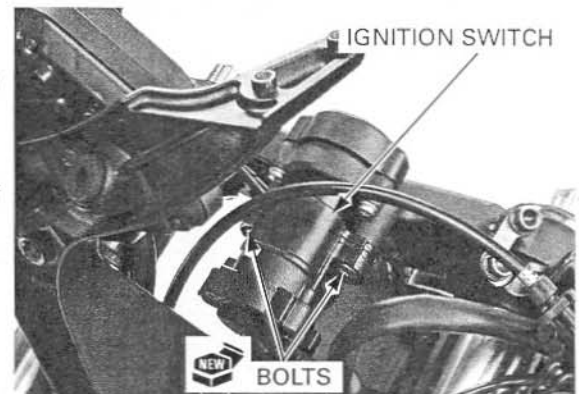

LIGHTS/METERS/SWITCHES

HANDLEBAR SWITCHES

Remove the fuel tank cover (page 3-15).
Disconnect the handlebar switch connectors.

Check for continuity between the wire terminals of the handlebar switch connector.
Continuity should exist between the color coded wire terminals as follows:

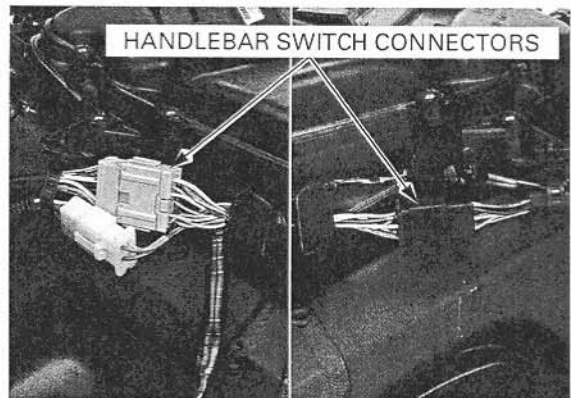

ENGINE STOP SWITCH

	IG	BAT
OFF		
RUN	○—○	
COLOR	BI	W/BI

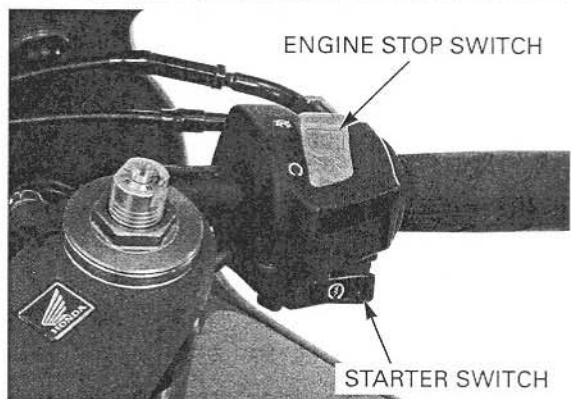

STARTER SWITCH

	ST	IG	BAT3	HL
FREE			○—○	
PUSH	○—○			
COLOR	Y/R	BI	BI/R	Bu/W

TURN SIGNAL SWITCH

	W	R	L	PAT5	PR	PL
R	○—○			○—○		
N				○—○	○—○	○—○
L	○—○		○—○	○—○		
COLOR	Gr	Lb	O	BI/Br	Lb/W	O/W

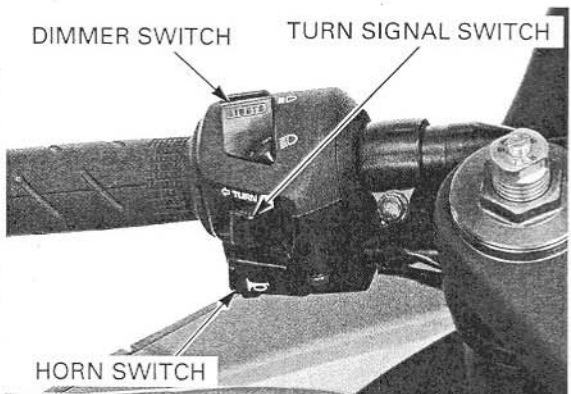

HORN SWITCH

	Ho	BAT
FREE		
PUSH	○—○	
COLOR		Lg

DIMMER SWITCHES

	HL	Lo	Hi
Lo			
(N)	○—○		○—○
Hi	○—○		○—○
COLOR	Bu/W		W

BRAKE LIGHT SWITCH

FRONT

Disconnect the front brake light switch connectors and check for continuity between the terminals.

There should be continuity with the brake lever applied, and there should be no continuity with the brake lever is released.



REAR

Disconnect the rear brake light switch 2P (Black) connector.

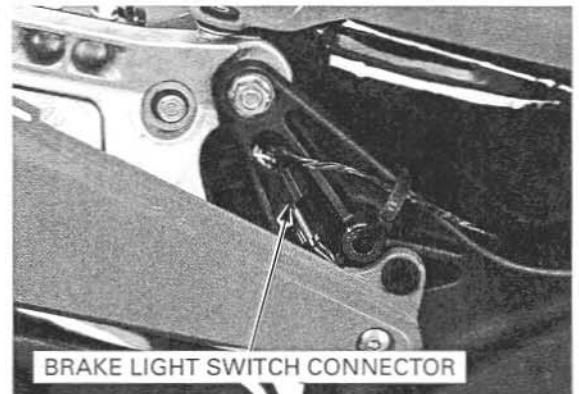

Check for continuity between the terminals.

There should be continuity with the brake pedal applied, and there should be no continuity with the brake pedal is released.

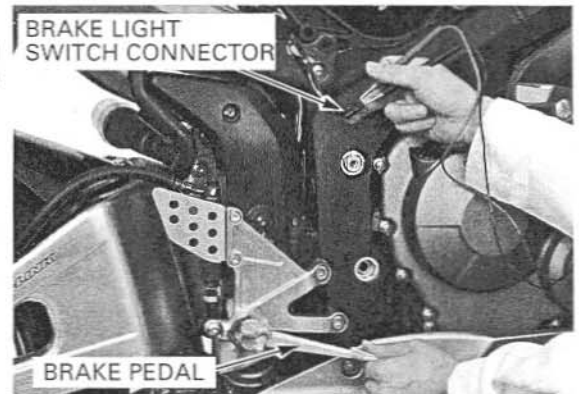

CLUTCH SWITCH

Disconnect the clutch switch connectors.

There should be continuity with the clutch lever applied, and there should be no continuity with the clutch lever is released.

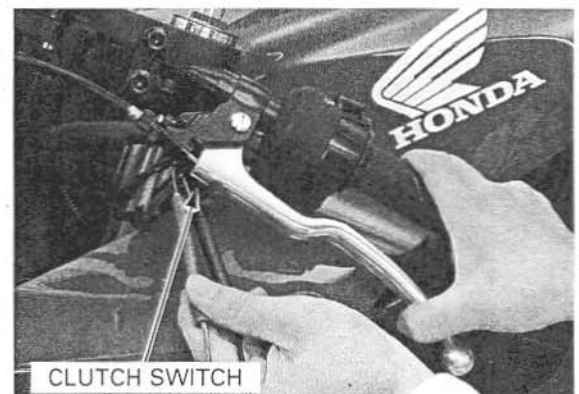

LIGHTS/METERS/SWITCHES

NEUTRAL SWITCH

Disconnect the neutral switch connector from the switch.

Shift the transmission into neutral and check for continuity between the Light green wire and ground.

There should be continuity with the transmission in neutral, and no continuity when the transmission is in gear.

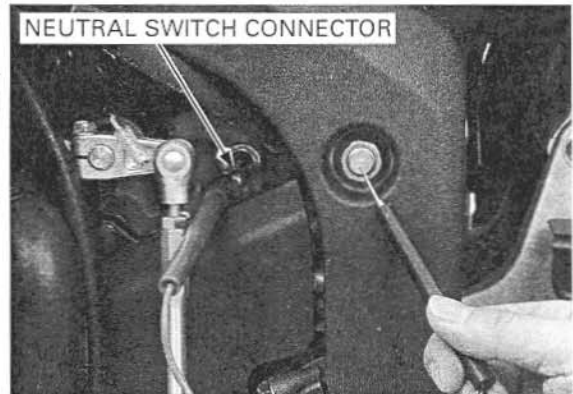

SIDE STAND SWITCH

INSPECTION

Disconnect the side stand switch 2P (Green) connector.

Check for continuity between the wire terminals of the side stand switch 2P (Green) connector. Continuity should exist only when the side stand is up.

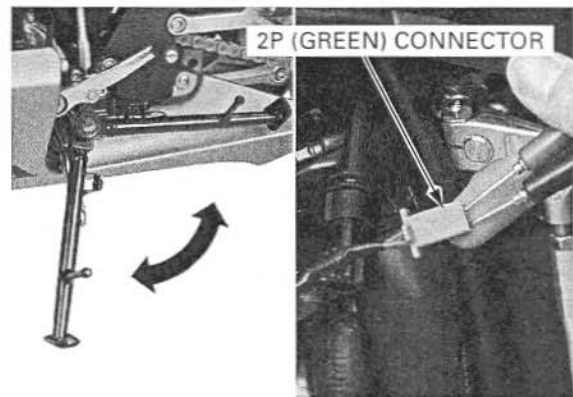
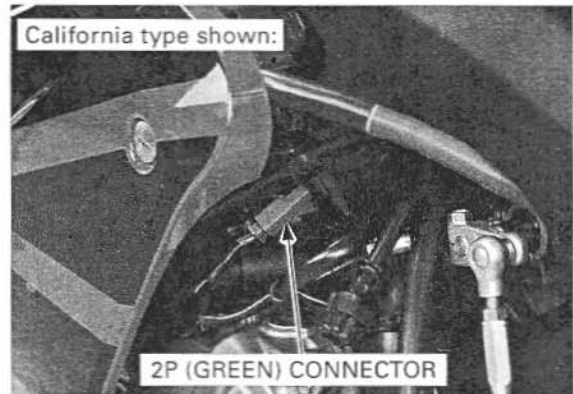

REMOVAL

Disconnect the side stand switch 2P (Green) connector.

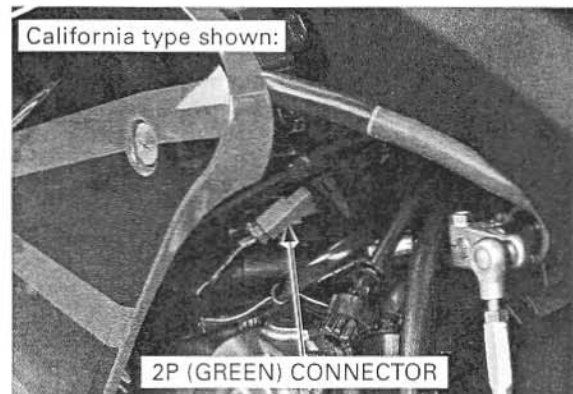

Remove the bolt and side stand switch.

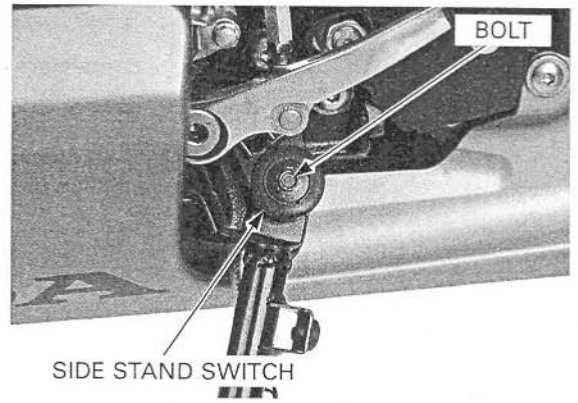

INSTALLATION

Install the side stand switch by aligning the switch pin with the side stand hole and switch groove with the return spring holding pin.

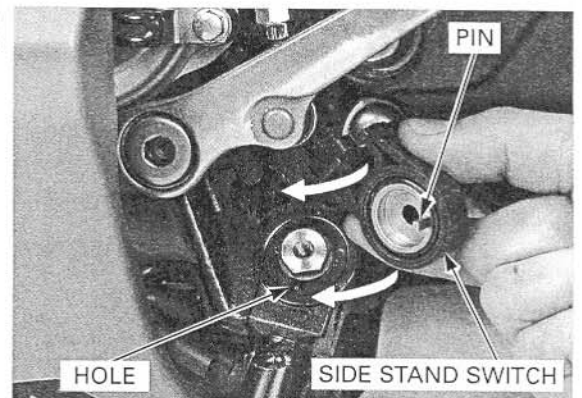

Secure the side stand switch with a new bolt.

TORQUE: 9.8 N-m (1.0 kgf-m, 7 lbf-ft)

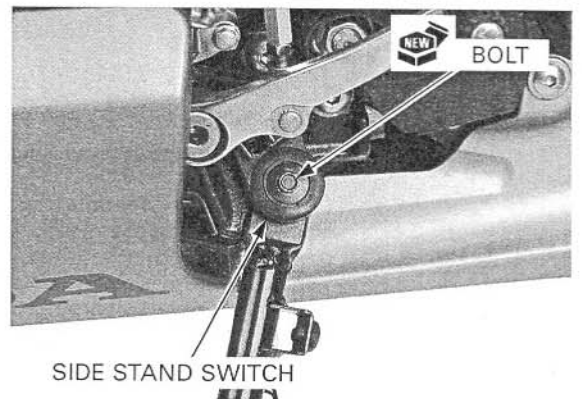

Connect the side stand switch 2P (Green) connector.

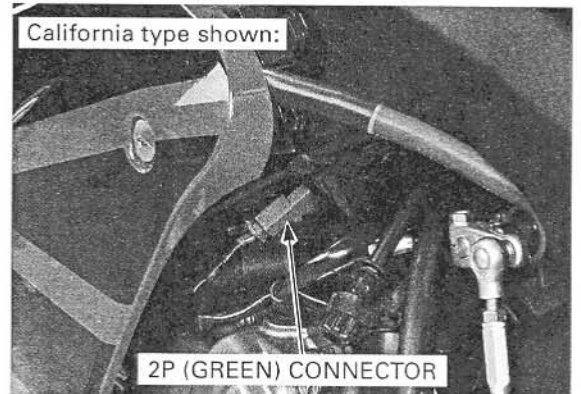

LIGHTS/METERS/SWITCHES

HORN

Disconnect the wire connectors from the horn.

Connect the 12V battery to the horn terminal directly.

The horn is normal if it sounds when the 12 V battery is connected across the horn terminals.

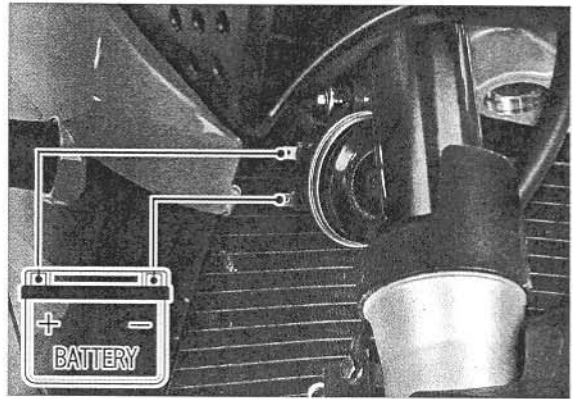

TURN SIGNAL RELAY

INSPECTION

1. Related Circuit Inspection

Check the following

- Burned bulb or non-specified wattage
- Blown fuse
- Ignition switch and turn signal switch function
- Loose connector

Check for the above items.

Are the above items in good condition?

NO - Replace or repair the malfunction part(s)

YES - GO TO STEP 2.

2. Turn Signal Circuit Inspection

Remove the upper cowl (page 3-9).

Connect the combination meter multi-connector. Short the White/green and Gray terminals of the combination multi-connector with a jumper wire. Turn the ignition switch ON and check the turn signal light by turning the turn signal switch on.

Does the light come on?

YES -

- Faulty turn signal relay; replace the combination meter print board (page 20-11)
- Poor connection of the combination meter multi-connector.

NO - Open circuit in White/green or Gray wires.

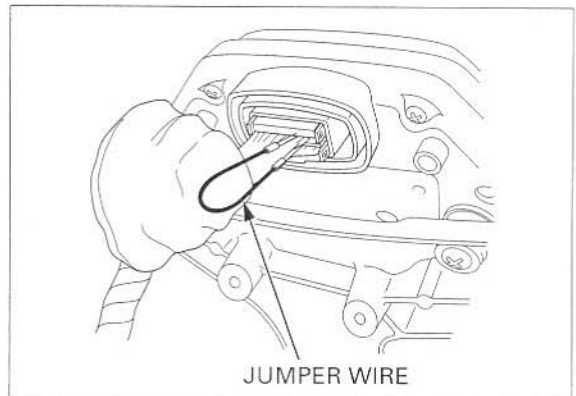

HEADLIGHT RELAY

INSPECTION

Remove the head light (page 20-7).

Disconnect the headlight relay 4P connector, then remove the headlight relay.

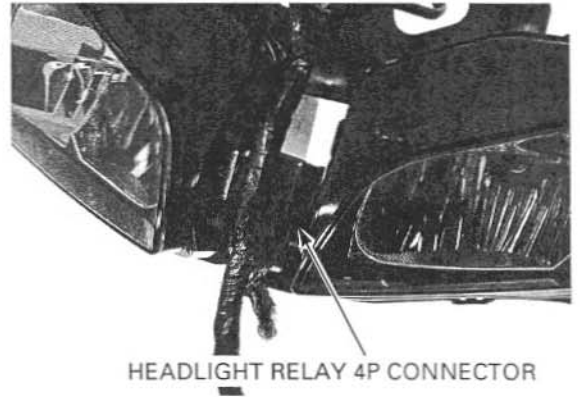

Connect the ohmmeter to the headlight relay connector terminals.

CONNECTION: Black/red – Blue

Connect the 12V battery to the following headlight relay connector terminals.

CONNECTION: White – Green

There should be continuity only when the 12V battery is connected.

If there is no continuity when the 12V battery is connected, replace the headlight relay.

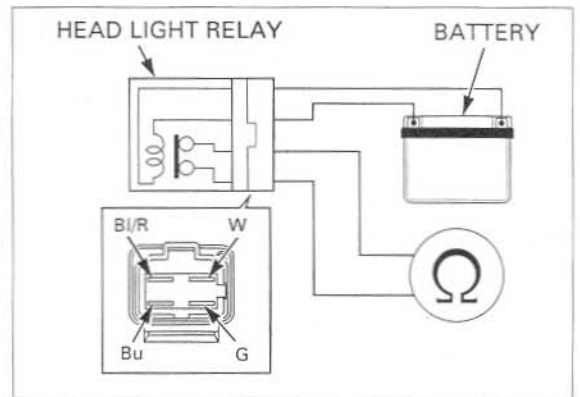

A, AC type

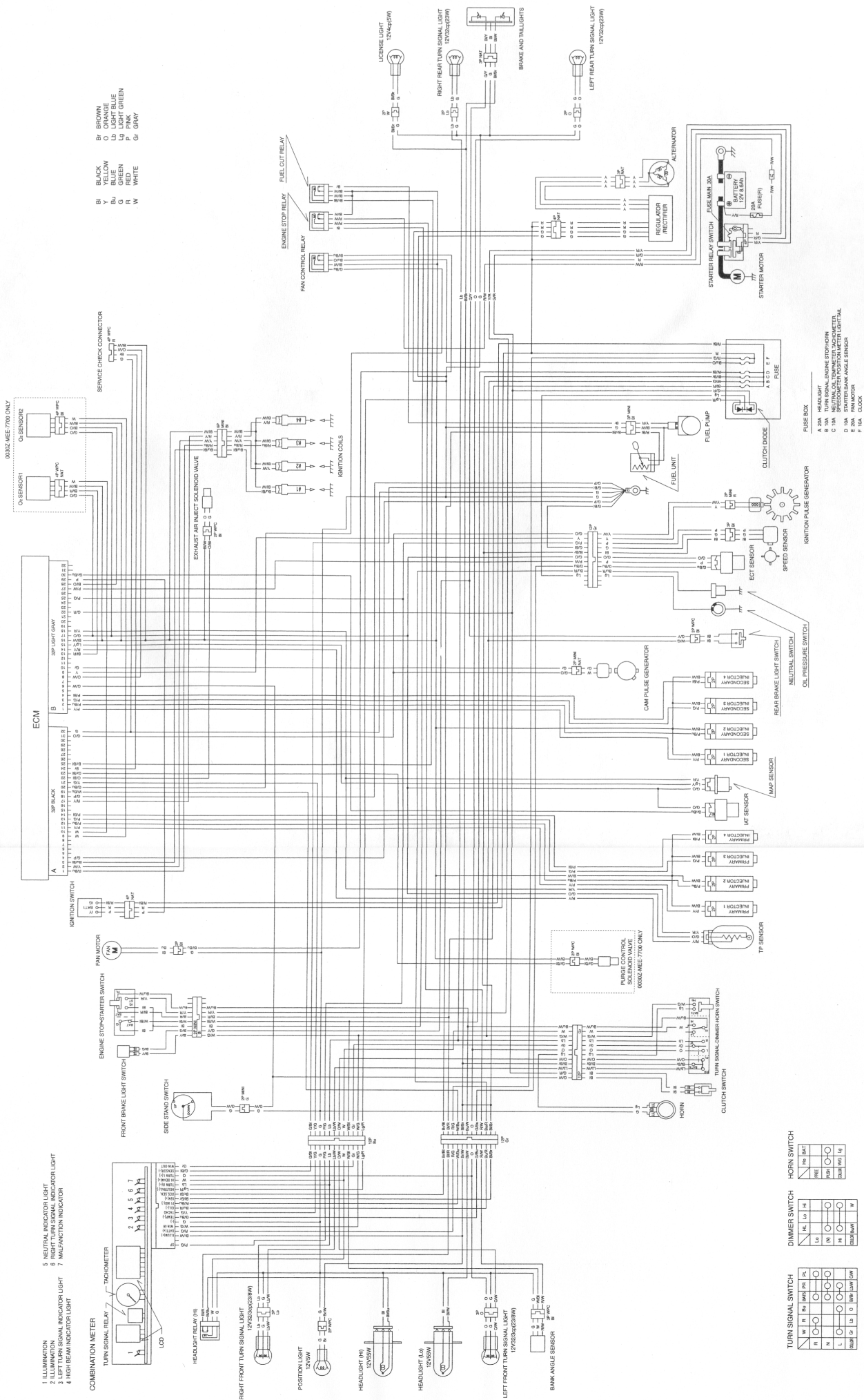

- 1 ILLUMINATION
- 2 NEUTRAL INDICATOR LIGHT
- 3 LEFT TURN SIGNAL INDICATOR LIGHT
- 4 HIGH BEAM INDICATOR LIGHT
- 5 NEUTRAL INDICATOR LIGHT
- 6 NEUTRAL INDICATOR LIGHT
- 7 MALFUNCTION INDICATOR

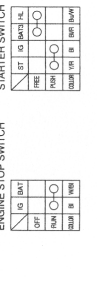
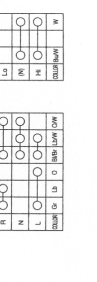
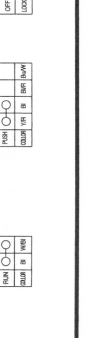
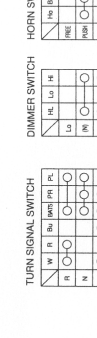
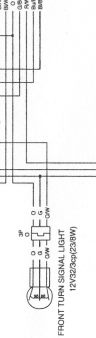
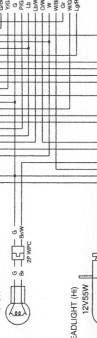
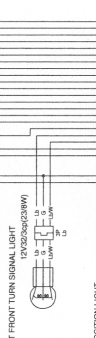
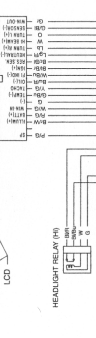
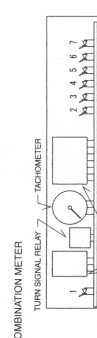

- FUSE BOX
- A HEADLIGHT
 - B TURN SIGNAL ENGINE STOP/HORN
 - C FUEL PUMP
 - D STARTER MOTOR
 - E IGNITION PULSE GENERATOR
 - F IMA CLOCK

22. TROUBLESHOOTING

ENGINE DOES NOT START OR
IS HARD TO START 22-2

ENGINE LACKS POWER 22-3

POOR PERFORMANCE AT LOW
AND IDLE SPEED 22-5

POOR PERFORMANCE AT HIGH SPEED 22-6

POOR HANDLING 22-6

ENGINE DOES NOT START OR IS HARD TO START

1. Spark Plug Inspection

Remove and inspect spark plug.

Are the spark plugs in good condition?

- NO – • Incorrect spark plug heat range
• Incorrect spark plug gap
• Dirty air cleaner

YES – GO TO STEP 2.

2. Spark Test

Perform spark test.

Are there good sparks?

- NO – • Loose or disconnected ignition system wire
• Faulty ignition coil
• Broken or shorted direct ignition coil connector wire
• Faulty ignition pulse generator
• Faulty engine stop switch
• Faulty engine control module (ECM)

YES – GO TO STEP 3.

3. Fuel Pump Inspection

Check for operation of the fuel pump and inspect the fuel flow.

Is the fuel pump unit normal?

- NO – Faulty fuel pump unit (page 6-58).

YES – GO TO STEP 4.

4. Programmed Fuel Injection System Inspection

Check the fuel injection system.

Is the fuel injection system normal?

- NO – Faulty fuel injection system (page 6-79), (page 6-67).

YES – GO TO STEP 5.

5. Cylinder compression Inspection

Test the cylinder compression.

Is the compression specified?

- NO – • *Valve stuck open*
• Worn cylinder and piston rings
• Damaged cylinder head gasket
• Seized valves
• Improper valve timing

YES – GO TO STEP 6.

6. Engine Start Condition

Start by following normal procedure.

Did the engine start but stops?

- YES – • Leaking intake manifold
• Leaking intake pipes
• Faulty starter valves
• Improper ignition timing (Faulty ECM or ignition pulse generator)
• Contaminated fuel

ENGINE LACKS POWER

1. Drive Train Inspection

Raise wheel off the ground and spin by hand.

Did the wheel spin freely?

- NO** – • Brake dragging
• Worn or damaged wheel bearings

YES – GO TO STEP 2.

2. Tire Pressure Inspection

Check the tire pressure.

Is the tire pressure correct?

- NO** – • Faulty tire valve
• Punctured tire

YES – GO TO STEP 3.

3. Clutch Inspection

Accelerate rapidly, shift from first to second.

Did the engine speed change accordingly when clutch is released?

- NO** – • Clutch slipping
• Worn clutch discs/plates
• Warped clutch discs/plates
• Weak clutch spring
• Additive in engine oil

YES – GO TO STEP 4.

4. Engine Performance Inspection

Accelerate lightly.

Did the Engine speed increase?

- NO** – • Dirty air cleaner
• Restricted fuel flow
• Clogged muffler

YES – GO TO STEP 5.

5. Spark Plug Inspection

Remove and inspect spark plugs.

Are the spark plugs in good condition?

- NO** – • Plugs not serviced frequently enough
• Incorrect spark plug heat range
• Incorrect spark plug gap

YES – GO TO STEP 6.

6. Engine Oil Inspection

Check the oil level and condition.

Is the engine oil in good condition?

- NO** – • Oil level too high
• Oil level too low
• Contaminated oil

YES – GO TO STEP 7.

7. Ignition Timing Inspection

Check the ignition timing.

Is the ignition timing as specified?

- NO** – • Faulty engine control module (ECM)
• Faulty ignition pulse generator
• Improper valve timing

YES – GO TO STEP 8.

TROUBLESHOOTING

8. Cylinder compression Inspection

Test the cylinder compression.

Is the compression as specified?

- NO** – • Valve clearance too small
• Valve stuck open
• Worn cylinder and piston rings
• Damaged cylinder head gasket
• Improper valve timing

YES – GO TO STEP 9.

9. Fuel Pump Inspection

Inspect the fuel flow.

Is the fuel pump unit normal?

NO – Faulty fuel pump unit (page 6-58).

YES – GO TO STEP 10.

10. Programmed Fuel Injection System Inspection

Check the fuel injection system.

Is the fuel injection system normal?

NO – Faulty fuel injection system (page 6-79), (page 6-67).

YES – GO TO STEP 11.

11. Lubrication Inspection

Remove cylinder head cover and inspect lubrication.

Is the valve train lubricated properly?

- NO** – • Faulty oil pump
• Faulty pressure regulator valve
• Clogged oil strainer
• Clogged oil passage

YES – GO TO STEP 12.

12. Over Heating Inspection

Check for engine over heating.

Is the engine over heating?

- YES** – • Coolant level too low
• Fan motor not working
• Thermostat stuck closed
• Excessive carbon build-up in combustion chamber
• Use of poor quality fuel
• Wrong type of fuel
• Clutch slipping

NO – GO TO STEP 13.

13. Engine Knocking Inspection

Accelerate or run at high speed.

Is the engine knocking?

- YES** – • Worn piston and cylinder
• Wrong type of fuel
• Excessive carbon build-up in combustion chamber
• Ignition timing too advance (Faulty ECM)
• Faulty ignition pulse generator
• Faulty cam pulse generator

NO – • Engine does not knock

POOR PERFORMANCE AT LOW AND IDLE SPEED

1. Spark Plug Inspection

Remove and inspect spark plugs.

Are the spark plugs in good condition?

NO – • Plugs not serviced frequently enough
• Incorrect spark plug heat range
• Incorrect spark plug gap

YES – GO TO STEP 2.

2. Ignition Timing Inspection

Check the ignition timing.

Is the ignition timing as specified?

NO – • Faulty engine control module (ECM)
• Faulty ignition pulse generator
• Faulty cam pulse generator
• Faulty vehicle speed sensor
• Improper valve timing

YES – GO TO STEP 3.

3. Fuel Pump Inspection

Inspect the fuel flow.

Is the fuel pump unit normal?

NO – Faulty fuel pump unit (page 6-58).

YES – GO TO STEP 4.

4. Programmed Fuel Injection System Inspection

Check the fuel injection system.

Is the fuel injection system normal?

NO – Faulty fuel injection system (page 6-79), (page 6-67).

YES – GO TO STEP 5.

5. Starter Valve Synchronization Inspection

Check the starter valve synchronization.

Is the starter valve synchronization as specified?

NO – Adjust the starter valve synchronization (page 6-86).

YES – GO TO STEP 6.

6. Intake Pipes Leaking Inspection

Check for leaks at the intake manifold pipes.

Are there leaks?

YES – • Loose insulator
• Damaged insulator

POOR PERFORMANCE AT HIGH SPEED

1. Ignition Timing Inspection

Check the ignition timing.

Is the ignition timing as specified?

- NO** – • Faulty engine control module (ECM)
• Faulty ignition pulse generator
• Faulty cam pulse generator
• Faulty vehicle speed sensor
• Improper valve timing

YES – GO TO STEP 2.

2. Fuel Pump Inspection

Inspect the fuel flow.

Is the fuel pump unit operation normal?

NO – Faulty fuel pump unit (page 6-58).

YES – GO TO STEP 3.

3. Programmed Fuel Injection System Inspection

Check the fuel injection system.

Is the fuel injection system operation normal?

NO – Faulty fuel injection system (page 6-79), (page 6-67).

YES – GO TO STEP 4.

4. Valve Timing Inspection

Check the valve timing.

Is the valve timing correct?

NO – Camshafts not installed properly

YES – GO TO STEP 5.

5. Valve Spring Inspection

Check for the valve springs.

Is the valve spring free length as specified?

NO – Faulty valve springs

YES – Not weak

POOR HANDLING

Steering is heavy

- Steering stem adjusting nut too tight
- Damaged steering head bearings
- Low tire pressure

Either wheel is wobbling

- Excessive wheel bearing play
- Bent rim
- Swingarm pivot bearing excessively worn
- Bent frame

The motorcycle pulls to one side

- Front and rear wheel not aligned
- Faulty shock absorber
- Bent fork
- Bent swingarm
- Bent axle
- Bent frame

23. INDEX

ABSOLUTE PRESSURE FUEL SUPPLY SYSTEM	2-2	DTC TROUBLESHOOTING	6-37
AIR CLEANER	4-6	DUAL SEQUENTIAL FUEL INJECTION SYSTEM	
AIR CLEANER HOUSING	6-64	(PGM-DSFI)	2-3
AIR DUCT COVERS	3-9	ECT SENSOR	
ALTERNATOR CHARGING COIL	17-9	LIGHT/METER/SWITCH	20-16
ALTERNATOR COVER INSTALLATION	11-7	ECT/THERMO SENSOR	
ALTERNATOR COVER REMOVAL	11-4	FUEL SYSTEM (Programmed Fuel Injection)	6-89
BANK ANGLE SENSOR	6-93	ELECTRIC STARTER SPECIFICATIONS	1-10
BATTERY	17-5	EMISSION CONTROL INFORMATION LABELS	
BATTERY TRAY	17-7	(U.S.A. only)	1-39
BATTERY/CHARGING SYSTEM SPECIFICATIONS	1-10	EMISSION CONTROL SYSTEMS	1-36
BODY PANEL LOCATIONS	3-2	ENGINE & FRAME TORQUE VALUES	1-12
BRAKE FLUID	4-25	ENGINE CONTROL MODULE (ECM)	
BRAKE FLUID REPLACEMENT/AIR BLEEDING	16-6	FUEL SYSTEM (Programmed Fuel Injection)	6-94
BRAKE LIGHT SWITCH		ENGINE DOES NOT STAR OR IS HARD TO START ...	22-2
LIGHTS/METERS/SWITCHES	20-21	ENGINE IDLE SPEED	4-18
MAINTENANCE	4-27	ENGINE INSTALLATION	8-10
BRAKE PAD WEAR	4-26	ENGINE LACKS POWER	22-3
BRAKE PAD/DISC	16-9	ENGINE OIL/OIL FILTER	4-15
BRAKE PEDAL	16-29	ENGINE REMOVAL	8-5
BRAKE SYSTEM	4-26	ENGINE STOP RELAY	6-94
BRAKE/TAIL LIGHT	20-9	EVAP PURGE CONTROL VALVE	
CABLE & HARNESS ROUTING	1-22	(California type only)	6-98
CAM CHAIN TENSIONER LIFTER	9-34	EVAPORATIVE EMISSION CONTROL SYSTE	
CAM PULSE GENERATOR	6-90	(CALIFORNIA TYPE ONLY)	4-20
CAMSHAFT INSTALLATION	9-26	EXHAUST PIPE	3-24
CAMSHAFT REMOVAL	9-8	FAN CONTROL RELAY	7-18
CHARGING SYSTEM INSPECTION	17-9	FAST IDLE WAX UNIT	6-81
CLUTCH	10-7	FLYWHEEL	11-5
CLUTCH SWITCH	20-21	FORK	14-18
CLUTCH SYSTEM	4-28	FRONT BRAKE CALIPERS	16-22
CLUTCH/STARTER CLUTCH/		FRONT FENDER	3-15
GEARSHIFT LINKAGE SPECIFICATIONS	1-7	FRONT MASTER CYLINDER	16-13
COMBINATION METER	20-11	FRONT WHEEL	14-12
COMPONENT LOCATION		FRONT WHEEL/SUSPENSION/STEERING	
ALTERNATOR	11-2	SPECIFICATIONS	1-9
CLUTCH/STARTER CLUTCH/		FUEL CUT-OFF RELAY	6-60
GEARSHIFT LINKAGE	10-2	FUEL LEVEL SENSOR	20-18
CRANKCASE/TRANSMISSION	12-2	FUEL LINE	4-5
CRANKSHAFT/PISTON/CYLINDER	13-2	FUEL LINE INSPECTION	6-56
CYLINDER HEAD/VALVES	9-2	FUEL PUMP UNIT	6-58
ENGINE REMOVAL/INSTALLATION	8-2	FUEL SYSTEM (Programmed Fuel Injection)	
FRONT WHEEL/SUSPENSION/STEERING	14-2	SPECIFICATIONS	1-6
FUEL SYSTEM (Programmed Fuel Injection)	6-2	FUEL TANK	6-61
HYDRAULIC BRAKE	16-2	FUEL TANK COVER	3-15
REAR WHEEL SUSPENSION	15-2	GEARSHIFT LINKAGE	10-22
COOLANT REPLACEMENT	7-6	GENERAL SPECIFICATIONS	1-4
COOLING SYSTEM	4-19	HANDLEBAR SWITCHES	20-20
COOLING SYSTEM SPECIFICATIONS	1-6	HANDLEBARS	14-7
CRANKCASE ASSEMBLY	12-16	HEADLIGHT	20-6
CRANKCASE SEPARATION	12-5	HEADLIGHT AIM	4-28
CRANKCASE/TRANSMISSION SPECIFICATIONS	1-8	HEADLIGHT RELAY	20-25
CRANKPIN BEARING	13-11	HORN	20-24
CRANKSHAFT	13-5	HYDRAULIC BRAKE SPECIFICATIONS	1-10
CRANKSHAFT/PISTON/CYLINDER SPECIFICATIONS ..	1-8	IAT SENSOR	6-89
CYLINDER COMPRESSION TEST	9-6	IGNITION PULSE GENERATOR	18-7
CYLINDER HEAD ASSEMBLY	9-22	IGNITION SWITCH	20-19
CYLINDER HEAD COVER ASSEMBLY	9-31	IGNITION SYSTEM INSPECTION	18-5
CYLINDER HEAD COVER DISASSEMBLY	9-7	IGNITION SYSTEM SPECIFICATIONS	1-10
CYLINDER HEAD COVER INSTALLATION	9-32	IGNITION TIMING	18-7
CYLINDER HEAD COVER REMOVAL	9-6	LICENCE LIGHT	20-10
CYLINDER HEAD DISASSEMBLY	9-15	LIGHTS	20-2
CYLINDER HEAD INSPECTION	9-16	LIGHTS/METERS/SWITCHES	20-2
CYLINDER HEAD INSTALLATION	9-24	LIGHTS/METERS/SWITCHES SPECIFICATIONS	1-11
CYLINDER HEAD REMOVAL	9-13	LOWER COWLS	3-6
CYLINDER HEAD/VALVES SPECIFICATIONS	1-7	LOWER INJECTOR	6-79
DIODE	19-14	LUBRICATION & SEAL POINTS	1-19
DRIVE CHAIN	4-21	LUBRICATION SYSTEM DIAGRAM	5-2
DTC CODE INDEX	6-33	LUBRICATION SYSTEM SPECIFICATIONS	1-6

INDEX

- MAIN JOURNAL BEARING..... 13-8
MAINTENANCE SCHEDULE..... 4-4
MAP SENSOR..... 6-88
MIDDLE COWLS..... 3-7
MIL CODE INDEX..... 6-12
MIL TROUBLESHOOTING..... 6-15
MODEL IDENTIFICATION..... 1-2
MUFFLER..... 3-20
NEUTRAL SWITCH..... 20-22
NUTS, BOLTS, FASTENERS..... 4-33
O2 SENSOR (California type only)..... 6-99
OIL COOLER..... 5-12
OIL PRESSURE INSPECTION..... 5-5
OIL PRESSURE SWITCH..... 20-16
OIL PUMP..... 5-8
OIL STRAINER/PRESSURE RELIEF VALVE..... 5-6
PAIR CONTROL SOLENOID VALVE..... 6-96
PASSENGER SEAT..... 3-4
PGM-FI SELF-DIAGNOSIS INFORMATION..... 6-8
PISTON/CYLINDER..... 13-13
POOR HANDLING..... 22-6
POOR PERFORMANCE AT HIGH SPEED..... 22-6
POOR PERFORMANCE AT LOW AND IDLE SPEED..... 22-5
POSITION LIGHT..... 20-7
RADIATOR..... 7-10
RADIATOR COOLANT..... 4-18
RADIATOR RESERVE TANK..... 7-17
REAR BRAKE CALIPER..... 16-26
REAR COWL..... 3-5
REAR FENDER..... 3-16
REAR MASTER CYLINDER..... 16-18
REAR WHEEL..... 15-8
REAR WHEEL/SUSPENSION SPECIFICATIONS..... 1-9
REGULATOR/RECTIFIER..... 17-10
RIGHT CRANKCASE COVER INSTALLATION..... 10-24
RIGHT CRANKCASE COVER REMOVAL..... 10-5
SEAT..... 3-4
SEAT RAIL..... 3-18
SECONDARY AIR SUPPLY SYSTEM..... 4-19
SERVICE INFORMATION
ALTERNATOR..... 11-3
BATTERY/CHARGING SYSTEM..... 17-3
CLUTCH/STARTER CLUTCH/
GEARSHIFT LINKAGE..... 10-3
COOLING SYSTEM..... 7-3
CRANKCASE/TRANSMISSION..... 12-3
CRANKSHAFT/PISTON/CYLINDER..... 13-3
CYLINDER HEAD/VALVES..... 9-3
ELECTRIC STARTER..... 19-3
ENGINE REMOVAL/INSTALLATION..... 8-3
FRAME/BODY PANELS/EXHAUST SYSTEM..... 3-3
FRONT WHEEL/SUSPENSION/STEERING..... 14-3
FUEL SYSTEM (Programmed Fuel Injection)..... 6-3
HYDRAULIC BRAKE..... 16-4
IGNITION SYSTEM..... 18-3
LIGHTS/METERS/SWITCHES..... 20-3
LUBRICATION SYSTEM..... 5-3
MAINTENANCE..... 4-2
REAR WHEEL SUSPENSION..... 15-3
SERVICE RULES..... 1-2
SHIFT FORK/SHIFT DRUM/TRANSMISSION..... 12-7
SHOCK ABSORBER..... 15-15
SIDE COVERS..... 3-4
SIDE STAND..... 4-29
SIDE STAND SWITCH..... 20-22
SPARK PLUG..... 4-7
SPEEDOMETER/VEHICLE SPEED SENSOR..... 20-13
STANDARD TORQUE VALUES..... 1-12
STARTER CLUTCH..... 10-17
STARTER MOTOR..... 19-6
STARTER RELAY SWITCH..... 19-12
STARTER VALVE..... 6-82
STARTER VALVE SYNCHRONIZATION..... 6-86
STATOR..... 11-4
STEERING HEAD BEARINGS..... 4-34
STEERING STEM..... 14-27
SUSPENSION..... 4-29
SUSPENSION LINKAGE..... 15-18
SWINGARM..... 15-21
SYSTEM DIAGRAM
BATTERY/CHARGING SYSTEM..... 17-2
ELECTRIC STARTER..... 19-2
FUEL SYSTEM (Programmed Fuel Injection)..... 6-7
IGNITION SYSTEM..... 18-2
SYSTEM FLOW PATTERN..... 7-2
SYSTEM LOCATION
FUEL SYSTEM (Programmed Fuel Injection)..... 6-6
LIGHTS/METERS/SWITCHES..... 20-2
SYSTEM TESTING..... 7-5
TACHOMETER..... 20-14
THERMOSTAT..... 7-8
THROTTLE BODY..... 6-72
THROTTLE OPERATION..... 4-6
TP SENSOR..... 6-91
TROUBLESHOOTING
BATTERY/CHARGING SYSTEM..... 17-4
CLUTCH/STARTER CLUTCH/
GEARSHIFT LINKAGE..... 10-4
COOLING SYSTEM..... 7-4
CRANKCASE/TRANSMISSION..... 12-4
CRANKSHAFT/PISTON/CYLINDER..... 13-4
CYLINDER HEAD/VALVES..... 9-5
ELECTRIC STARTER..... 19-4
FRAME/BODY PANELS/EXHAUST SYSTEM..... 3-3
FRONT WHEEL/SUSPENSION/STEERING..... 14-6
FUEL SYSTEM (Programmed Fuel Injection)..... 6-5
HYDRAULIC BRAKE..... 16-5
IGNITION SYSTEM..... 18-4
LIGHTS/METERS/SWITCHES..... 20-5
LUBRICATION SYSTEM..... 5-4
REAR WHEEL SUSPENSION..... 15-7
TURN SIGNAL..... 20-8
TURN SIGNAL RELAY..... 20-24
UNIT PROLINK SUSPENSION..... 2-4
UPPER COWL..... 3-9
UPPER INJECTOR..... 6-67
VALVE CLEARANCE..... 4-11
VALVE GUIDE REPLACEMENT..... 9-19
VALVE SEAT INSPECTION/REFACING..... 9-19
WATER PUMP..... 7-15
WHEELS/TIRES..... 4-33
WIRING DIAGRAMS
A, AC type..... 21-3