



***X-PLANE 11 GUIDE
FLYSIM
BOEING 727-100***

BY CHUCK
LAST UPDATED: 13/06/2019

TABLE OF CONTENTS

- PART 1 – INTRODUCTION
- PART 2 – COCKPIT LAYOUT
- PART 3 – FLIGHT PLANNING
- PART 4 – START-UP PROCEDURE
- PART 5 – TAXI
- PART 6 – TAKEOFF, CLIMB & CRUISE
- PART 7 – AUTOPILOT
- PART 8 – APPROACH & LANDING

PLATFORM: X-PLANE 11



The **Boeing 727** is a mid-sized, narrow-body tri-engine jet aircraft built by Boeing Commercial Airplanes from the early 1960s to 1984. It can carry 149 to 189 passengers and later models can fly up to 2,700 nautical miles nonstop. Intended for short and medium-length flights, the 727 can use relatively short runways at smaller airports. It has three Pratt & Whitney JT8D engines below the T-tail, one on each side of the rear fuselage with a center engine that connects through an S-duct to an inlet at the base of the fin. The 727 is Boeing's only trijet aircraft.

The Boeing 727 design was a compromise among United Airlines, American Airlines, and Eastern Air Lines; each of the three had developed requirements for a jet airliner to serve smaller cities with shorter runways and fewer passengers. United Airlines requested a four-engine aircraft for its flights to high-altitude airports, especially its hub at Stapleton International Airport in Denver, Colorado. American Airlines, which was operating the four-engined Boeing 707 and Boeing 720, requested a twin-engined aircraft for efficiency. Eastern Airlines wanted a third engine for its overwater flights to the Caribbean, since at that time twin-engine commercial flights were limited by regulations to routes with 60-minute maximum flying time to an airport. Eventually, the three airlines agreed on a trijet design for the new aircraft.

The 727 was designed for smaller airports, so independence from ground facilities was an important requirement. This led to one of the 727's most distinctive features: the built-in airstair that opens from the rear underbelly of the fuselage, which initially could be opened in flight. Hijacker D. B. Cooper used this hatch when he parachuted from the back of a 727, as it was flying over the Pacific Northwest. Boeing subsequently modified the design with the Cooper vane so that the airstair could not be lowered in flight. Another innovation was the auxiliary power unit (APU), which allowed electrical and air-conditioning systems to run independently of a ground-based power supply, and without having to start one of the main engines. An unusual design feature is that the APU is mounted in a hole in the keel beam web, in the main landing gear bay.

At the start of the 21st century, the 727 remained in service with a few large airlines. Faced with higher fuel costs, lower passenger volumes due to the post-9/11 economic climate, increasing restrictions on airport noise, and the extra expenses of maintaining older planes and paying flight engineers' salaries, most major airlines phased out their 727s; they were replaced by twin-engined aircraft, which are quieter and more fuel-efficient. Modern airliners also have a smaller flight deck crew of two pilots, while the 727 required two pilots and a flight engineer. Delta Air Lines, the last major U.S. carrier to do so, retired its last 727 from scheduled service in April 2003.



The 727 required a crew of three: a pilot, a co-pilot and a flight engineer. This is something that I think is truly special about this aircraft: the workload to get this aircraft flying well is quite high. There is definitely a lot to do in there during the whole flight. You will never get bored, trust me. The lack of autothrottle makes the use and monitoring of the autopilot a full-time job by itself. This is a pilot's aircraft; flying it is quite enjoyable and the engines require quite a bit of babysitting in order to avoid damaging them. Flying approaches can be challenging at times in high crosswind conditions, but the 727 gets the job done. This simulation by FlyJSim is a trip back through time and is well worth the time spent learning its aging systems and rustic interfaces.

This plane feels old. Hell, even the CIVA (Delco Carousel IV-A) that can be equipped in the cockpit feels like something that no one knows how to use anymore. Researching information on that plane felt like a history lesson just as much as a lesson on where this myth about the “golden age of aviation” comes from.

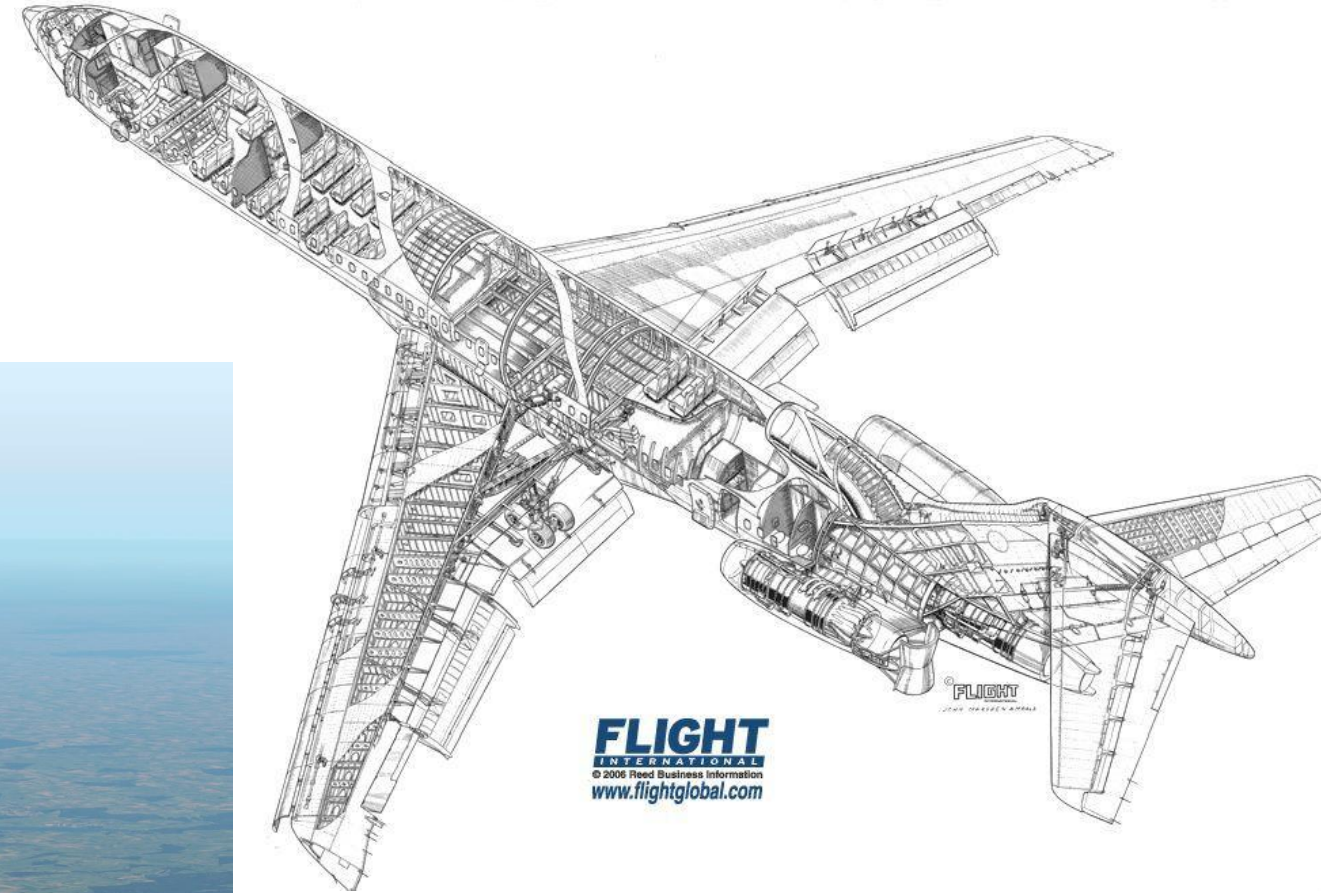
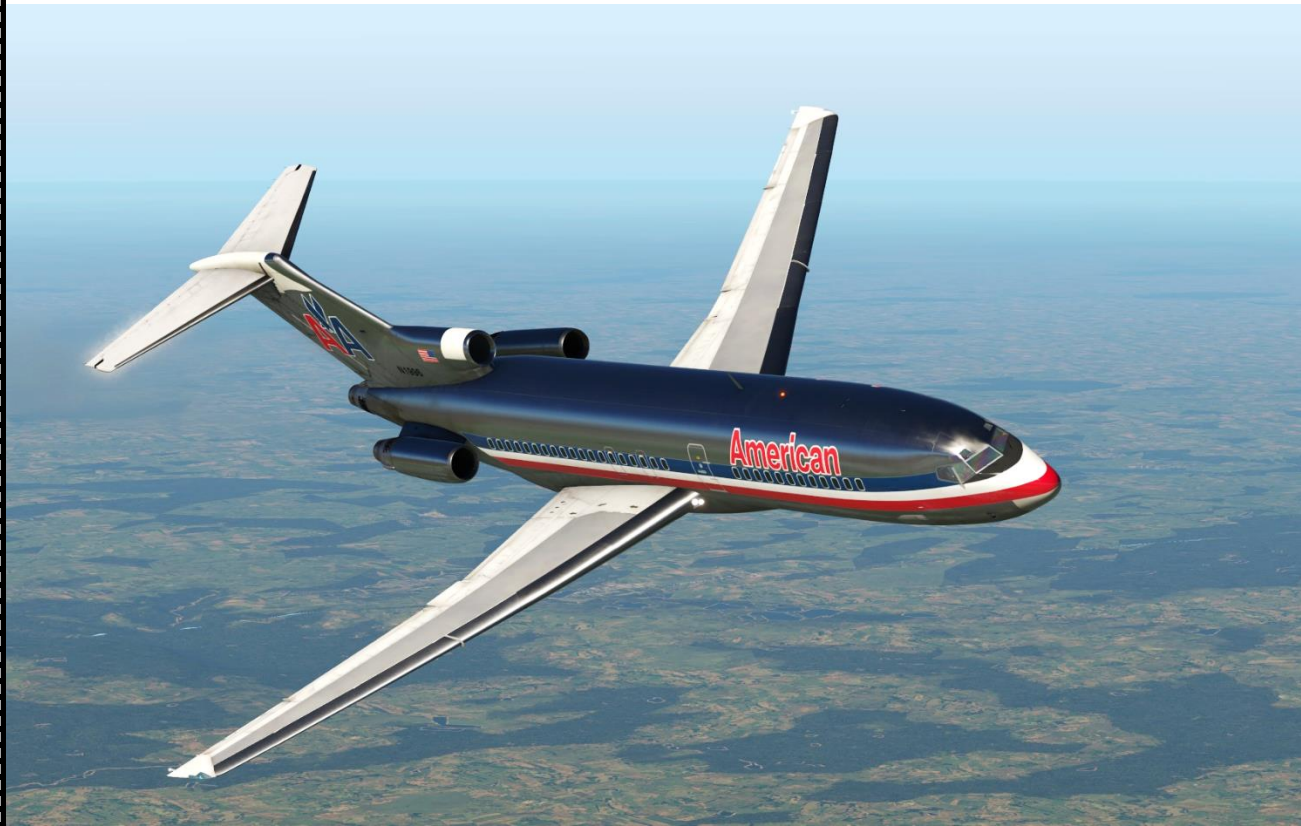

I believe Jessica Bannister-Pearce from Mutley's hangar summed up my thoughts exactly:

"For the descent and approach I find out that the beauty of the 727 comes at a price. Despite pulling the throttles back to idle, the aircraft picks up speed descending. She's one slippery old girl and I use a little speedbrake to slow down. Once you get level again though, bleeding off the speed is still a little tricky. You constantly find yourself having to think well ahead of the aircraft to get the right speed settings as you approach the airfield. However, once you get it right, the 727 will be like putty in your hands. With full flaps and gear down, the aircraft is remarkably stable, yet nimble, feeling very much like a big C172. It's easy to control the approach and landing the old girl feels like a real accomplishment, though slowing her down even with full reverse and full brakes is a bit difficult. The 727 is rapidly becoming a piece of aviation history. So to get a flight sim representation of the old girl as good as the FlyJSim one is a rare treat. She flies by the numbers, sounds like the real thing and looks prettier than the swimsuit contest of miss world."

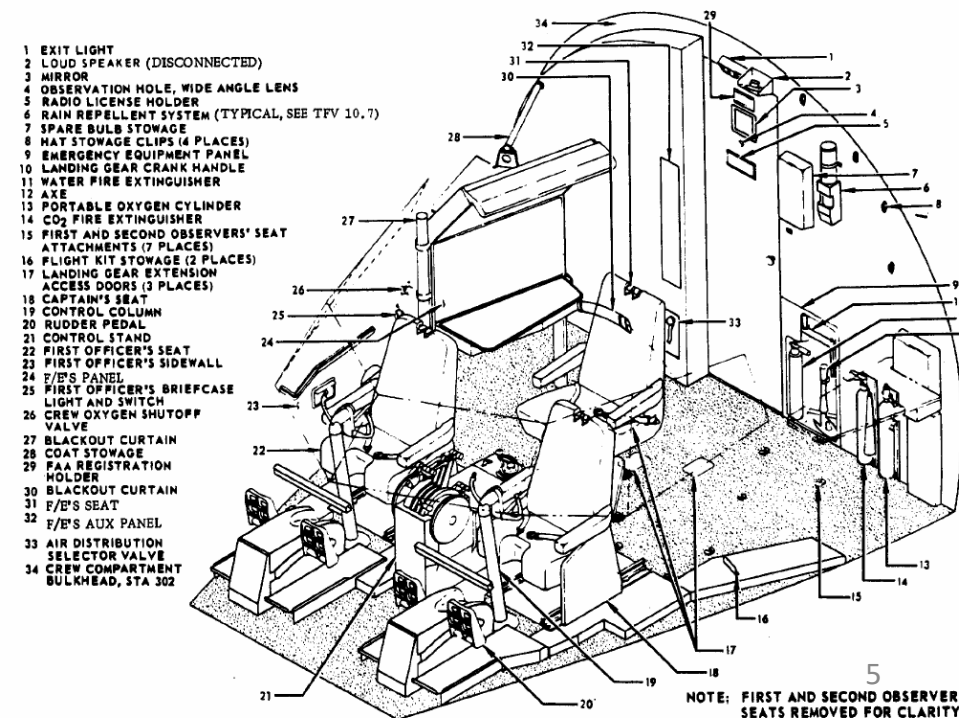
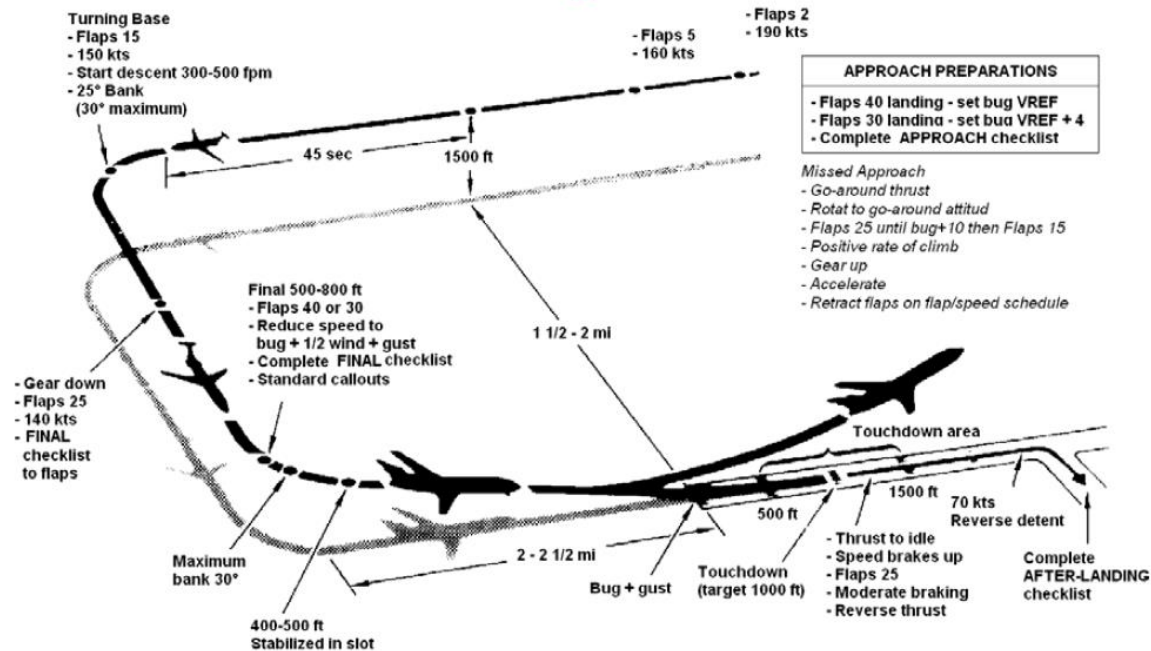



727-100

TUTORIAL STRUCTURE

Before you even step foot in your virtual cockpit, you need to know where you are, where you are going, how you will get there, what you need to get there. This document is structured like a short tutorial flight.

The flight tutorial is structured as follows:

- Familiarize yourself with the cockpit layout
- Plan your flight
 - Determine the flight route, fuel & cargo loads
 - Spawn the aircraft and set it in a Cold & Dark state
 - Provide aircraft with power
 - Program the CIVA (Delco Carousel IV-A INS system)
- Start-up the aircraft and make it ready for flight
- Taxi
- Takeoff
- Climb and cruise
- Explore autopilot capabilities
- Descend, approach and land



727-100

BEST RESOURCES

DISCLAIMER: Do not use this guide for real life flying. I mean it.

FlyJSim's 727 Manual

CIVA Tutorial by TheAlmightySnark (Mudspike)

<http://www.mudspike.com/civa-ins-navigation-tutorial/>

Aviation For All's Aircraft Operating Manual for the Boeing 727-200

http://www.aviationforall.com/wp-content/uploads/2016/09/AOM_727_200_Sim_Copy.pdf

Boeing 727-200 CBT (Computer Based Training)

<https://www.youtube.com/watch?v=Nn-6OvMXvG4&list=PLpNS2WzxM5y3XaG9jMK6fArNGXdBwgWJC>

Froogle Sims 727 First Impressions (Two Parts) (Youtube)

Part 1 (Takeoff): <https://youtu.be/ThVQDObYKNY>

Part 2 (Landing): https://youtu.be/Cs1_akSNCcY

15 NM ARC – Cold and Dark Tutorial (Youtube)

<https://youtu.be/ZkS0n0QoUIk>

PART 2 – COCKPIT LAYOUT

727-100 





Cockpit Utility Light
Can be rotated



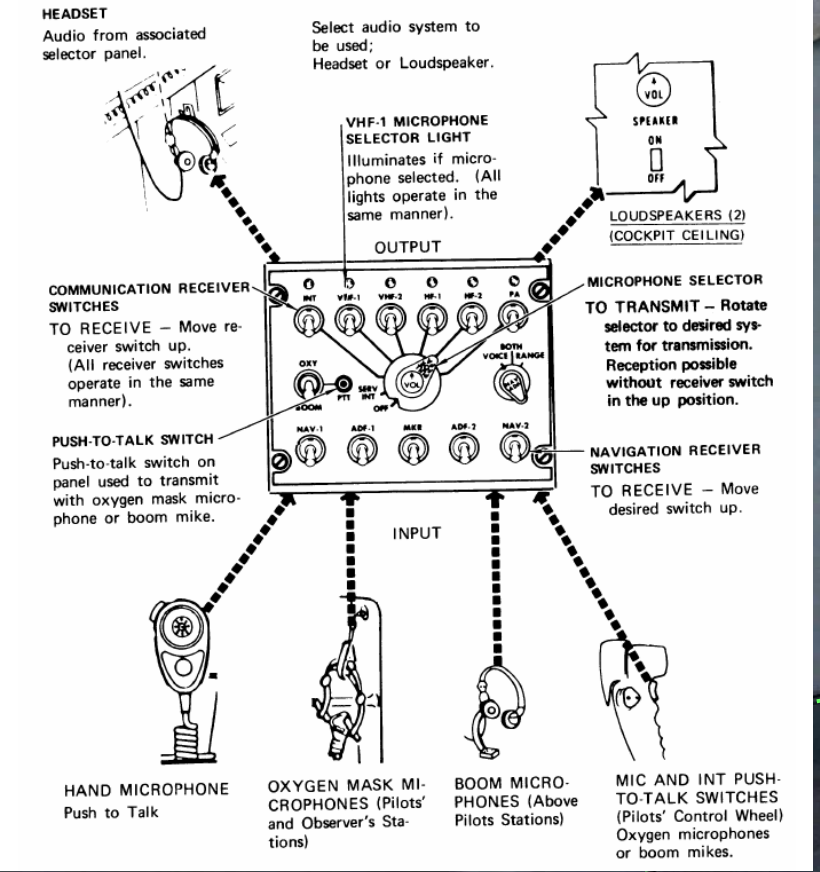

Nose Wheel Steering Tiller
Used to steer aircraft on the ground

Microphone Selector Lights
(Illuminated if microphone is selected)

Audio Panel Volume Tuner

Audio Panel Volume Tuner

Audio Selector Panel

Audio Communication Receiver Selector Switches
VHF-1, VHF-2, VHF-3 radios
SERV INT: Ground Services Intercom
INT: Intercom
PA: Passenger Address

Audio Navigation System Receiver Selector Switches
NAV-1, NAV-2: Radio Navigation
DME-1, DME-2: Distance Measuring Equipment
ADF-1, ADF-2: Automatic Direction Finder

Microphone Selector
Selects which audio receiver microphone is transmitting to

GROSS WEIGHT 1000 LBS	REFERENCE SPEED	
	V _{REF} 30	V _{REF} 40
165	139	-
160	137	-
155	135	-
150	133	-
145	129	-
140	127	124
135	125	121
130	122	118
125	119	116
120	117	113
115	114	110
110	111	107
105	109	105
100	106	102



GROSS WT 1000 LB	REFERENCE SPEED	
	V _{REF} 30	V _{REF} 40
165	139	-
160	137	-
155	135	-
150	133	-
145	129	-
140	127	124
135	125	121
130	122	118
125	119	116
120	117	113
115	114	110
110	111	107
105	109	105
100	106	102

AFTER TAKEOFF NORMAL MANEUVERING SPEEDS -KTS IAS		
FLAPS	BELOW MAX LANDING WT	ABOVE MAX LANDING WT
0	200	210
2	190	200
5	160	170
15	150	160
25	140	150

* Maximum Operating Speed	MODE A (and all airplanes not dual V _{mo} equipped) V _{mo} : 380 kts. at sea level 389 kts. at 5,000 ft. 398 kts. at 10,000 ft. 404 kts. at 15,000 ft. 409 kts. at 20,000 ft. 411 kts. at 21,500 ft. M _{mo} : .90 Mach above 21,500 ft.	MODE B When in-flight gross weight exceeds 172,000 pounds or ZFW exceeds 136,000 pounds, operate in V _{mo} MODE B for the entire flight (AFM). V _{mo} : 350 kts. at sea level 352 kts. at 5,000 ft. 355 kts. at 10,000 ft. 359 kts. at 15,000 ft. 363 kts. at 20,000 ft. 369 kts. at 25,000 ft. 372 kts. at 26,500 ft. M _{mo} : .90 Mach above 26,500 ft.
---------------------------	--	---

MACH Airspeed Warning System Test Switch
 No. 1 System is linked to the auxiliary pitot-static system, No.2 System is linked to the copilot's pitot-static system. The "Clacker" sound will be heard when holding the switch.

Airspeed Warning System Mode Switch
 Mode A or Mode B are used based on in-flight Gross Weight (GW) or Zero Fuel Weight (ZFW).

Windshield Air Knob

Foot Air Knob

AFTER TAKEOFF NORMAL MANEUVERING SPEEDS KTS IAS		
FLAPS (DEG)	BELOW MAX LANDING WEIGHT	ABOVE MAX LANDING WEIGHT
0	200	210
2	190	200
5	160	170
15	150	160
25	140	150

NOTE: FOR MANEUVERS IMMEDIATELY AFTER TAKE-OFF EXCEEDING 15 DEG BANK, MAINTAIN AT LEAST V₂ + 10 KTS AT TAKE-OFF FLAPS



Stabilizer Trim
(Nose Up / Nose Down)

Aileron Trim Indicator

Memory Device Dials for Flight Number
Note: In the real airplane, these dials are rotated to the last three digits of the flight number (i.e. Flight 1158) in order to remember it when talking to the ATC (Air Traffic Controller)

Autopilot Disengage Button

Control Wheel / Yoke

Control Column

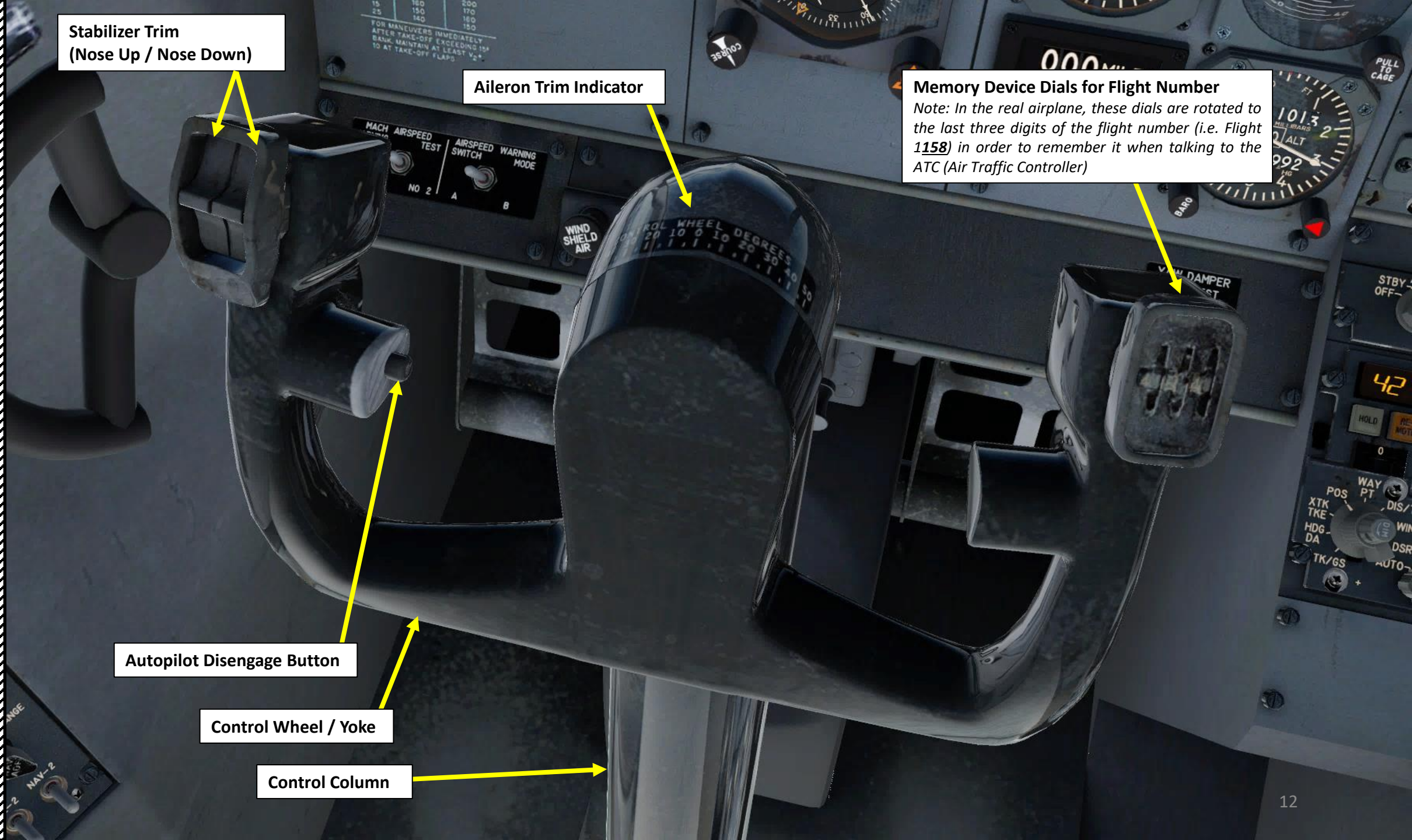

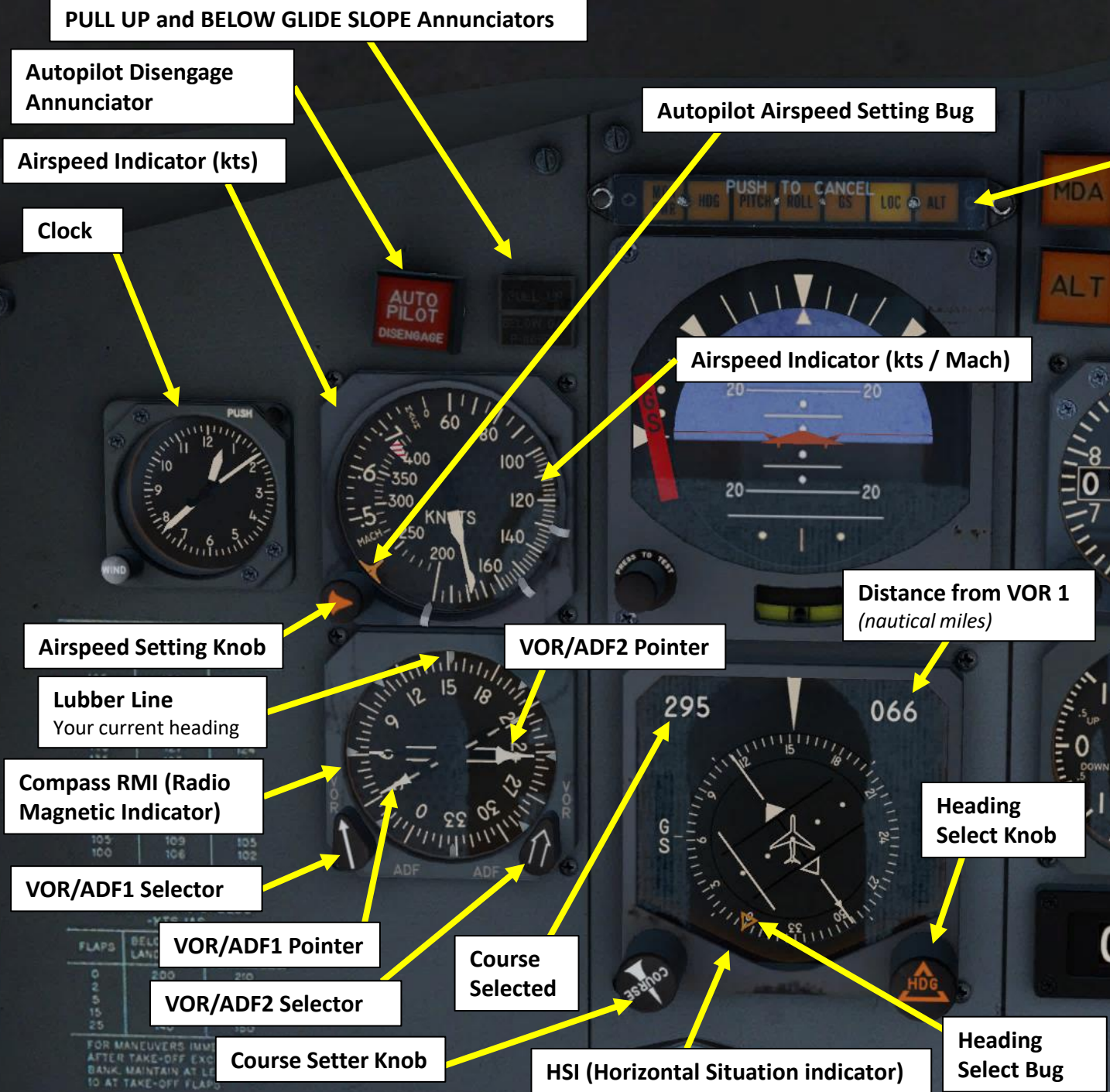

Instrument Comparator Lights
 Illuminated when flight instrument being compared (pilot vs first officer) have exceeded established tolerances. Push to dim lights.

- MON PWR: Monitor Power, 115 volt AC power loss to comparator unit
- HDG: Heading (HSI)
- PITCH: Pitch (ADI)
- ROLL: Roll (ADI)
- GS: Glide Slope deviation from No. 1 & No. 2 VHF navigation unit
- LOC: Localizer Slope deviation from No. 1 & No. 2 VHF navigation unit
- ALT: Altitude (Altimeter)

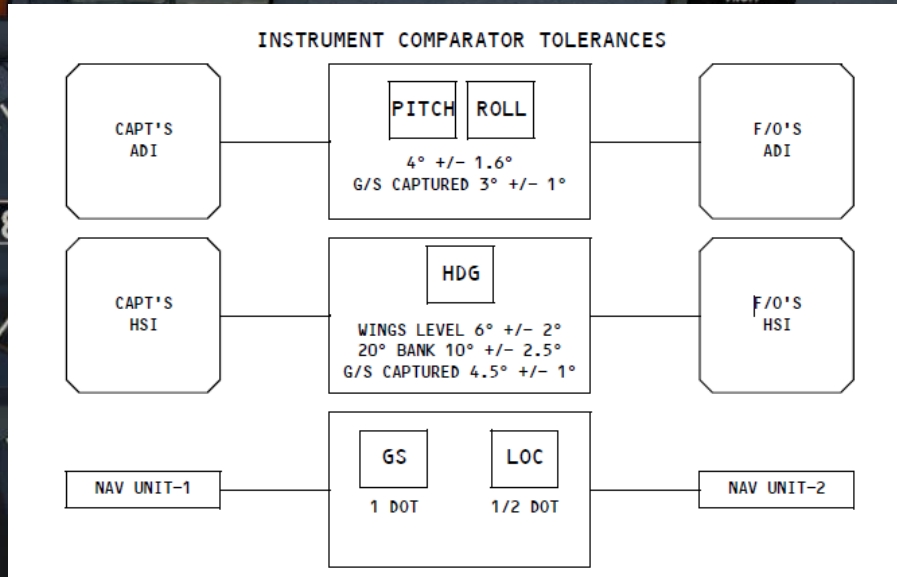

NOTE:
 The Instrument Comparator is basically what preceded what we know today as EFIS (Electronic Flight Instrument System). Early "Classic" Boeing 727s and Boeing 737s had traditional (electromechanical) displays, which are equipped with synchro mechanisms that transmit the pitch, roll, and heading shown on the captain and first officer's instruments to an instrument comparator. The comparator warns of excessive differences between the Captain and First Officer displays. Even a fault as far downstream as a jam in, say, the roll mechanism of an ADI triggers a comparator warning, the instrument comparator thus provides both comparator monitoring and display monitoring.

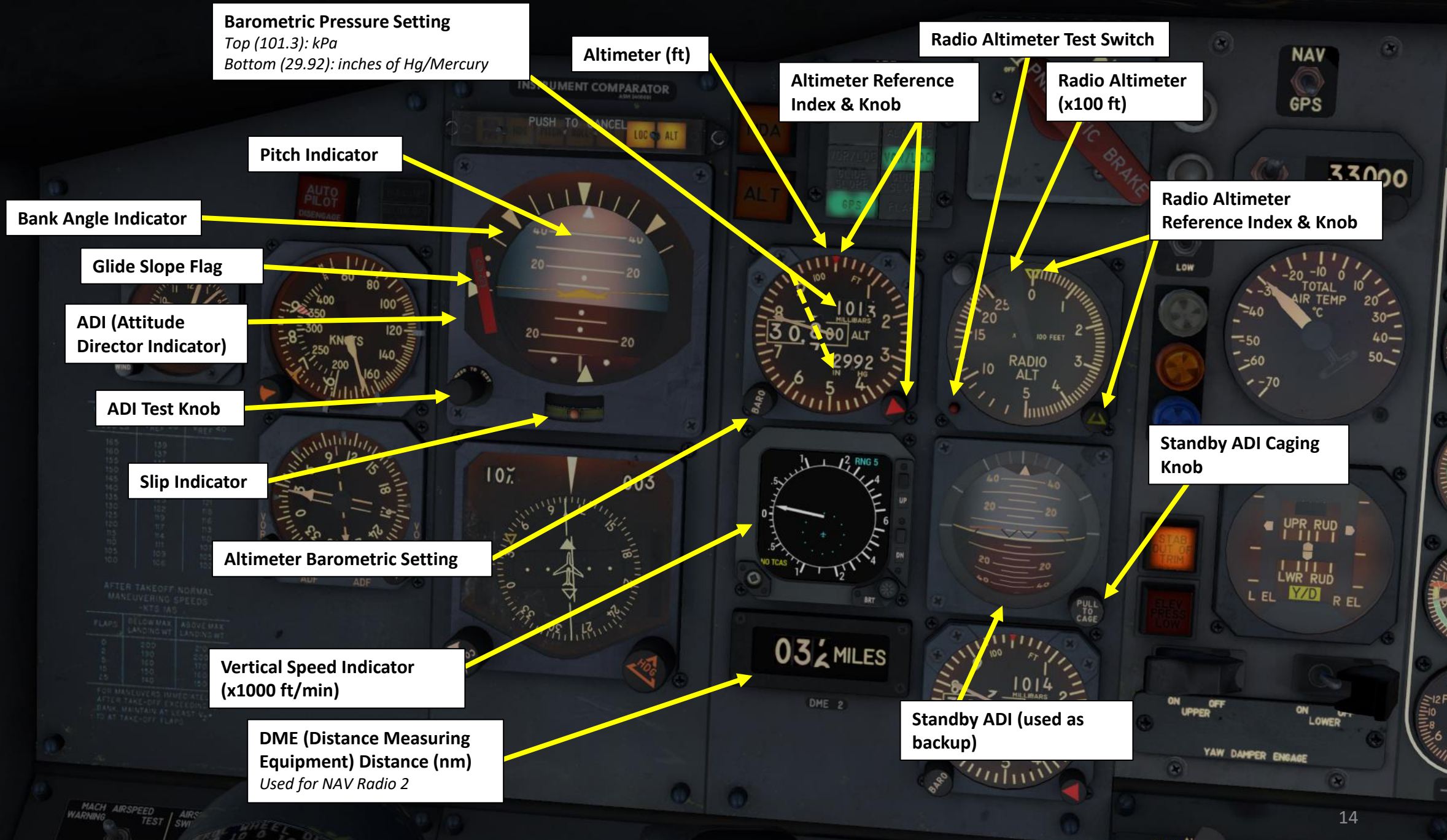

Barometric Pressure Setting
Top (101.3): kPa
Bottom (29.92): inches of Hg/Mercury

Altimeter (ft)

Radio Altimeter Test Switch

Altimeter Reference Index & Knob

Radio Altimeter (x100 ft)

Pitch Indicator

Bank Angle Indicator

Glide Slope Flag

ADI (Attitude Director Indicator)

ADI Test Knob

Slip Indicator

Altimeter Barometric Setting

Vertical Speed Indicator (x1000 ft/min)

DME (Distance Measuring Equipment) Distance (nm)
Used for NAV Radio 2

Radio Altimeter Reference Index & Knob

Standby ADI Caging Knob

Standby ADI (used as backup)

APD (Approach Progress Display) for Autopilot (A/P) and Flight Director (F/D)

- GO AROUND
- ALT SELECT
- ALT
- HDG
- VOR/LOC
- GLIDE SLOPE
- GPS
- FLARE

Note: Amber means ARMED, Green Means CAPTURED.

Pneumatic Emergency Brake Lever

Autopilot Altitude Selector Unit Mode (Hundreds/Thousands)

GPS/NAV Selector Switch (added with Version 3)

Selects input to navigation system.

- "GPS" is used for a third-party FMC (Flight Management Computer) or CIVA (Delco Carousel IV-A).
- "NAV" is used for VORs set up on the NAV radio-navigation radios.

MDA (Mean Decision Altitude) Annunciator

Altitude Alert Annunciator

Marker Beacon Sensitivity Switch (High/Low Sensitivity)

Marker Beacon Light: Airways Marker

Marker Beacon Light: Middle Marker

Marker Beacon Light: Outer Marker

Autopilot Altitude Select Indicator (ft)

TOT (Total Air Temperature) Indicator

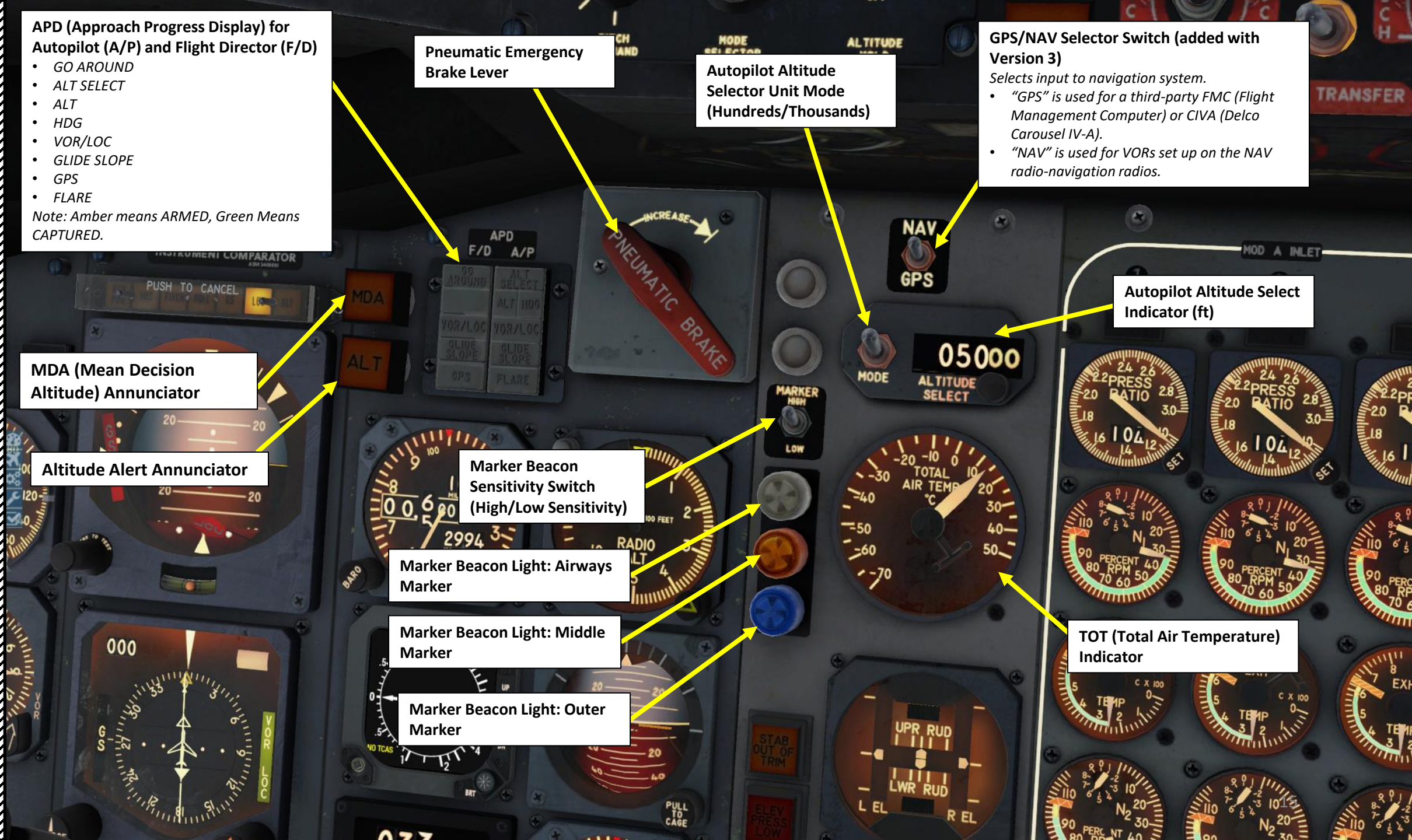

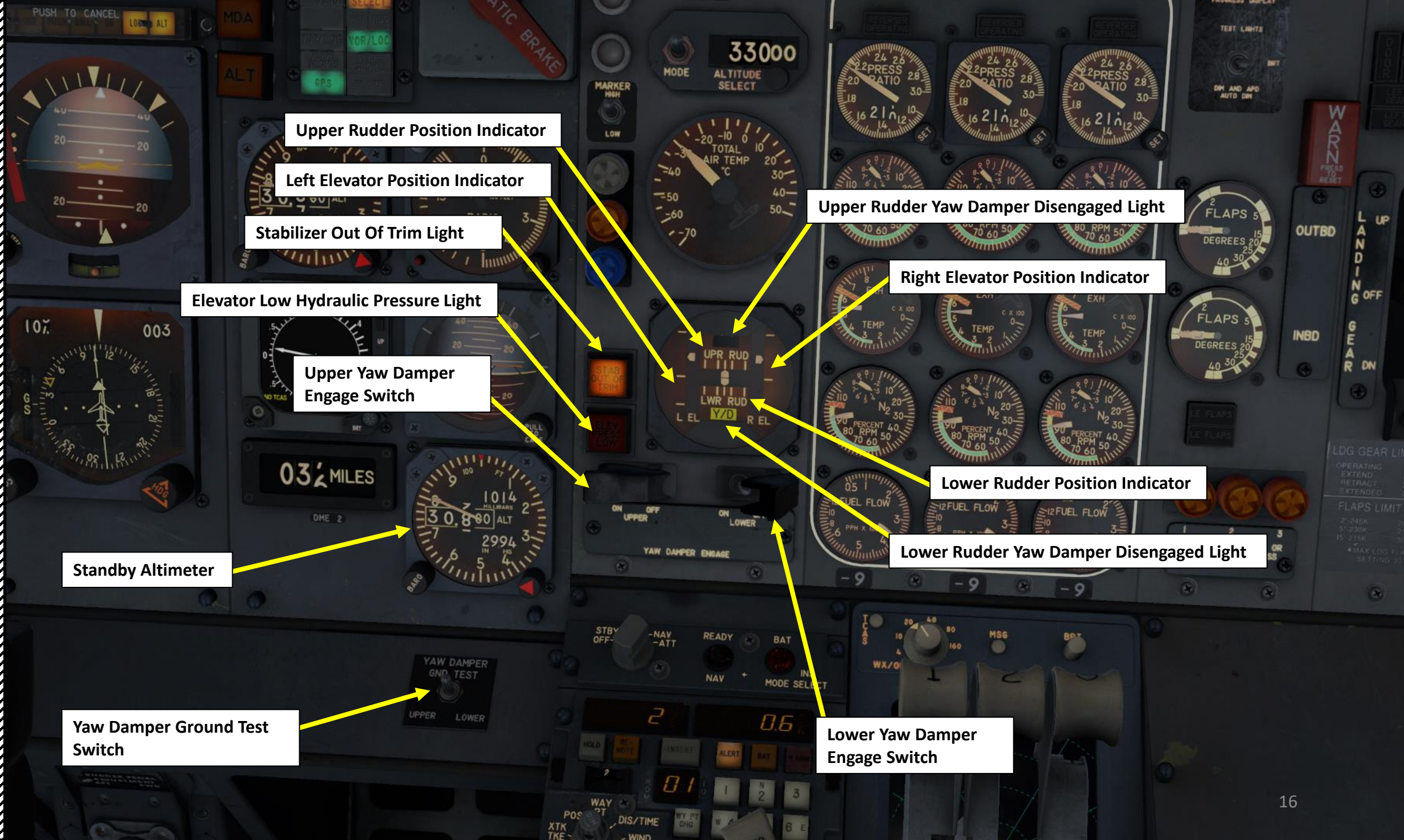

Upper Rudder Position Indicator

Left Elevator Position Indicator

Stabilizer Out Of Trim Light

Elevator Low Hydraulic Pressure Light

Upper Yaw Damper Engage Switch

Standby Altimeter

Yaw Damper Ground Test Switch

Upper Rudder Yaw Damper Disengaged Light

Right Elevator Position Indicator

Lower Rudder Position Indicator

Lower Rudder Yaw Damper Disengaged Light

Lower Yaw Damper Engage Switch

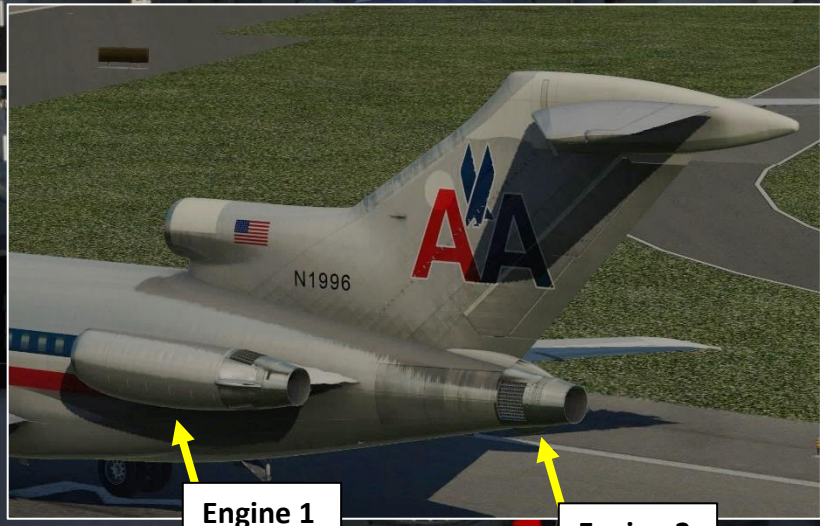
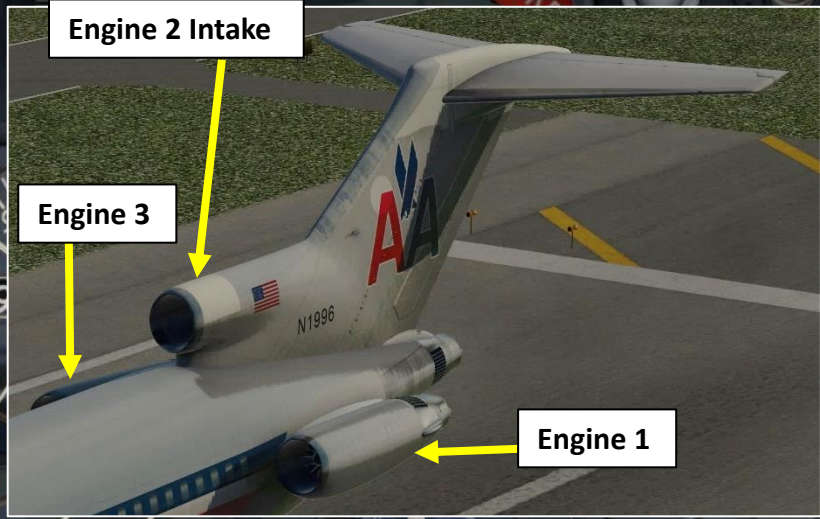

Engine 1 Instruments (Left Engine)

Engine 2 Instruments (Central Engine)

Engine 3 Instruments (Right Engine)

Thrust Reverser Operating Indication Light

Engine Pressure Ratio Reference Bug

Engine Pressure Ratio (used as thrust reference)

Engine Pressure Ratio Reference Bug Setting Knob

Engine N1 Tachometer
Engine fan, low-pressure compressor and low-pressure turbine rotor speed (%)

EXH/EGT (Exhaust Gas Temperature) Indication (x100 deg C)

Engine N2 Tachometer
Engine high-pressure compressor and high-pressure turbine rotor speed (%)

Fuel Flow Indicator (x1000 lbs/hour)

Engine model used. The -9 refers to the JT8D-9A engines. then 727-200 uses the -15 and the freighter has -17.

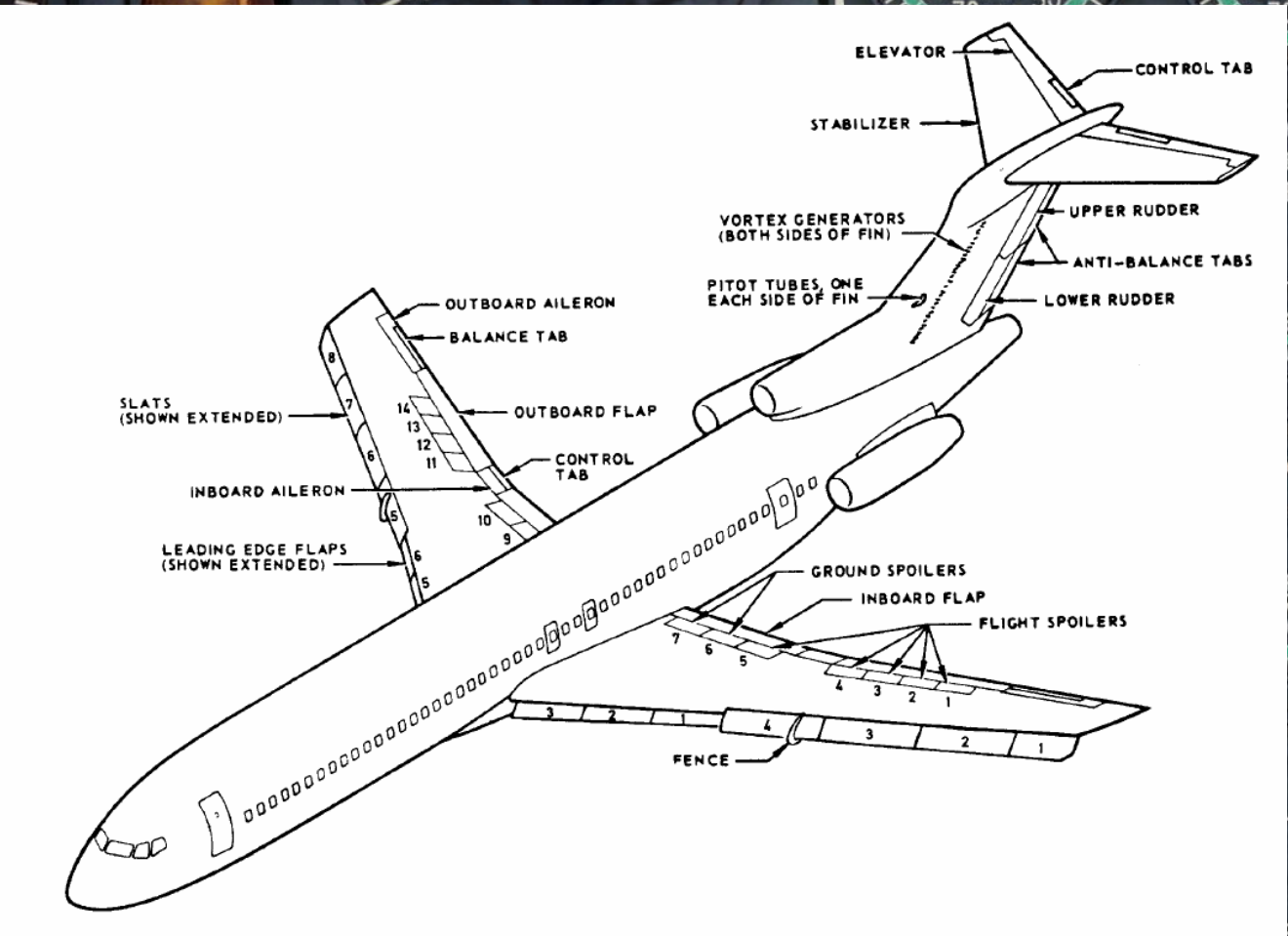

Outboard Flaps Indicator (degrees)

Inboard Flaps Indicator (degrees)

Leading Edge Flaps (Amber)
Extinguished: Retracted
Amber: Flaps In Transition

Leading Edge Flaps (Green)
Extinguished: Retracted
Green: Flaps deployed as per flap setting

Engine Low Oil Pressure Lights (Engines 1, 2, & 3)
Illuminates when engine oil pressure is below 35 psi or oil filter bypass valves are open



**Landing Gear Door Annunciator
(Red when in transition)**

Landing Gear Annunciator
*Green: Down and Locked
Red: In transition or Unsafe*

**Aileron, Rudder and Elevator Low
Hydraulic Pressure Annunciators
(Systems A & B)**
*Illuminated when hydraulic pressure is
below 1200 + 250 psi*

Indicator Lights Test Switch

Master Warning Push-Light

Landing Gear Lever
UP / OFF / DOWN

WARN
PRESS TO RESET

Landing Gear Limits (Indicated Airspeed)
 EXTEND: 270 kts, Mach 0.83
 RETRACT: 200 kts
 EXTENDED: 320 kts, Mach 0.83

LDG GEAR LIMIT (IAS)
 OPERATING 270K-83M
 EXTEND 200K
 RETRACT 320K-83M
 EXTENDED

FLAPS LIMIT (IAS)
 2°-245K 20°-205K
 5°-230K 25°-195K
 15°-215K 30°-185K*
 *MAX LDG FLAP SETTING 30°

Flaps Limits (Indicated Airspeed)
 2 deg - 245 kts
 5 deg - 230 kts
 15 deg - 215 kts
 20 deg - 205 kts
 25 deg - 195 kts
 30 deg - 185 kts

NOTE: MAX LANDING FLAP SETTING: 30 deg

True Airspeed Gauge (kts)



Pneumatic Brake Pressure (x1000 psi)



Hydraulic Brake Pressure (x1000 psi)



Ground Proximity Warning System Flap/Gear Inhibit Switch



Ground Proximity Warning System Test Button

Copilot Instrument Panel





Windshield Air Knob

Foot Air Knob



Audio Selector Panel





Magnetic Compass

Flight Director Mode Selector
 GA: Go-Around
 OFF: Autopilot Off
 HDG: Heading
 NAV/LOC: Navigation/Localizer
 APPR AUTO: Automatic Approach
 APPR MAN: Manual Approach

Engine 1 Fire Detection Light & Fire Extinguisher Handle

Engine 3 Fire Detection Light & Fire Extinguisher Handle

Wheel Well Fire Detection Light

Engine 2 Fire Detection Light & Fire Extinguisher Handle

Fire Detector Bell Cutout Button

Fire Detector Test Switch

Flight Director (Autopilot) Altitude Hold Switch

Flight Director (Autopilot) Pitch Command Knob

Fire Extinguisher Bottle 1 Discharged Light

Fire Extinguisher Bottle Transfer Switch

Fire Extinguisher Bottle 2 Discharged Light



CENTRAL PEDESTAL



CIVA Mode Selector Knob
 OFF
 STBY: Standby Mode
 ALIGN: INS Alignment Mode
 NAV: Navigation Mode
 ATT: Attitude Mode (Emergency)

HOLD Key
 Freezes data displayed in screens

RE-MOTE Key
 Only used for X-Plane Flight Plans

Waypoint Selector Rotary

Waypoint Selected
 0 = CURRENT POSITION

CIVA Data Selector Switch

- **TK/GS:** Ground Track/Ground Speed
- **HDG/DA:** Current heading (relative to true north) / Drift Angle relative to wind
- **XTK/TKE:** Cross Track Error (tenth of nautical mile) / Track Angle Error
- **POS:** Current position coordinates of aircraft
- **WAYPT:** Coordinates of selected waypoint
- **DIS/TIME:** Distance (tenth of nautical mile) and time (minutes) to selected waypoint
- **WIND:** Wind direction (deg relative to true north) and speed (kts)
- **DSRTK/STS:** Desired Track Angle to selected waypoint / Status codes of INS

YAW DAMPER
 GND TEST
 UPPER LOWER

READY NAV Light
 Illuminates in green when unit is aligned and ready for use

BAT INS
 Illuminated when unit has shutdown whilst operating on battery

Delco Carousel IV-A Inertial Navigation System (CIVA INS) Panel

Display Window (Shown: Coordinates)

WARN Warning Light
 Illuminates in red when error is detected

BAT Warning Light
 Illuminates once in ALIGN mode and when the INS is operating on the battery

ALERT Warning Light
 Illuminates 2 minutes before a waypoint is reached and ground speed is over 250 kts

INSERT Key
 General button used to confirm input in display windows

FROM-TO Display
 Shows what leg the aircraft is flying on (shown: between waypoint 0 (current position) and waypoint 1)

WY PT CHG (Waypoint Change) Key
 Allows to either directly navigate to any waypoint or intercept a leg

AUTO/MAN Switch
 Selects either automatic or manual leg switching

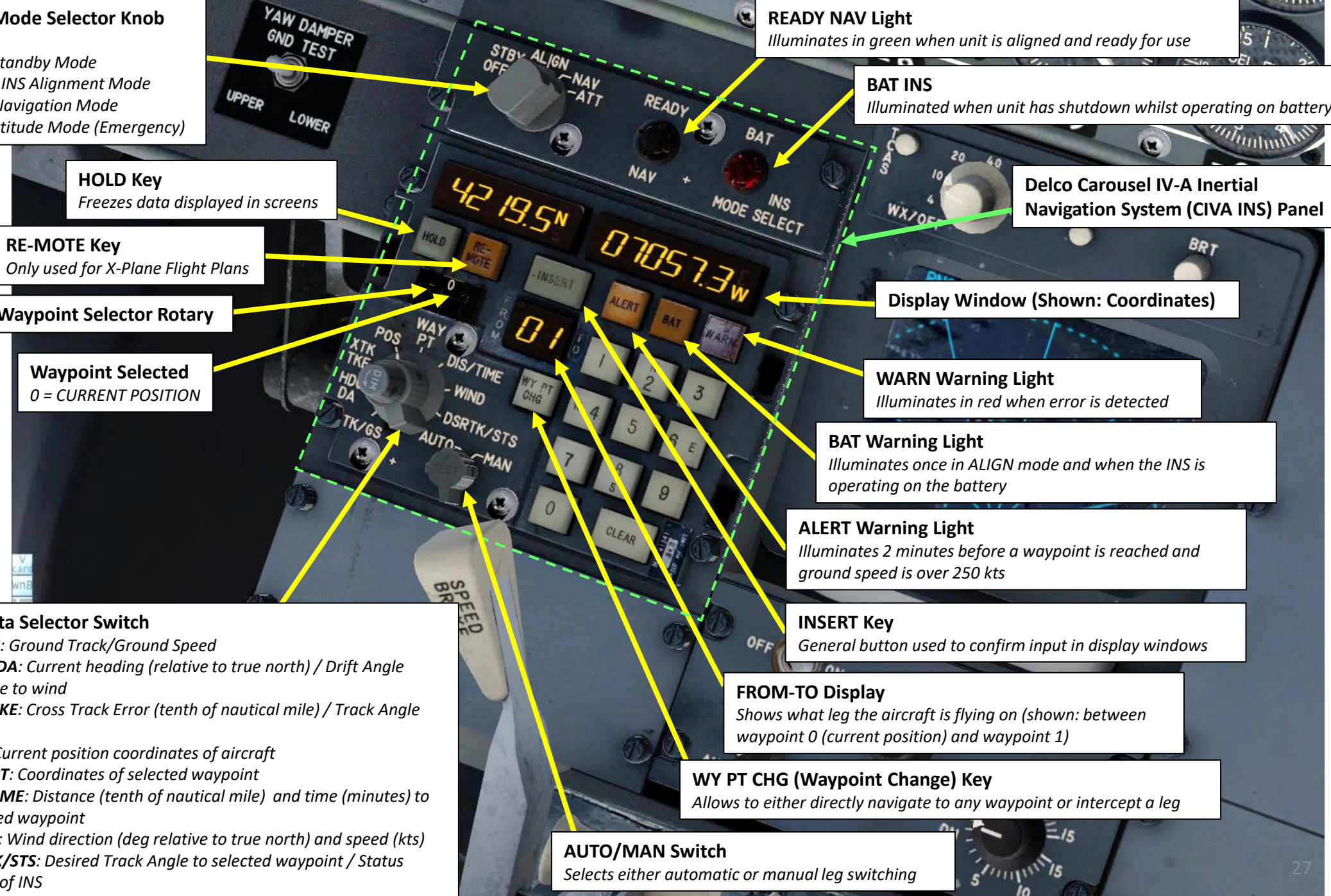

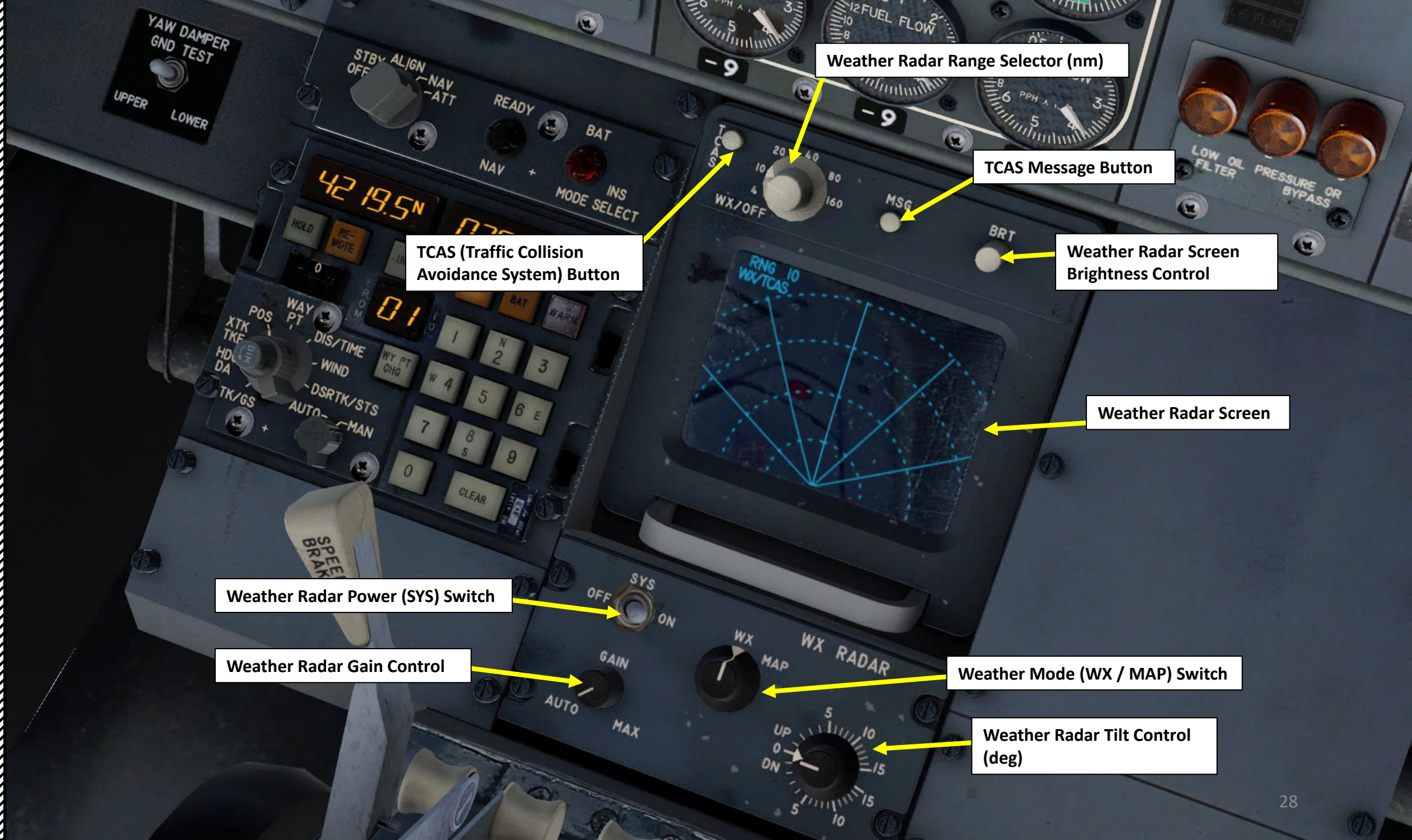

YAW DAMPER
GND TEST
UPPER LOWER

STBY ALIGN OFF
NAV ATT
READY
BAT
NAV +
INS MODE SELECT

42 19.5N

TCAS (Traffic Collision Avoidance System) Button

Weather Radar Range Selector (nm)

TCAS Message Button

Weather Radar Screen Brightness Control

Weather Radar Screen

Weather Radar Power (SYS) Switch

Weather Radar Gain Control

Weather Mode (WX / MAP) Switch

Weather Radar Tilt Control (deg)

WAY PT DIS/TIME WY PT CHG WIND DSRTK/STS AUTO-MAN
TK/GS
TKF HDL DA
XTK POS
TK/DA
WAY PT DIS/TIME WY PT CHG WIND DSRTK/STS AUTO-MAN
TK/GS
TKF HDL DA
XTK POS
TK/DA

SYS OFF ON

GAIN AUTO MAX

WX MAP WX RADAR

UP 5 10 15 20 25 30 35 40 45 50 55 60 65 70 75 80 85 90 95 100
DN 5 10 15 20 25 30 35 40 45 50 55 60 65 70 75 80 85 90 95 100

LOW OIL FILTER PRESSURE OR BYPASS

Speed Brake Switch ("Spoiler")
FWD: Retracted
AFT: Deployed

Thrust Reverser Lever
Can only be deployed if throttle is at IDLE.

Flap Lever
Left clicking and dragging it AFT (deploys flaps), while right clicking and dragging it moves it FORWARD (retracts flaps)

Throttles

Engine Start Levers
UP: IDLE (opens fuel shutoff valve and energizes ignition system)
DOWN: CUTOFF (closes fuel shutoff valve and de-energizes ignition system)

Stabilizer Trim Wheel

Stabilizer Trim Indicator

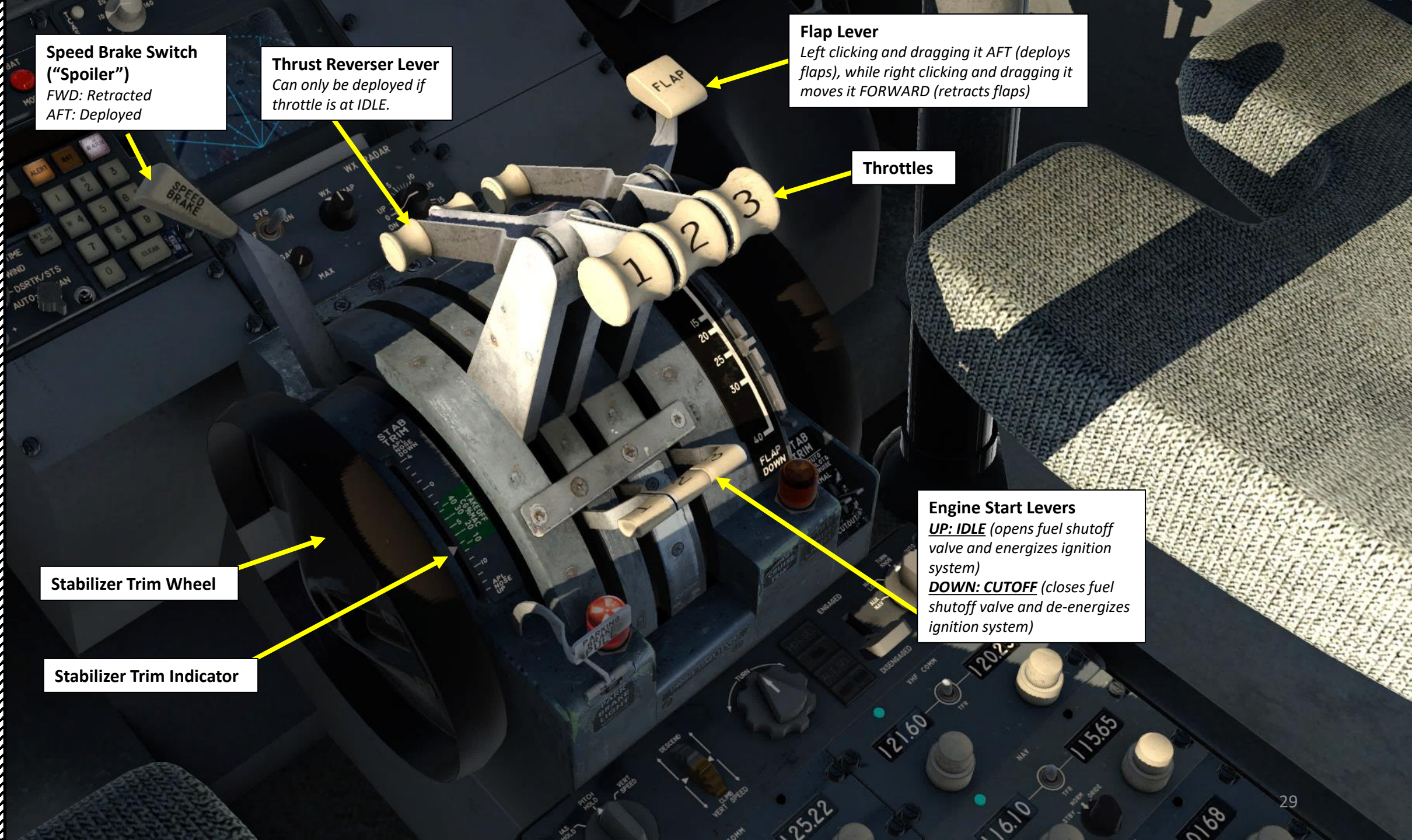

PART 2 - COCKPIT LAYOUT

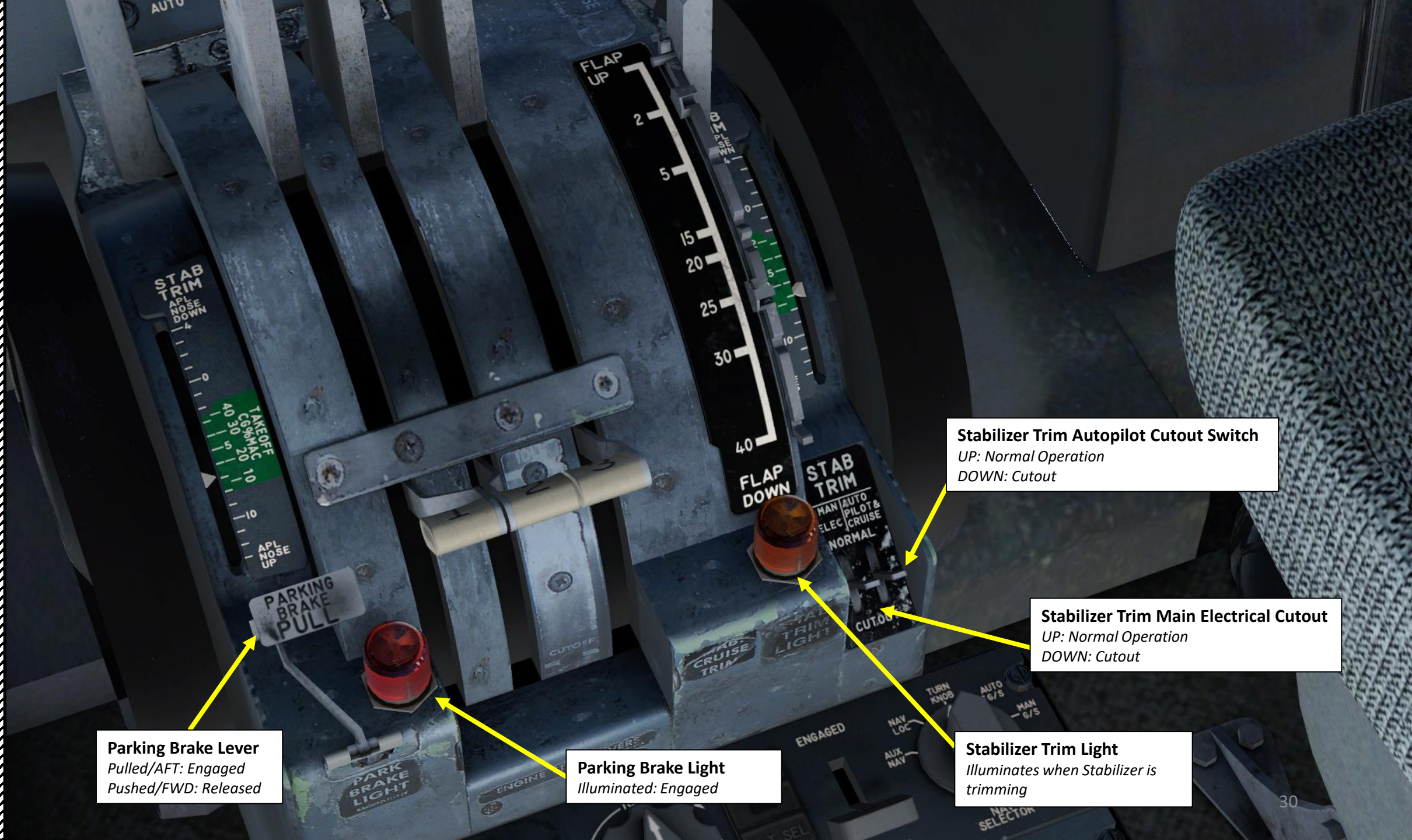

Parking Brake Lever
Pulled/AFT: Engaged
Pushed/FWD: Released

Parking Brake Light
Illuminated: Engaged

Stabilizer Trim Autopilot Cutout Switch
UP: Normal Operation
DOWN: Cutout

Stabilizer Trim Main Electrical Cutout
UP: Normal Operation
DOWN: Cutout

Stabilizer Trim Light
Illuminates when Stabilizer is trimming

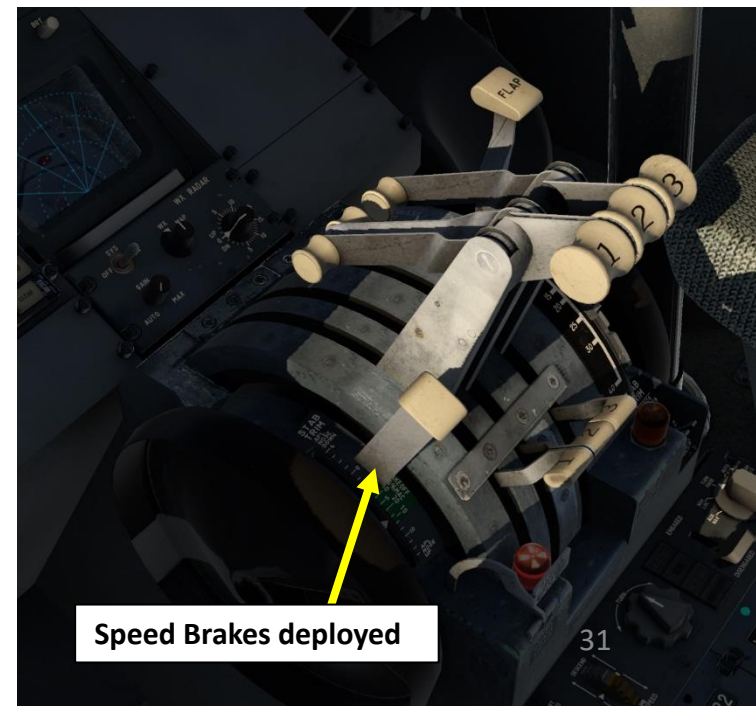
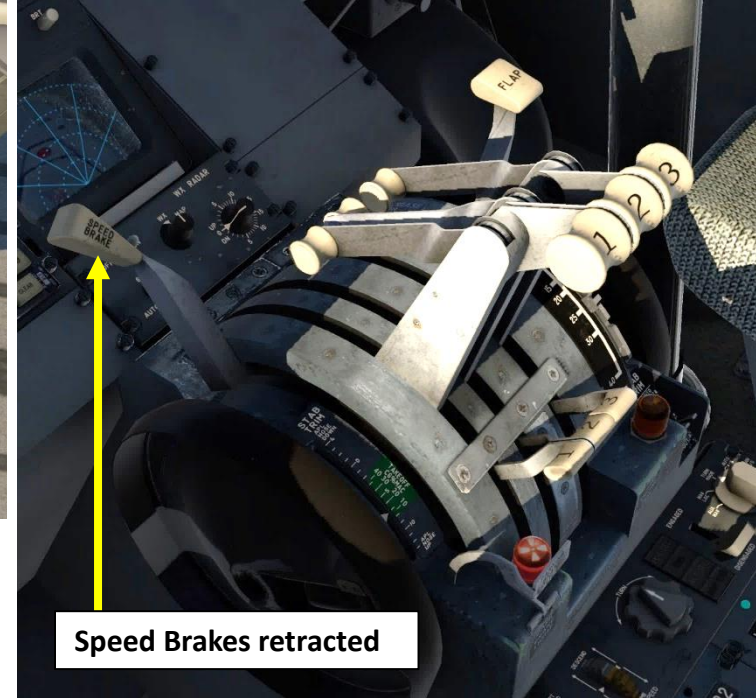
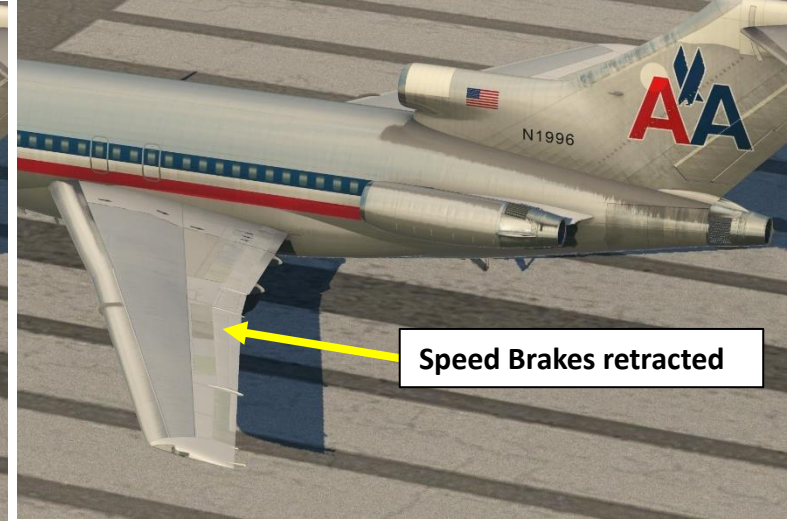
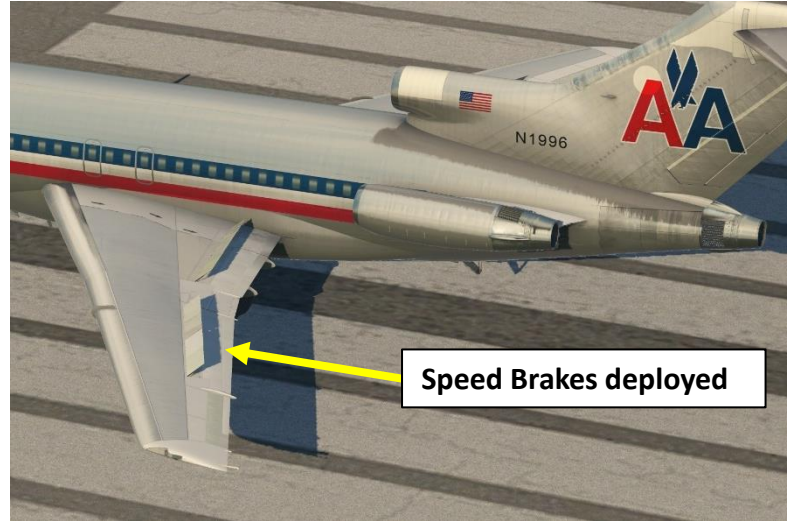

General Sound Graphics Network Data Output **Joystick** Keyboard GPS Hardware VR Hardware

Device: HOTAS Warthog Throttle Calibrate View: Throttle Front

SPEEDBRAKES EXTEND FULL and SPEEDBRAKES RETRACT FULL control bindings

- 12 Fuel Flow L
Override: Do nothing. Edit
Normal: Fuel pump for engine #2 on. Edit
- 13 Fuel Flow R
Normal: Fuel pump for engine #1 on. Edit
Override: Do nothing. Edit
- 14 Red thumb btn
back: Do nothing. Edit
forward: Do nothing. Edit
- 15 Gray rocker
back: Do nothing. Edit
forward: Do nothing. Edit
center: Do nothing. Edit
- 16 Gray slider
back: Speedbrakes extend full. Edit
forward: Speedbrakes retract full. Edit
- 17 Thumb Hat Switch Press: Do nothing. Edit
- 18 L/G Wm: Landing gear emergency override off. Edit
- 19 Autopilot Toggle: Do nothing. Edit
- 20 R Throttle Cut-Off: Do nothing. Edit
- 21 L Throttle Cut-Off: Do nothing. Edit

Reset to Defaults for HOTAS Warthog Throttle

Active Profile User Profile Manage Profiles Control Sensitivity PFC Hardware Done

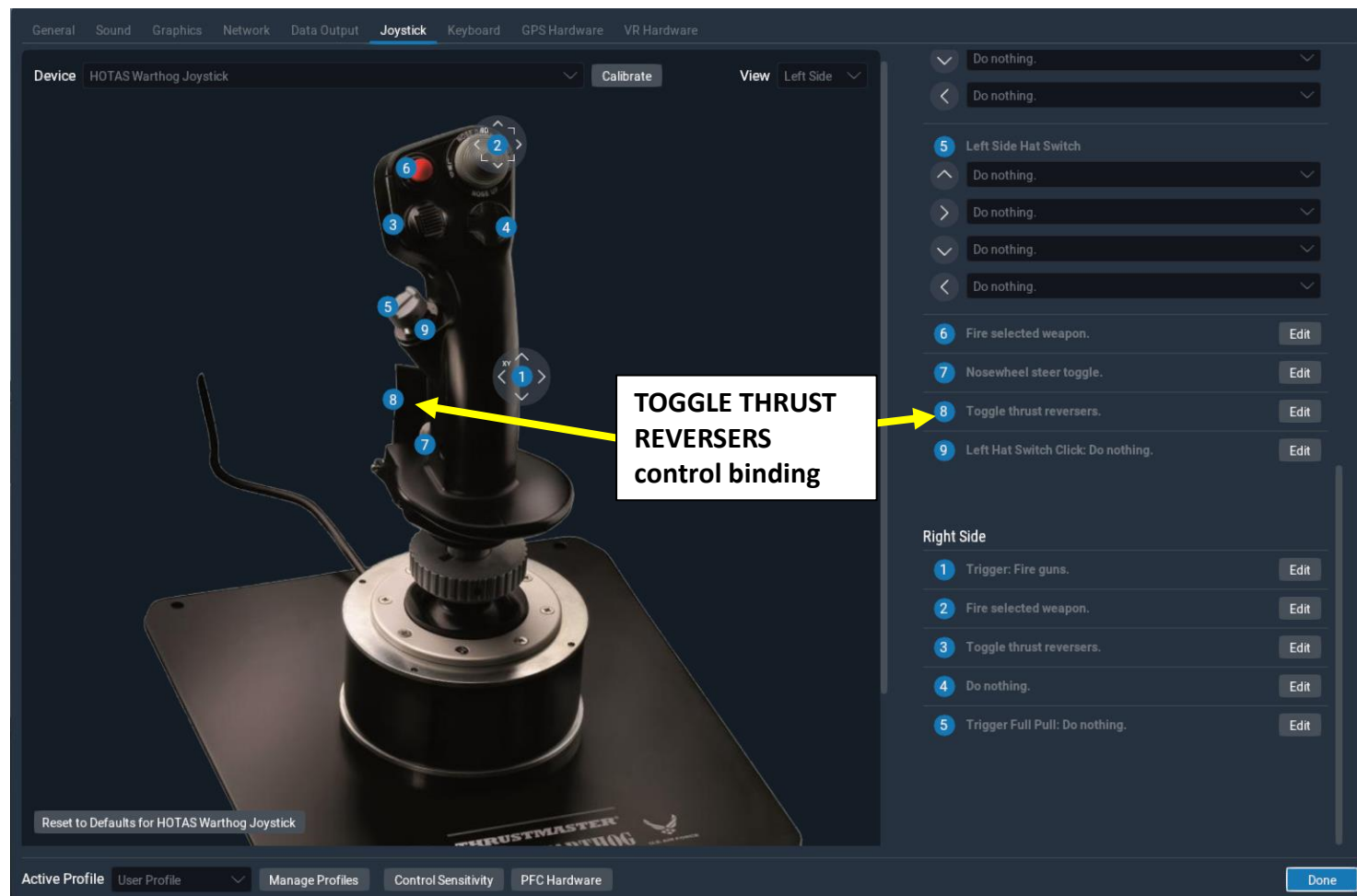
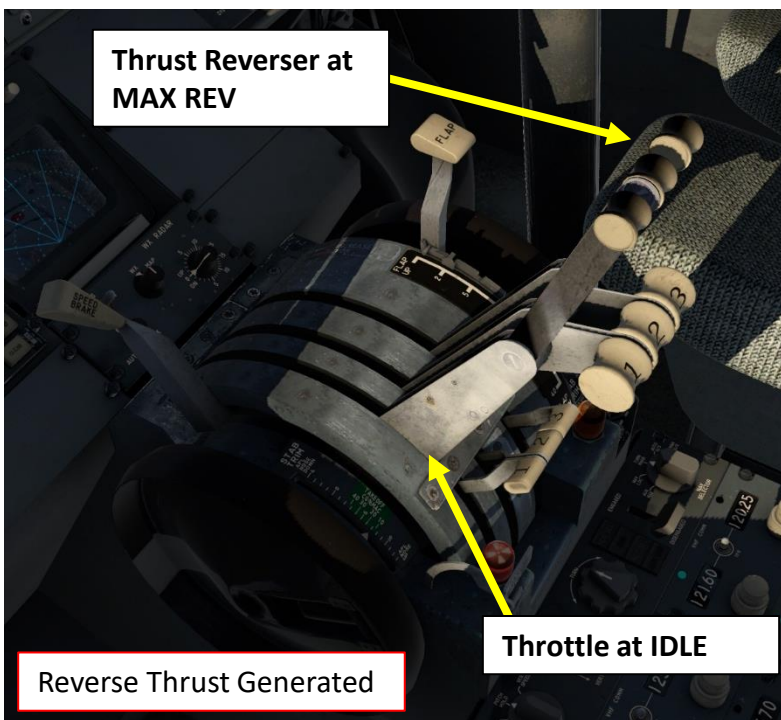
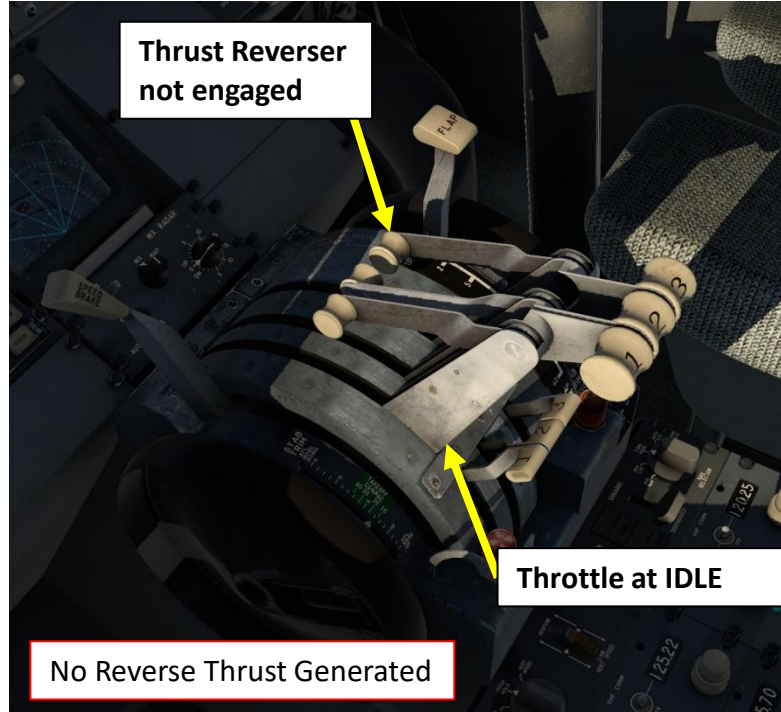

The Thrust Reverser lever can be moved by setting the throttle at IDLE first, then pressing the “TOGGLE THRUST REVERSERS” binding. This will then link your throttle axis to the thrust reverser lever axis. Moving your throttle forward will then move the thrust reverser lever AFT, engaging internal clam-shell thrust reversers to MAX REV. To disengage thrust reversers, set your throttle back to IDLE and press the “TOGGLE THRUST REVERSERS” binding again. This will set your throttle axis back to the way it was.

Take note that the Reverse Thrust lever can only be engaged if your throttle is at IDLE. The reason for that is a mechanical stopper that prevents you from engaging thrust reversers at high throttle settings.

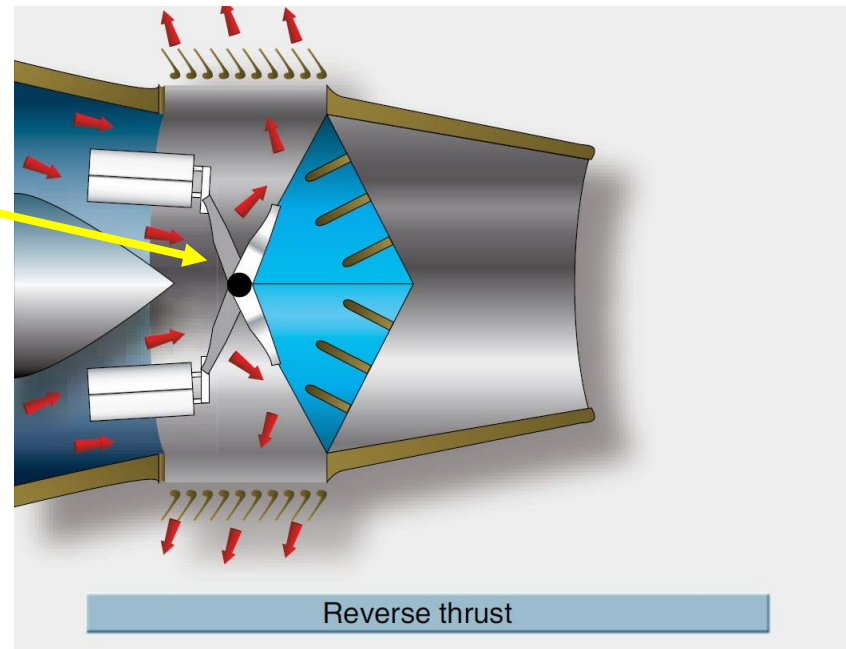
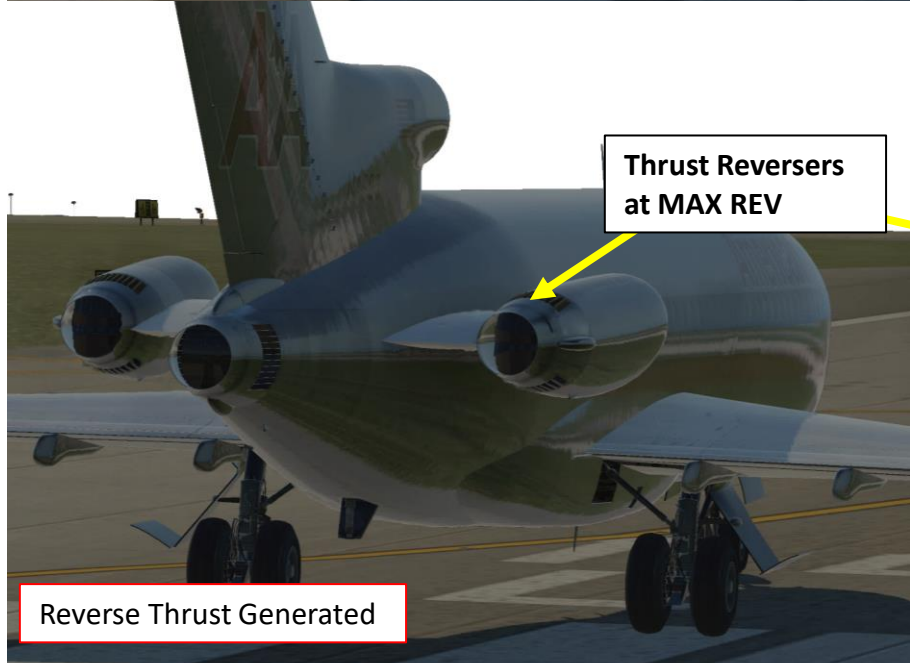
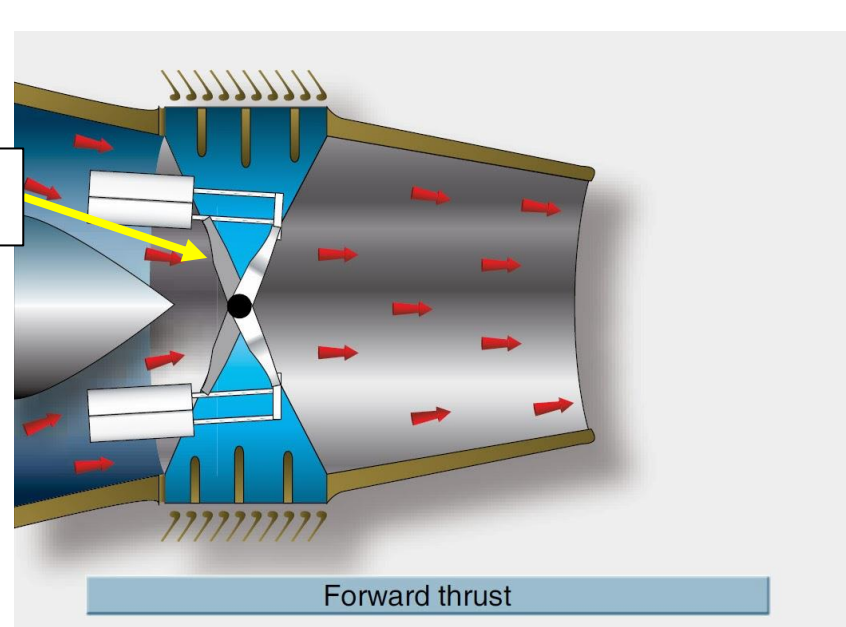
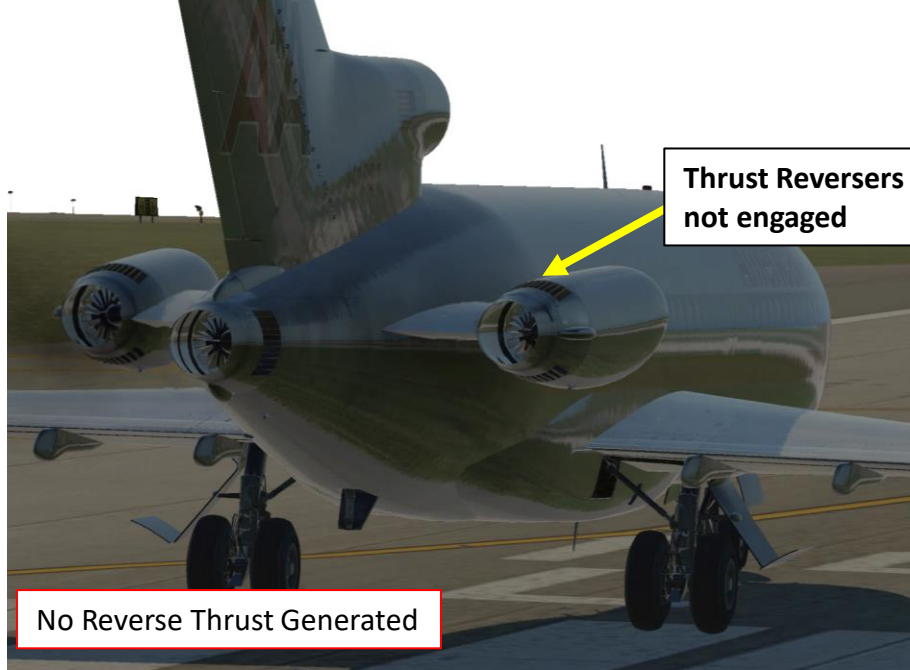

The thrust reverser type incorporated with the Pratt & Whitney JT8D-9A engines is an internal clam-shell design. This explains why there are no external clamshell doors being deployed like in the more modern JT8D-200 engines of aircraft like the McDonnell Douglas MD-80.

Autopilot Pitch Selector

- *MACH HOLD*: Aircraft pitch varies to maintain a constant Mach number
- *IAS HOLD*: Aircraft pitch varies to maintain a constant Indicated Airspeed
- *PITCH HOLD*: Aircraft varies airspeed to maintain a constant pitch
- *VERT SPEED*: Aircraft varies airspeed and pitch to maintain a constant vertical speed (climb/descent rate)

Autopilot Heading Selector Button

Autopilot ENG (Engaged) Light

Autopilot Engage Switch

Autopilot Roll (Turn) Selector

Sperry SP-50 Autopilot Navigation (Mode) Selector

- *AUX NAV*: Auxiliary Navigation (CIVA, X-FMC)
- *NAV LOC*: Navigation Localizer
- *TURN KNOB*: Autopilot Roll/Turn Selector Mode
- *AUTO G/S*: Automatic Glide Slope
- *MAN G/S*: Manual Glide Slope

Autopilot Altitude Selector Button

Autopilot Altitude Select Mode ARM Light (Armed)

Autopilot Altitude Select Mode ENG Light (Engaged)

Autopilot Vertical Speed Selector

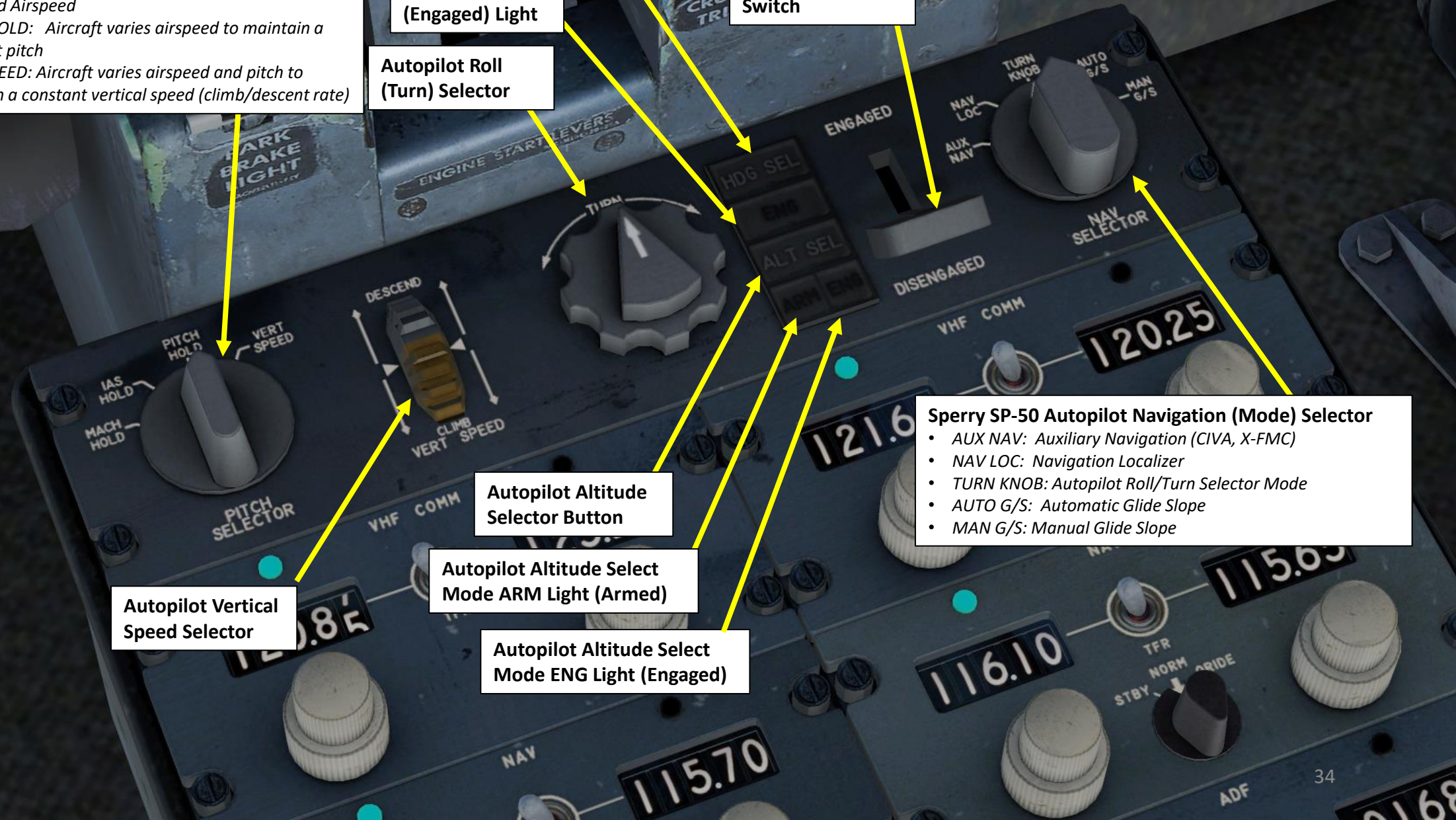

VHF Frequency 2

VHF COMM 2 Radio Set Panel

VHF Frequency 2
Tuning Knob

VHF COMM 1 Radio Set Panel

TFR (Transfer) Active
Frequency Switch

Active Frequency Light

VHF Frequency 1

VHF Frequency 1
Tuning Knob

VHF-1 Radio Navigation
Panel

ADF-1 Radio Navigation
Panel

VHF-2 Radio Navigation
Panel

ADF-2 Radio Navigation
Panel

VHF Navigation Mode Knob
STBY: Standby
NORM: Normal
ORIDE: Override

ADF Navigation Mode Knob
STBY: Standby
NORM: Normal
ORIDE: Override

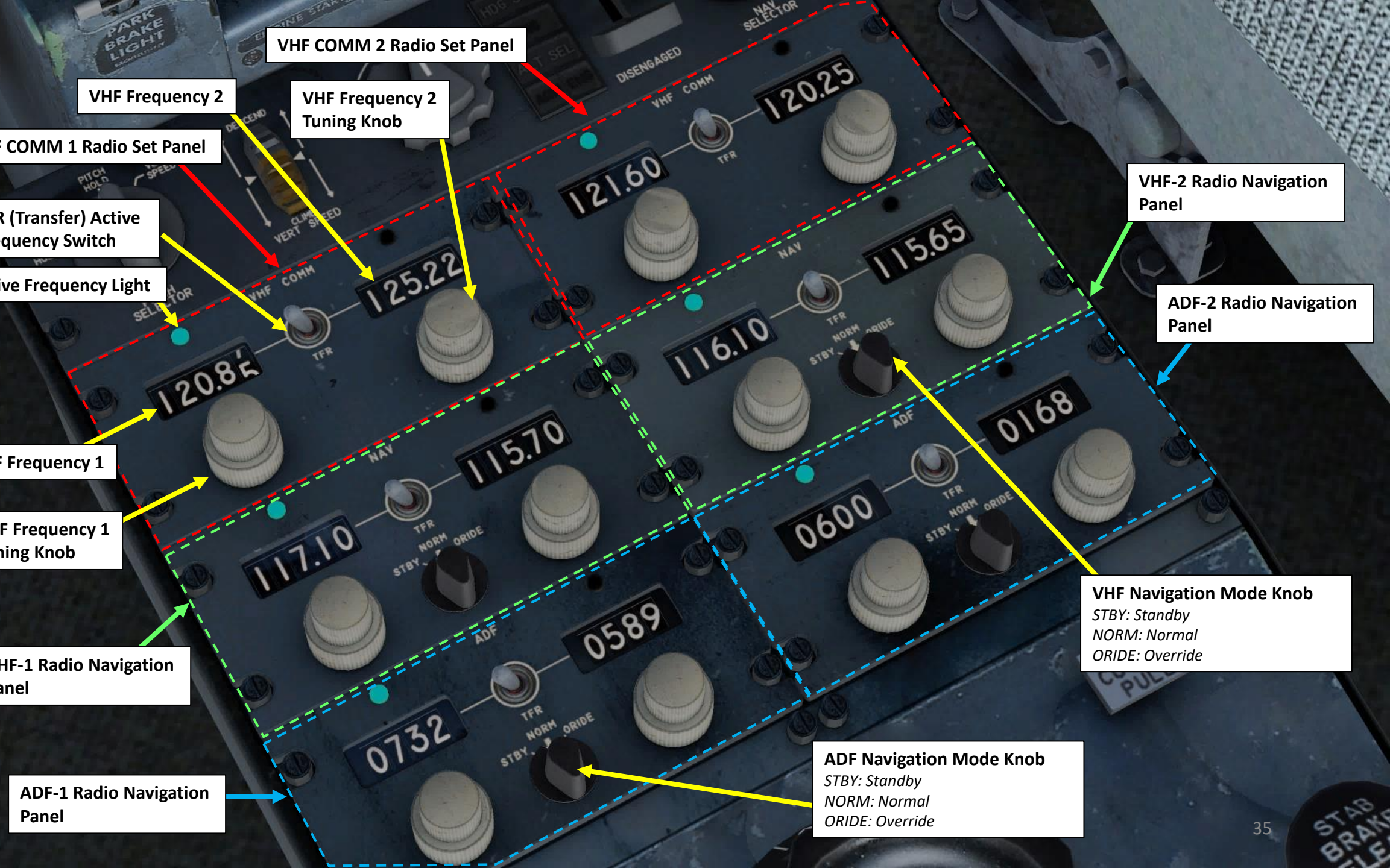



Radio Panels and Autopilot Panel Lighting Control Knob

Rudder Trim Knob

Horn Cutout Switch

Stabilizer Brake Release Lever

Aileron Trim Knob

OVERHEAD PANEL



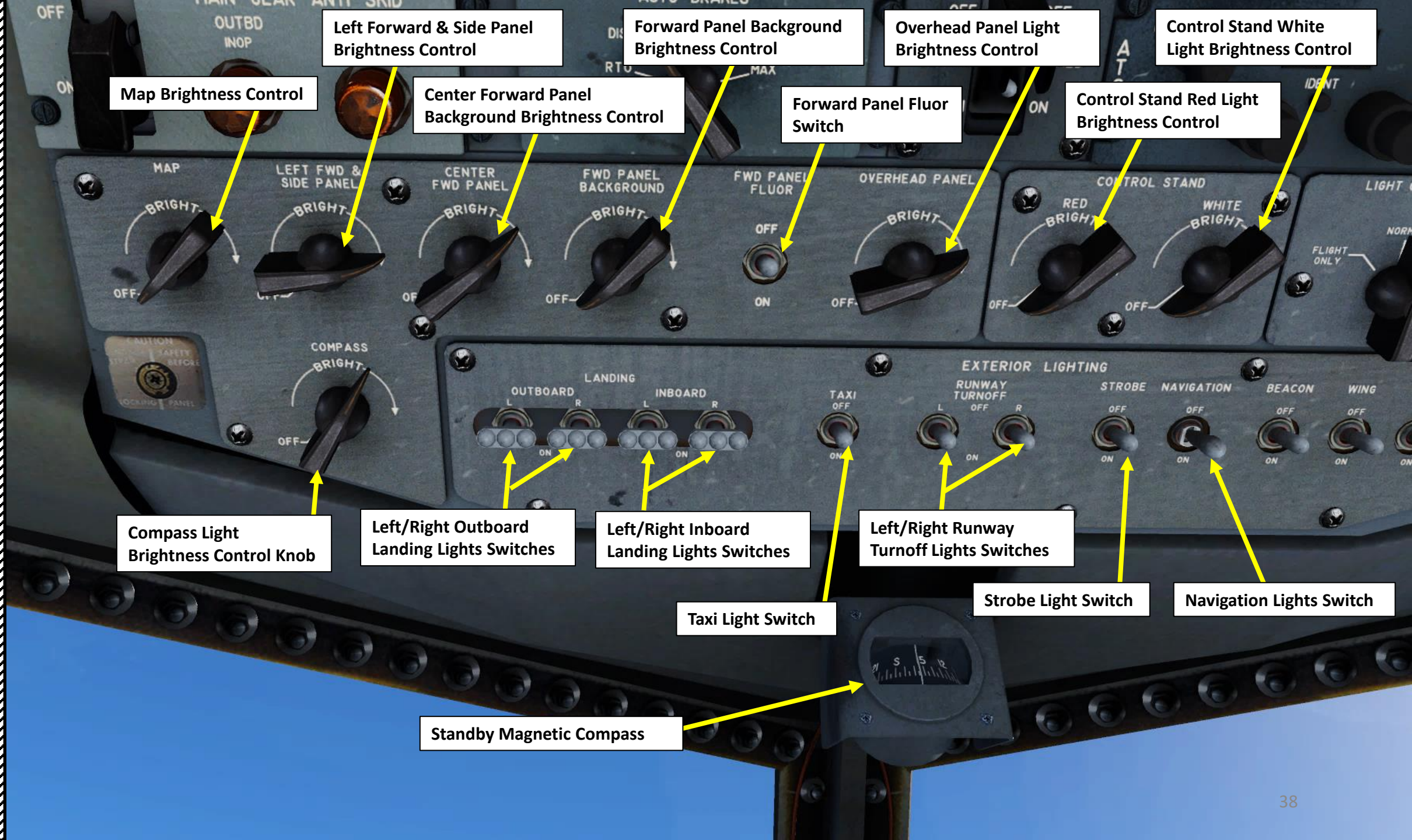

Map Brightness Control

Left Forward & Side Panel Brightness Control

Center Forward Panel Background Brightness Control

Forward Panel Background Brightness Control

Forward Panel Fluor Switch

Overhead Panel Light Brightness Control

Control Stand Red Light Brightness Control

Control Stand White Light Brightness Control

Compass Light Brightness Control Knob

Left/Right Outboard Landing Lights Switches

Left/Right Inboard Landing Lights Switches

Left/Right Runway Turnoff Lights Switches

Taxi Light Switch

Strobe Light Switch

Navigation Lights Switch

Standby Magnetic Compass

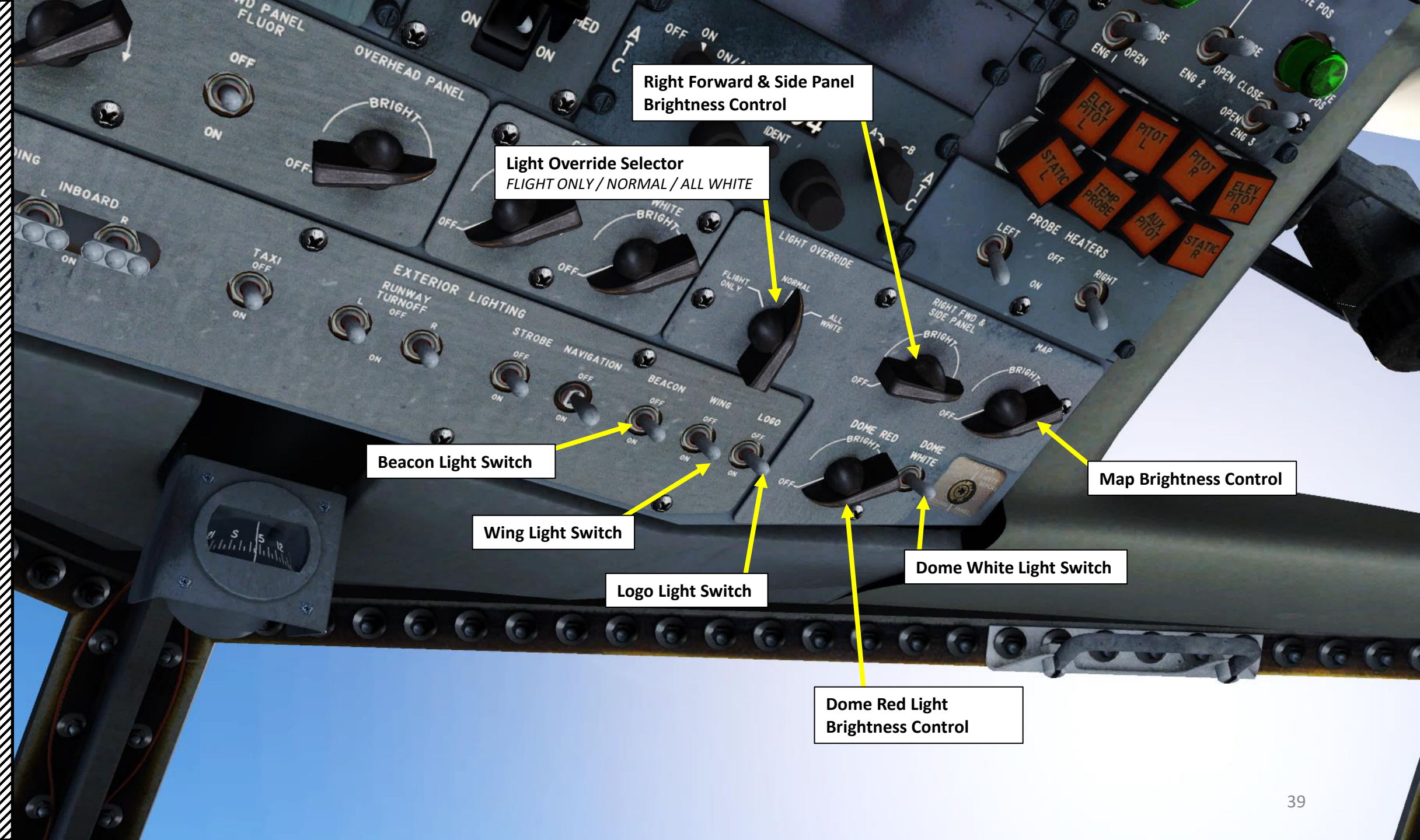

Right Forward & Side Panel
Brightness Control

Light Override Selector
FLIGHT ONLY / NORMAL / ALL WHITE

Beacon Light Switch

Wing Light Switch

Logo Light Switch

Dome White Light Switch

Dome Red Light
Brightness Control

Map Brightness Control



VHF Navigation Source Selector

Compass Source Selector

Flight Control Warning Test Switch

Cargo Fire Detection Loop Selector (Aft Bay)

Vertical Gyro Source Selector

Fire Detection Fault Light

Cargo Fire Extinguisher Bottle Test Light (Forward/Aft Bay)

Anti-Skid Master Switch

Cargo Fire Detection Loop Selector (Forward Bay)

Emergency Exit Lights Unarmed Light

Cargo Fire Detection Test Button

Main Landing Gear Anti-Skid Inoperative (Outboard)

Main Landing Gear Anti-Skid Inoperative (Inboard)

Auto-Brake Selector Switch
RTO: Rejected Takeoff
DISARM: Disarmed
MIN: Minimum Braking
MED: Medium Braking
MAX: Maximum Braking

Cargo Fire Extinguisher Bottle Discharge Button

Cargo Fire Extinguisher Bottle Arming Switch (Forward/Aft Bay)

Emergency Exit Lights Switch

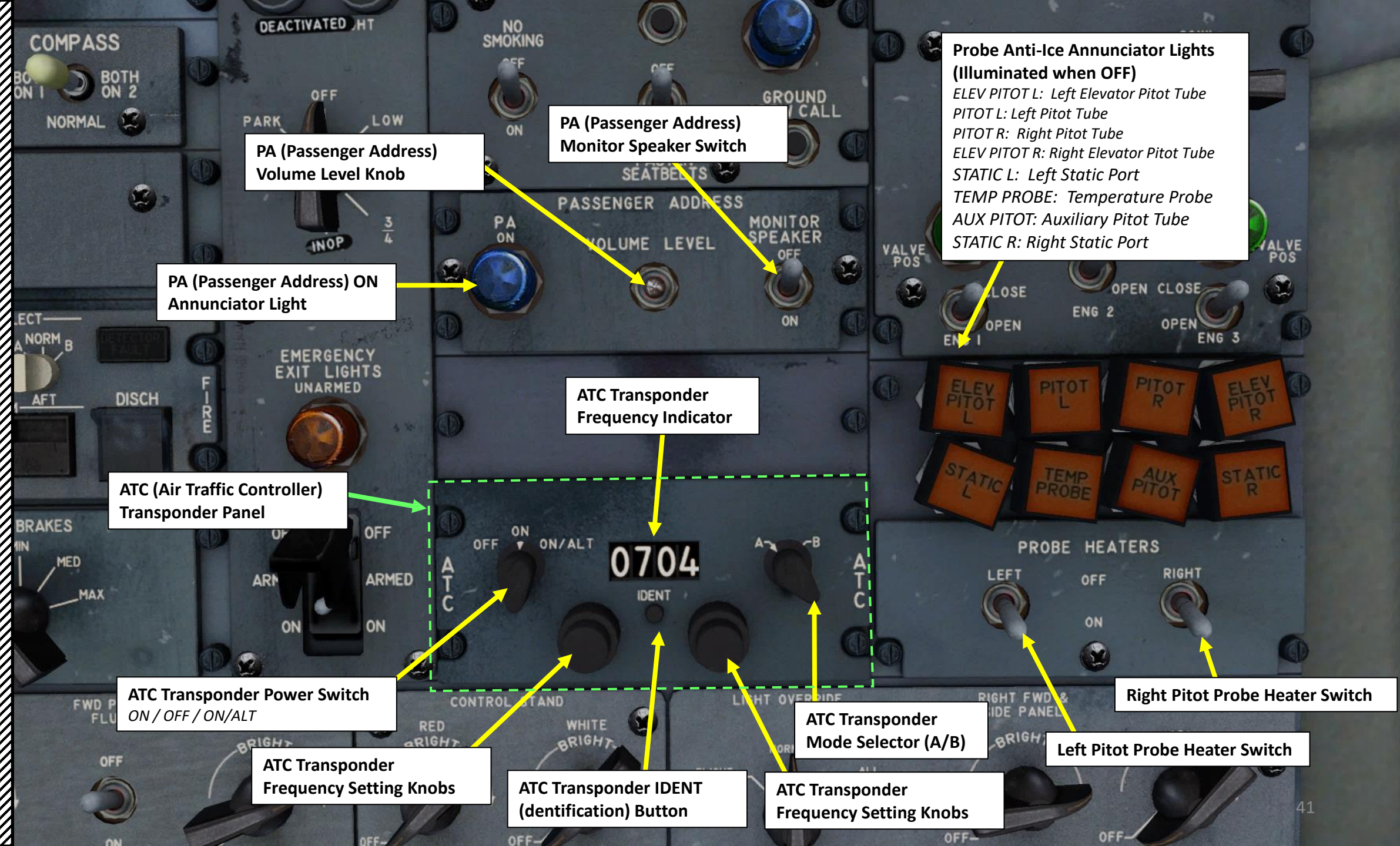

**Probe Anti-Ice Annunciator Lights
(Illuminated when OFF)**
 ELEV PITOT L: Left Elevator Pitot Tube
 PITOT L: Left Pitot Tube
 PITOT R: Right Pitot Tube
 ELEV PITOT R: Right Elevator Pitot Tube
 STATIC L: Left Static Port
 TEMP PROBE: Temperature Probe
 AUX PITOT: Auxiliary Pitot Tube
 STATIC R: Right Static Port

PA (Passenger Address)
Volume Level Knob

PA (Passenger Address)
Monitor Speaker Switch

PA (Passenger Address) ON
Annunciator Light

ATC Transponder
Frequency Indicator

ATC (Air Traffic Controller)
Transponder Panel

ELEV PITOT L
PITOT L
PITOT R
ELEV PITOT R
STATIC L
TEMP PROBE
AUX PITOT
STATIC R

ATC Transponder Power Switch
ON / OFF / ON / ALT

Right Pitot Probe Heater Switch

ATC Transponder
Frequency Setting Knobs

ATC Transponder IDENT
(identification) Button

ATC Transponder
Frequency Setting Knobs

Left Pitot Probe Heater Switch



RUDDER
SYS A SYS B
OFF
ON

Compass Set Heading Control

COMPASS
FREE
SLAVED SET HDG

Compass Synchronization Indicator

Compass Free/Slaved Switch

Rain Repellant Switch

RAIN REPELLANT
DEACTIVATED HT

Rain Repellant Switch

VHF NAV COMPASS
BOTH ON 1 BOTH ON 2 BOTH ON 1 BOTH ON 2
NORMAL NORMAL

OFF
PARK LOW
1/2
3/4
WIPER

Windshield Wiper Switch

FLT CONTROL WARNING TEST
SAFETY RELAY BYPASS SPARE

VERTICAL GYRO
BOTH ON 1 BOTH ON 2
NORMAL

ANTI SKID

EXT DET SELECT
FWD AFT A NORM B A NORM B

EMERGENCY EXIT LIGHTS

Compass Set Heading Control

Compass Free/Slaved Switch

Compass Synchronization Indicator

Left Wing Anti-ice Bleed Air Valve Switch & Valve Position Light (Illuminated = OPEN)

Right Wing Anti-ice Bleed Air Valve Switch & Valve Position Light (Illuminated = OPEN)

Microphone Monitor Panel



Flight Attendance Call Intercom Button

No Smoking Sign Switch

Fasten Seatbelts Sign Switch

Ground Crew Call Active Light

Ground Crew Call Intercom Button

Anti-Ice Valve Position Light Selector
Selects valves to be checked by the valve position lights (OFF/LEFT/COWL/RIGHT/WING)

Engine 2 Inlet Anti-ice Bleed Air Valve Switch & Valve Position Light (Illuminated = OPEN)

Engine 3 Inlet Anti-ice Bleed Air Valve Switch & Valve Position Light (Illuminated = OPEN)

Engine 1 Inlet Anti-ice Bleed Air Valve Switch & Valve Position Light (Illuminated = OPEN)

HYDRAULIC POWER

AILERON SYS A SYS B

SPOILER SYS A SYS B INBD OUTBD

OFF ON

Aileron Hydraulic System (A & B) Switches

ELEVATOR SYS A SYS B

OFF ON

Elevator Hydraulic System (A & B) Switches

RUDDER SYS A SYS B

OFF ON

Rudder Standby Hydraulic System Switch

Upper Rudder Hydraulic System (A) Switch

Lower Rudder Hydraulic System (B) Switch

STALL WARNING

HTR OFF

TEST

OFF

Stall Warning OFF Light
Indicates sensor heater failure or system failure

Stall Warning Test Indicator
Rotates during test to indicator reliable inputs

Stall Warning Switch

- HTR OFF* : Disables heater for maintenance
- NORMAL*: System is powered when landing gear sensor is in the air position
- TEST*: Stall Warning Test

FLIGHT RECORDER

TEST

OFF

Inboard & Outboard Spoiler Hydraulic System (A & B) Switches

Flight Recorder Test Switch

Flight Recorder OFF Light

ALTERNATE FLAPS

COMPASS FREE

SLAVE SET

RAIN REPELLENT

DEACTIVATED HT

TEST ERASE

HEADSET MICROPHONE MONITOR

NO SMOKING

Red & White Flood Lights



Alternates Flaps Master Switch

Inboard Alternates Flaps Switch

- UP: Retracts trailing edge flaps only
- OFF: Spring-loaded to OFF
- DN: Down, extends trailing edge flaps, leading edge flaps and slats using standby hydraulic system

Outboard Alternates Flaps Switch

- UP: Retracts trailing edge flaps only
- OFF: Spring-loaded to OFF
- DN: Down, extends trailing edge flaps, leading edge flaps and slats using standby hydraulic system

Anti-Ice System Duct Overheat Light

Anti-Ice System Duct Temperature Indicator (deg C)

Anti-Ice System Duct Temperature Selector (Engine 1, 2 & 3)

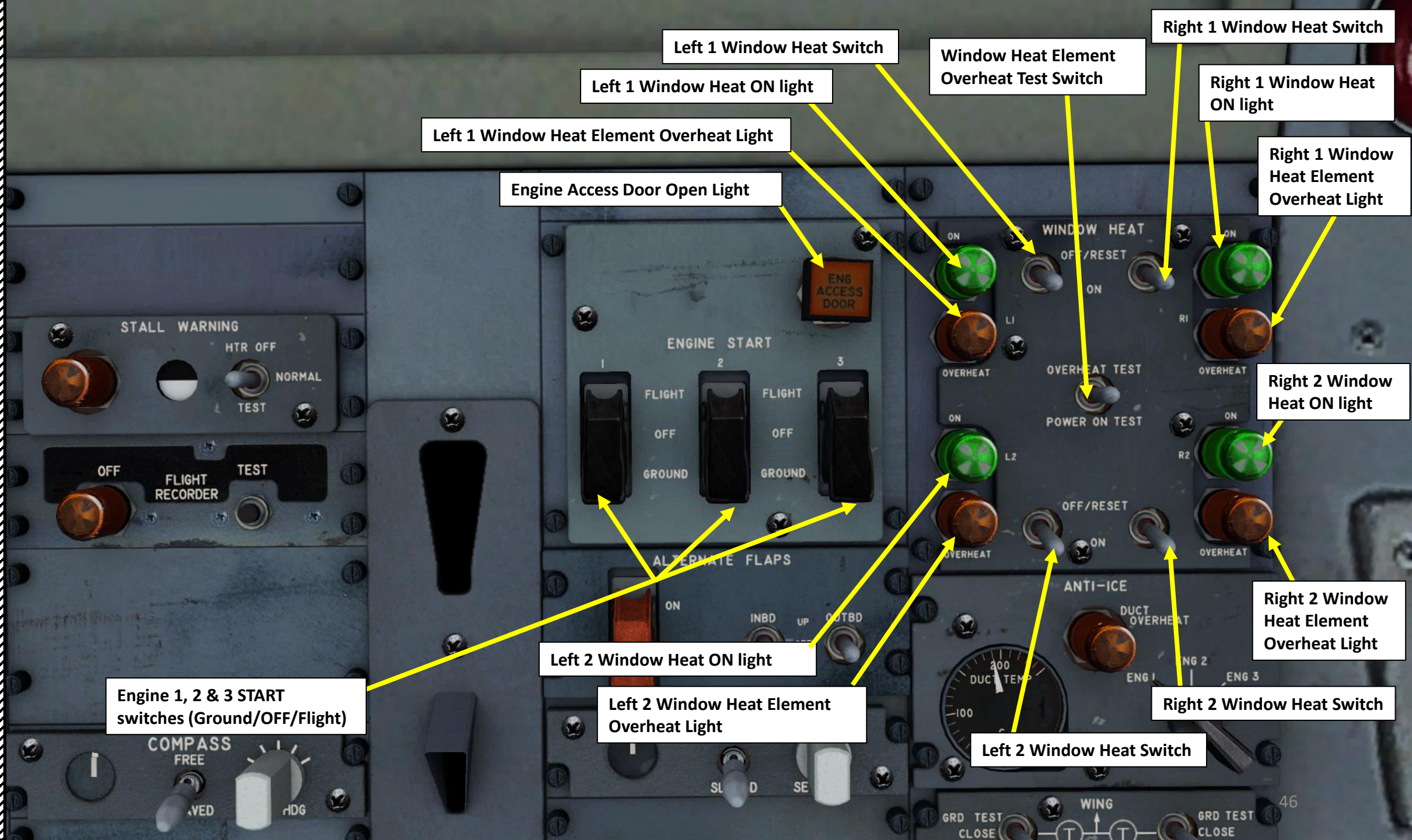

Left 1 Window Heat Switch

Left 1 Window Heat ON light

Window Heat Element Overheat Test Switch

Right 1 Window Heat Switch

Right 1 Window Heat ON light

Left 1 Window Heat Element Overheat Light

Right 1 Window Heat Element Overheat Light

Engine Access Door Open Light

ENG ACCESS DOOR

ENGINE START
1 2 3
FLIGHT OFF FLIGHT OFF FLIGHT OFF
GROUND GROUND GROUND

WINDOW HEAT
ON OFF/RESET ON
LI OVERHEAT OVERHEAT TEST
ON OVERHEAT POWER ON TEST
L2

ON
RI OVERHEAT OVERHEAT
ON
R2

Right 2 Window Heat ON light

STALL WARNING
HTR OFF NORMAL
TEST

OFF FLIGHT RECORDER TEST

ALTERNATE FLAPS

Left 2 Window Heat ON light

Left 2 Window Heat Element Overheat Light

ANTI-ICE
OFF/RESET ON
DUCT OVERHEAT
200
100
DUC TEMP

Right 2 Window Heat Element Overheat Light

Engine 1, 2 & 3 START switches (Ground/OFF/Flight)

Right 2 Window Heat Switch

Left 2 Window Heat Switch

COMPASS
FREE
AVED HDG

GRD TEST CLOSE WING GRD TEST CLOSE

Flight Engineer (FE) Panel



Fuel Dumping System Panel



APU (Auxiliary Power Unit) Panel



LOWER FE PANEL

Engine 1 Fuel Icing Light
Illuminated when fuel filter is clogged by ice

VHF-1 VHF-2 VHF-3 SERV INT INT

PA OFF VOICE BOTH RANGE

NAV-1 DME-1 ADF-1 ADF-2 DME-2 NAV-2

Audio Selector Panel

FUEL HEAT

ENG 1 ICING VALVE IN TRANSIT

ENG 2 ICING VALVE IN TRANSIT

ENG 3 VALVE IN TRANSIT

Engine 1, 2 & 3 Fuel Heat Switches

Engine 1 Fuel Heat Valve IN TRANSIT light
Illuminated when fuel heat valve is in transit, and extinguished when valve is fully open or closed.



Fuel Temperature Indicator – Fuel Tank No. 1 (deg C)

HYDRAULIC SYSTEM A

ENG 1 PUMP ENG 2 PUMP

LOW PRESS ON OFF

ENG 1 ICING VALVE IN TRANSIT

ENG 2 ICING VALVE IN TRANSIT

ENG 3 VALVE IN TRANSIT

GRD INTERCONNECT OPEN CLOSE



LOWER FE PANEL

Hydraulic System A Fluid Shutoff Valve switches (Engine 1/2)
CLOSE position shuts off hydraulic fluid to respective pump

Electrical Hydraulic Pump 1 Switch (System B)

HYDRAULIC SYSTEM A: Engine-Driven hydraulic pumps. System A is used to operate trailing edge flaps, leading edge flaps and slats, outboard flight spoilers, ground spoilers, landing gear, nose wheel brakes and steering, one side of the aileron power unit, one side of each of the two elevator power units, the lower rudder power unit and as an alternate source to operate the main wheel brakes through the hydraulic brake interconnect valve.

HYDRAULIC SYSTEM B: Electrical-motor-driven hydraulic pumps. System B is used to operate the inboard flight spoilers, the upper rudder power unit, the aft stairs, one side of the aileron power unit, one side of each of the two elevator power units, and the main wheel brakes.

STANDBY HYDRAULIC SYSTEM: Electrical-motor-driven hydraulic pumps. The standby system is used to operate the lower rudder standby power unit and to drive a hydraulic motor-pump unit in the event that system A pressure is lost. The motor-pump unit pressurizes fluid from the system B auxiliary reservoir to extend the leading edge flaps and slats.

Engine 1 Hydraulic Pump (Engine-Driven) LOW PRESSURE Light (System A)

Electrical Hydraulic Pump 1 LOW PRESSURE Light (System B)

Standby Hydraulic System Overheat Light

Engine 1 Hydraulic Pump Switch (System A)

Standby Hydraulic System ON Light

Hydraulic Fluid Standby System Quantity (US Gal)

Hydraulic System A Overheat Light

Hydraulic System B Overheat Light

No Equipment Cooling Light

Elevator Feel Different Pressure Light

Hydraulic Ground Interconnect Switch
Connects Hydraulic system B pressure to system A-powered units when APU on bus or external power plugged in.

Hydraulic System A Pressure (x1000 psi)

Hydraulic Fluid System A Quantity (US Gal)

Hydraulic System B Pressure (x1000 psi)

Hydraulic Fluid System B Quantity (US Gal)

Oil Cooler Constant-Speed Drive Switch

Rudder Load Limiter Active Light



LOWER FE PANEL

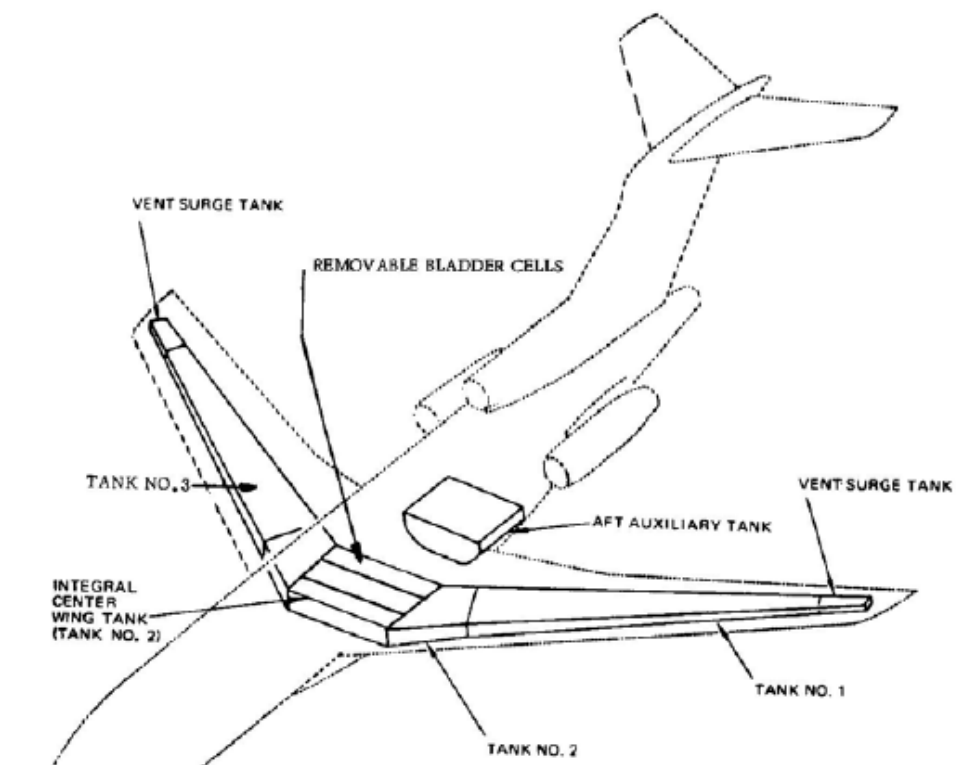
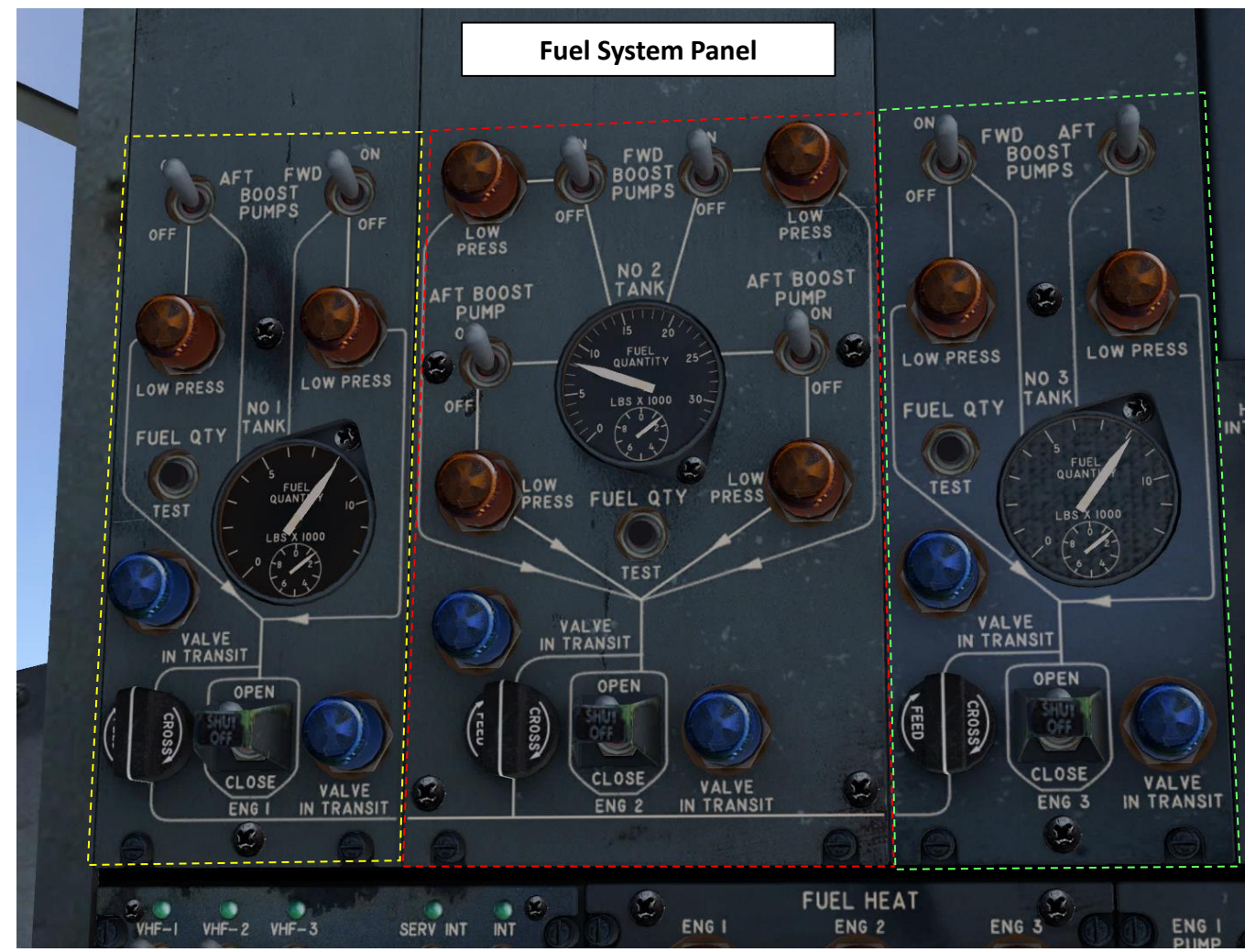

- Fuel Tank No. 1:
Left Wing Tank
- Fuel Tank No. 2:
Fuselage Tank
- Fuel Tank No. 3:
Right Wing Tank

These panels are basically schematic representations of the whole fuel system of the aircraft, including fuel lines, fuel pumps and fuel valves..

LOWER FE PANEL

Left Wing Tank Aft Boost Pump Switch

Left Wing Tank Forward Boost Pump Switch

Left Wing Tank Forward Boost Pump Low Pressure Light

Left Wing Tank Aft Boost Pump Low Pressure Light

Left Wing Tank Fuel Quantity Test Switch

Fuel Crossfeed Valve in Transit Light

Fuel Crossfeed Selector (Close/Open)

Engine 1 Fuel Shutoff Valve Switch (Close/Open)

Engine 1 Fuel Shutoff Valve in Transit Light

Left Wing Tank Fuel Quantity Indicator (lbs)

ON OFF FWD BOOST PUMPS

LOW PRESS

FUEL QTY TEST

VALVE IN TRANSIT

FEED CROSS SHUT OFF OPEN

FUEL HEAT ENG 2 ENG 3

NO 2 TANK

FUEL QUANTITY LBS X 1000

TEST

VALVE IN TRANSIT

FEED CROSS SHUT OFF OPEN CLOSE ENG 2

ENG 1

ON OFF FWD BOOST PUMPS

LOW PRESS

FUEL QTY TEST

VALVE IN TRANSIT

FEED CROSS SHUT OFF OPEN CLOSE ENG 3

ENG 3

NO 3 TANK

FUEL QUANTITY LBS X 1000

VALVE IN TRANSIT

FEED CROSS SHUT OFF OPEN CLOSE ENG 3

ENG 3

Hydraulic Brake Interconnect ON Light
Illuminated when Valve is Open

HYD BRAKE INTERCONNECT ON

OPEN

CLOSE

Hydraulic Brake Interconnect Switch
Opens or closes valve used to pressurize brake system with hydraulic system A.

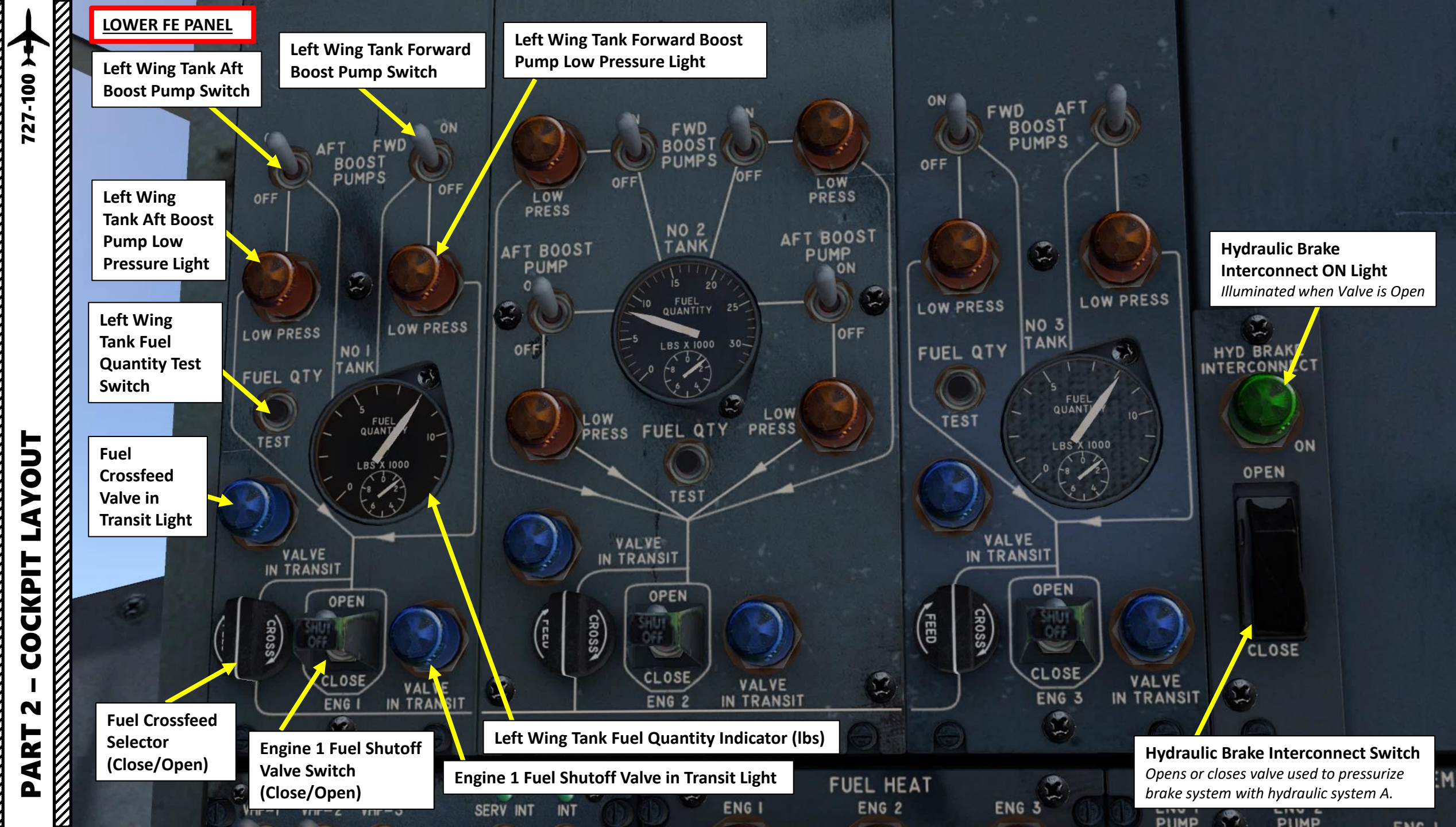

LOWER FE PANEL

Circuit Breaker Panel Brightness Control

Flight Engineer Panel Background Brightness Control

Fluor Switch (Fluorescent Lights)

Oil Quantity Indicator
(Engine 1 Oil Tank)

Oil Temperature Indicator
(Engine 1 Oil Tank, in deg C)

Oil Pressure Indicator
(Engine 1 Oil Tank, in psi)

Flight Engineer Panel Brightness Control

Doors Warning System Annunciators

Flight Engineer Table Brightness Control

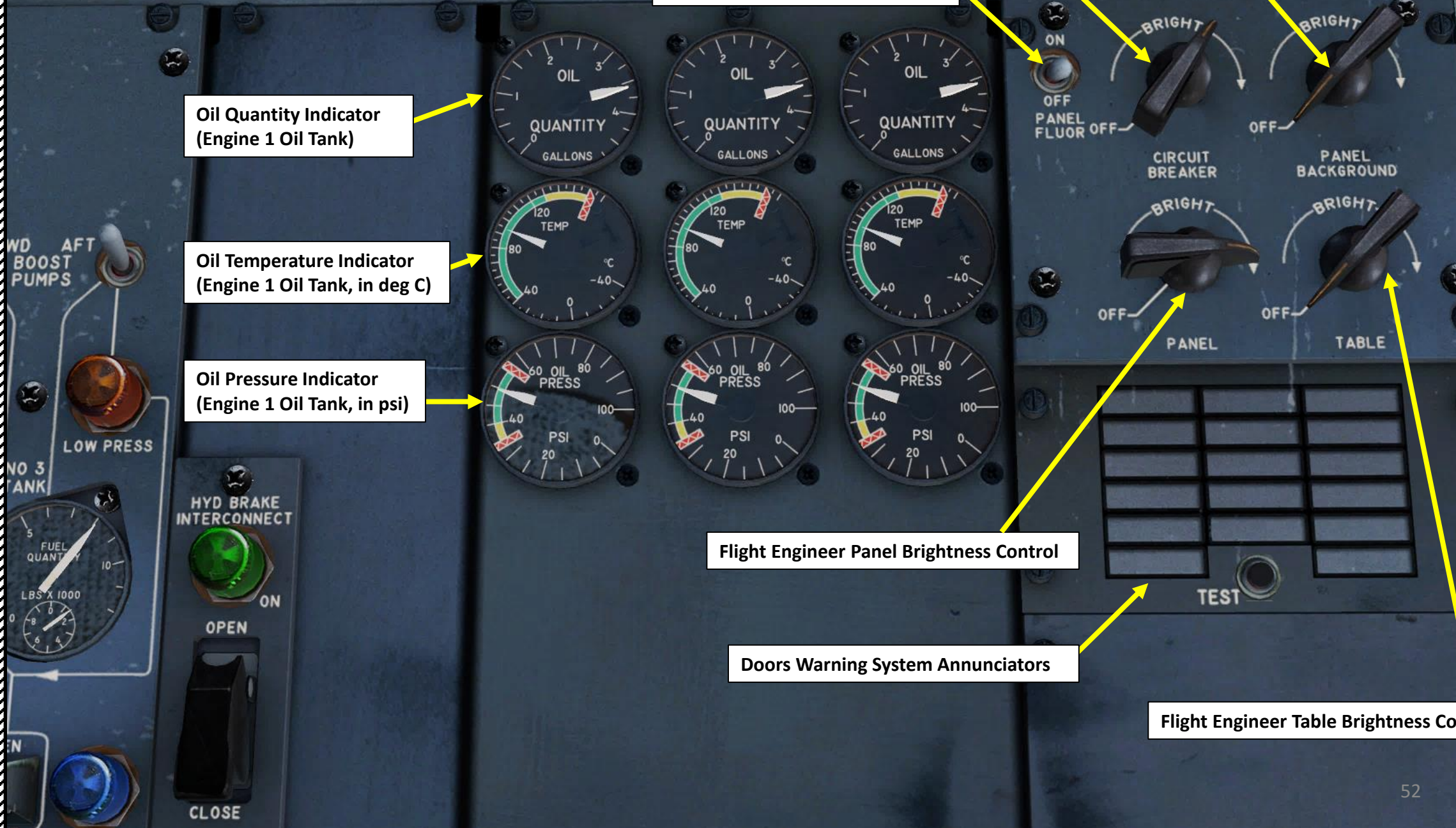

Engine 1 Bus Tie Breaker
CLOSE: ON
TRIP: OFF

Engine 1 Generator Breaker
CLOSE: ON
TRIP: OFF

Engine 1 Bus Tie Circuit Open (OFF) Light

Engine 1 Generator Circuit Open (OFF) Light

Engine 1 Generator Field OFF Light

Frequency Control Knob

Engine 1 KW/KVAR Load On Generator

Engine 1 Generator Field Breaker
CLOSE: ON
TRIP: OFF

AC Meter Selector
APU / BUS TIE / GENERATOR 1 / GENERATOR 2 / GENERATOR 3 / EXTERNAL POWER

UPPER FE PANEL

Residual Volts Switch
AC Voltmeter scale changes from 150 to 30 volts

AC Voltmeter (Volts)

Frequency Meter

Engine 1 Strut Overheat Light

Lower Aft Body Overheat Light

Engine 2 Strut Overheat Light

AC Meters Synchronization Light

Overheat Test Switch

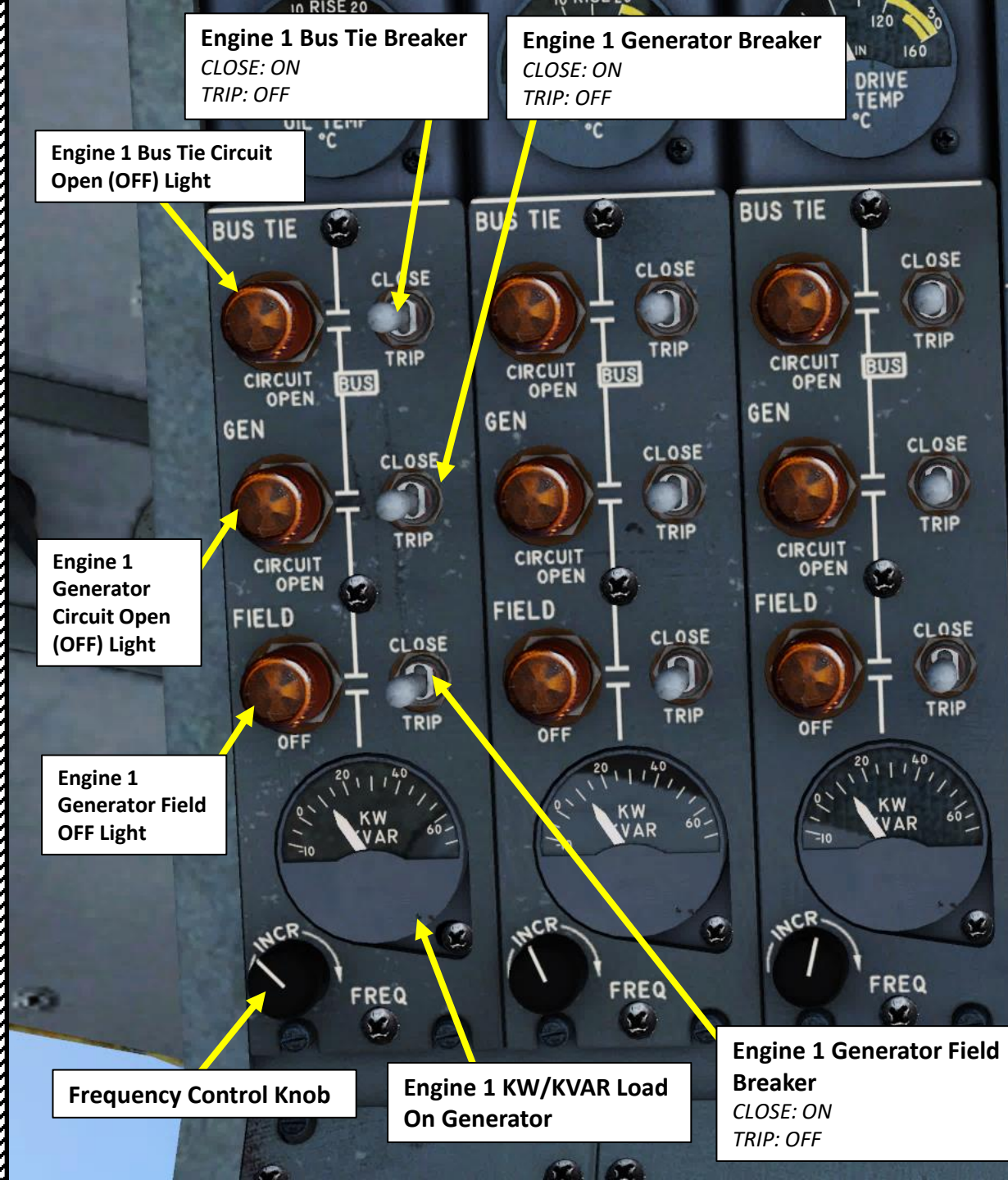
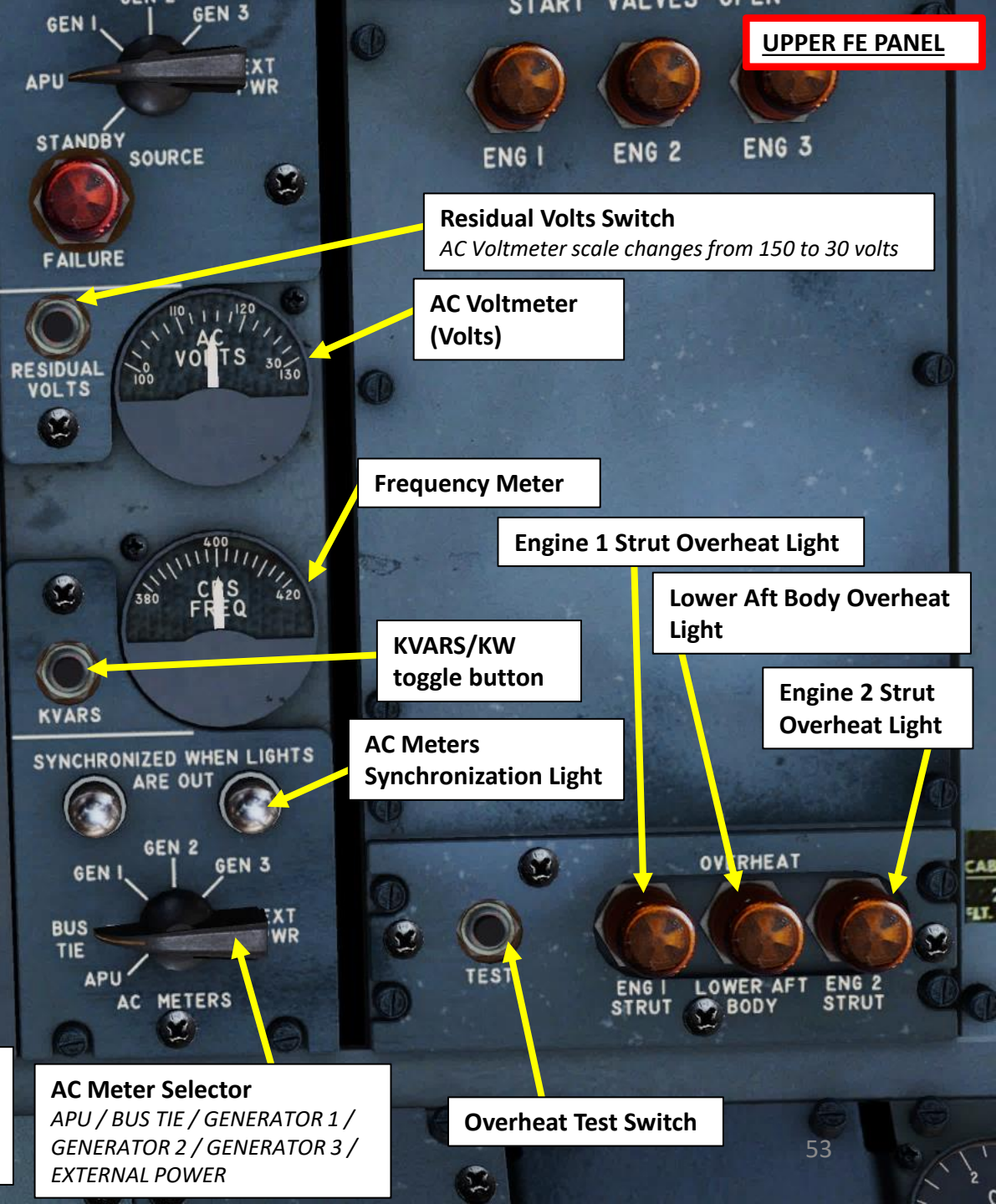

UPPER FE PANEL

START VALVES OPEN



Engine 1, 2 & 3 Start Valves Open Lights



Cabin Altimeter / Differential Pressure Indicator



Cabin Rate of Climb Indicator (x1000 ft/min)

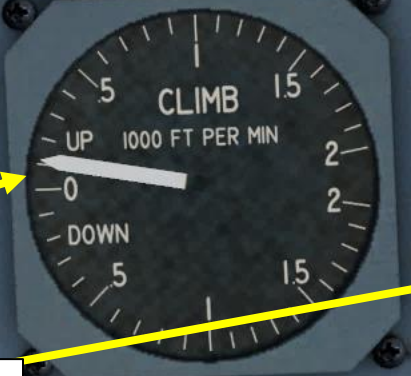

Cabin Pressure Flight Altitude Setting



Cabin Pressure Landing Altitude Setting

Cabin Pressure Flight/Ground Switch

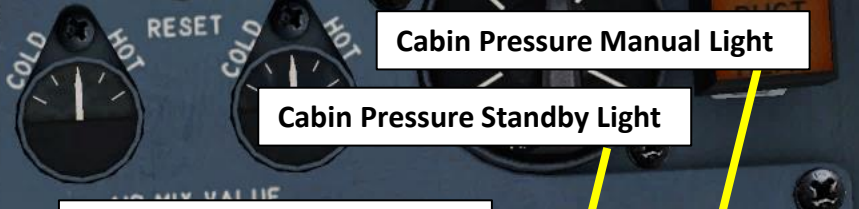

Cabin Pressure Off Schedule Descent Light

Cabin Pressure Auto Fail Light

Cabin Pressure Manual Light

Cabin Pressure Standby Light

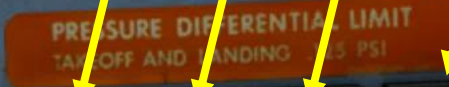

Cabin Pressurization Rate Selector



Outflow Valve Position Indicator



Outflow Valve Manual Control Switch



Cabin Pressurization Mode Selector

Cabin Pressure Altitude Selected Setting

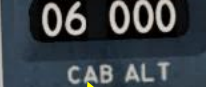

UPPER FE PANEL

Generator CSD (Constant Speed Drive) 1 Low Oil Pressure Light

Galley 1 & 2 Power Switch

Galley 3 & 4 Power Switch

External Power Connected Light

Generator CSD (Constant Speed Drive) 1 Disconnect Switch

External Power Switch

Engine 1 Generator Drive Oil Temperature Switch

- RISE: Temperature gauges indicate oil temperature difference between inlet and outlet ports of the CSD
- IN: Gauges temperature of oil entering CSD on IN scale

Generator CSD (Constant Speed Drive) 1 Oil Temperature (deg C)

Essential Power Source Selector
STANDBY / APU / Generator 1 / Generator 2 / Generator 3 / External Power

Essential Power Failure Warning Light



UPPER FE PANEL



DC Voltmeter



DC Ammeter

Battery Switch



Flight Crew Oxygen Pressure Indicator (x100 psi)



Passenger Oxygen Pressure Indicator (x100 psi)



AC GENERATOR DRIVE

WARNING - GEN DRIVE CAN BE RECONNECTED ONLY ON GROUND

DISCONNECT LOW PRESS DISCONNECT LOW PRESS DISCONNECT LOW PRESS

ENG 1 ENG 2 ENG 3

RISE IN RISE IN RISE IN

DC Meter Selector
Battery
Essential Transformer Rectifier (TR)
TR1
TR2

GALLEY POWER

ON OFF ON OFF

1 & 2 3 & 4

EXTERNAL POWER

ON OFF

AC CONNECTED

GRD SERVICE

CREW PASSENGER

ON NORMAL

OXYGEN SYSTEM

Passenger Oxygen Switch

AUTO PACK TRIP

RESET

AFT CABIN ZONE TEMP

COOLER WARMER OVERHEAT

Oxygen Pressure Indicating Light (ON)

ESSENTIAL POWERS

GEN 1 GEN 2 GEN 3

APU STANDBY SOURCE

FAILURE

START VALVES OPEN

ENG 1 ENG 2 ENG 3

UPPER FE PANEL

Auto PACK (Pneumatic Air Conditioning kit) Trip Cutout Switch

Aft Cabin Zone Temperature Control Valve Position Indicator

Aft Cabin Zone Overheat Light

Air Temperature Selector

Passenger Cabin Duct Overheat Light

Control Cabin Temperature Selector

Control Cabin & Passenger Cabin Air Mix Valve Indicators

Passenger Cabin Temperature Selector

Aft Cabin Zone Temperature Switch (Cooler/Warmer)

Control Cabin Duct Overheat Light

Altitude Horn Cutout Button

Air Temperature Indicator (deg C)



UPPER FE PANEL

Control Cabin PACK (Pneumatic Air Conditioning Kit) Pressure (psi)

Passenger Cabin PACK (Pneumatic Air Conditioning Kit) Pressure (psi)

Cooling Doors Position Indicator

Gasper Fan Switch

Cargo Heat Outflow Switch

Air Conditioning PACK Reset Switch

Cooling Doors Switch

Auto PACK Trip Armed Light

Left Air Conditioning PACK Trip Off Light

Engine 1 Bleed Air Valve Switch

Engine 1 Bleed Air Trip Off Light

Intermediate Bleed Air Valve Switch

Pneumatic Duct Pressure Indicator (psi)

Bleed Air High Temperature Light

Engine 2 Bleed Air Valve Switch

Intermediate Bleed Air Valve Switch

Engine 3 Bleed Air Trip Off Light

Engine 3 Bleed Air Valve Switch

Right Air Conditioning PACK Trip Off Light



AFT FUEL DUMP PANEL



Tank 2 Fuel Dump Valve Control Switch

Tank 1 Fuel Dump Valve Control Switch

Left Fuel Dump Nozzle Valve Control Switch

Left Fuel Dump Nozzle Valve In Transit Light

Fuel Dump Valve In Transit Lights

Tank 2 Fuel Dump Valve Control Switch

Tank 3 Fuel Dump Valve Control Switch

Right Fuel Dump Nozzle Valve Control Switch

Right Fuel Dump Nozzle Valve In Transit Light

TRIP DATE

7 0 7 1 2 0

REPEAT

RECORDING HOURS REMAINING

EVENT

Flight Recorder Remaining Recording Hours

AFT APU PANEL

APU Circuit Open Light
Illuminated when APU electrical circuit is OPEN

APU Master Switch
OFF / ON / START

APU Generator Field Relay Light
Illuminated when APU Field is OFF

APU Auto Fire Shutdown Arming Switch

APU AC Ammeter (Amperes)

APU (Auxiliary Power Unit) Generator Breaker Switch
TRIP: Circuit is Open/Tripped (Generator OFF)
CLOSE: Circuit is Closed (Generator ON)

APU Fire Switch (Arms Extinguisher Button) & Warning Light (Fire is detected)

APU Extinguisher Bottle Discharge Button

APU Generator Field Relay Breaker Switch
• CLOSE: engages APU Field and allows APU generator to be turned ON.
• TRIP: disconnects APU Field.

APU Fire Detection Test Switch

APU EGT (Exhaust Gas Temperature) (x100 deg C)



AFT APU PANEL

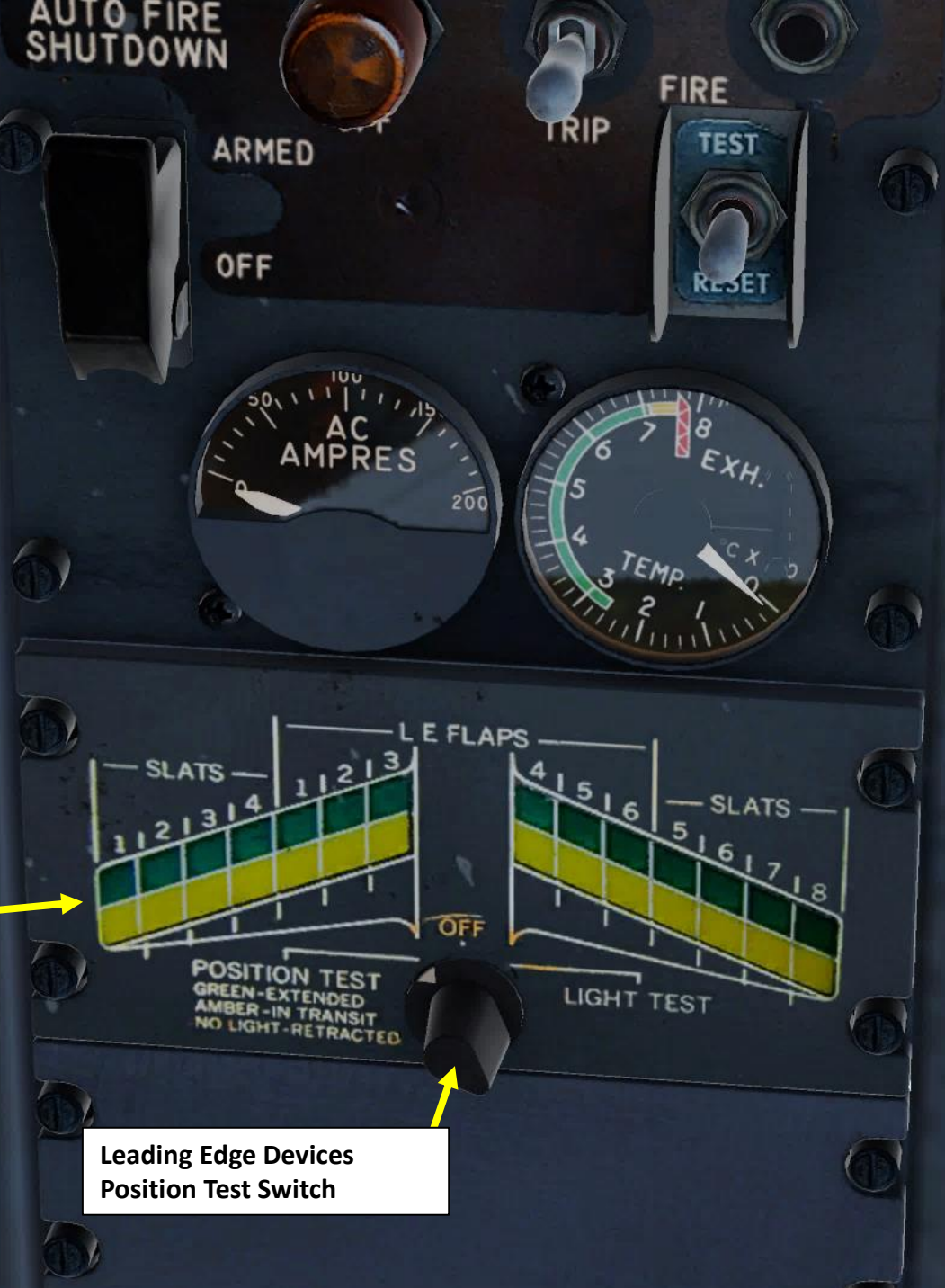

Leading Edge Devices Annunciator Panel
 GREEN: Extended
 YELLOW: In Transition
 NO LIGHT: Retracted

Leading Edge Devices Position Test Switch

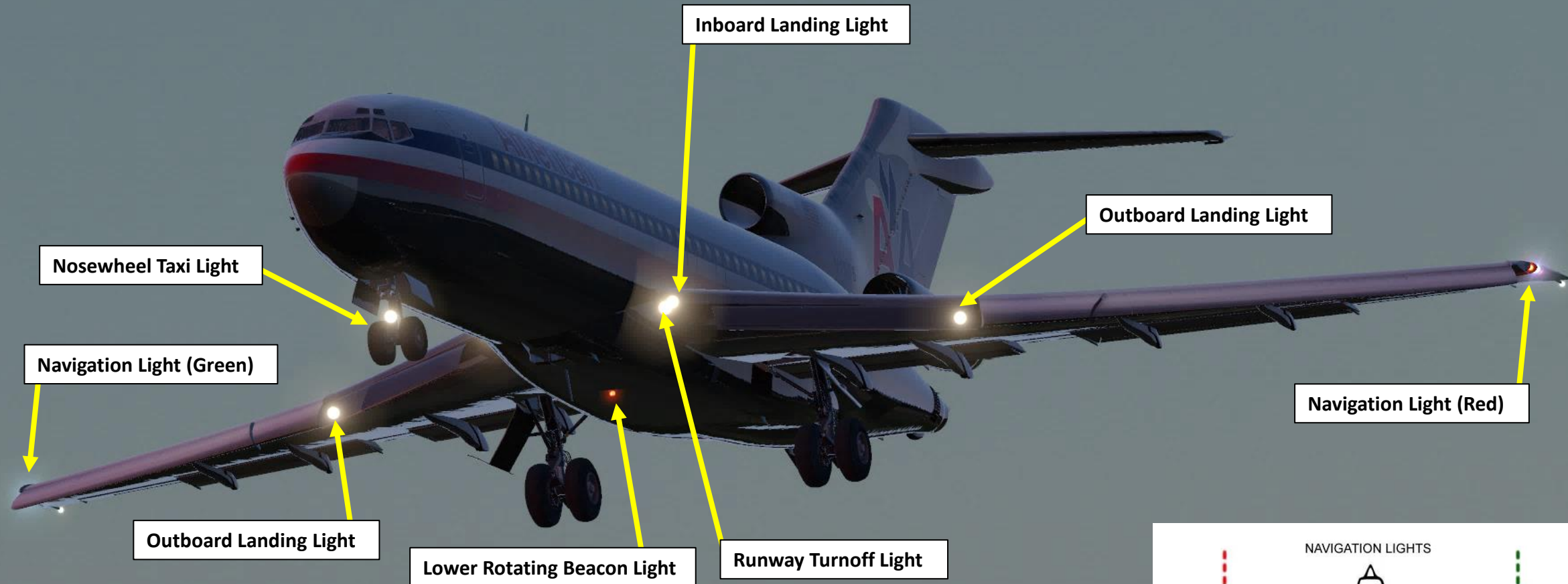

- **Landing Lights:** used to illuminate runway during landing
- **Runway Turnoff Lights:** used to aid the crew in seeing the turn in the taxiway/runway
- **Taxi Lights:** used to illuminate area in front of nosewheel during taxi
- **Beacon (Anti-Collision) Lights:** flashing red light used to prevent collisions and warn others that aircraft is active and engines are running
- **Navigation (Position) Lights:** red, green and white lights help you know the direction of an aircraft (red is on the left, green on the right, white on the tail).
- **Strobe (Anti-Collision) Lights:** pulsating white lights used when aircraft enters a runway in use to increase visibility
- **Wing Lights:** used to check wing at night (i.e. verify if there is ice accumulation on the wing)
- **Logo Light:** used to illuminate the airline's logo painted on the tail

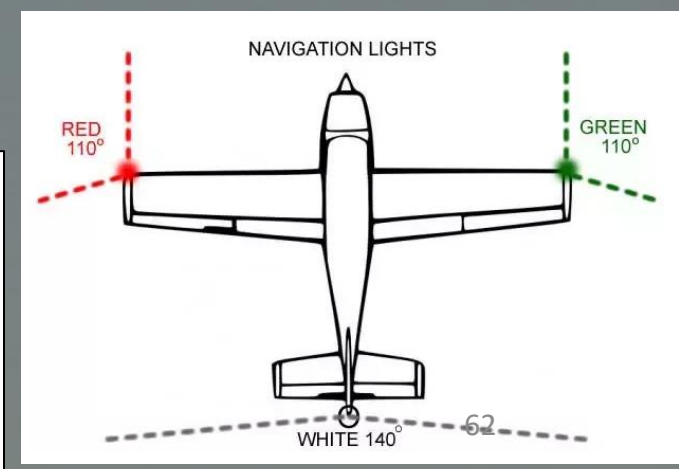

Upper Rotating Beacon Light

Wing Light

Strobe Light (Flashing White)

Wing Tip Mounted Tail Light

Logo Light

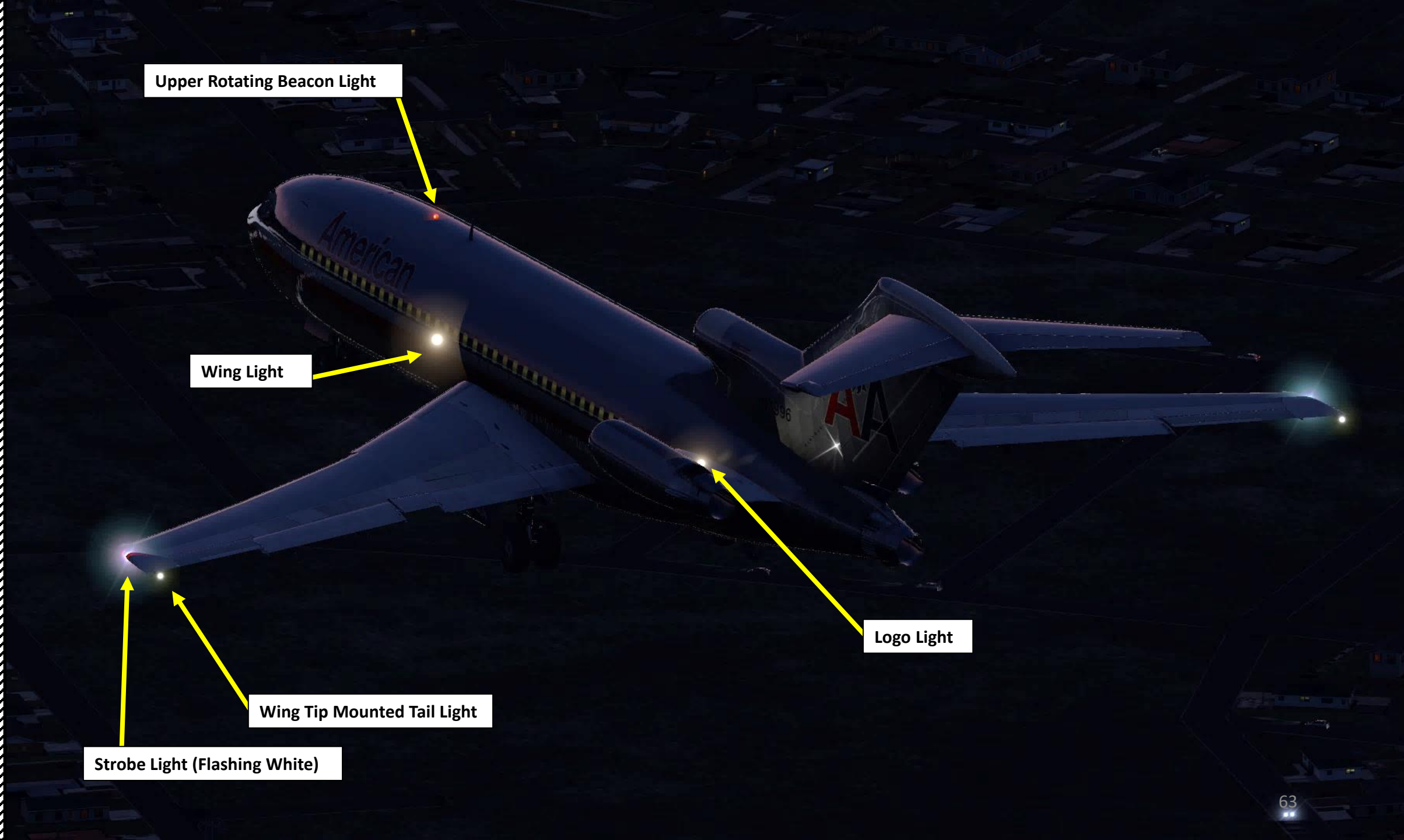

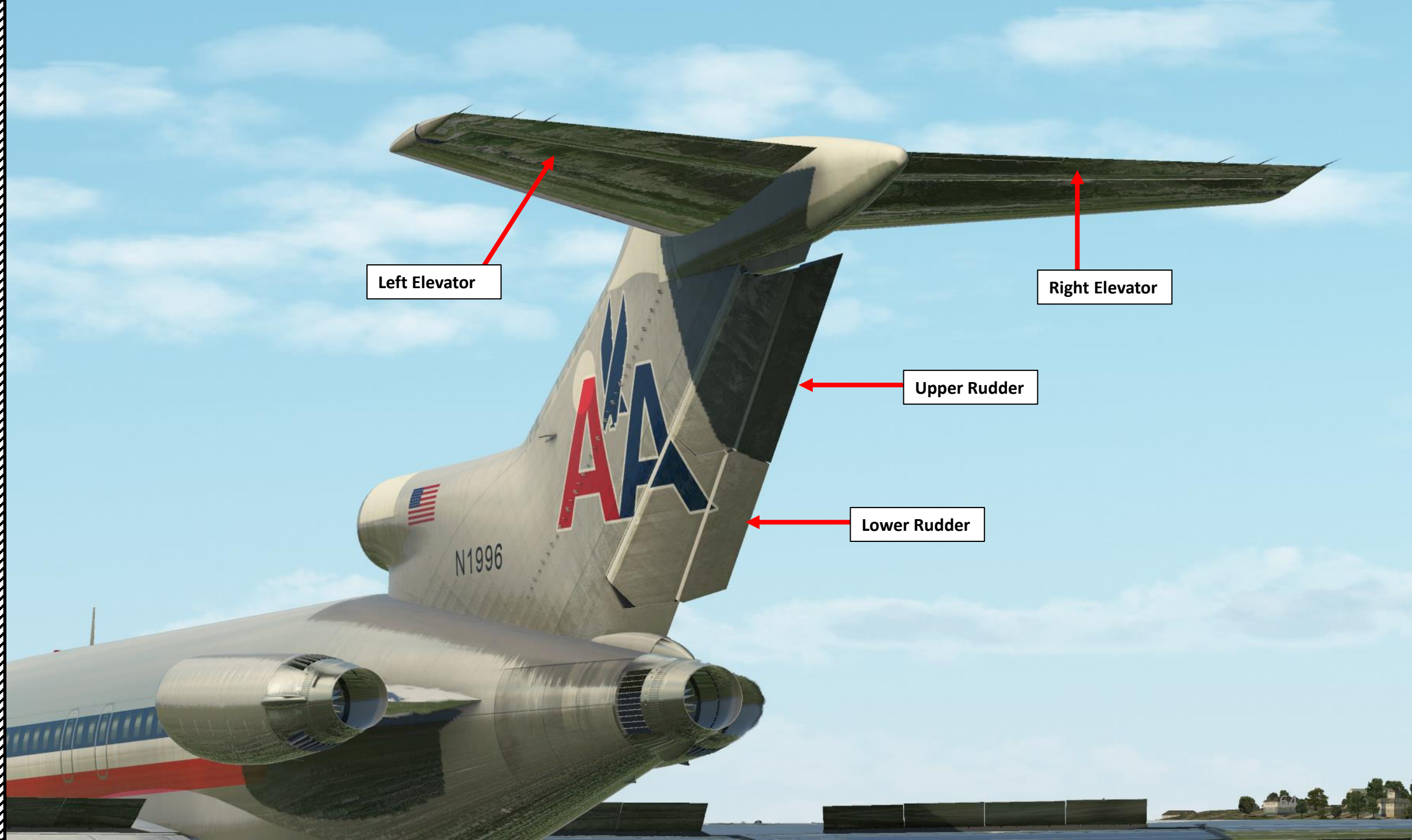

Left Elevator

Right Elevator

Upper Rudder

Lower Rudder

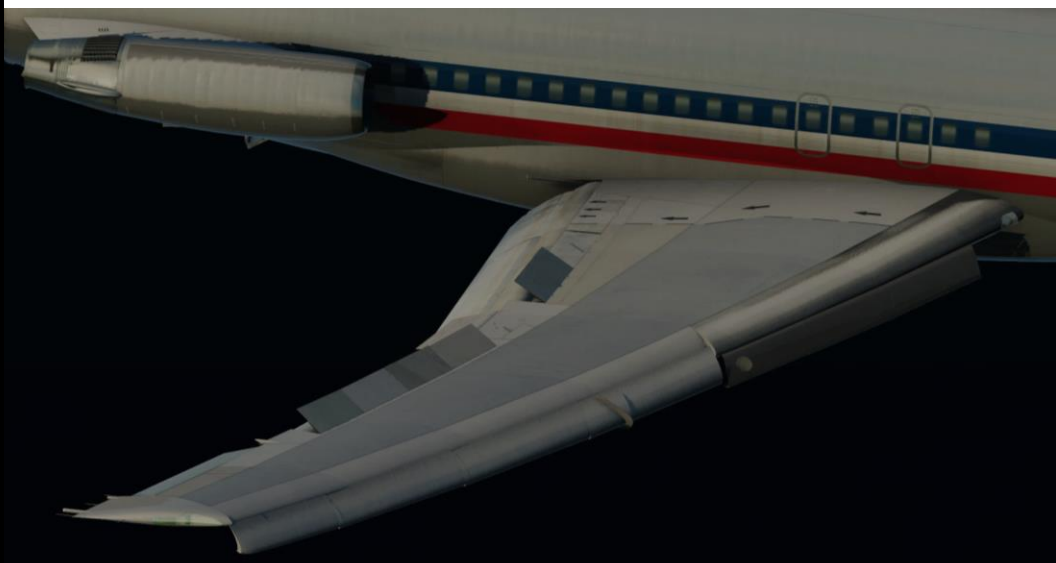
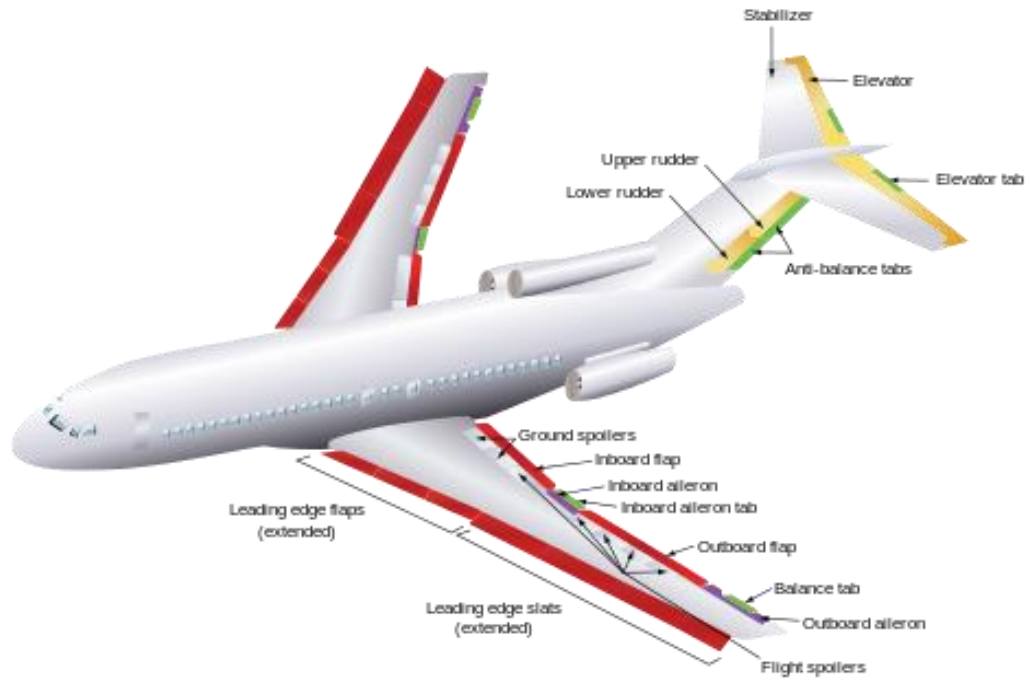

PLANNING THE FLIGHT

In real life, you cannot just fly a 727 wherever and whenever you please. Just like on land, the sky is littered with an intricate network of waypoints and aerial highways. Therefore, it is necessary to plan your flight route and to determine how much fuel you will need to carry in order to reach your destination.

In order to do this, we will use a tool called "Online Flight Planner" available here: <http://onlineflightplanner.org/>

There are a number of fuel planners available online. These estimates may or may not be very accurate. There are specific charts created by Boeing to come up with accurate fuel estimates which are unfortunately not available to the public. Therefore, for the sake of simplicity we will just use the fuel estimate that comes from the Flight Planner, which is good enough for the purpose of this tutorial.



Airways:

CYYZ DCT SIKBO Q140 HANKK Q935 PONCT STAR KBOS

Provided by RouteFinder

METAR:

Departure: CYYZ 200200Z 16006KT 6SM BR BKN003 BKN045 13/11 A2983 RMK ST5SC2 SLP104 DENSITY ALT 600FT

Destination: KBOS 200254Z 00000KT 1 1/2SM BR OVC007 12/11 A3008 RMK AO2 SFC VIS 3 RAB0155E32 SLP184 P0001 60003 T01220111 58019

Provided by CheckWX API

Fuel quantity for Boeing 727-100

	Fuel	Time
Fuel Usage	11534 lbs	01:19
Reserve Fuel	10891 lbs	01:15
Fuel on Board	22425 lbs	02:34

Provided by Fuelplanner.com

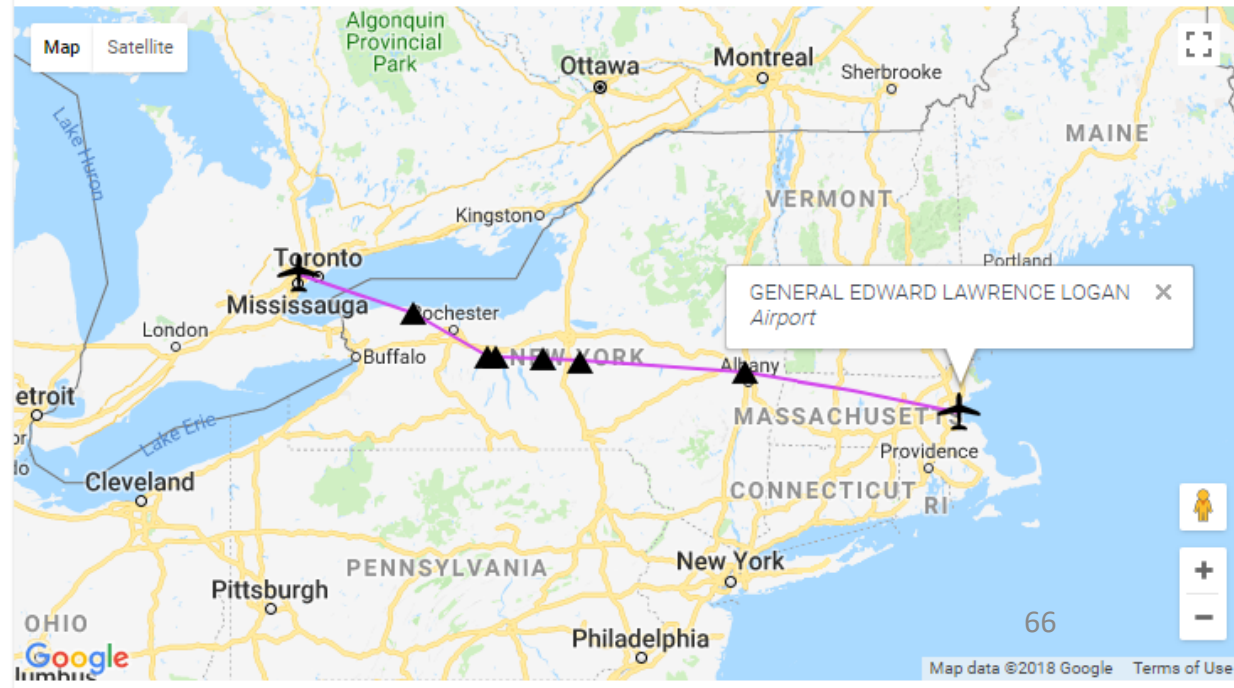

PLANNING THE FLIGHT

Today's flight will start from **TORONTO / LESTER B. PEARSON INTERNATIONAL AIRPORT (CYYZ)** and our destination will be **BOSTON LOGAN INTERNATIONAL AIRPORT (KBOS)**.

Using the "Online Flight Planner" available here: <http://onlineflightplanner.org/> we will enter the Departure airport (CYYZ), the Destination airport (KBOS) and the AIRAC Cycle desired (we will use the **AIRAC cycle 1805** as explained on the next page).

Click on **CREATE PLAN** to generate a flight plan.

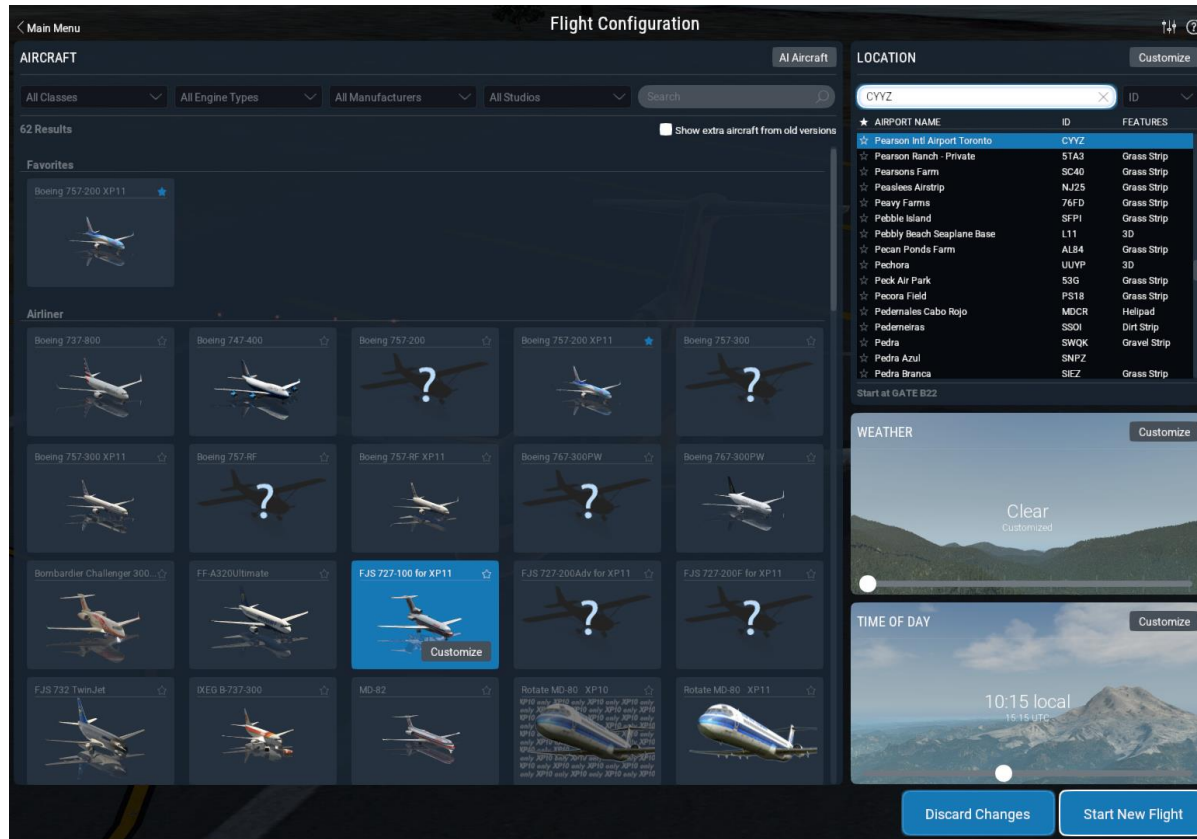

Route

Choose an airport

Info

Desired file formats

.rte (Flight One ATR) .txt (FlightFactor A320) .fgfp (FlightGear)

.flp (Airbus X) .fltplan (iFly) .fms (X-Plane)

.fms (X-Plane 11) .kml (Google Earth) .mdr (Leonardo MD80)

.pdf .pln (FS 2004) .pln (FS X)

.route (iFly 747 V2) .rte (PMDG) .rte (Level-D)

.rte (QualityWings) .sfp (Squawkbox)(New) .xml (TFDi Design 717)

.txt (JarDesign A320) .ufmc (UFMC) .fmc (VasFMC)

Swap departure and destination

Distance: 386.5 nm

Departure → CYYZ Country Code

Destination → KBOS Country Code

AIRAC Cycle → 1805

Altitude range (Min/Max) → FL330 → FL330

Level → Both

Aircraft → Boeing 727-100

Fuel unit → lbs

Use SIDs Use STARs RNAV equipped

TACAN routes NATs

Reset to defaults

Create plan ← Click CREATE PLAN

727-100

PART 3 - FLIGHT PLANNING

PLANNING THE FLIGHT

In aviation, an **Aeronautical Information Publication** (or **AIP**) is defined by the International Civil Aviation Organization as a publication issued by or with the authority of a state and containing aeronautical information of a lasting character essential to air navigation. It is designed to be a manual containing thorough details of regulations, procedures and other information pertinent to flying aircraft in the particular country to which it relates. It is usually issued by or on behalf of the respective civil aviation administration. AIPs are kept up-to-date by regular revision on a fixed cycle. For operationally significant changes in information, the cycle known as the **AIRAC (Aeronautical Information Regulation And Control)** cycle is used: revisions are produced every 56 days (double AIRAC cycle) or every 28 days (single AIRAC cycle). These changes are received well in advance so that users of the aeronautical data can update their flight management systems (FMS). (Source: https://en.wikipedia.org/wiki/Aeronautical_Information_Publication)

In other words, some Youtube tutorials might show you flight routes with certain waypoints that got changed with more recent AIRAC updates. Some waypoints or even airports may not exist anymore. For the purpose of this tutorial, we will use AIRAC cycle 1605 since I'm writing this tutorial in early May, 2018 (period **05**) **2018** (AIRAC cycle **1805**).

This is not ideal since some navigation aids may be out of date, but for the Boeing 727 it will not be that big of a deal since the old 727 variant we have does not have a modern FMS (Flight Management System) installed like the ones on the upgraded/modernized 727s. We will rely on the waypoint coordinates and plug them in the CIVA and we will track VOR beacons for departure and arrival routes.

AIRAC effective dates (28-day cycle) [edit]

The current AIRAC cycle is 1605 (effective 28 Apr 2016).

#	2003	2004*	2005	2006	2007	2008*	2009	2010	2011	2012*	2013	2014	2015	2016*	2017	2018	2019	2020*
01	23 Jan	22 Jan	20 Jan	19 Jan	18 Jan	17 Jan	15 Jan	14 Jan	13 Jan	12 Jan	10 Jan	9 Jan	8 Jan	7 Jan	5 Jan	4 Jan	3 Jan	2 Jan
02	20 Feb	19 Feb	17 Feb	16 Feb	15 Feb	14 Feb	12 Feb	11 Feb	10 Feb	9 Feb	7 Feb	6 Feb	5 Feb	4 Feb	2 Feb	1 Feb	31 Jan	30 Jan
03	20 Mar	18 Mar	17 Mar	16 Mar	15 Mar	13 Mar	12 Mar	11 Mar	10 Mar	8 Mar	7 Mar	6 Mar	5 Mar	3 Mar	2 Mar	1 Mar	28 Feb	27 Feb
04	17 Apr	15 Apr	14 Apr	13 Apr	12 Apr	10 Apr	9 Apr	8 Apr	7 Apr	05 Apr	4 Apr	3 Apr	2 Apr	31 Mar	30 Mar	29 Mar	28 Mar	26 Mar
05	15 May	13 May	12 May	11 May	10 May	8 May	7 May	6 May	5 May	03 May	2 May	1 May	30 Apr	28 Apr	27 Apr	26 Apr	25 Apr	23 Apr
06	12 Jun	10 Jun	9 Jun	8 Jun	7 Jun	5 Jun	4 Jun	3 Jun	2 Jun	31 May	30 May	29 May	28 May	26 May	25 May	24 May	23 May	21 May
07	10 Jul	8 Jul	7 Jul	6 Jul	5 Jul	3 Jul	2 Jul	1 Jul	30 Jun	28 Jun	27 Jun	26 Jun	25 Jun	23 Jun	22 Jun	21 Jun	20 Jun	18 Jun
08	7 Aug	05 Aug	4 Aug	3 Aug	2 Aug	31 Jul	30 Jul	29 Jul	28 Jul	26 Jul	25 Jul	24 Jul	23 Jul	21 Jul	20 Jul	19 Jul	18 Jul	16 Jul
09	4 Sep	02 Sep	1 Sep	31 Aug	30 Aug	28 Aug	27 Aug	26 Aug	25 Aug	23 Aug	22 Aug	21 Aug	20 Aug	18 Aug	17 Aug	16 Aug	15 Aug	13 Aug
10	2 Oct	30 Sep	29 Sep	28 Sep	27 Sep	25 Sep	24 Sep	23 Sep	22 Sep	20 Sep	19 Sep	18 Sep	17 Sep	15 Sep	14 Sep	13 Sep	12 Sep	10 Sep
11	30 Oct	28 Oct	27 Oct	26 Oct	25 Oct	23 Oct	22 Oct	21 Oct	20 Oct	18 Oct	17 Oct	16 Oct	15 Oct	13 Oct	12 Oct	11 Oct	10 Oct	8 Oct
12	27 Nov	25 Nov	24 Nov	23 Nov	22 Nov	20 Nov	19 Nov	18 Nov	17 Nov	15 Nov	14 Nov	13 Nov	12 Nov	10 Nov	9 Nov	8 Nov	7 Nov	5 Nov
13	25 Dec	23 Dec	22 Dec	21 Dec	20 Dec	18 Dec	17 Dec	16 Dec	15 Dec	13 Dec	12 Dec	11 Dec	10 Dec	8 Dec	7 Dec	6 Dec	5 Dec	3 Dec
14																		31 Dec



Modern FMS installed on a 737-800WL

Note: * = leap year containing 29 Feb (2004, 2008, 2012, 2016, etc.)

PLANNING THE FLIGHT

FUEL PLANNING

For a flight of approx. **2.5 hours**, fuel planning can be estimated by using <http://onlineflightplanner.org/> or by using the Fuel Planning charts from a great website called www.boeing-727.com.

The OnlineFlightPlanner fuel estimate gives us about 22500 lbs of fuel for a 2.5 hour flight, while the fuel planning chart from Boeing-727.com gives us a more conservative estimate of approx. 27000 lbs of fuel.

Source for Fuel Planning Charts:

Boeing 727-100 chart:
<http://www.boeing-727.com/Data/fluidfuel/fuel%20graph%20100%20series.html>

Boeing 727-200 chart:
<http://www.boeing-727.com/Data/fluidfuel/fuel%20graph%20200%20series.html>

To keep things simple, we'll take the more conservative estimate and go with **27,000** lbs of fuel. Write that number down, we'll need it later.

Write this fuel weight down!

Fuel estimate from Boeing-727.com

Fuel estimate from Online Flight Planner

Fuel quantity for Boeing 727-100

	Fuel	Time
Fuel Usage	11534 lbs	01:19
Reserve Fuel	10891 lbs	01:15
Fuel on Board	22425 lbs	02:34

Fuel Graph (How Goes It) 100 Series

Fuel Planning Chart: 727-100

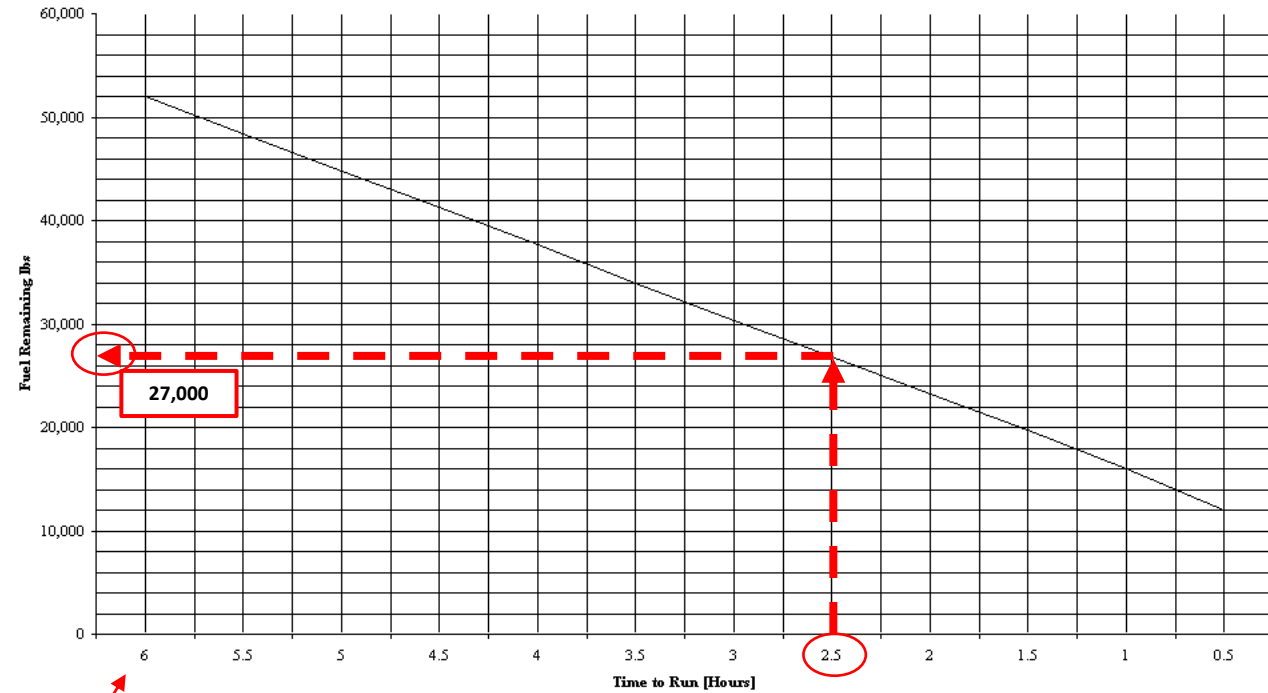

Fuel (How Goes It) 200 Series

Fuel Planning Chart: 727-200

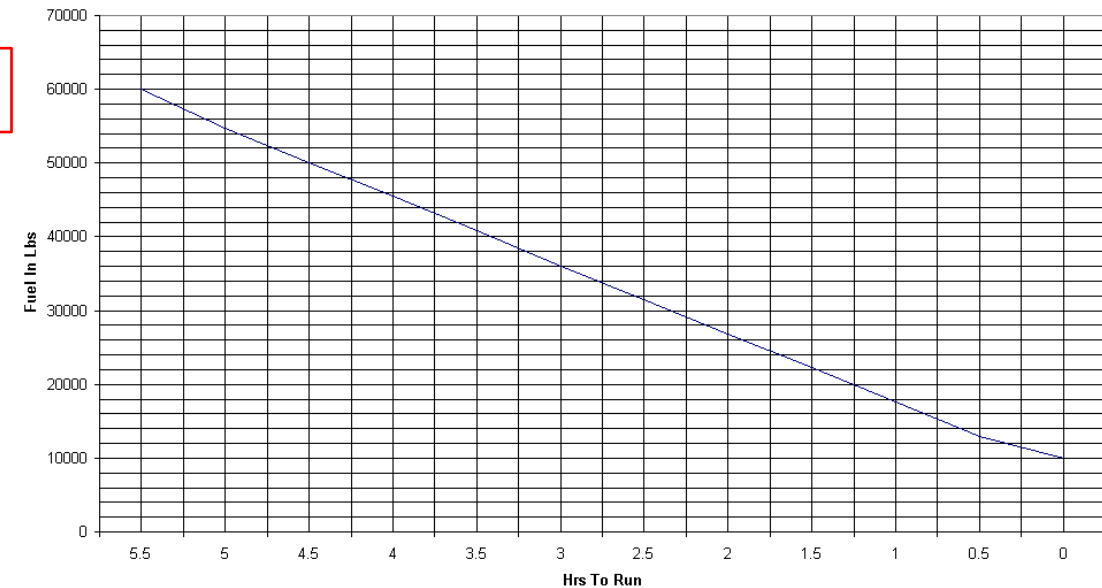

PLANNING THE FLIGHT

FLIGHT ROUTE

The flight route we could take from onlineflightplanner.com is:
CYYZ DCT SIKBO Q140 HANKK Q935 PONCT STAR KBOS

Write this route down!

But what does it all mean? Here is a breakdown of this route:

- Depart from Toronto Lester B. Pearson Airport (CYYZ)
- Fly Directly to (DCT) SIKBO VOR or follow a SID (Standard Instrument Departure) route from CYYZ to SIKBO
- Navigate to SIKBO VOR
- Follow Q140 Airway
- Navigate to HANKK VOR
- Follow Q935 Airway
- Navigate to PONCT VOR
- Follow the STAR (Standard Terminal Arrival Route) from PONCT to KBOS
- Land at Boston Logan International Airport (KBOS)

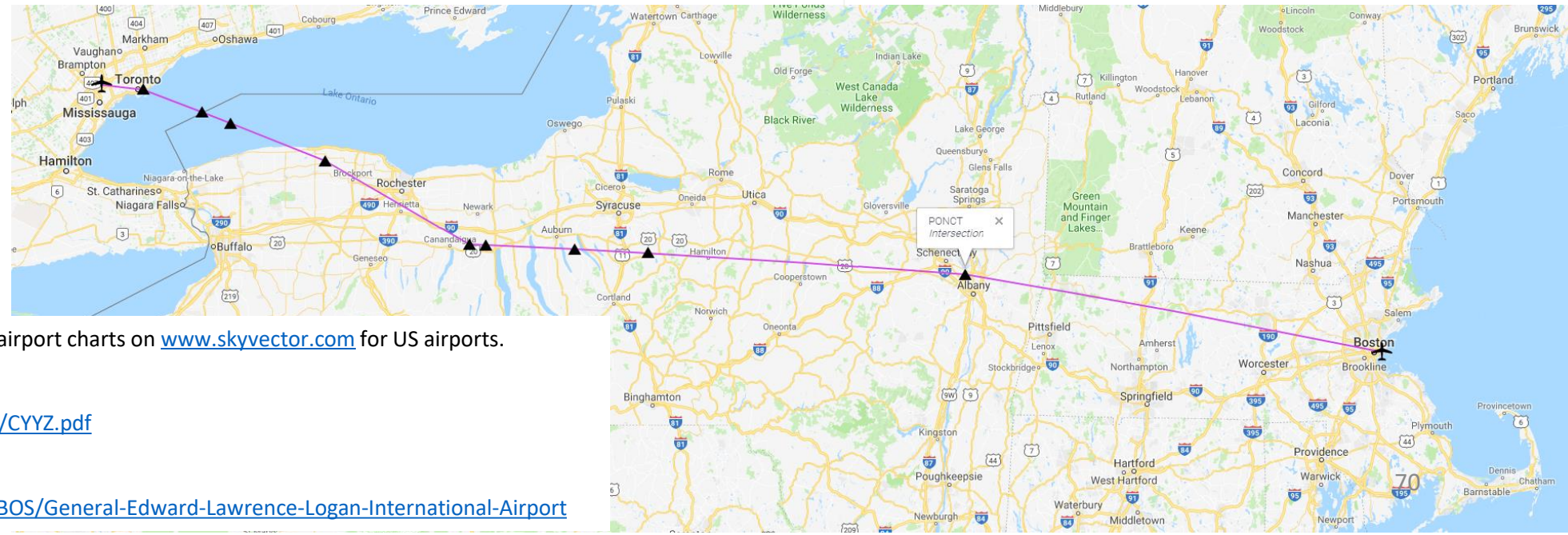

Keep in mind that you can find airport charts on www.skyvector.com for US airports.

CYYZ:

<http://www.fly-sea.com/charts/CYYZ.pdf>

KBOS:

<https://skyvector.com/airport/BOS/General-Edward-Lawrence-Logan-International-Airport>

Lester B. Pearson International Airport (CYYZ) → General Edward Lawrence Logan International Airport (KBOS)

ID	Frequency	Track	Distance (nm)	Coordinates		Name/Remarks
CYYZ	-	0	0	N43°40'36.18"	W079°37'50.36"	LESTER B. PEARSON INTL
SIKBO	-	101	12	N43°39'13.00"	W079°20'57.00"	SIKBO
RAGIX	-	116	18	N43°32'37.78"	W078°57'26.89"	RAGIX
MEDAV	-	116	9	N43°29'19.00"	W078°45'46.00"	MEDAV
AHPAH	-	116	30	N43°18'19.00"	W078°07'35.11"	AHPAH
HANKK	-	124	49	N42°53'41.82"	W077°09'15.21"	HANKK
JOSSY	-	97	5	N42°53'29.93"	W077°02'36.80"	JOSSY
AUDIL	-	97	26	N42°52'18.74"	W076°26'35.07"	AUDIL
FABEN	-	97	22	N42°51'12.04"	W075°57'07.91"	FABEN
PONCT	-	98	94	N42°44'48.83"	W073°48'48.07"	PONCT
KBOS	-	105	126	N42°21'46.60"	W071°00'23.00"	GENERAL EDWARD LAWRENCE LOGAN

A waypoint can be enabled/disabled by clicking on it (except first two and last two waypoints).

11 fixes, 391 nm.

Airways:

CYYZ DCT SIKBO Q140 HANKK Q935 PONCT STAR KBOS

PLANNING THE FLIGHT

FLIGHT ROUTE – PECULIARITIES OF THE BOEING 727 OR WHAT DOES “SLANT ALPHA” MEAN?

Our flight plan is:

CYYZ DCT SIKBO Q140 HANKK Q935 PONCT STAR KBOS

However, back in the 1960’s the network of navigation aids wasn’t as elaborate as it is today. Nowadays, you can plug in the “PONCT” waypoint in the flight management system and the flight computer will know what kind of navigation aid it is, where it is and where you are in relationship to it... but back in the “good old days”, airliners would fly from VOR beacon to VOR beacon, which gave trajectories that were approximative at best. This is why we will disregard Airways in this flight, which will not really help us since the 727 has no way to see anything else than basic navigation beacons.

This brings us to the term “**Slant Alpha**”. You may hear that term in some Youtube tutorials, read about it in flight simulation forums or even air traffic controllers when they are asking what aircraft category a pilot is flying. In simple terms, “Slant Alpha” means that your aircraft only has a transponder mode C and DME (Distance Measuring Equipment) like VOR (VHF Omnidirectional Range). So, no fancy GPS tracking for you. You will have to navigate using VORs and the CIVA INS (Delco Carousel IV-A Inertial Navigation System), which will allow you to plug in waypoint coordinates but accumulates drift error over time, which can make precision flying for terminal navigation close to impossible.

Therefore, in order to have the “complete 727 experience”, this tutorial will show you how to track VORs (mainly those used for our SIDs and STARs) and also how to track waypoints entered in the CIVA.

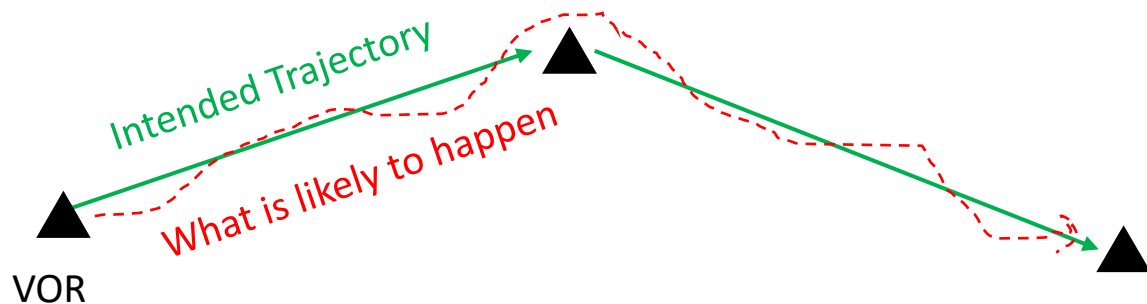

Glossary for Navigation/Communication Equipment

- /X No transponder
- /T Transponder with no Mode C
- /U Transponder with Mode C
- DME
- /D No transponder
- /B Transponder with no Mode C
- /A Transponder with Mode C
- TACAN only
- /M No transponder
- /N Transponder with no Mode C
- /P Transponder with Mode C
- Area navigation (RNAV with LORAN, VOR/DME, or INS)
- /Y No transponder
- /C Transponder with no Mode C
- /I Transponder with Mode C
- Advanced RNAV with transponder and Mode C
- /E Flight Management System (FMS) with DME/DME and IRU positioning update
- /F FMS with DME/DME position updating
- /G Global Navigation Satellite System (GNSS)
- /R Required Navigational Performance (RNP)
- Reduced Vertical Separation Minimum (RVSM)
- /J /E with RVSM
- /K /F with RVSM
- /L /G with RVSM
- /Q /R with RVSM
- /W RVSM



WHAT IS A SID AND A STAR?

A **SID** (Standard Instrument Departure) is a small initial route which leads an aircraft from the runway they've just taken off from to the first point in his/her intended route. An airport usually has a lot of aircraft departing from its runways. To save confusion (and for safety), a busy airport will publish standard routes from its runways to the various routes away from that airport. This way a controller can be sure that even if a steady stream of aircraft is leaving the airport they will all be following in a nice neat line, one behind the other (that's the idea anyhow!).

Standard routes are the preferred method to fly from airport to airport. This is why we use a flight plan generator. Arriving at an airport is just the same. The **STARs** (STandard Arrival Routes) are also published in chart form and allow you to fly into an airport using standard procedures. This way, less communication is again needed with the controllers as (once you have declared your intention or been given a route to fly by name) the controller and you both know exactly how you are going to approach the airport. The end of the STAR route will normally leave your aircraft at a position where controllers can give you final instructions to set you up for a landing.

SIDs and STARs are quite similar to highways; they have speed limits and altitude restrictions at certain waypoints to make sure the air traffic is flying safely and on the same trajectory. It will be your job to respect these restrictions as best you can.

In other words, you can see SIDs and STARs like road junctions in the sky that lead to other waypoints and airways from or to your desired airport. One airport has many SIDs and STARs.

Typically, SIDs and STARs are provided by the ATC (Air Traffic Controller). Since we're doing a tutorial, I will just give you the SID and STAR that we'll use.

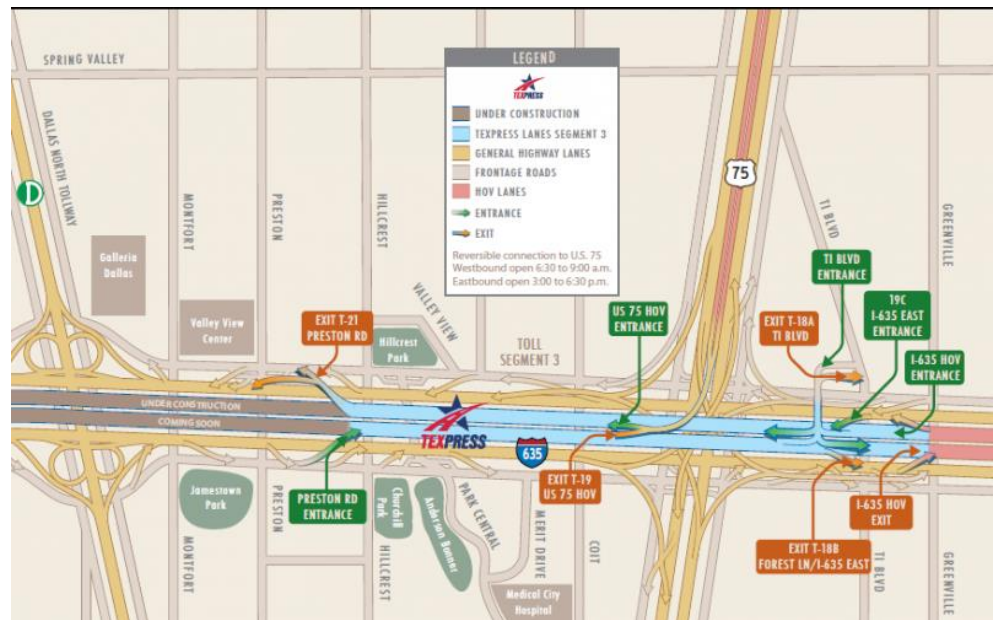

PLANNING THE DEPARTURE - SID

These charts are for the SID (Standard Instrument Departure) from Toronto Pearson (CYYZ). We intend to:

1. Spawn at Gate B22 (personal preference)
2. Taxi towards runway 05 (orientation: 057) using taxiways 3, Alpha-Juliet (AJ), Alpha (A), November (N), Echo (E), Golf (G), Hotel (H) and holding point H6.
3. Depart from CYYZ using the LESTER SEVEN SID from CYYZ. We will fly to a 057 heading until we reach 1000 ft, then we will steer to a 047 heading to a target altitude of 5000 ft (FLO50). We will use the PEARSON (YTP) VOR as a reference navigation aid.
4. After that, we will climb to a cruising altitude of 33,000 ft

LEGEND

- TYPICAL LOW VISIBILITY TAXI ROUTE
- STOP BAR
- CENTERLINE LIGHTING
- CONSTRUCTION AREA

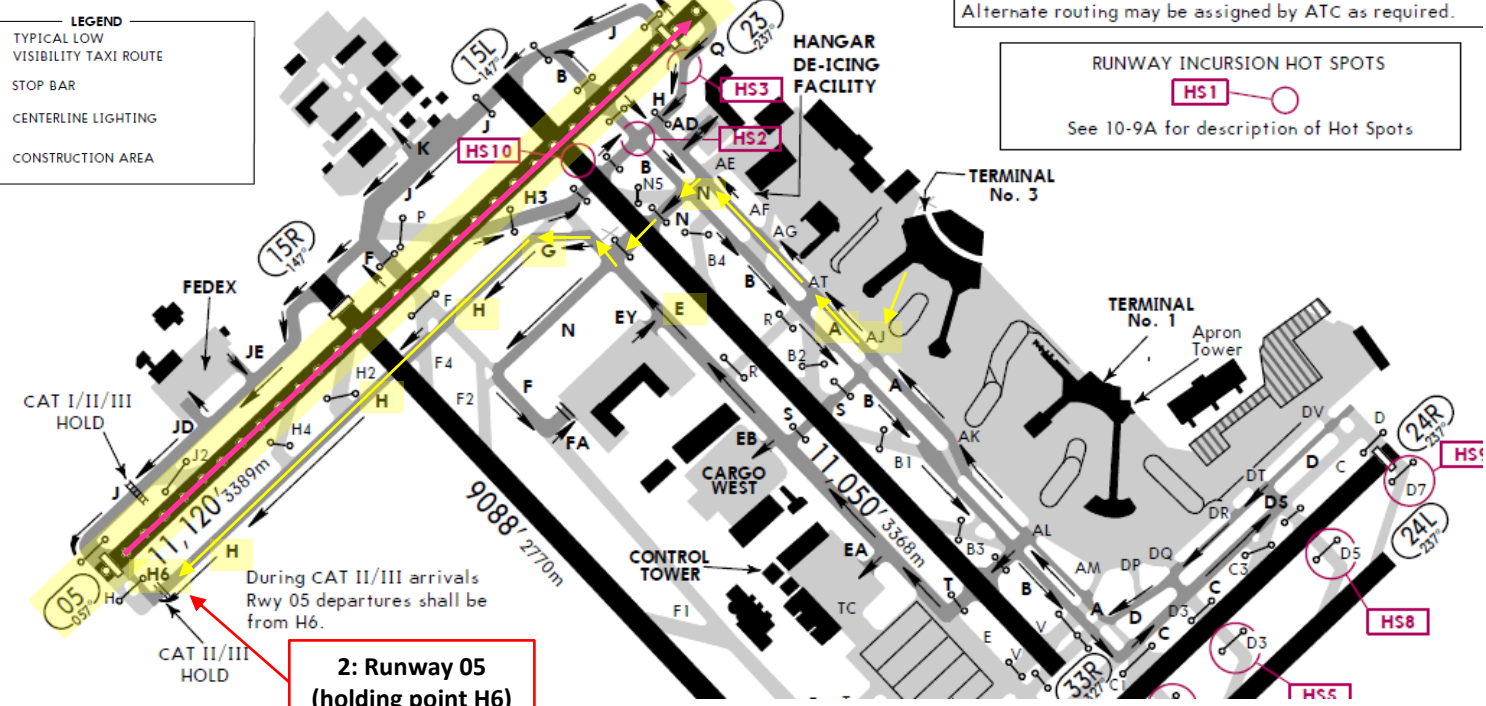

Alternate routing may be assigned by ATC as required.

RUNWAY INCUSSION HOT SPOTS

See 10-9A for description of Hot Spots

JEPPESEN 16 DEC 05 (10-3B) Eff 22 Dec **SID**

TORONTO Departure **127.57 128.8** **TORONTO, ONT TORONTO/PEARSON INTL**

LESTER SEVEN DEPARTURE (LEST7.) (VECTOR)

UNLESS OTHERWISE ASSIGNED BY ATC:
 JET ACFT MAINTAIN 5000', NON-JET ACFT MAINTAIN 3000'
 DO NOT EXCEED 250 KT UNTIL ABOVE 10000'
 (REFER TO NOISE ABATEMENT PROCEDURES FOR ADDITIONAL REQUIREMENTS)

CAUTION: Rwy 05, 06L, 06R, 23, 24L, 24R departures: Simultaneous parallel departures in use.

TURBOJET/FAN AIRCRAFT ONLY

RWY	VNAP
ALL RWYS	A or B

NOISE ABATEMENT
 RWYS 05, 06L, 06R, 23, 24L, 24R DEPARTURES: FOR NOISE ABATEMENT NO UNAUTHORIZED TURNS BELOW 3600' EXCEPT AS DESCRIBED IN NOISE ABATEMENT PROCEDURES (See Chart 10-4A).
 RWY 33L DEPARTURE: FOR NOISE ABATEMENT NO UNAUTHORIZED TURNS BELOW 3600' NOR PRIOR TO MALTN INT. NON-JET AIRCRAFT COMMENCE TURN ASSIGNED AT TAKE-OFF AT 1100' (0700-2300 LOCAL TIME).
DEPARTURE
 Unless otherwise assigned by ATC:
Rwy 05: Climb heading 057°. At 1000' turn LEFT heading 047° or assigned heading for vectors to assigned route. **MAINTAIN 5000'** jet acft, 3000' non-jet acft.
Rwys 06L, 06R: Climb heading 057° or assigned heading for vectors to assigned route. **MAINTAIN 5000'** jet acft, 3000' non-jet acft.
Rwy 23: Climb heading 237°. At YTP 1.9 DME turn RIGHT heading 245° or assigned heading for vectors to assigned route. **MAINTAIN 5000'** jet acft, 3000' non-jet acft.

Rwys 24L, 24R: Climb heading 237°, at YYZ 1.6 DME turn LEFT heading 235° or assigned heading for vectors to assigned route. **MAINTAIN 5000'** jet acft, 3000' non-jet acft.
Rwy 33L: Climb heading 327° to 1100'. Turn RIGHT heading 005° to intercept YYZ R-343 outbound. Track YYZ R-343 outbound for vectors to assigned route. **MAINTAIN 5000'** jet acft, 3000' non-jet acft.

COMMUNICATION FAILURE
 On recognition of a failure 20 minutes or less after take-off and in IFR weather conditions, proceed as follows:
 1. Transponder Mode A/3 7600;
 2. Beyond 10 DME YYZ proceed directly on course;
 3. Do not climb above last assigned altitude for 5 minutes after recognition of failure, then;
 4. Climb to flight plan altitude.

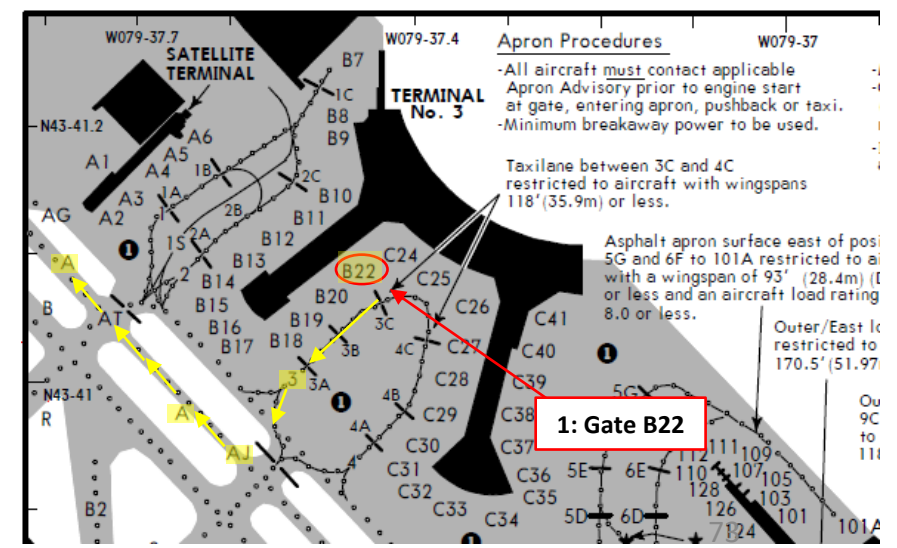
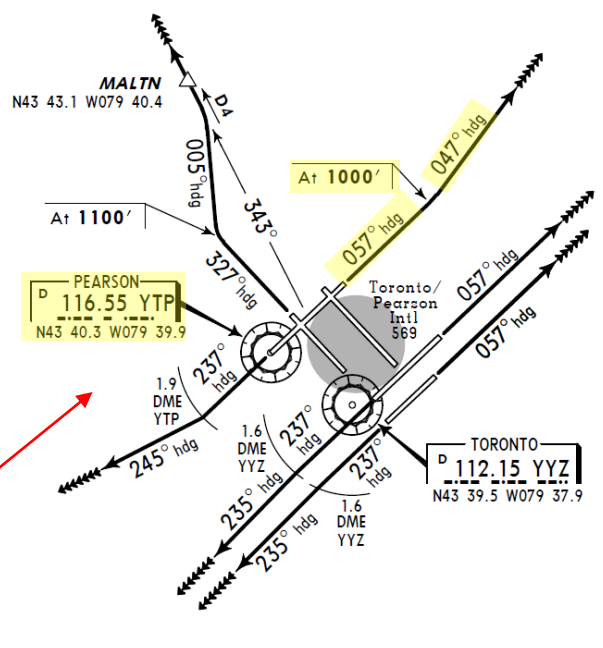

Apron Procedures

-All aircraft must contact applicable Apron Advisory prior to engine start at gate, entering apron, pushback or taxi.
 -Minimum breakaway power to be used.

Taxilane between 3C and 4C restricted to aircraft with wingspans 118'(35.9m) or less.

Asphalt apron surface east of posi 5G and 6F to 101A restricted to aircraft with a wingspan of 93' (28.4m) (or less) and an aircraft load rating 8.0 or less.

Outer/East ILS restricted to 170.5'(51.97m)

PLANNING THE APPROACH - STAR

These charts are for the STAR (Standard Terminal Arrival Route) from PONCT to Boston Logan International Airport (KBOS). This STAR is a little complicated for those not used to land by tracking VORs, so we will simplify it a little. We intend to:

1. Come from PONCT waypoint
2. Fly from PONCT towards the GARDNER FOUR arrival route via PONCT -> ALB.
3. Follow the STAR (ALB -> GDM -> BOS)
4. Follow the approach towards the runway, guided by the KBOS airport's ILS (Instrument Landing System).
5. Land at Boston (KBOS) on runway 22L (orientation: 215 Left)

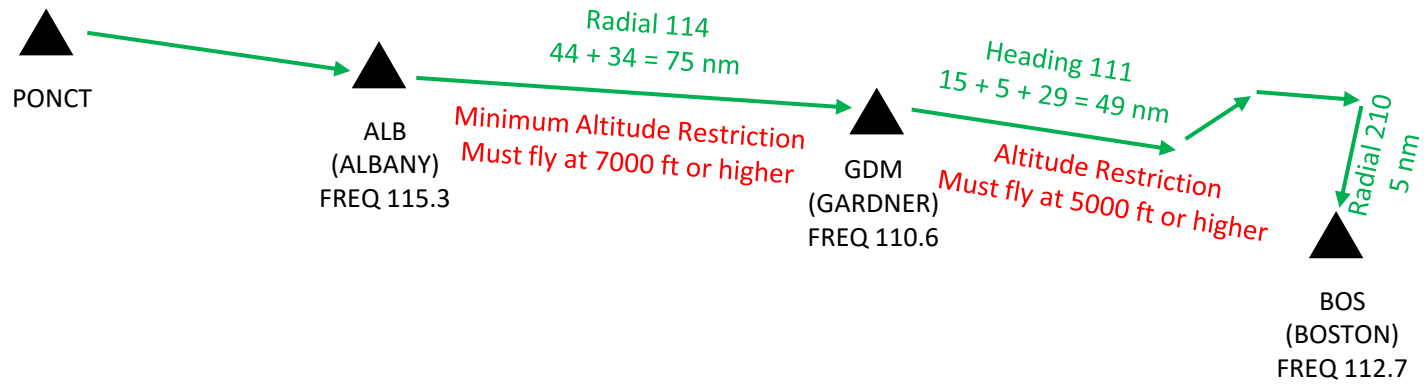
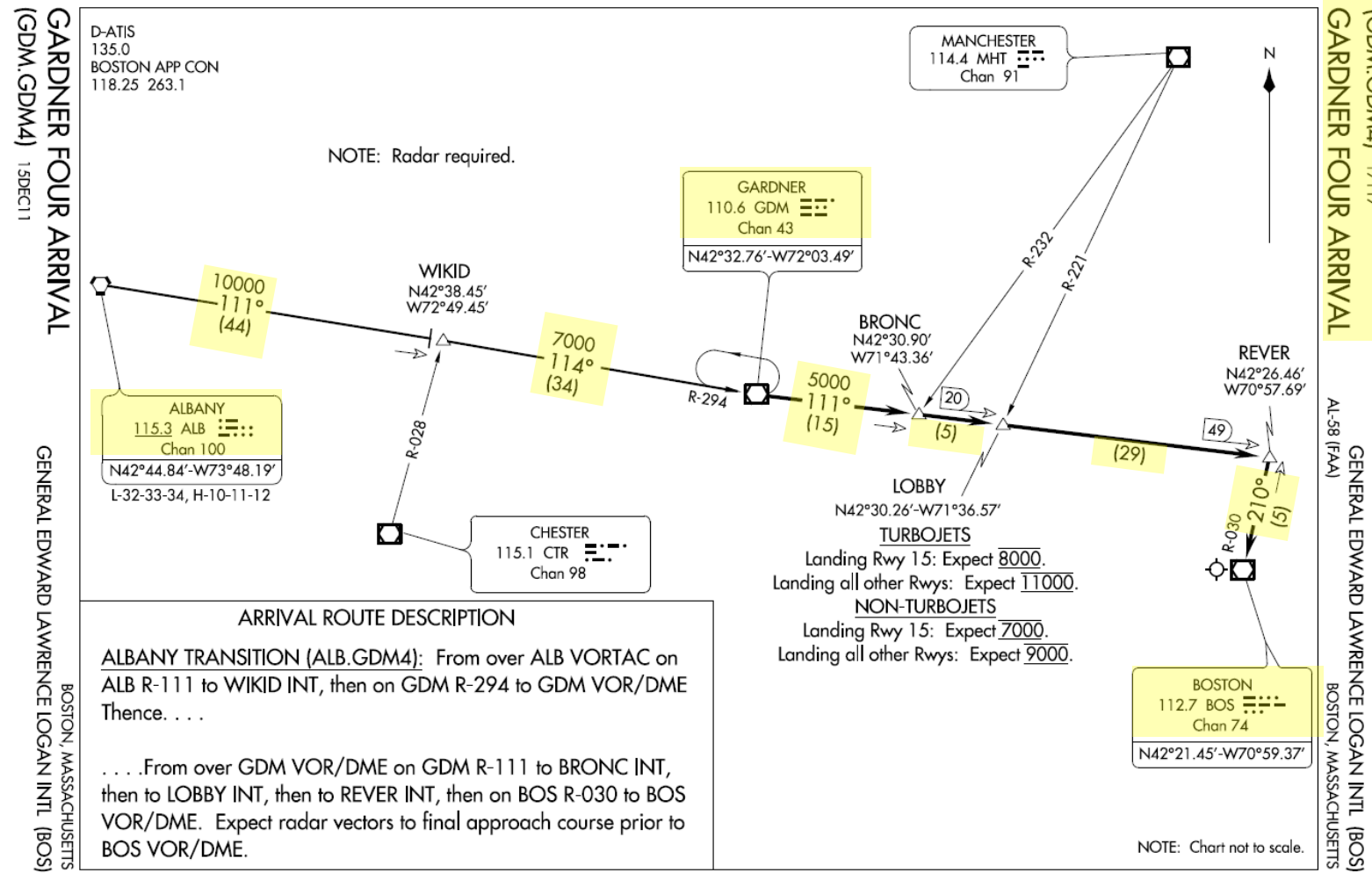

PLANNING THE APPROACH - ILS

These charts are for the ILS approach to Runway 22L for Boston Logan International Airport (KBOS). We intend to:

1. Follow the approach towards the runway, guided by the KBOS airport's ILS (Instrument Landing System) localizer (Freq 110.3) and by the BOSTON VOR (Freq 112.7).
2. Land at Boston (KBOS) on runway 22L (orientation: 215 Left)

AL-58 (FAA) 17285

ILS or LOC RWY 22L

GENERAL EDWARD LAWRENCE LOGAN INTL (BOS)

LOC/DME HGN 110.3 Chan 40	APP CRS 215°	Rwy Idg 8806 TDZE 16 Apt Elev 19			
--	------------------------	---	--	--	--

D-ATIS
135.0
BOSTON APP CON
120.6 263.1
BOSTON TOWER
128.8 257.8
GND CON
121.9
CLNC DEL
121.65 257.8
CPDLC

MISSED APCH FIX
WYANE INT HGN 9.4 RADAR
VOCUS HGN 4.6 RADAR
ZUMOL HGN 1.5 RADAR
ALTERNATE MISSED APCH FIX
114.7 LFV Chan 94
CELTIS LFV 36.7

LOCALIZER 110.3 HGN Chan 40
BOSTON 112.7 BOS Chan 74

ELEV 19 TDZE 16
215° 5.1 NM from FAF

TWR 317
VGSB 112.1 BOS Chan 72
WYANE INT HGN 9.4 RADAR
VOCUS HGN 4.6 RADAR
ZUMOL HGN 1.5 RADAR
WYANE INT HGN 9.4 RADAR

TDZ/CL Rwy 4R, 15R and 33L
REFIL Rwy 4L, 27 and 32
MIRL Rwy 15I-33R
HIRL Rwy 4L-22R, 4R-22L, 9-27, 14-32 and 15R-33L

FAF to MAP 5.1 NM

	Knots	60	90	120	150	180
	Min:Sec	5:06	3:24	2:33	2:02	1:42

BOSTON, MASSACHUSETTS
GENERAL EDWARD LAWRENCE LOGAN INTL (BOS)

Amdt 8C 12OCT17
42°22'N-71°00'W

ILS or LOC RWY 22L

PLANNING THE FLIGHT - SUMMARY

So there it is! This is more or less all the information you need to plan your flight!

SKY VECTOR

<https://skyvector.com/>

CYYZ DCT SIKBO Q140 HANKK Q935 PONCT STAR KBOS

TOTAL FUEL: 27,000 lbs

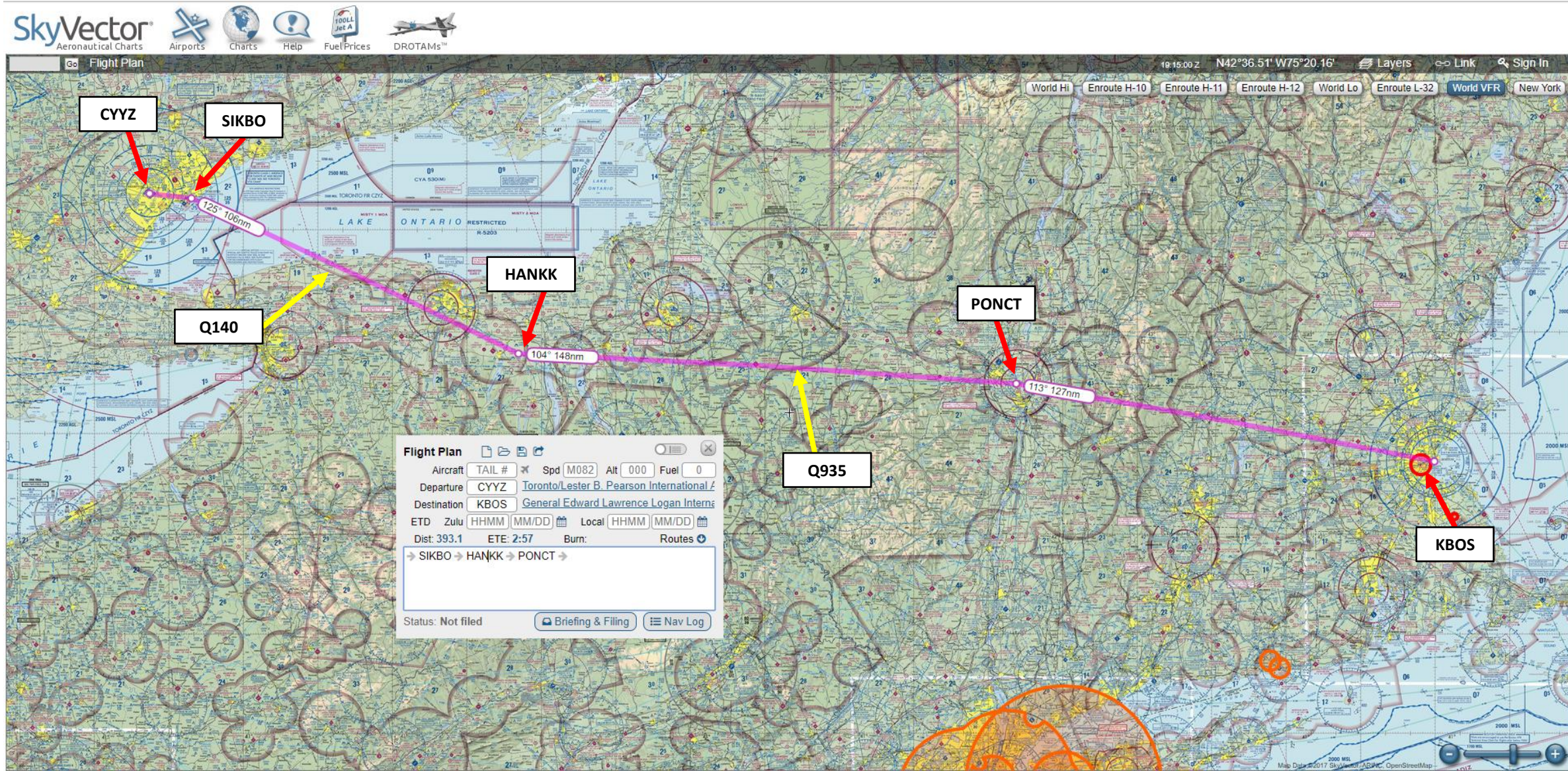

SPAWN IN COLD & DARK STATE

1. Spawn like you normally would at Gate 22 in CYYZ (departure airport) in the Boeing 727-100.
 - a) Select the 727-100
 - b) Click CUSTOMIZE and make sure the “Start with engines running” checkbox is not ticked.
 - c) In the LOCATION menu, type CYYZ and click on Pearson Intl Airport Toronto.
 - d) Click on LOCATION – CUSTOMIZE sub-menu, set the STARTS option to RAMP and select Gate B22.
 - e) Click CONFIRM
 - f) Click START FLIGHT

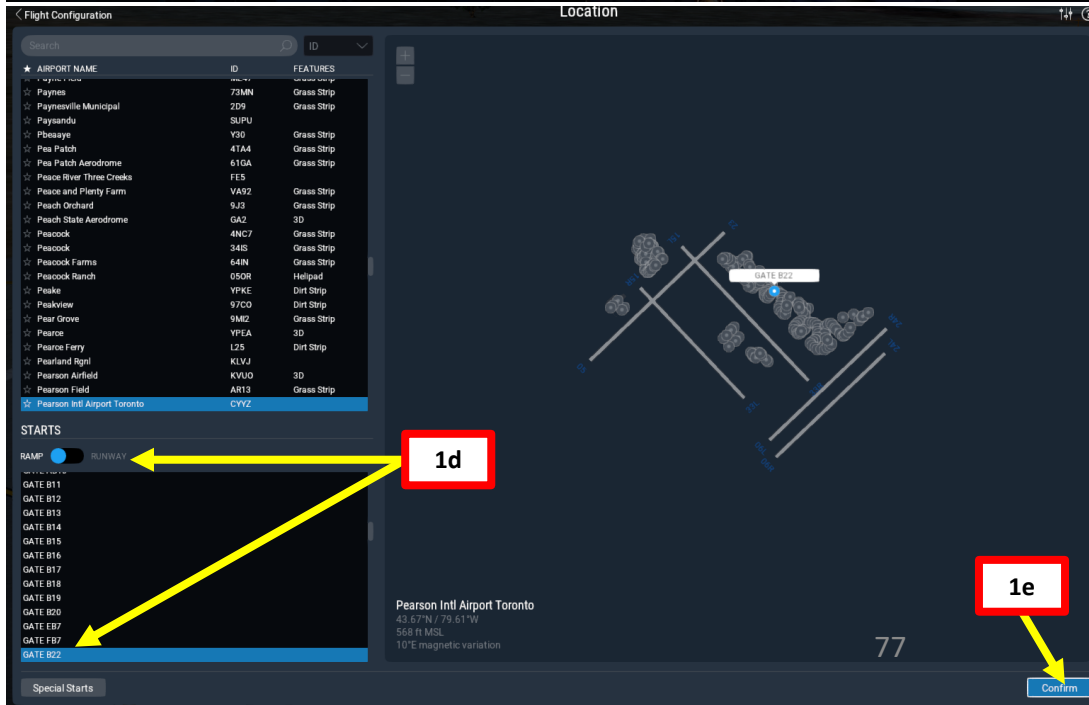
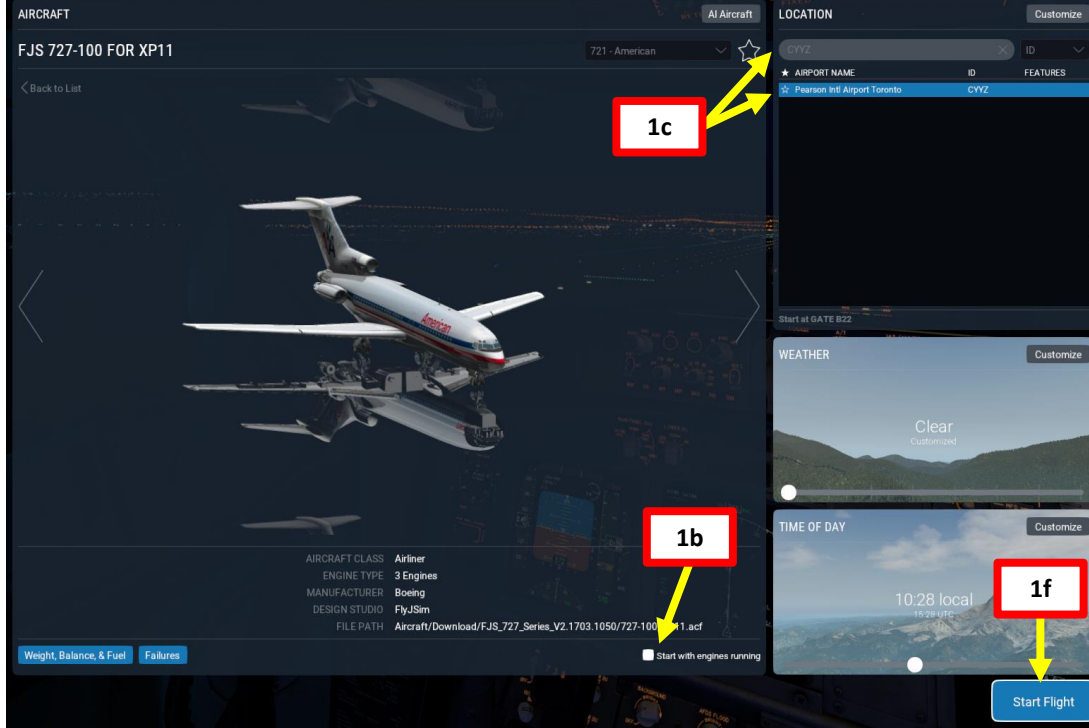
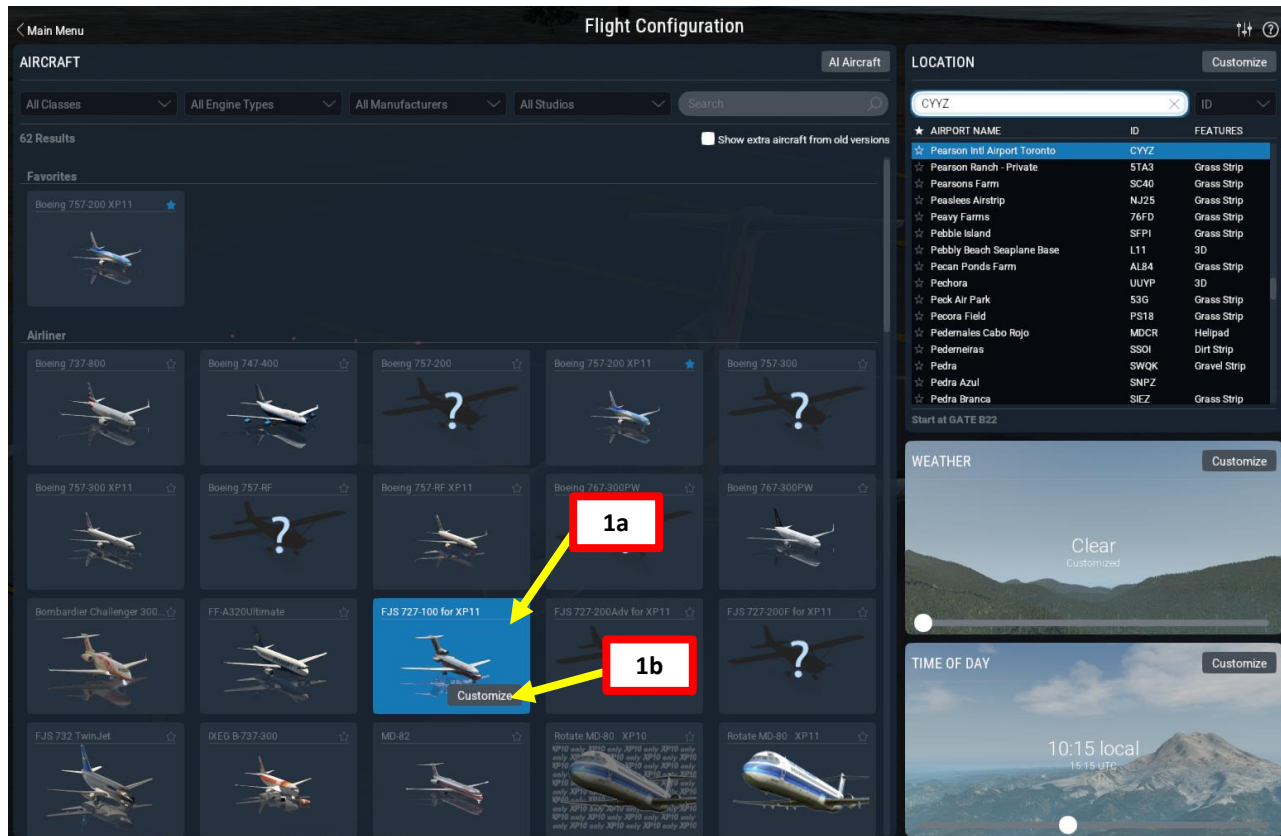

BOARD AIRCRAFT & OPEN DOORS

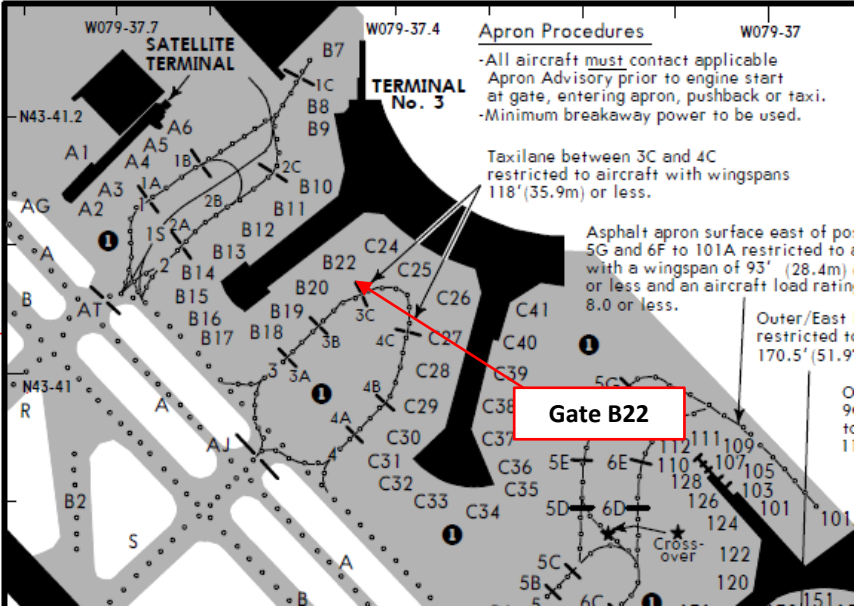

Deploy Rear Boarding Stairs by pressing "LSHIFT+F1"



LOAD FUEL, CARGO & PASSENGERS

Note: Make sure to have all doors open or you will not be able to load passengers and cargo.

We will dynamically set our fuel, cargo and passenger loads using the Weight & Balance Load Manager Control Panel.

- Click on WnB tab
- Set Total Fuel to 27000 lbs by clicking on the + and - buttons. You can fine-tune the fuel load with the Fuel Load per Tank sub-menu.
- Set Passengers by clicking in the blue squares in the First Class and Economy Class sections. We will use a PAX weight of 71 passengers.
- Set Cargo by clicking in the blue squares in the Forward Cargo and Aft Cargo bays. We will use a cargo weight of 6250 lbs.
- Now that we have decided what the aircraft will carry, we have to verify that:
 - The CG (Center of Gravity) location (blue line) is within limits (pink lines). If it isn't, you can shift around the Fuel Load per tank, the Forward/Aft Cargo and the location of passengers within the First Class and Economy Class as shown in steps 3, 4 and 5.
 - The Gross Weight of the aircraft (137,490 lbs) does not exceed Max Takeoff Weight (160,000 lbs).
 - The Landing Weight of the aircraft (115,410 lbs) does not exceed the Max Landing Weight (137,500 lbs)
 - The Zero Fuel Weight of the aircraft (110,419 lbs) does not exceed the Max Zero Fuel Weight (118,000 lbs).
 - The Trip Distance available (1104 nm) is greater than the flight plan distance (391 nm).
- Take note of the resulting Center of Gravity (CG) position. In our case, we have **23.6 % of MAC** (Mean Aerodynamic Chord)
- Once all that is done, you may now close the Weight & Balance tab by clicking the red circle on the Weight & Balance Manager window, and then power up the aircraft!

Weight & Balance

FIRST CLASS ECONOMY CLASS CARGO

Empty Weight	87839 lbs
Pax Weight	16330 lbs (71)
Cargo Hold Weight	6250 lbs
Zero Fuel Weight	110419 lbs
Total Fuel	27080 lbs (50%)
Gross Weight	137490 lbs (46%)
Trip Distance	1104 nm
Landing Weight	115410 lbs
Opt Altitude	FL363
Max Takeoff	160000 lbs
Max Landing	137500 lbs
Max Zero Fuel	118000 lbs

Fuel F E R Pax F E R Cargo F E R

Left Fuel Tank 8190 79% - +

Center Fuel Tank 8870 29% - +

Right Fuel Tank 9990 97% - +

Center of Gravity 23.6% of MAC

Lower CG Limit CG Location Upper CG Limit

Callouts: 2, 4, 4, 4, 5, 6d, 6b, 6e, 6c, 6b, 6c, 6d, 3, 7, 8

POWER UP AIRCRAFT

9. On Overhead panel, turn on battery power
 - a) Set Battery switch to ON (DOWN)
 - b) Lock battery switch by clicking on switch safety guard
10. Set Parking Brake (PULLED AFT = ENGAGED)
11. Set ground power ON
 - a) Click on the Options Sub-Menu button
 - b) Click on the “GPU CART: CONNECTED” button
 - c) Ground crew will now connect ground power to the aircraft. The AC CONNECTED light will illuminate when the GPU (Ground Power Unit) is connected.
 - d) Set EXTERNAL POWER switch to ON to power the aircraft with the GPU.

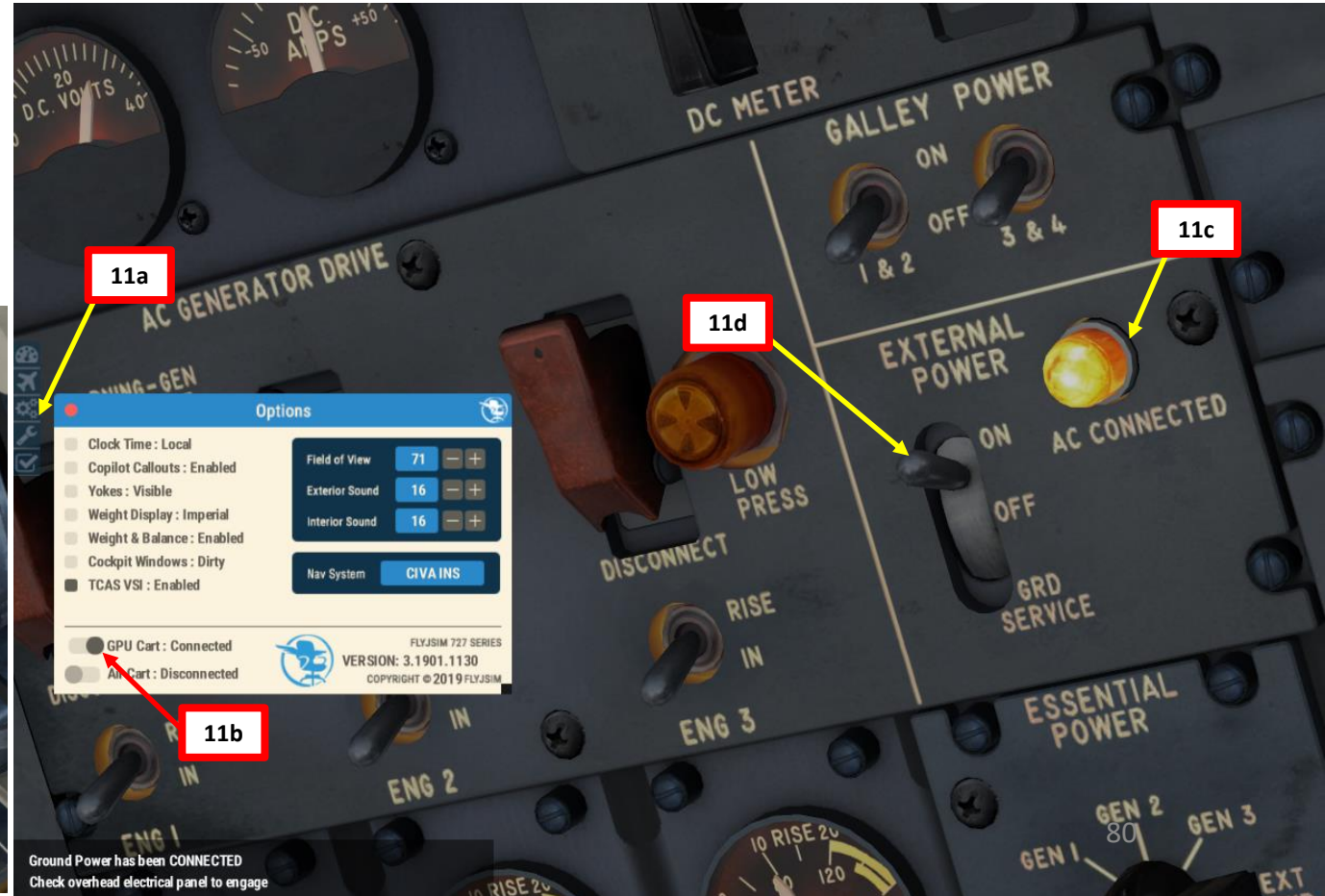
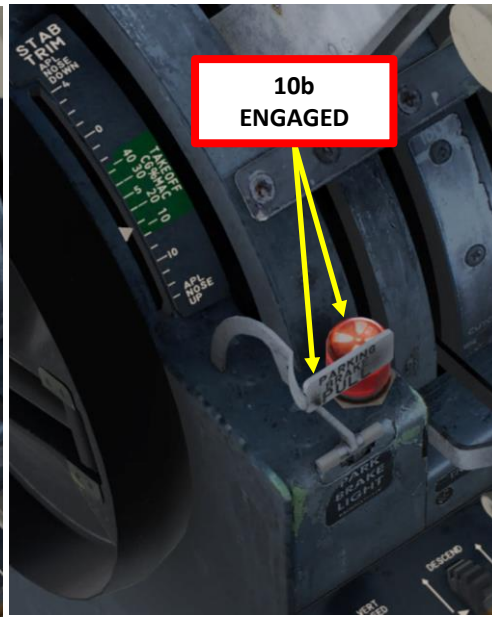
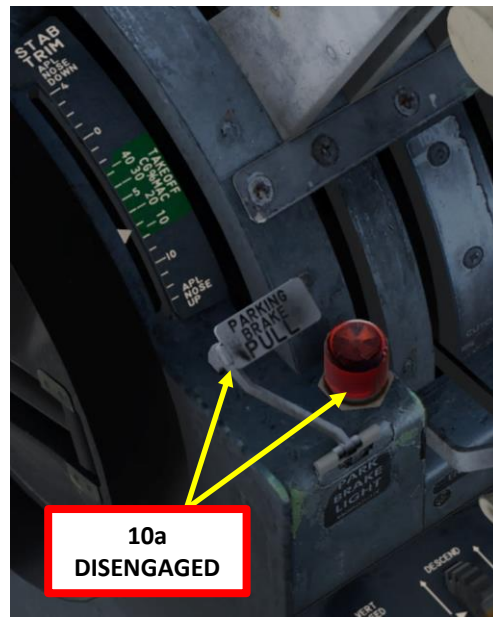
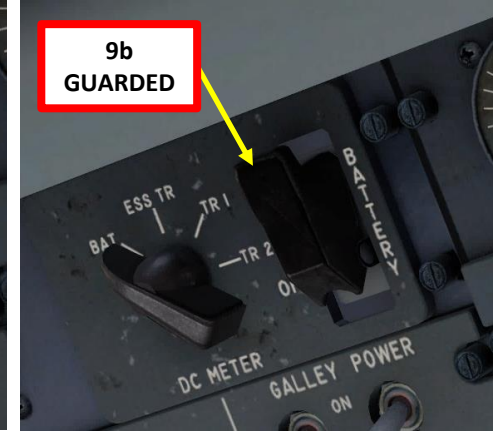

Ground Power has been CONNECTED
Check overhead electrical panel to engage

CIVA SETUP - INSTALLATION

Delco Carousel IV-A Inertial Navigation System (CIVA INS) Panel

The CIVA (Delco Carousel IV-A) is a payware third-party add-on available on the X-Plane store. You need to buy it for 10 \$ in order to use it and install it. Link: http://store.x-plane.org/CIVA-Navigation-System_p_196.html

- 12. Make sure the CIVA system is installed correctly in the following directory:
C:\Program Files\X-Plane\X-Plane 11\Aircraft\Download\727_Series_Pro_V3_-100\plugins\xciva
- 13. The CIVA is actually a plugin that needs to be activated in the Plugin Admin menu since it is de-activated by default.
 - a) Move your cursor in the upper section of the screen to display the Main Menu
 - b) Select the "Plugins -> Plugin Admin -> Enable/Disable" menu
 - c) Find the "CIVA for X-Plane" plugin (click NEXT to cycle plugin pages if required) and make sure it is checked in green. The CIVA plugin will then be activated.
- 14. Click the Options menu and make sure the "CIVA INS" option is selected in the "Nav System" field.

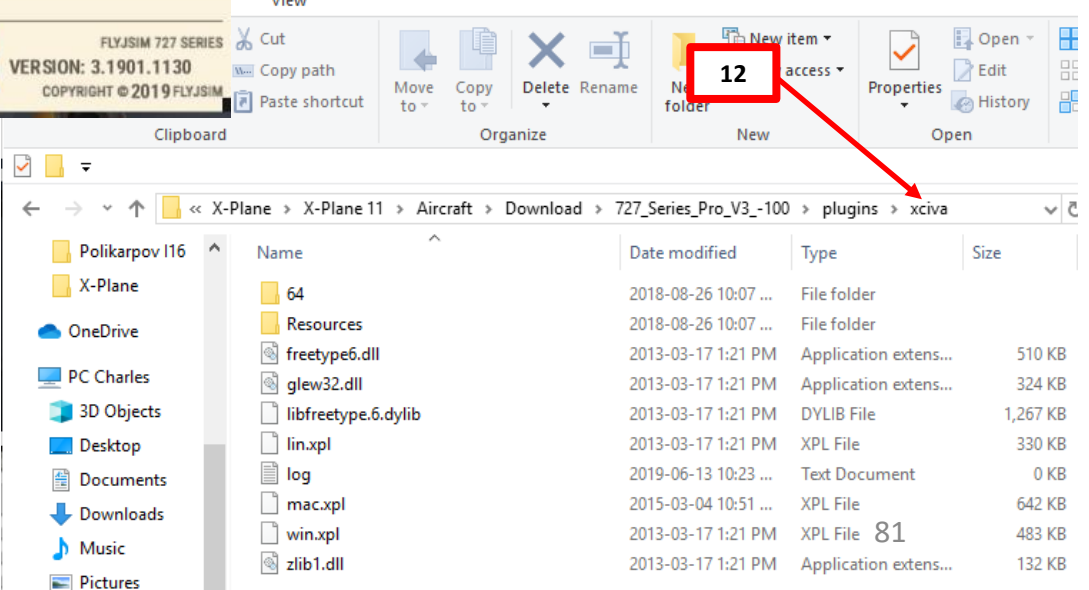
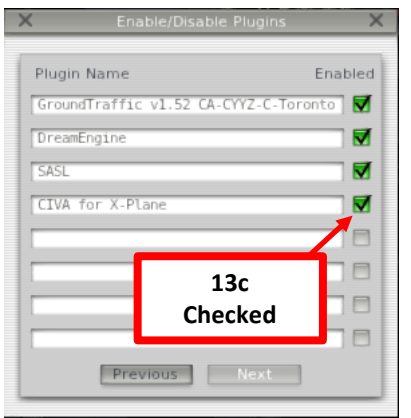
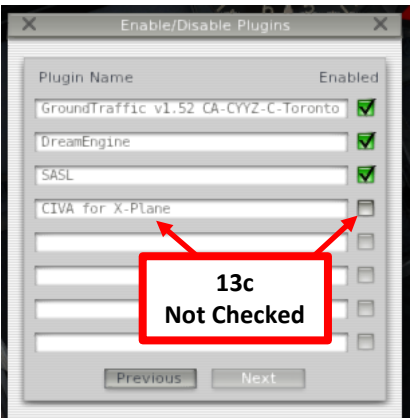
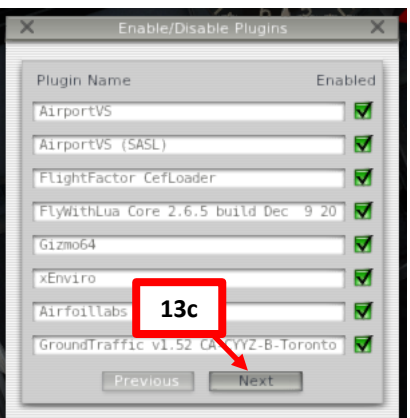
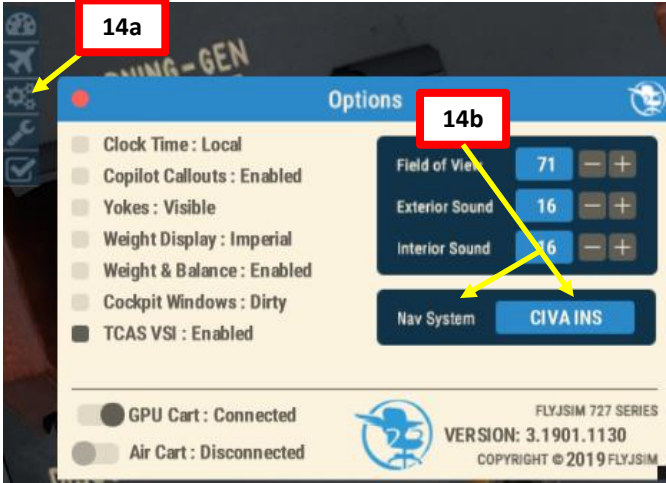
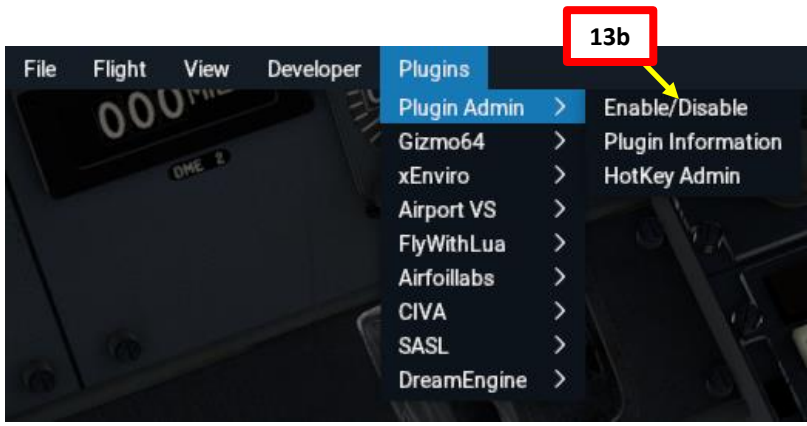

CIVA SETUP – FLIGHT PLAN

15. First, we need to find our current location in the world so the CIVA can have an idea of where we are. Luckily, X-Plane can show us that kind of data.



- a) Move your cursor in the upper section of the screen to display the Main Menu
- b) Click on the SETTINGS icon
- c) Select DATA OUTPUT menu
- d) Make sure the "Latitude, Longitude & Altitude" option is checked and click on DONE
- e) Coordinates of your current position will now be displayed:
LATITUDE: 43.685 deg
LONGITUDE: -79.622 deg

AIRCRAFT COORDINATES
43.69 DEG NORTH, 79.62 DEG WEST

- f) Un-check the "Latitude, Longitude & Altitude" option to hide the coordinates and click on DONE.

Index	Data to Output	Show in Cockpit	Data Graph Window	Disk (data.txt File)	Network via UDP
0	Frame rate	<input type="checkbox"/>	<input type="checkbox"/>	<input type="checkbox"/>	<input type="checkbox"/>
1	Times	<input type="checkbox"/>	<input type="checkbox"/>	<input type="checkbox"/>	<input type="checkbox"/>
2	Sim stats	<input type="checkbox"/>	<input type="checkbox"/>	<input type="checkbox"/>	<input type="checkbox"/>
3	Speeds	<input type="checkbox"/>	<input type="checkbox"/>	<input type="checkbox"/>	<input type="checkbox"/>
4	Mach, VVI, g-load	<input type="checkbox"/>	<input type="checkbox"/>	<input type="checkbox"/>	<input type="checkbox"/>
5	Weather	<input type="checkbox"/>	<input type="checkbox"/>	<input type="checkbox"/>	<input type="checkbox"/>
6	Aircraft atmosphere	<input type="checkbox"/>	<input type="checkbox"/>	<input type="checkbox"/>	<input type="checkbox"/>
7	System pressures	<input type="checkbox"/>	<input type="checkbox"/>	<input type="checkbox"/>	<input type="checkbox"/>
8	Joystick aileron/elevator/rudder	<input type="checkbox"/>	<input type="checkbox"/>	<input type="checkbox"/>	<input type="checkbox"/>
9	Other flight controls	<input type="checkbox"/>	<input type="checkbox"/>	<input type="checkbox"/>	<input type="checkbox"/>
10	Artificial stability	<input type="checkbox"/>	<input type="checkbox"/>	<input type="checkbox"/>	<input type="checkbox"/>
11	Flight controls aileron/elevator/rudder	<input type="checkbox"/>	<input type="checkbox"/>	<input type="checkbox"/>	<input type="checkbox"/>
12	Wing sweep & thrust vectoring	<input type="checkbox"/>	<input type="checkbox"/>	<input type="checkbox"/>	<input type="checkbox"/>
13	Trim, flap, stats, & speedbrakes	<input type="checkbox"/>	<input type="checkbox"/>	<input type="checkbox"/>	<input type="checkbox"/>
14	Gear & brakes	<input type="checkbox"/>	<input type="checkbox"/>	<input type="checkbox"/>	<input type="checkbox"/>
15	Angular moments	<input type="checkbox"/>	<input type="checkbox"/>	<input type="checkbox"/>	<input type="checkbox"/>
16	Angular velocities	<input type="checkbox"/>	<input type="checkbox"/>	<input type="checkbox"/>	<input type="checkbox"/>
17	Pitch, roll, & headings	<input type="checkbox"/>	<input type="checkbox"/>	<input type="checkbox"/>	<input type="checkbox"/>
18	Angle of attack, sideslip, & paths	<input type="checkbox"/>	<input type="checkbox"/>	<input type="checkbox"/>	<input type="checkbox"/>
19	Magnetic compass	<input type="checkbox"/>	<input type="checkbox"/>	<input type="checkbox"/>	<input type="checkbox"/>
20	Latitude, longitude, & altitude	<input checked="" type="checkbox"/>	<input type="checkbox"/>	<input type="checkbox"/>	<input type="checkbox"/>
21	Location, velocity, & distance traveled	<input type="checkbox"/>	<input type="checkbox"/>	<input type="checkbox"/>	<input type="checkbox"/>
22	All planes latitude	<input type="checkbox"/>	<input type="checkbox"/>	<input type="checkbox"/>	<input type="checkbox"/>
23	All planes longitude	<input type="checkbox"/>	<input type="checkbox"/>	<input type="checkbox"/>	<input type="checkbox"/>
24	All planes altitude	<input type="checkbox"/>	<input type="checkbox"/>	<input type="checkbox"/>	<input type="checkbox"/>
25	Throttle (commanded)	<input type="checkbox"/>	<input type="checkbox"/>	<input type="checkbox"/>	<input type="checkbox"/>
26	Throttle (actual)	<input type="checkbox"/>	<input type="checkbox"/>	<input type="checkbox"/>	<input type="checkbox"/>
27	Engine feather, normal, beta, & reverse	<input type="checkbox"/>	<input type="checkbox"/>	<input type="checkbox"/>	<input type="checkbox"/>
28	Propeller setting	<input type="checkbox"/>	<input type="checkbox"/>	<input type="checkbox"/>	<input type="checkbox"/>
29	Mixture setting	<input type="checkbox"/>	<input type="checkbox"/>	<input type="checkbox"/>	<input type="checkbox"/>
30	Carburetor heat setting	<input type="checkbox"/>	<input type="checkbox"/>	<input type="checkbox"/>	<input type="checkbox"/>
31	Cowl flap setting	<input type="checkbox"/>	<input type="checkbox"/>	<input type="checkbox"/>	<input type="checkbox"/>
32	Magneto setting	<input type="checkbox"/>	<input type="checkbox"/>	<input type="checkbox"/>	<input type="checkbox"/>
33	Starter timeout	<input type="checkbox"/>	<input type="checkbox"/>	<input type="checkbox"/>	<input type="checkbox"/>
34	Engine power	<input type="checkbox"/>	<input type="checkbox"/>	<input type="checkbox"/>	<input type="checkbox"/>
35	Engine thrust	<input type="checkbox"/>	<input type="checkbox"/>	<input type="checkbox"/>	<input type="checkbox"/>
36	Engine torque	<input type="checkbox"/>	<input type="checkbox"/>	<input type="checkbox"/>	<input type="checkbox"/>
37	Engine RPM	<input type="checkbox"/>	<input type="checkbox"/>	<input type="checkbox"/>	<input type="checkbox"/>
38	Propeller RPM	<input type="checkbox"/>	<input type="checkbox"/>	<input type="checkbox"/>	<input type="checkbox"/>

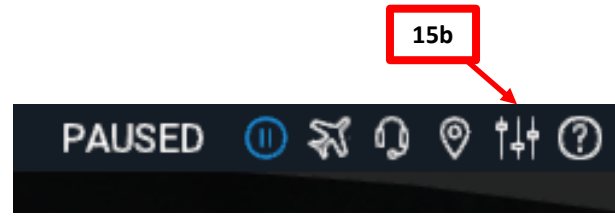

CIVA SETUP – FLIGHT PLAN

16. Next, we need to figure out our waypoint coordinates. Waypoint 0 is our current location (see previous step), which is given in **Decimal Degrees**. However, the CIVA only takes coordinates in **Degrees, Minutes, Tenths of Minutes (DM.m)**. We can use a quick conversion tool (<https://www.directionsmag.com/site/latlong-converter/>) to perform this conversion. Alternatively, you can simply multiply by 60 the decimal part of the Decimal Degrees coordinates to get the Minutes and Tenths of Minutes (M.m) part.

WAYPOINT 0 (CURRENT AIRCRAFT LOCATION):
 LAT/LONG IN DECIMAL DEGREES: **43.69 deg North, 79.62 deg West**
 LAT/LONG IN DEGREES, MINUTES, TENTHS OF MIN: **43°41.4' North, 79°37.2' West**
 LAT/LONG ENTERED IN **CIVA** (FIRST 5 DIGITS ONLY): **43414 North, 079372 West**

17. The rest of the waypoint coordinates are already given in our Flight Plan generated on OnlineFlightPlanner.com, which are given in the **Degrees Minutes Seconds** format, which needs to be converted in Degrees, Minutes, Tenths of Minutes. Feel free to use the conversion tool linked above. Once again, only take the first five digits since the CIVA's precision is limited.

AIRCRAFT COORDINATES (DECIMAL DEGREES)
 43.69 DEG NORTH, 79.62 DEG WEST

AIRCRAFT LOCATION		Decimal Degrees	
Waypoint	Reference	NORTH	WEST
0	CYYZ	49.69	79.62

INPUT TO CIVA		Degrees, Minutes, Tenths of Minutes	
Waypoint	Reference	NORTH	WEST
0	CYYZ	43414	079372
1	SIKBO	43392	079209
2	HANKK	42537	077092
3	PONCT	42448	073488
4	KBOS	42218	071004

Latitude / Longitude Conversion

This page can be used to convert latitude and longitude coordinates.

Deg: Min: Sec:

Degrees: Minutes.M:

Decimal Degrees:

Results:
 DMS 43 41.24
 DM.m 43 41.4
 D.d 43.69

Decimal Degrees

DM.m

The formulas are as follows:

Degrees Minutes Seconds to Degrees Minutes.m
 Degrees = Degrees
 Minutes.m = Minutes + (Seconds / 60)

Degrees Minutes.m to Decimal Degrees
 .d = M.m / 60
 Decimal Degrees = Degrees + .d

Lester B. Pearson International Airport (CYYZ) → General Edward Lawrence Logan International Airport (KBOS)

ID	Frequency	Track	Distance (nm)	Coordinates		Name/Remarks
CYYZ	-	0	0	N43°40'36.18"	W079°37'50.36"	LESTER B. PEARSON INTL
SIKBO	-	101	12	N43°39'13.00"	W079°20'57.00"	SIKBO
RAGIX	-	116	18	N43°32'37.78"	W078°57'26.89"	RAGIX
MEDAV	-	116	9	N43°29'19.00"	W078°45'46.00"	MEDAV
AHPAH	-	116	30	N43°18'19.00"	W078°07'35.11"	AHPAH
HANKK	-	124	49	N42°53'41.82"	W077°09'15.21"	HANKK
JOSSY	-	97	5	N42°53'29.93"	W077°02'36.80"	JOSSY
AUDIL	-	97	26	N42°52'18.74"	W076°26'35.07"	AUDIL
FABEN	-	97	22	N42°51'12.04"	W075°57'07.91"	FABEN
PONCT	-	98	94	N42°44'48.83"	W073°48'48.07"	PONCT
KBOS	-	105	126	N42°21'46.60"	W071°00'23.00"	GENERAL EDWARD LAWRENCE LOGAN

DMS

A waypoint can be enabled/disabled by clicking on it (except first two and last two waypoints).

11 fixes, 391 nm.

Airways:
CYYZ DCT SIKBO Q140 HANKK Q935 PONCT STAR KBOS

CIVA SETUP – FLIGHT PLAN INS ALIGNMENT

18. Enter your current coordinates in the CIVA (Waypoint 0) and begin alignment of the INS (Inertial Navigation System)
- a) Set Mode Selector Knob to STBY (Standby)
 - b) Set Data Selector Switch to POS (Position) and make sure Waypoint Selected is 0
 - c) Press the “N (2)” key to select North Latitude coordinates field of Waypoint 0
 - d) Press “43414” on the keypad, then press the “INSERT” key to enter Latitude coordinates of Waypoint 0.
 - e) Press the “W (4)” key to select the West Longitude coordinates field of Waypoint 0
 - f) Press “079372”, then press the “INSERT” key to enter Longitude coordinates of Waypoint 0.

INPUT TO CIVA		Degrees, Minutes, Tenths of Minutes	
Waypoint	Reference	NORTH	WEST
0	CYYZ	43414	079372
1	SIKBO	43392	079209
2	HANKK	42537	077092
3	PONCT	42448	073488
4	KBOS	42218	071004

CYYZ DCT SIKBO Q140 HANKK Q935 PONCT STAR KBOS

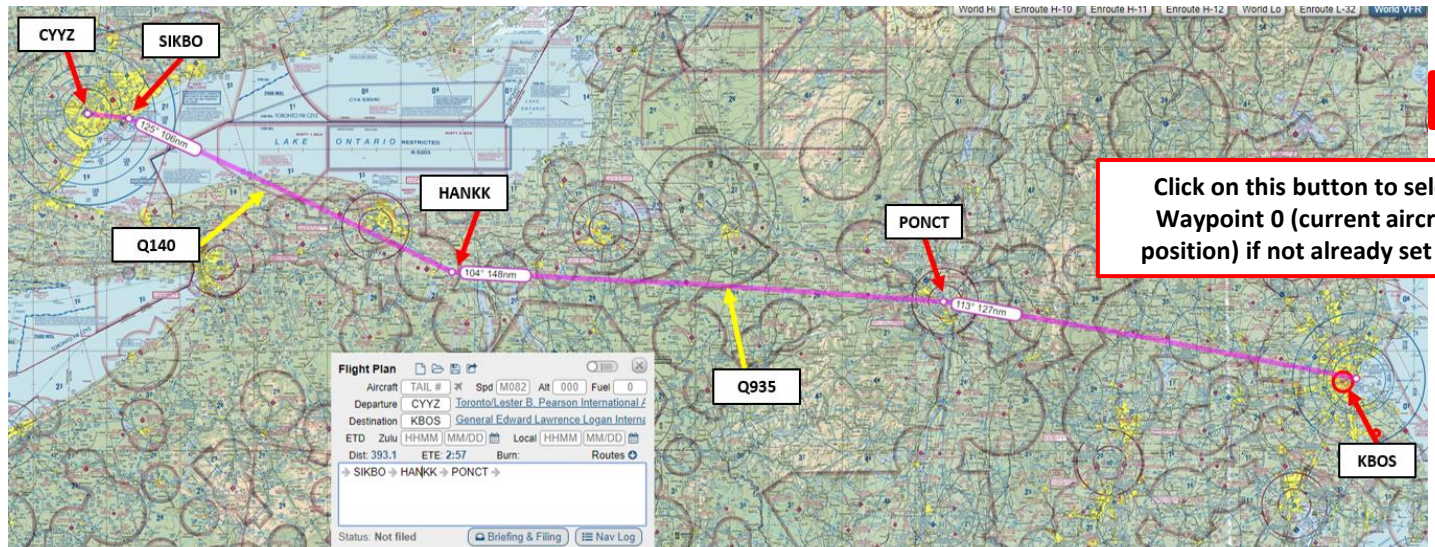

Click on this button to select Waypoint 0 (current aircraft position) if not already set to 0

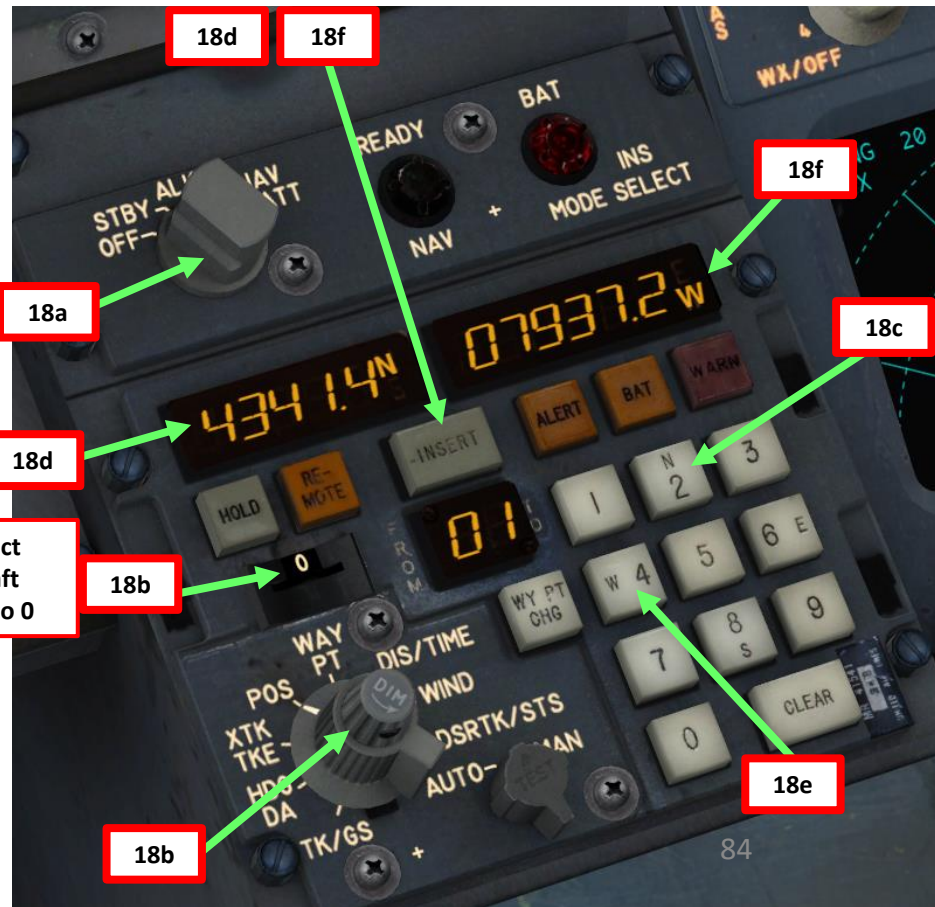

CIVA SETUP – FLIGHT PLAN INS ALIGNMENT

18. Enter your current coordinates in the CIVA (Waypoint 0) and begin alignment of the INS (Inertial Navigation System)
- g) Set Mode Selector Knob to ALIGN to begin INS alignment
 - h) Set Data Selector Switch to DSRTK/STS (Desired Track Angle / Status Code of INS)
 - The code “0 95” should appear once alignment phase has begun.
 - 0 is the Status Code (0 is when Mode is not in NAV, 1 is when Mode is in NAV)
 - 9 is the Actual Performance Index, or how precise the INS is. 9 is the least precise, and 0 is the most precise.
 - 5 is the Desired Performance Index.
 - i) The INS alignment counts down (0 95 is when alignment is starting, 0 55 when coarse alignment is complete, 0 05 when full alignment is complete) until the READY NAV light is illuminated (alignment complete). The next steps can be done while the INS aligning.

INPUT TO CIVA		Degrees, Minutes, Tenths of Minutes	
Waypoint	Reference	NORTH	WEST
0	CYYZ	43414	079372
1	SIKBO	43392	079209
2	HANKK	42537	077092
3	PONCT	42448	073488
4	KBOS	42218	071004

Status Code	Meaning
0 95	Standby INS Warmup. Gyros run up to speed 2 minutes after warmup is completed.
0 85	Coarse Level: Gimbals aligned to the horizontal plane. Battery Unit is tested.
0 75	Coarse Azimuth: Initial Estimate of True North.
0 65	Fine Alignment: Knowledge of True North is refined. Gyros and accelerometers are calibrated.
0 55 to 0 05	Refinement of alignment. The INS Mode Selector may be advanced to NAV at any time during this mode.

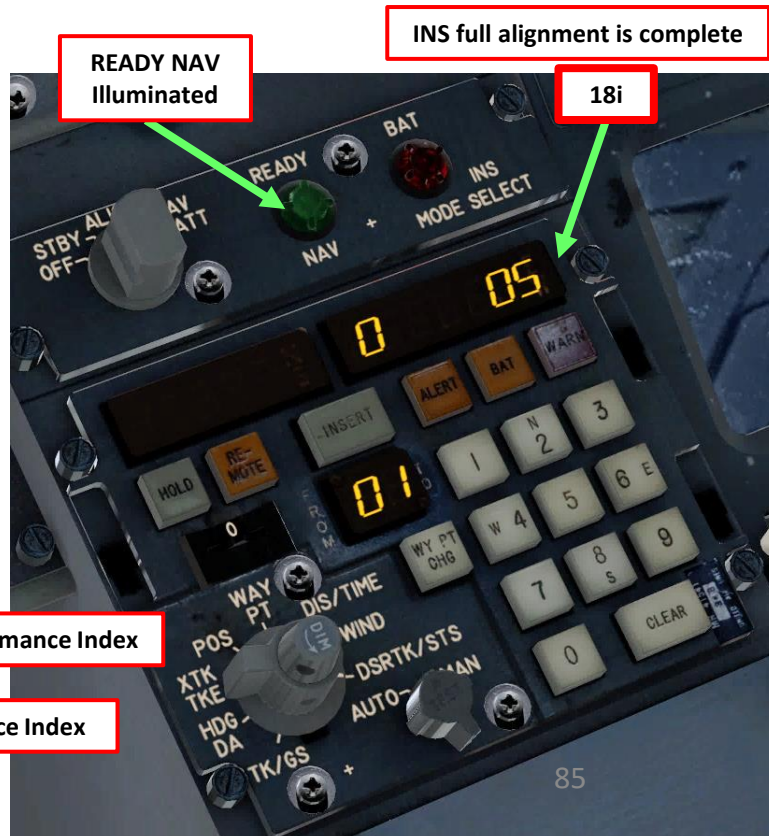
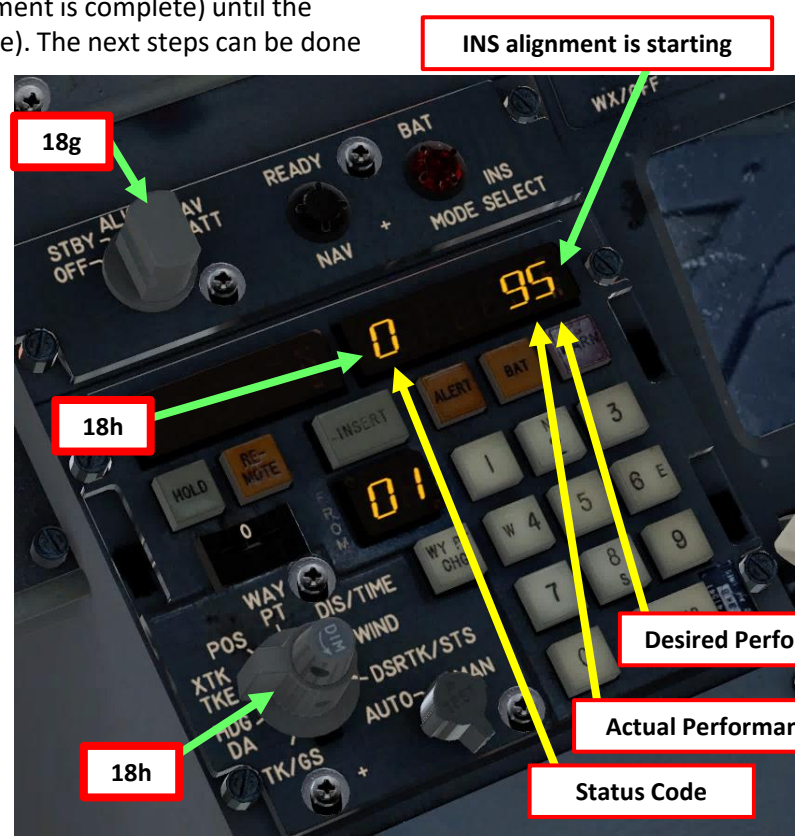

CIVA SETUP – FLIGHT PLAN INS ALIGNMENT

18. Enter your current coordinates in the CIVA (Waypoint 0) and begin alignment of the INS (Inertial Navigation System)
 - j) Set the Data Selector Switch to WAYPT (Waypoint) and select Waypoint 1 SIKBO with the Waypoint Selector Button (reminder: Waypoint 0 is the position of the aircraft).
 - k) Press the “N (2)” key to select North Latitude coordinates field of Waypoint 1
 - l) Press “43392” on the keypad, then press the “INSERT” key to enter Latitude coordinates of Waypoint 1.
 - m) Press the “W (4)” key to select the West Longitude coordinates field of Waypoint 1
 - n) Press “079209”, then press the “INSERT” key to enter Longitude coordinates of Waypoint 1.
 - o) Repeat steps j) through n) for Waypoints 2 (HANKK), 3 (PONCT) and 4 (KBOS).
 - p) Set Mode Selector Knob to NAV when you are done.

INPUT TO CIVA		Degrees, Minutes, Tenths of Minutes	
Waypoint	Reference	NORTH	WEST
0	CYYZ	43414	079372
1	SIKBO	43392	079209
2	HANKK	42537	077092
3	PONCT	42448	073488
4	KBOS	42218	071004

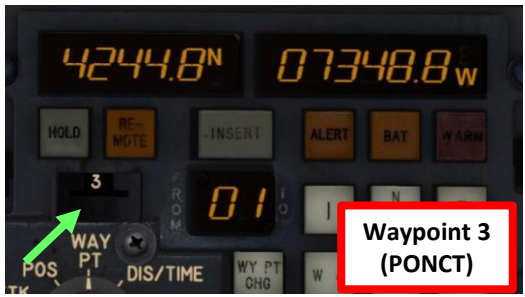
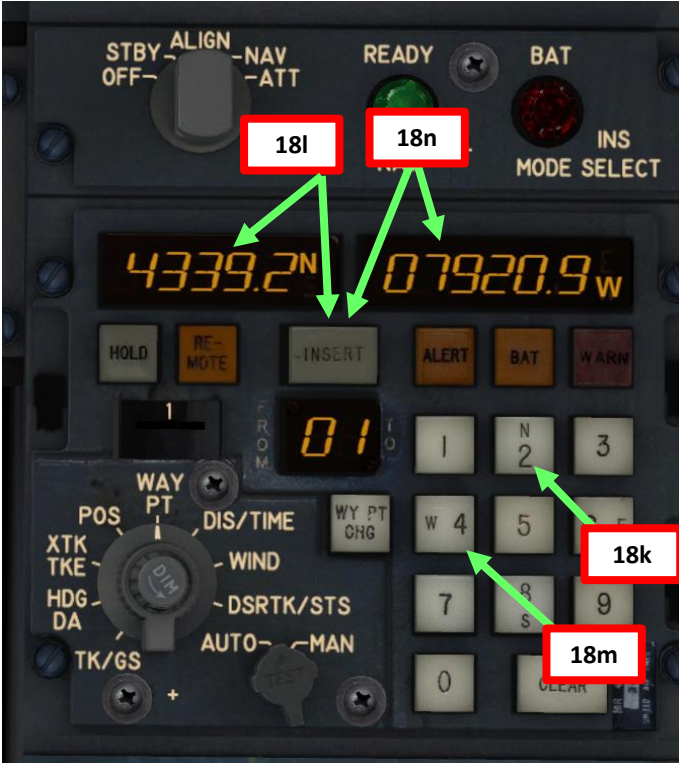
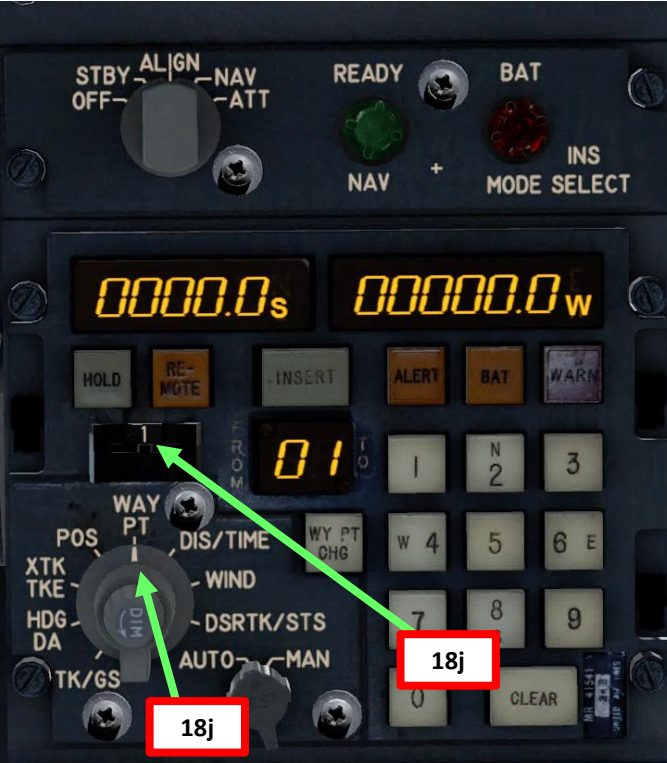

VHF NAV SETUP – DEPARTURE

19. The departure procedure (SID) we intend to take dictates that we depart from runway 05 and follow a heading of 057, then turn to 047 once we reach 1000 ft. We will use the YTP (PEARSON) VOR as a reference.

- a) Set VHF-1 NAV frequency to the frequency of the YTP VOR (116.55 as shown on the Jeppesen chart).
- b) Verify that the TFR switch is set properly, showing that the active frequency is 116.55.
- c) Set GPS/NAV Selector switch to NAV
- d) We can see on the HSI (Horizontal Situation Indicator) that we are 1 nm from the VOR (which is right next to the airport).
- e) Set the HSI VOR Course to 057.
- f) Set the RMI (Radio Magnetic Indicator) VOR/ADF 1 knob to VOR



JEPPESEN 16 DEC 05 (10-3B) Eff 22 Dec **SID**
TORONTO, ONT
 TORONTO Departure **127.57 128.8** **TORONTO/PEARSON INTL**

LESTER SEVEN DEPARTURE (LEST7.) (VECTOR)
 UNLESS OTHERWISE ASSIGNED BY ATC:
 JET ACFT MAINTAIN 5000', NON-JET ACFT MAINTAIN 3000'
 DO NOT EXCEED 250 KT UNTIL ABOVE 10000'
 (REFER TO NOISE ABATEMENT PROCEDURES FOR ADDITIONAL REQUIREMENTS)

CAUTION: Rwy 05, 06L, 06R, 23, 24L, 24R departures: Simultaneous parallel departures in use.

TURBOJET/FAN AIRCRAFT ONLY

RWY	VNAP
ALL RWYS	A or B

NOISE ABATEMENT
 RWYS 05, 06L, 06R, 23, 24L, 24R DEPARTURES: FOR NOISE ABATEMENT NO UNAUTHORIZED TURNS BELOW 3600' EXCEPT AS DESCRIBED IN NOISE ABATEMENT PROCEDURES (See Chart 10-4A).
RWY 33L DEPARTURE: FOR NOISE ABATEMENT NO UNAUTHORIZED TURNS BELOW 3600' NOR PRIOR TO MALTN INT. NON-JET AIRCRAFT COMMENCE TURN ASSIGNED AT TAKE-OFF AT 1100' (0700-2300 LOCAL TIME).
DEPARTURE
 Unless otherwise assigned by ATC:
Rwy 05: Climb heading 057°. At 1000' turn LEFT heading 047° or assigned heading for vectors to assigned route. **MAINTAIN 5000'** jet acft, 3000' non-jet acft.
Rwys 06L, 06R: Climb heading 057° or assigned heading for vectors to assigned route. **MAINTAIN 5000'** jet acft, 3000' non-jet acft.
Rwy 23: Climb heading 237°. At YTP 1.9 DME turn RIGHT heading 245° or assigned heading for vectors to assigned route. **MAINTAIN 5000'** jet acft, 3000' non-jet acft.

Rwys 24L, 24R: Climb heading 237°, at YYZ 1.6 DME turn LEFT heading 235° or assigned heading for vectors to assigned route. **MAINTAIN 5000'** jet acft, 3000' non-jet acft.
Rwy 33L: Climb heading 327° to 1100'. Turn RIGHT heading 005° to intercept YYZ R-343 outbound. Track YYZ R-343 outbound for vectors to assigned route. **MAINTAIN 5000'** jet acft, 3000' non-jet acft.

COMMUNICATION FAILURE
 On recognition of a failure 20 minutes or less after take-off and in IFR weather conditions, proceed as follows:
 1. Transponder Mode A/3 7600;
 2. Beyond 10 DME YYZ proceed directly on course;
 3. Do not climb above last assigned altitude for 5 minutes after recognition of failure, then;
 4. Climb to flight plan altitude.

SID towards next waypoint

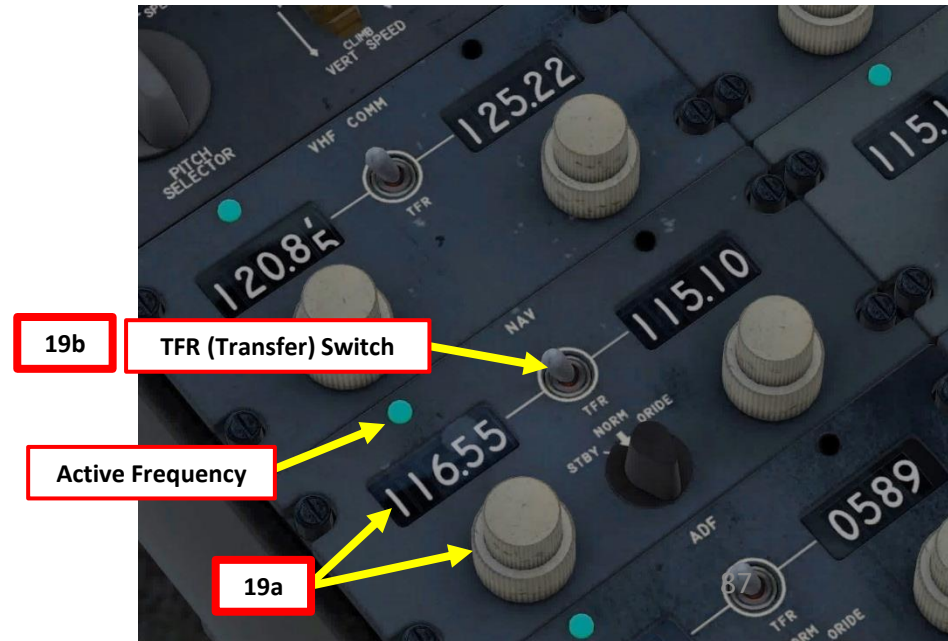
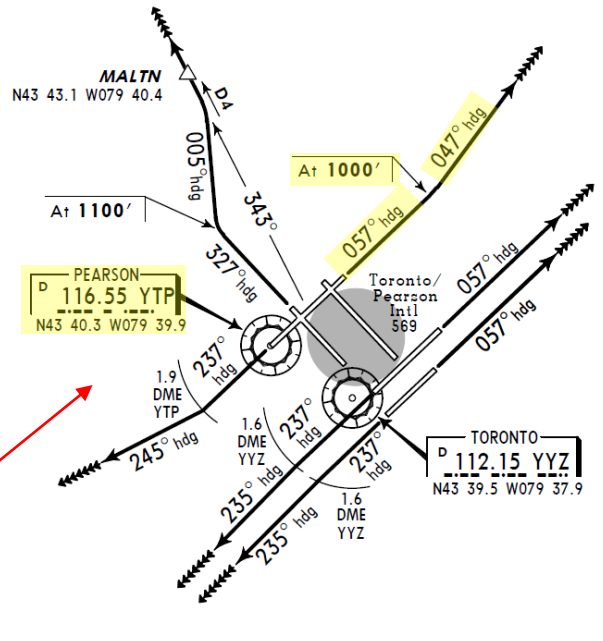

TAKEOFF REF V-SPEEDS

20. If you click on the "V card" sub-menu button, you will get your takeoff & landing reference V-Speeds. You will notice that the airspeed bugs are automatically set on your airspeed indicator.

V₁ is the Decision Speed (minimum airspeed in the takeoff, following a failure of the critical engine at VEF, at which the pilot can continue the takeoff with only the remaining engines), **V_R** is the rotation speed (airspeed at which the pilot initiates rotation to obtain the scheduled takeoff performance), and **V₂** is Takeoff Safety Speed (minimum safe airspeed in the second segment of a climb following an engine failure at 35 ft AGL).

All these V-speeds are computed by FlyJSim for you. In real life, pilots had to figure out the V-speeds themselves by using charts and a bit of math. Modern-day FMCs (Flight Management Computers) compute these speeds in a similar fashion, taking the aircraft's weight, takeoff flap setting and other parameters.

Here are a couple of rule of thumbs to calculate them yourself if you feel like it:

<https://www.boeing-727.com/Data/fly%20odds/thumb.html>

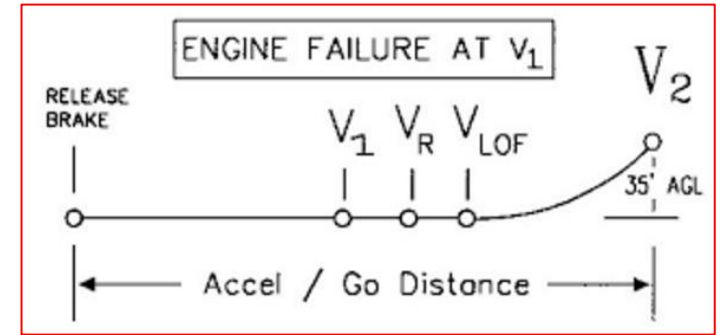

20

TAKEOFF			LANDING		
727					
2.15					
NORMAL EPR	REDUCED EPR	GO-AROUND EPR			
97.4					
NORMAL N ₁	REDUCED N ₁	GO-AROUND N ₁			
	V ₁ 113	INITIAL CLIMB EPR			
20		FLAP RETRACT/ MAN. SPEEDS			
FLAPS	V _R 113	20/15	135		
5.15		5	155		
STAB TRIM	V ₂ 125	2	190		
		0	200		
DUMP TIME					
ZFW 109039	FUEL 24961	T.O. GWT 133999			
TEMP 10	QNH 30.16	PA			
CG					
FLT/TRIP NO.		DATE			

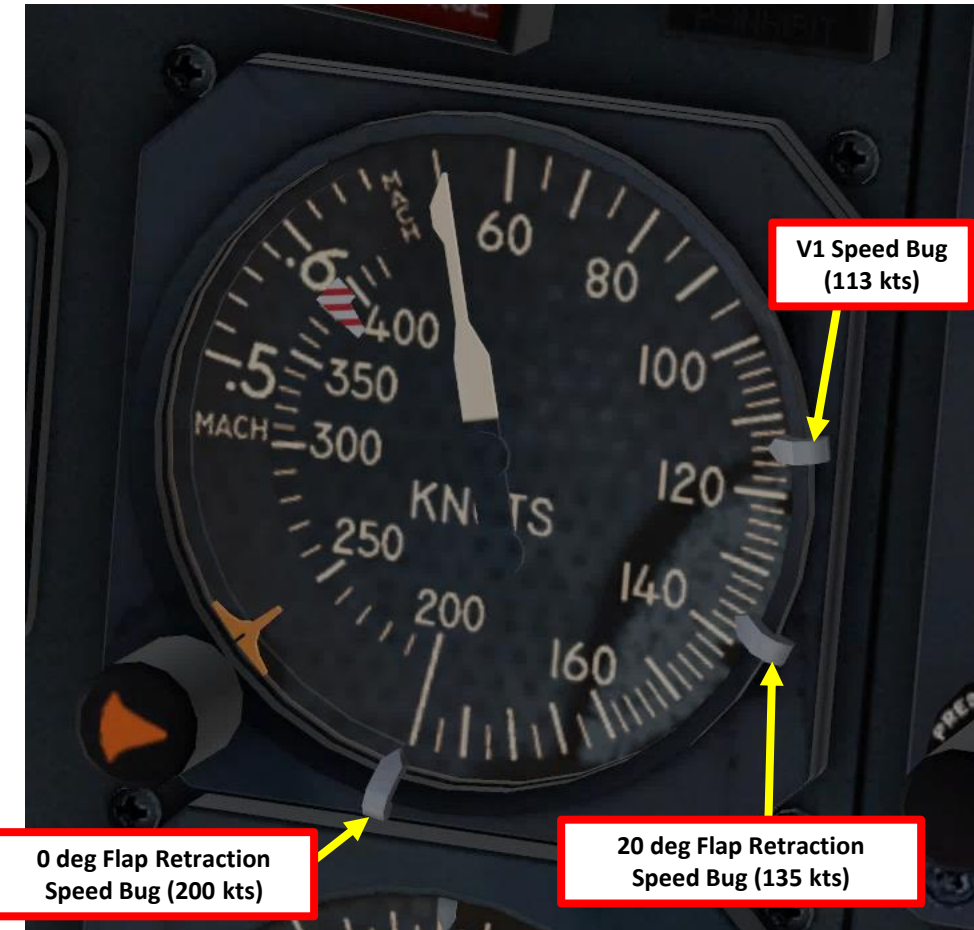

TAKEOFF TRIM & AUTOPILOT SETUP

21. Set Stabilizer (Elevator) trim to the Takeoff Stabilizer Trim setting obtained on the V-Card (5.15). This value is automatically computed.
22. Set up Autopilot for departure
 - a) Set ALTITUDE SELECT to 5000 ft with the black knob, which will be our first altitude target for the initial climb segment
 - b) Set Airspeed Bug to the Initial Climb Speed, which will be $V_2 + 20$ ($125 + 20 = 145$ kts)
 - c) Set the Heading Bug to the Runway Heading (057)

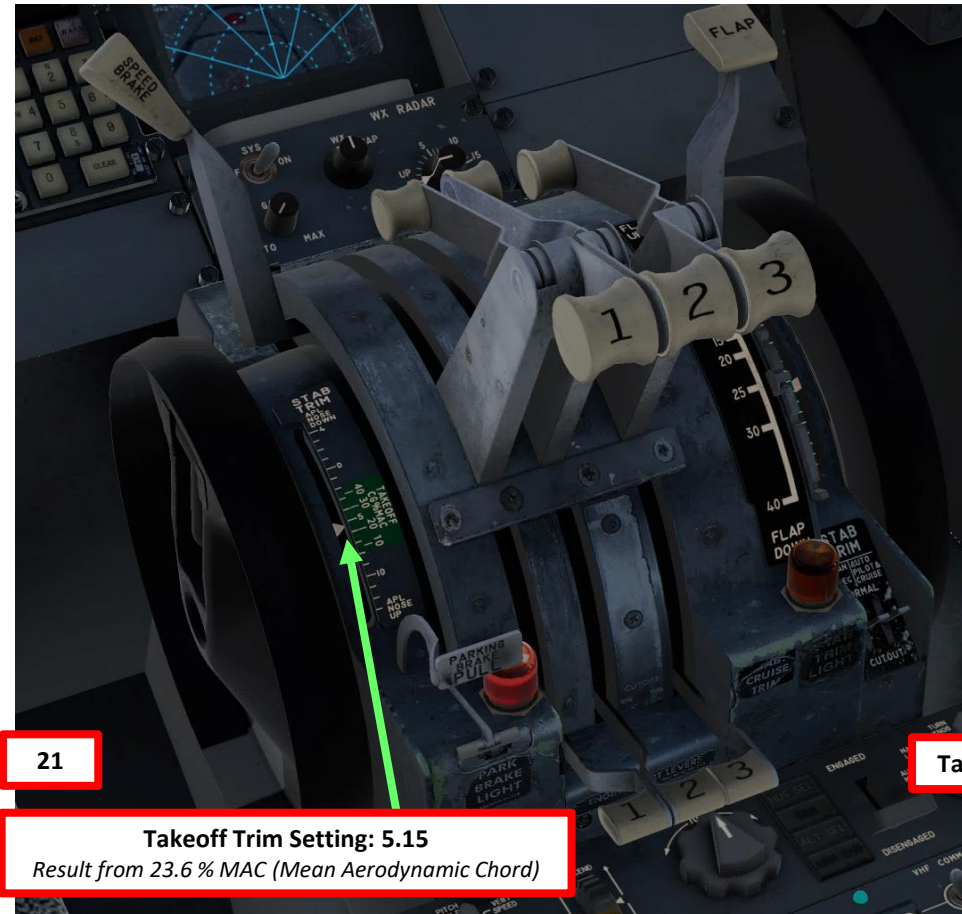
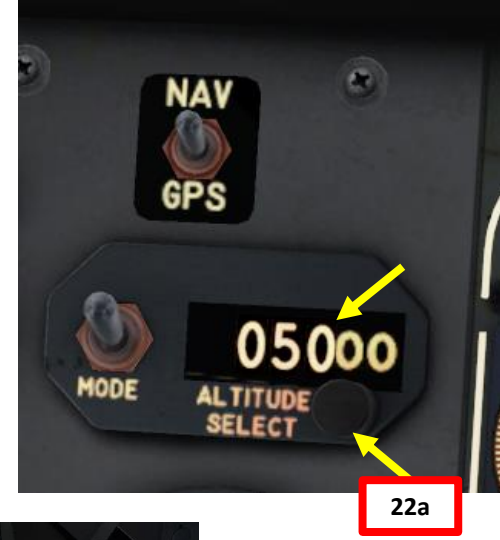

TAKEOFF		LANDING	
727			
<u>2.15</u>	NORMAL EPR	REDUCED EPR	GO-AROUND EPR
<u>97.4</u>	NORMAL N_1	REDUCED N_1	GO-AROUND N_1
<u>20</u>	FLAPS	V_1 <u>113</u>	INITIAL CLIMB EPR
<u>5.15</u>	STAB TRIM	V_R <u>113</u>	FLAP RETRACT/ MAN. SPEEDS
		V_2 <u>125</u>	20/15 <u>135</u>
			5 <u>155</u>
			2 <u>190</u>
			0 <u>200</u>
DUMP TIME			
ZFW <u>109039</u>	FUEL <u>24961</u>	T.O. GWT <u>133999</u>	
TEMP <u>10</u>	QNH <u>30.16</u>	PA	CG
FLT/TRIP NO.	DATE		

21

Takeoff Trim Setting: 5.15
Result from 23.6 % MAC (Mean Aerodynamic Chord)

Takeoff Stab Trim Setting

ALTIMETER SETTING

23. Consult the CYYZ (Toronto) ATIS system via the radio to get the altimeter setting.
- Consult the CYYZ chart and find the Toronto Pearson ATIS Frequency (120.825).
 - Set VHF-1 COMM ACTIVE radio frequency ATIS frequency (120.825). Active frequency is indicated with a small blue light. Due to some minor X-Plane quirk, in our case we had to set the frequency to 120.80 instead of 120.825 to hear the ATIS properly.
 - You should receive the ATIS automated report on the radio for Niagara Falls. The reported altimeter setting is 30.12 inches of Hg.
 - You can click on the TFR (Transfer) button to set the ATIS frequency to the STANDBY frequency once you have the information you need. You will then stop hearing the ATIS broadcast.
24. Set altimeter setting to 3012 (30.12 inches of mercury) by rotating the altimeter and standby altimeter knob. You will see that the altimeter will indicate the airport's elevation, which is approximately 570 ft.

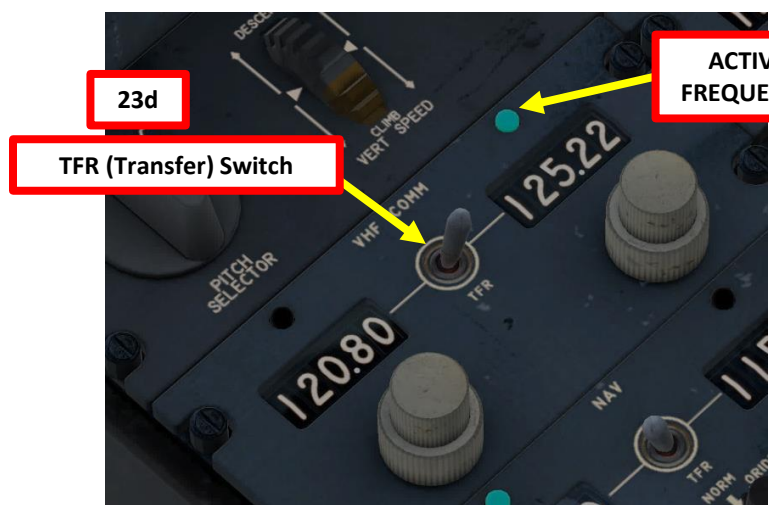

Airport Information
CYYZ (Toronto/Pearson Intl)

JEPPESEN
JeppView 3.5.2.0

Communications Info

ATIS 120.825
 Toronto Tower Tower 118.7
 Toronto Tower Tower 118.35
 Toronto Ground Ground Control 121.9
 Toronto Ground Ground Control 121.66
 Toronto Ground Ground Control 119.1
 Toronto Ground Ground Control 118.0
 Terminal 3 Ramp/Taxi Control 122.875
 South Apron Ramp/Taxi Control 122.075
 North Apron Ramp/Taxi Control 122.275
 Toronto Clearance Delivery Clearance Delivery 121.3
 Toronto Arrival Arrival Control 132.8 Arrival Service
 Toronto Arrival Arrival Control 125.4 Arrival Service
 Toronto Arrival Arrival Control 124.475 Arrival Service
 Toronto Departure Departure Control 128.8 Departure Service
 Toronto Departure Departure Control 127.575 Departure Service
 Toronto Terminal Unknown 133.4
 Toronto Terminal Unknown 119.3
 London Radio Radio 123.275 Flight Info Service RCO
 Skyservice/Esso Aviat Operations 128.95
 Skycharter Ltd Operations 129.75
 Shell Aerecentre Operations 122.95

General Info

0 NM W of Toronto ON, CAN
 N 43° 40.6' W 79° 37.8' Mag Var: 10.4°W
 Elevation: 569'
 Detroit Sectional

NIAGARA FALLS INTL Information leema. 14 hundred zulu weather. Wind light and variable, visibility more than 10. Sky clear, Temperature 19, dewpoint minus 11. Altimeter 3012. Arriving runways 28 right, 28 left, departing runways 28 right, 28 left, 24. Advise on initial contact you have leema.

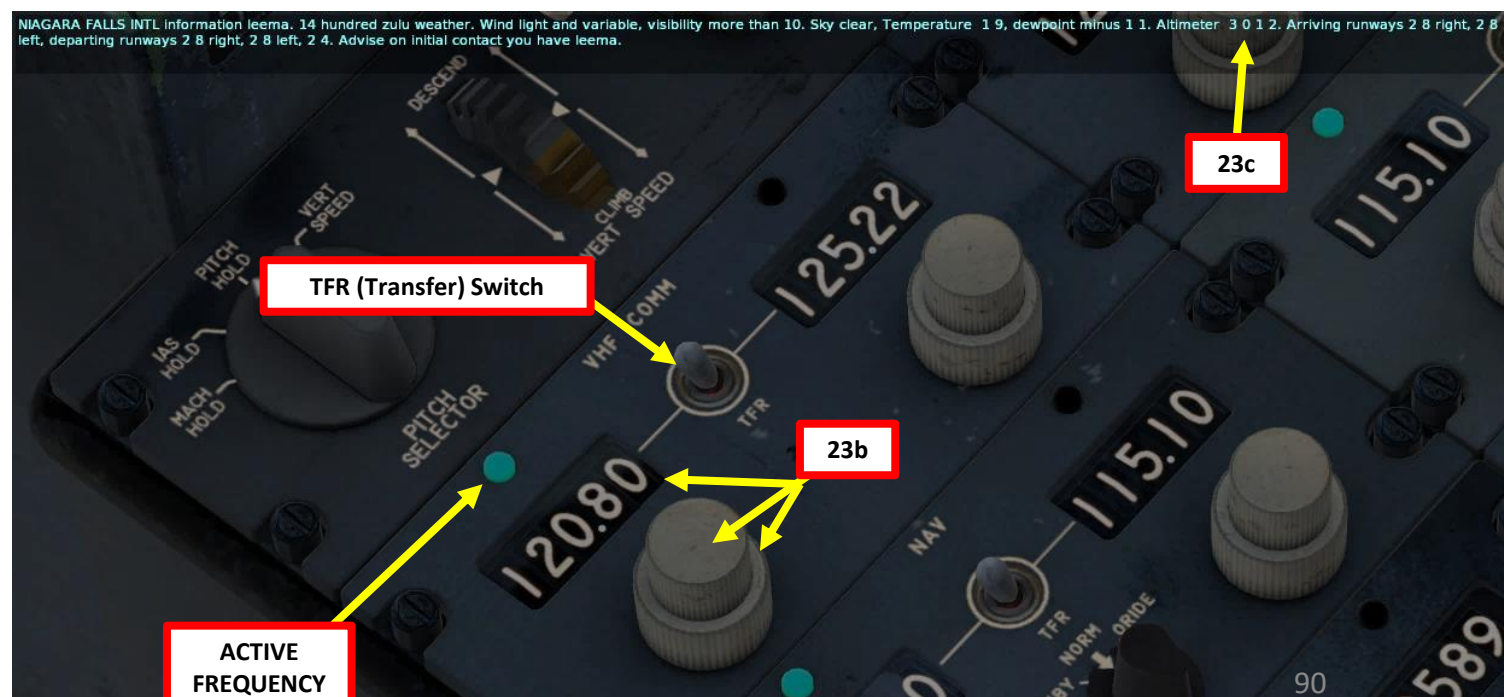

CABIN PRESSURE

25. On the Flight Engineer Panel, set Cabin Pressure Switch to GROUND
26. Set Cabin Pressurization Mode Selector to AUTO
27. Set FLT ALT (Flight Altitude) to our cruising altitude of 33000 ft
28. Set LAND ALT (Landing Altitude) to the Boston Logan Airport's elevation (19 ft, or close to 20 ft)
29. Set Control Cabin Temperature Selector knob to AUTO
30. Set Passenger Cabin Temperature Selector to AUTO
31. Press and hold both COOLING DOORS switches to CLOSE until the cooling doors are completely closed.
32. Set Left and Right A/C PACK (Pneumatic Air Conditioning Kit) switches to OFF
33. Set Gasper Fan switch to OFF

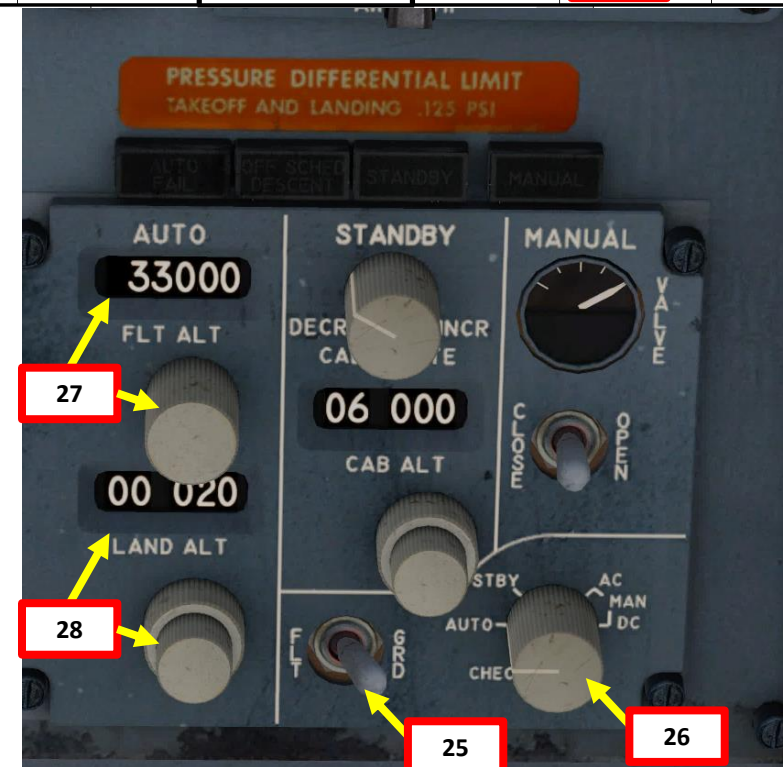

BOSTON, MASSACHUSETTS				AL-58 (FAA)		18088
LOC/DME I-BOS 110.3 Chan 40	APP CRS 035°	Rwy Idg TDZE Apt Elev 8851 18 19	ILS RWY 4R (CAT II & III) GENERAL EDWARD LAWRENCE LOGAN INTL (BOS)			
When control tower reports tall vessels in approach use procedure NA. CAT II: RVR 1000 authorized with specific OPSPEC, MPSEC, or LOA approval and use of autoland or HUD to touchdown.		ALSIF-2	MISSED APPROACH: Climb to 3000 on BOS VOR/DME R-030 to WAXEN INT/ BOS 1.4 DME and hold.			
D-ATIS 135.0	BOSTON APP CON 120.6 263.1	BOSTON TOWER 128.8 257.8	GND CON 121.9	28	7.8	CPDLC



Gasper Fan

Note:

The PACKs regulate cabin temperature through the mixing of hot bleed air with bleed air that has been cooled. The cooling is done by two heat exchangers and a device called an Air Cycle Machine (ACM). Hot and cold bleed air is mixed by an air mix valve. Immediately downstream of the turbine wheel in the ACM is a water separator. This removes the condensed moisture that is a by-product of the ACM's cooling of the air. The cooling capacity of heat exchangers depends on the amount of ambient air flowing through them. This can be controlled through the positioning of cooling doors on the aircraft's belly that allows ram air to pass through the heat exchangers. The Gasper Fan is an adjustable air outlet situated above each passenger seat, which is part of the air conditioning and cabin air recirculation system.

DOORS

34. Close the doors by pressing LSHIFT+F1.



TRANSPONDER, TCAS, WEATHER RADAR & BUILT-IN TESTS

- 35. Set up the Transponder
 - a) Set Transponder frequency to 1200 (or as specified by ATC)
 - b) Set Transponder Mode to ON/ALT
- 36. Power up the Weather Radar by setting the SYS button to ON. A short built-in test will begin.
- 37. Set desired weather radar range (20 nm in our case).
- 38. Press the TCAS (Traffic & Collision Avoidance System) button to power up TCAS system.
- 39. Set Window Heat Switches – ON
- 40. Set Pitot Probe Heater Switches – ON

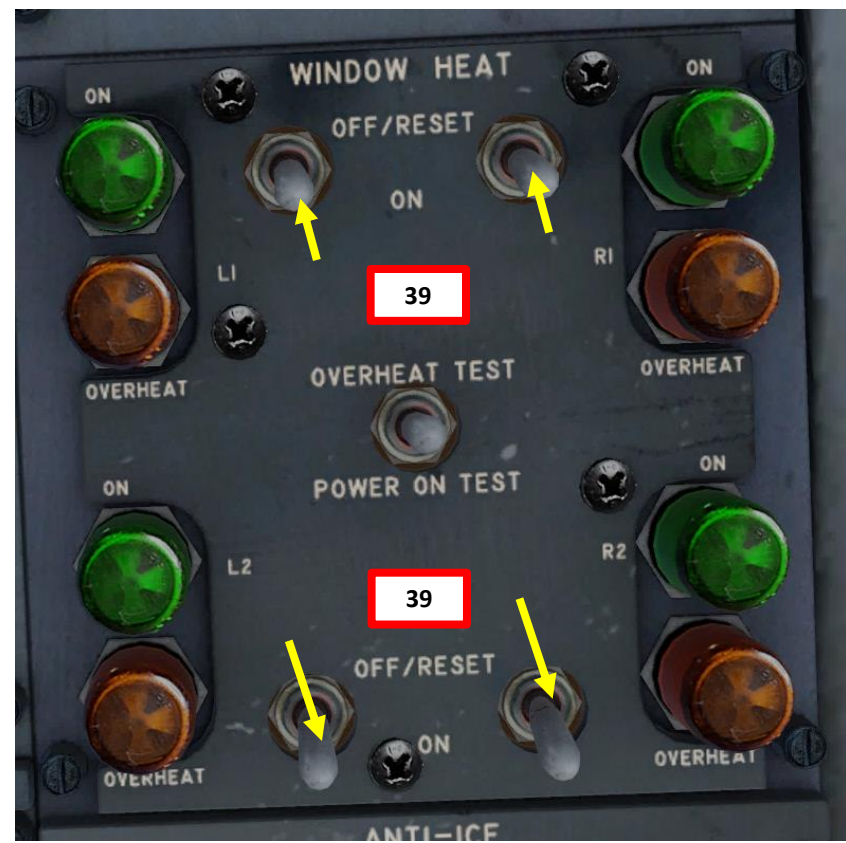
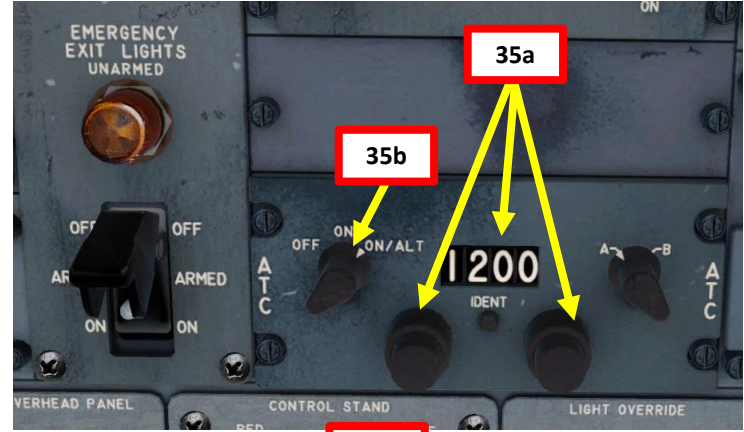
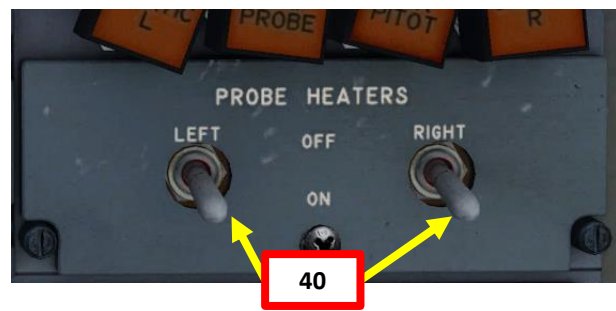

FLIGHT ENGINEER PANEL EXPLAINED

The Flight Engineer Panel is usually pretty confusing for those who are not used to it. As a matter of fact, the FE panel illustrates pretty well how the electrical, fuel and air systems are integrated together in the aircraft. Here is a brief explanation of what they represent.

AIR



LEFT A/C PACK
CONTROL CABIN & PASSENGER CABIN

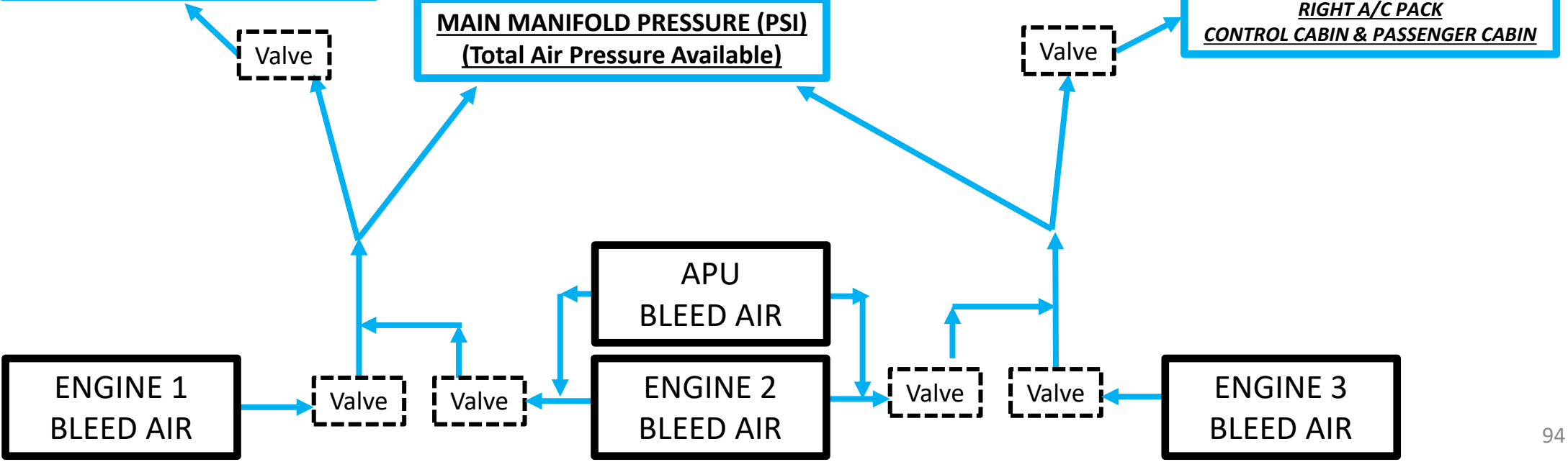

FLIGHT ENGINEER PANEL EXPLAINED

FUEL

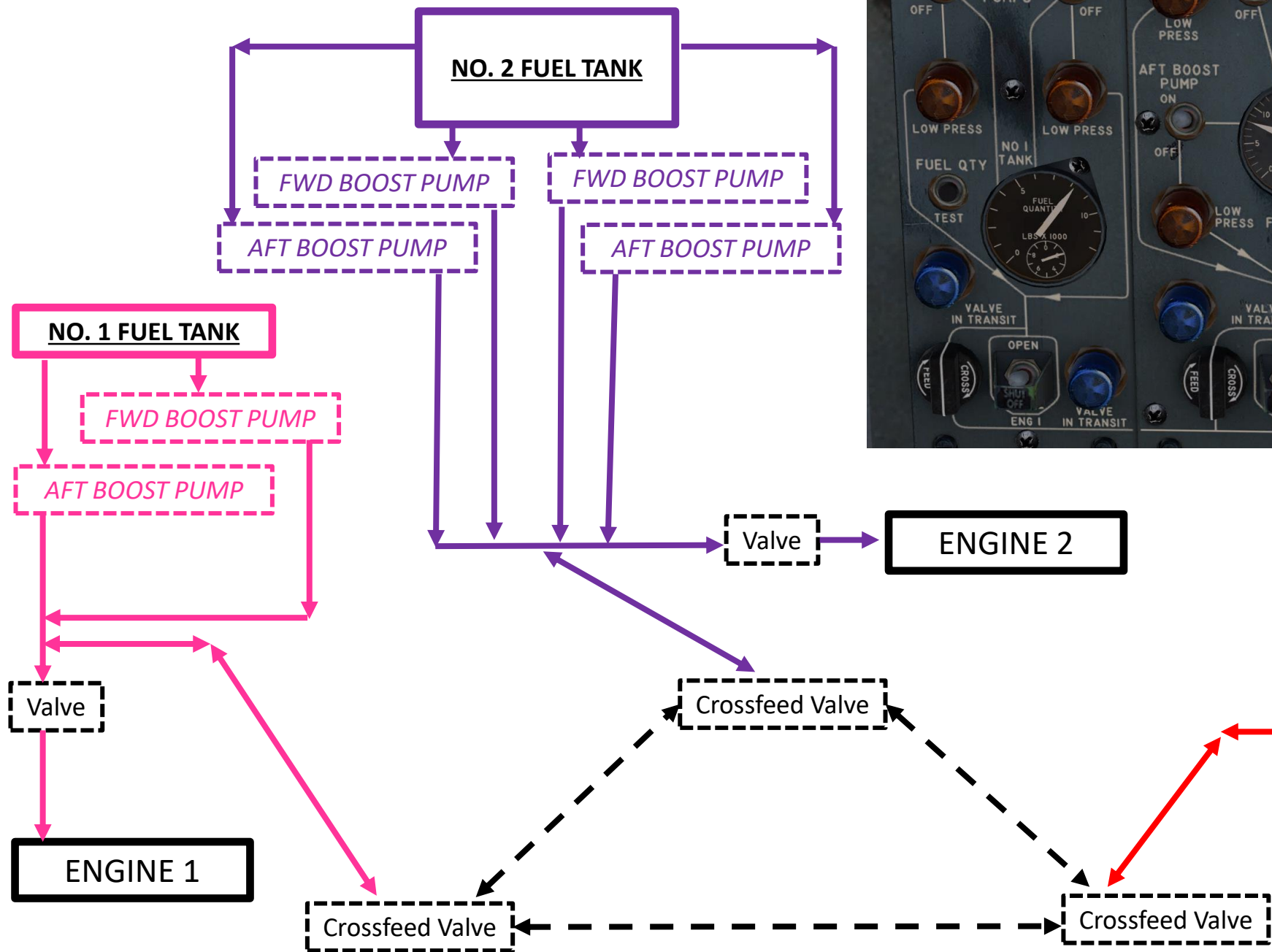

ENGINE START-UP

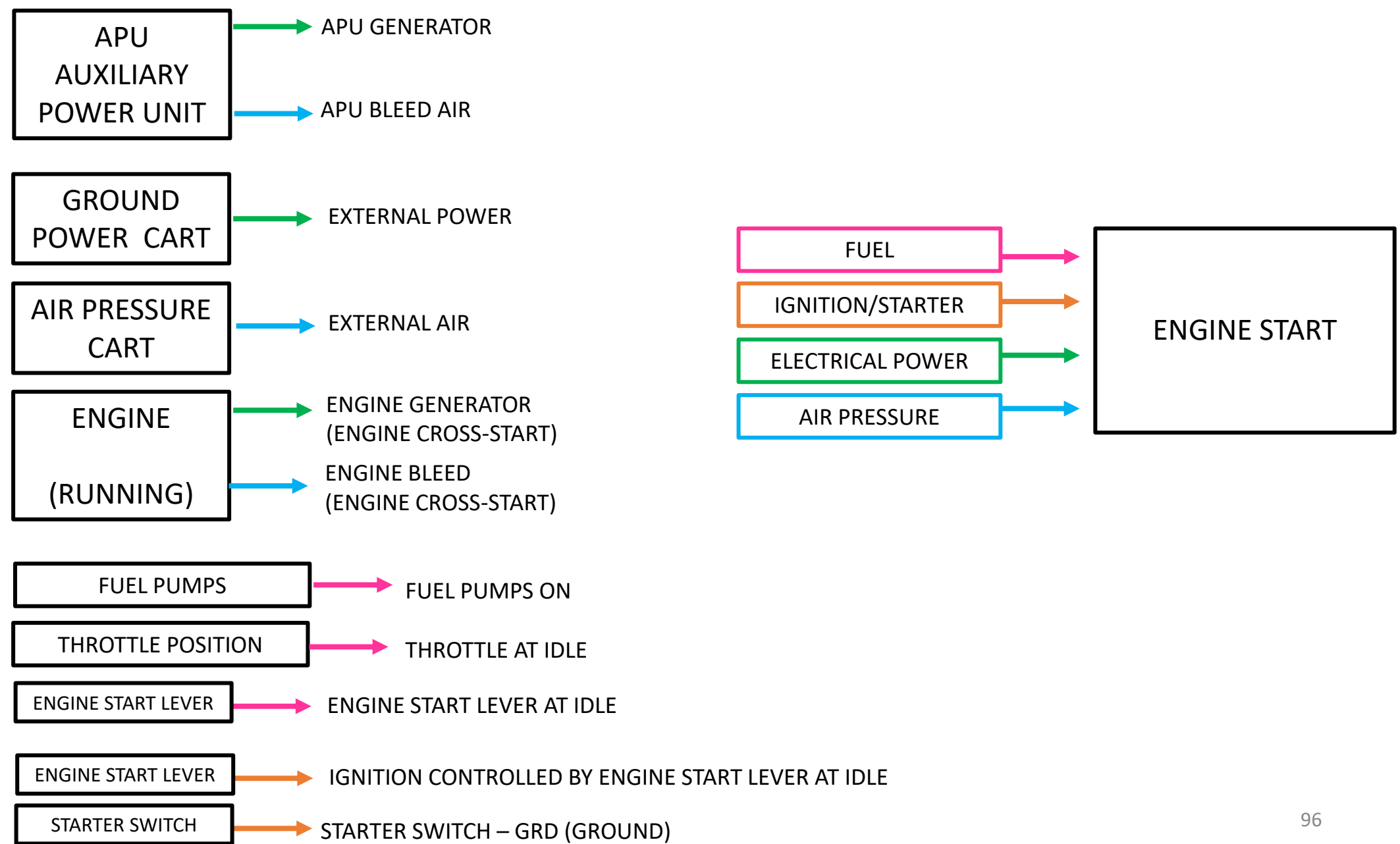



ENGINE START-UP

NOTE: It is usually common practice to start your engines during pushback. We will start our engines before that for simplicity.

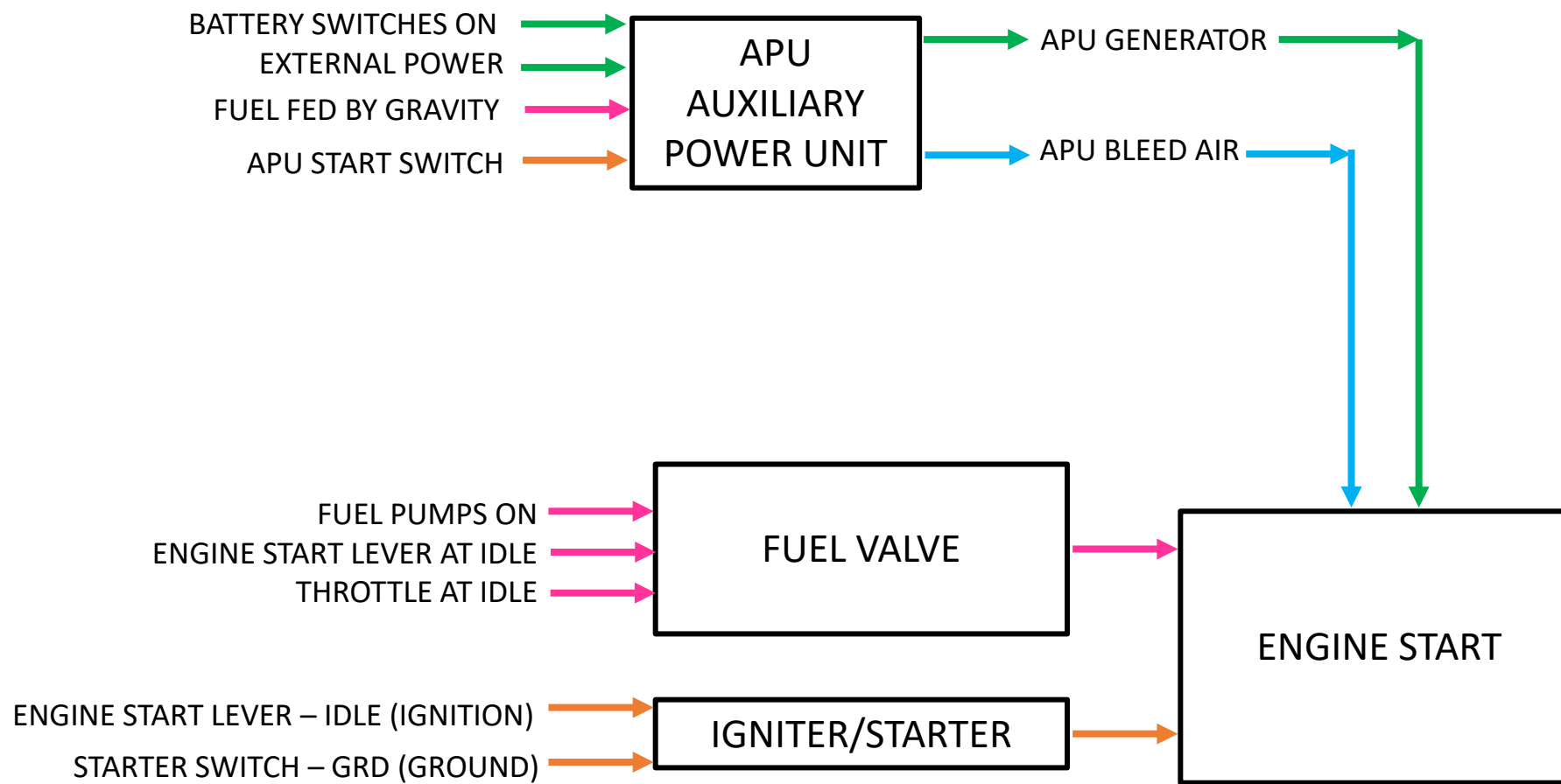



APU (AUXILIARY POWER UNIT) START

On the Aft APU Panel:

1. Set APU Generator switch momentarily to TRIP (DOWN) to open electrical circuit, then release switch to center position.
2. Set APU Generator Field Relay switch momentarily to TRIP (DOWN) to open electrical circuit, then release switch to center position.
3. Set APU Master Switch to START, wait for EXH (also known as EGT, Exhaust Gas Temperature) to rise, then set switch to ON. APU start sequence will begin automatically. You will not need fuel pumps yet since the fuel lines use gravity to feed the APU.
4. Monitor APU temperature (EXH) during start sequence to make sure no overheating occurs. The temperature will first rise in the 500-600 deg C range, then stabilize in the 300-340 deg C range.
5. Set APU Generator switch momentarily to CLOSE (UP) to close electrical circuit, then release switch to center position. The CIRCUIT OPEN light will extinguish.
6. Set APU Generator Field Relay switch momentarily to CLOSE (UP) to close electrical circuit, then release switch to center position. The FIELD light will extinguish.



On the Upper Flight Engineer Panel:

7. The External Ground Power switch will automatically reset itself to OFF.
8. Disconnect ground power
 - a) Click on the Options Sub-Menu button
 - b) Click on the GPU Cart button
9. Set Galley Power switch 1/2 and 3/4 – ON (UP)

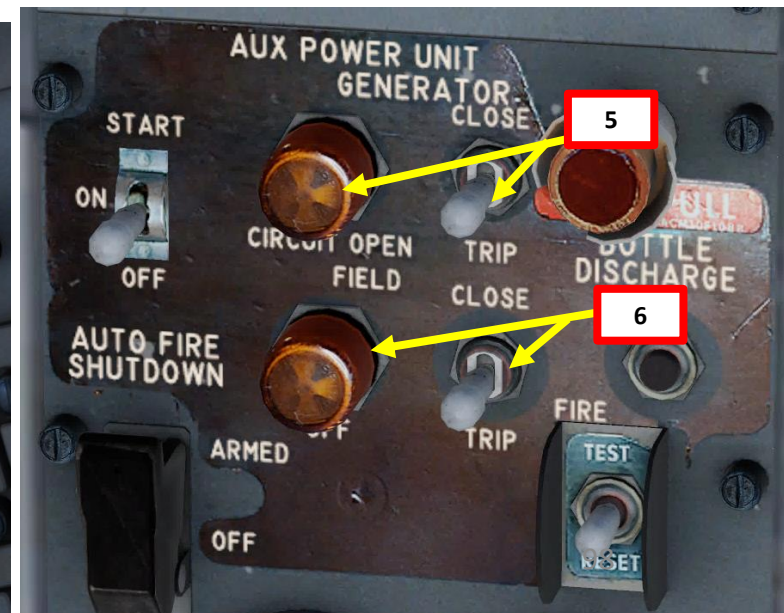
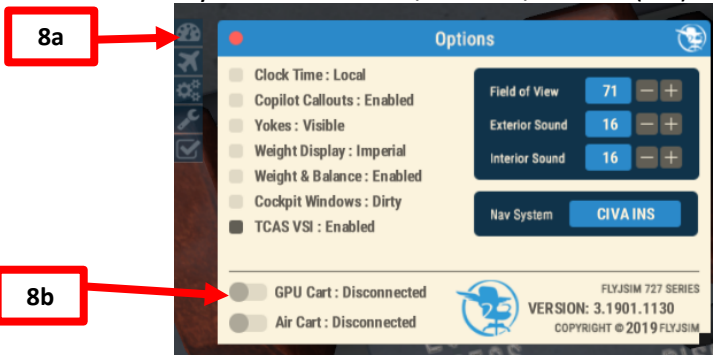

APU (AUXILIARY POWER UNIT) START

10. Set both left and right APU Pneumatic Cross-Feed Valve Switches - OPEN (UP). Set the ENGINE 1 BLEED AIR and ENGINE 3 BLEED AIR switches to OPEN (UP) as well.
11. Confirm that both Manifold Pressure needles stabilize above 30 PSI.
12. Make sure both COOLING DOORS are CLOSED.
13. Make sure the Left and Right A/C PACK (Pneumatic Air Conditioning Kit) switches are set to OFF. This is to make sure maximum APU bleed air pressure is available for engine start since the engine has a pneumatic starter.



ENGINE START-UP

- 14. Set all eight fuel pump switches to ON (UP).
The LOW PRESS lights should extinguish once the pumps are running.
- 15. Set all throttles to IDLE (fully aft)
- 16. Make sure all Engine Start Levers are at CUTOFF (DOWN).

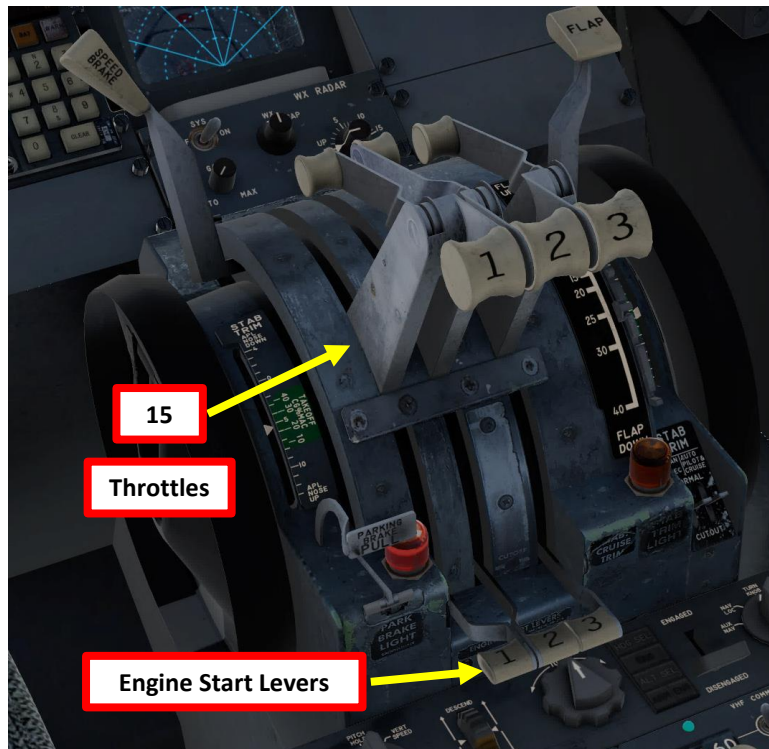

15

Throttles

Engine Start Levers

14



ENGINE START-UP

NOTE: We will start engine 2 first, then engine 3 and finally engine 1.

- 17. Set ENGINE 2 START switch to GROUND (Ground Start) to crank up the starter.
- 18. Make sure the START VALVE OPEN light for the No. 2 engine illuminates on the Flight Engineer Panel.
- 19. When No. 2 Engine N2 indication (High Pressure Compressor Rotation Speed) reaches 20 %, set No. 2 Engine Start Lever to IDLE (UP). This will energize the ignition system and lightoff the engine.
- 20. N1 indication (Fan Speed / Low Pressure Compressor Rotation Speed), Fuel Flow and EXH (Exhaust Gas Temperature) for No. 2 Engine should increase.
- 21. When No. 2 Engine parameters stabilize at about 20% N1 and 60 % N2, the ENGINE 2 START switch will automatically reset itself from GROUND to OFF.
- 22. No. 2 Engine is considered stabilized when the LOW OIL PRESSURE light is extinguished.



ENGINE START-UP

Starting Engine 3

- 23. Set ENGINE 3 START switch to GROUND (Ground Start) to crank up the starter.
- 24. Make sure the START VALVE OPEN light for the No. 3 engine illuminates on the Flight Engineer Panel.
- 25. When No. 3 Engine N2 indication (High Pressure Compressor Rotation Speed) reaches 20 %, set No. 3 Engine Start Lever to IDLE (UP). This will energize the ignition system and lightoff the engine.
- 26. N1 indication (Fan Speed / Low Pressure Compressor Rotation Speed), Fuel Flow and EXH (Exhaust Gas Temperature) for No. 3 Engine should increase.
- 27. When No. 3 Engine parameters stabilize at about 20% N1 and 60 % N2, the ENGINE 3 START switch will automatically reset itself from GROUND to OFF.
- 28. No. 3 Engine is considered stabilized when the LOW OIL PRESSURE light is extinguished.

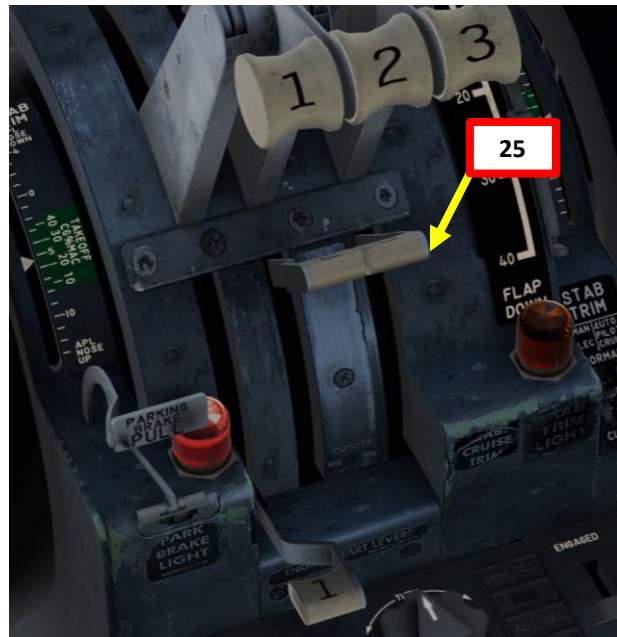

ENGINE START-UP

Starting Engine 1

- 29. Set ENGINE 1 START switch to GROUND (Ground Start) to crank up the starter.
- 30. Make sure the START VALVE OPEN light for the No. 1 engine illuminates on the Flight Engineer Panel.
- 31. When No. 1 Engine N2 indication (High Pressure Compressor Rotation Speed) reaches 20 %, set No. 1 Engine Start Lever to IDLE (UP). This will energize the ignition system and lightoff the engine.
- 32. N1 indication (Fan Speed / Low Pressure Compressor Rotation Speed), Fuel Flow and EXH (Exhaust Gas Temperature) for No. 1 Engine should increase.
- 33. When No. 1 Engine parameters stabilize at about 20% N1 and 60 % N2, the ENGINE 1 START switch will automatically reset itself from GROUND to OFF.
- 34. No. 1 Engine is considered stabilized when the LOW OIL PRESSURE light is extinguished.

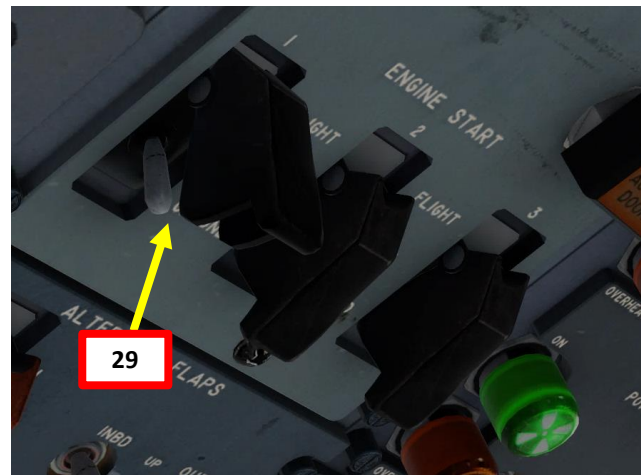
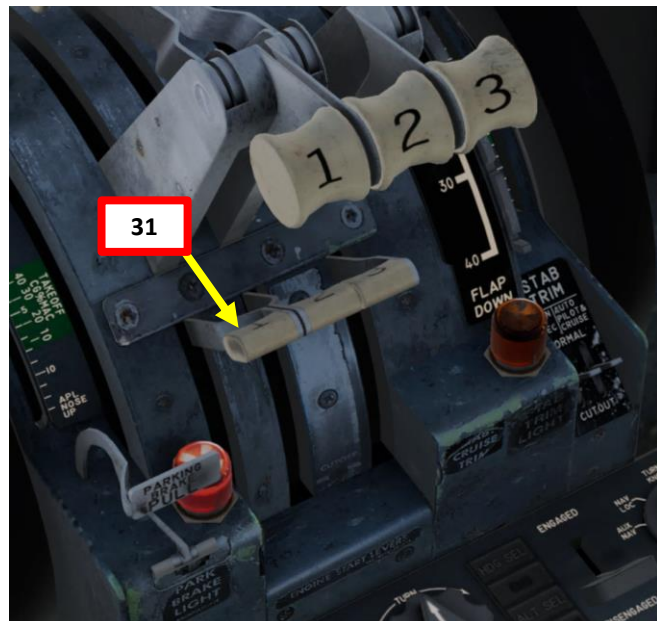

ENGINE START-UP

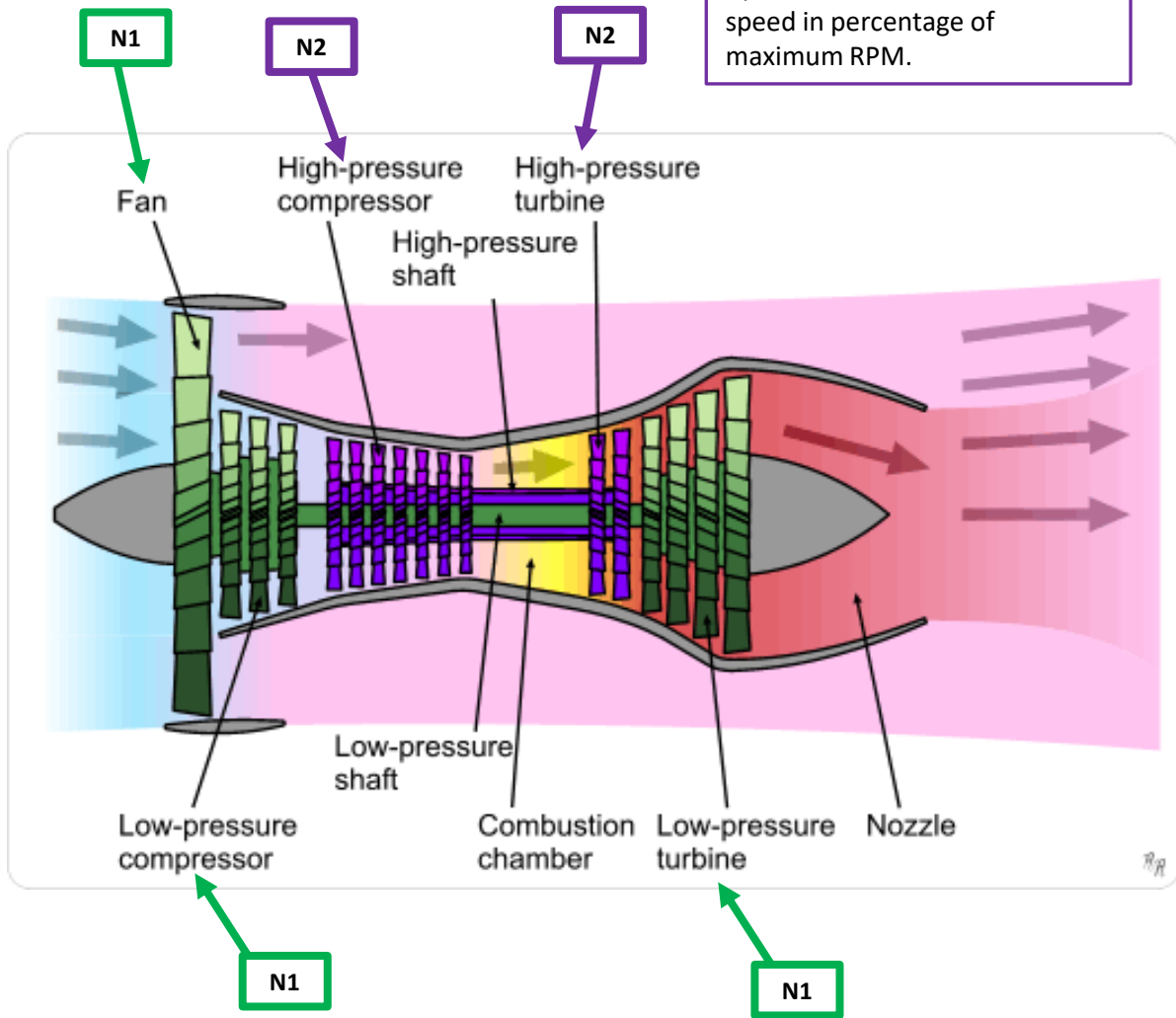

High-pressure compressor and high-pressure turbine are driven by the same shaft. This is N2 speed in percentage of maximum RPM.

Fan, low-pressure compressor and low-pressure turbine are driven by the same shaft. This is N1 speed in percentage of maximum RPM.

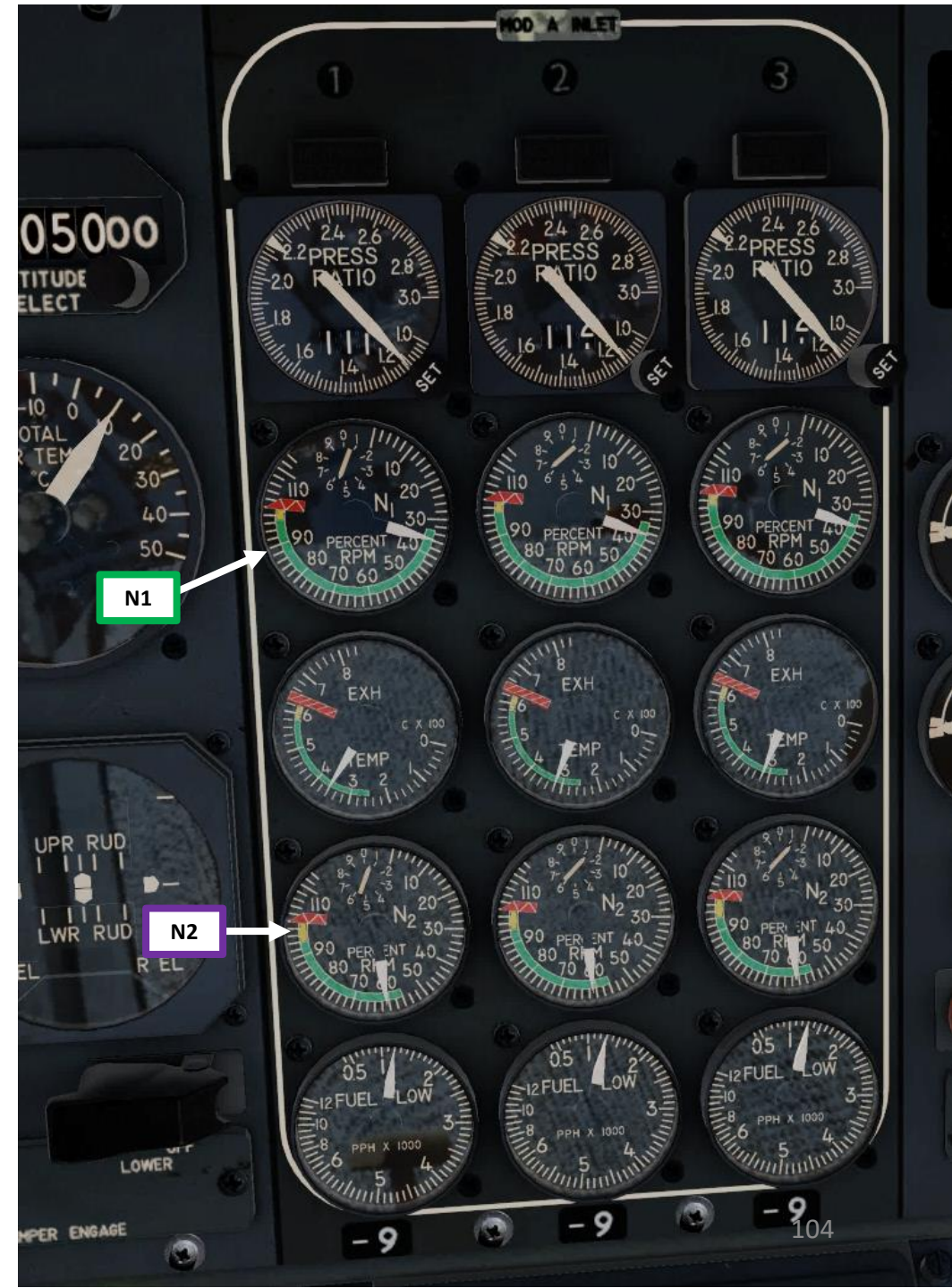

COMPLETE PRE-FLIGHT

35. Set ENG 1 & 2 HYDRAULIC PUMP switches – ON. Verify that you have positive hydraulic pressure in System A.
36. Set ELEC 1 & 2 HYDRAULIC PUMP switches – ON. Verify that you have positive hydraulic pressure in System B.
37. Set BUS TIE 1, 2 and 3 switches momentarily to CLOSE (UP) to close electrical circuit, then release switches to center position.
38. Set GENERATOR 1, 2 and 3 switches momentarily to CLOSE (UP) to close electrical circuit, then release switches to center position.
39. Set FIELD 1, 2 and 3 switches momentarily to CLOSE (UP) to close electrical circuit, then release switches to center position.
40. Set the APU Generator and Field switches to TRIP, then set APU Master switch – OFF (DOWN)
41. Set the Left and Right A/C PACK (Pneumatic Air Conditioning Kit) switches to ON.
42. Set CARGO HEAT OUTFLOW switch - NORMAL
43. Set the Gasper Fan switch – ON
44. Set Cabin Pressure switch – FLIGHT

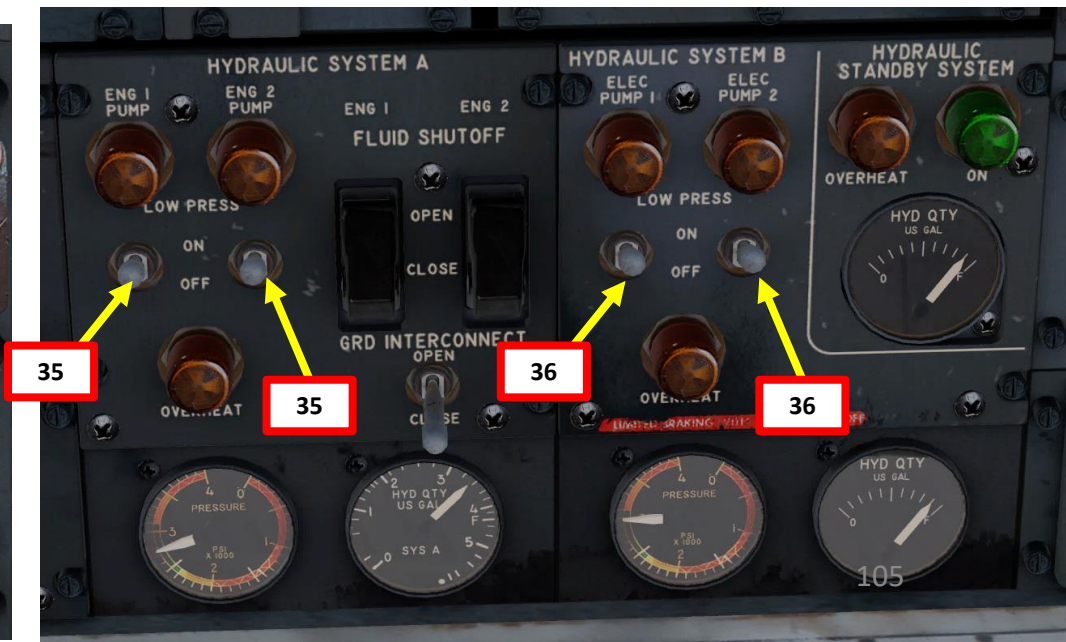

COMPLETE PRE-FLIGHT

45. Set the Emergency Exits Lights to ARMED (Middle Position), then close the black cover guard.
46. Landing Lights switches – ON
47. Taxi Light switch – ON
48. Runway Turnoff Lights switches – ON
49. Strobe Light switch – ON
50. Navigation Lights switch – ON
51. Beacon Light switch – ON
52. Wing Light switch – ON
53. Logo Light switch – ON
54. Set NO SMOKING switch – ON
55. Set FASTEN SEAT BELTS switch – ON
56. Set PROBE HEATERS switches – ON
57. On the overhead panel, hold the STALL WARNING switch to TEST and make sure that you hear the stall warning sound (annoying rattle). Reset switch back to NORMAL.
58. Press the GROUND PROXIMITY SYS TEST to start a series of automated tests. You should hear a series of aural warnings like « Glide Slope » or « Pull up! » « Windshear! » « Terrain! » « Airspeed Low! » « Sink Rate! » « Don't sink! » « Too low, Terrain! » « Too low, flaps! », etc.

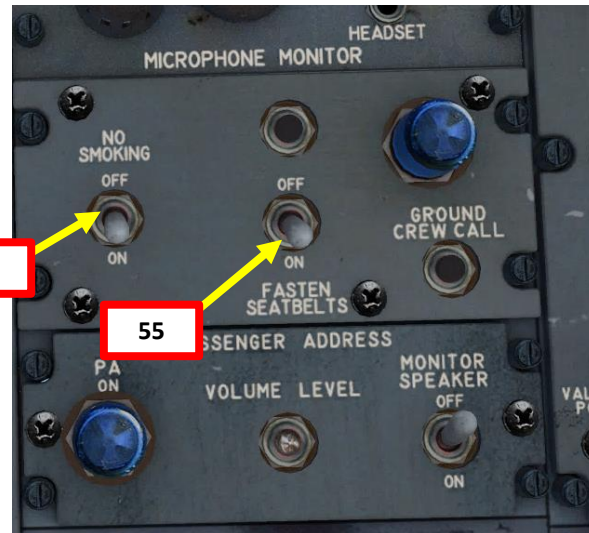
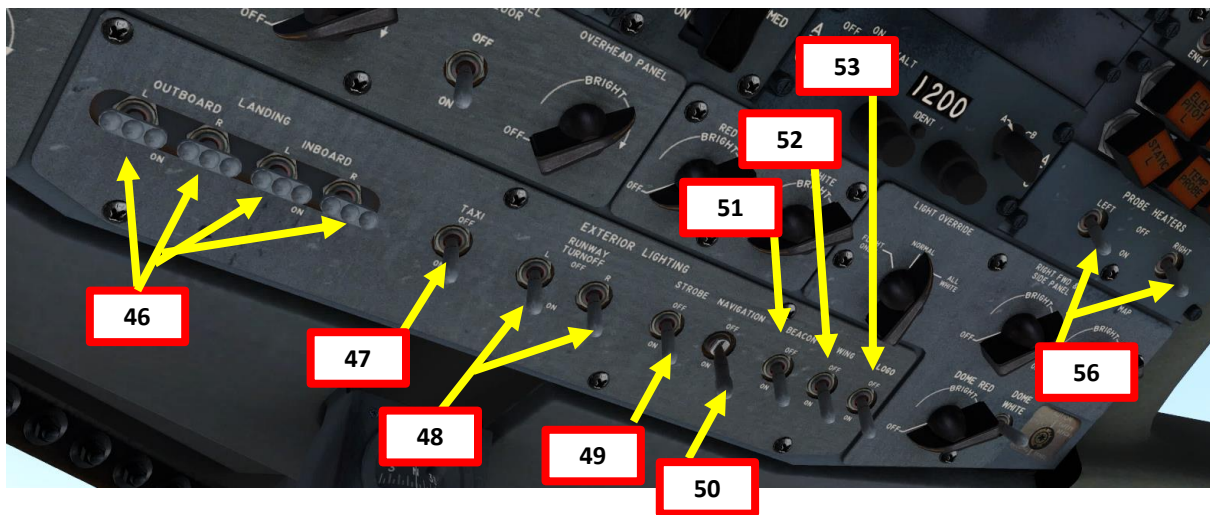

COMPLETE PRE-FLIGHT

- 59. As per the V-speed card, we intend to takeoff with flaps at 20 degrees. Set flaps lever to 20 degrees
- 60. Verify that outboard and inboard flaps are at 20 deg
- 61. Verify that both Yaw Damper switches are engaged

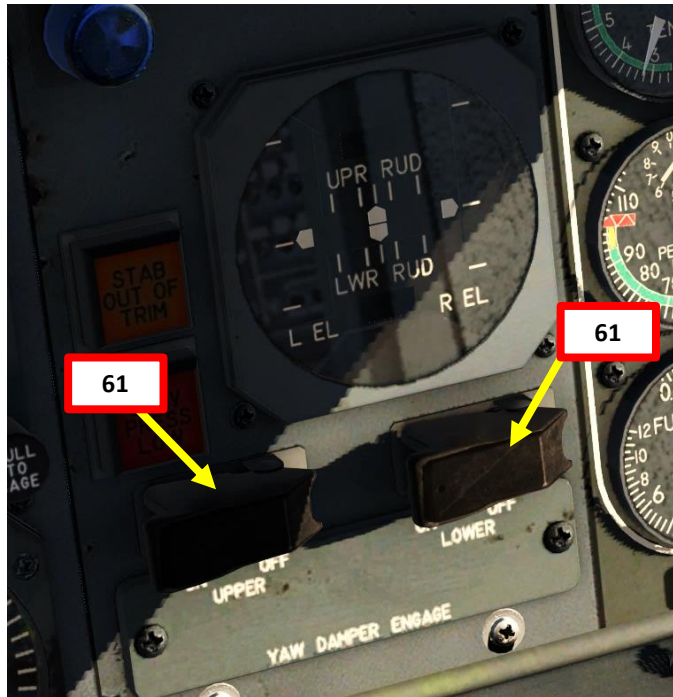
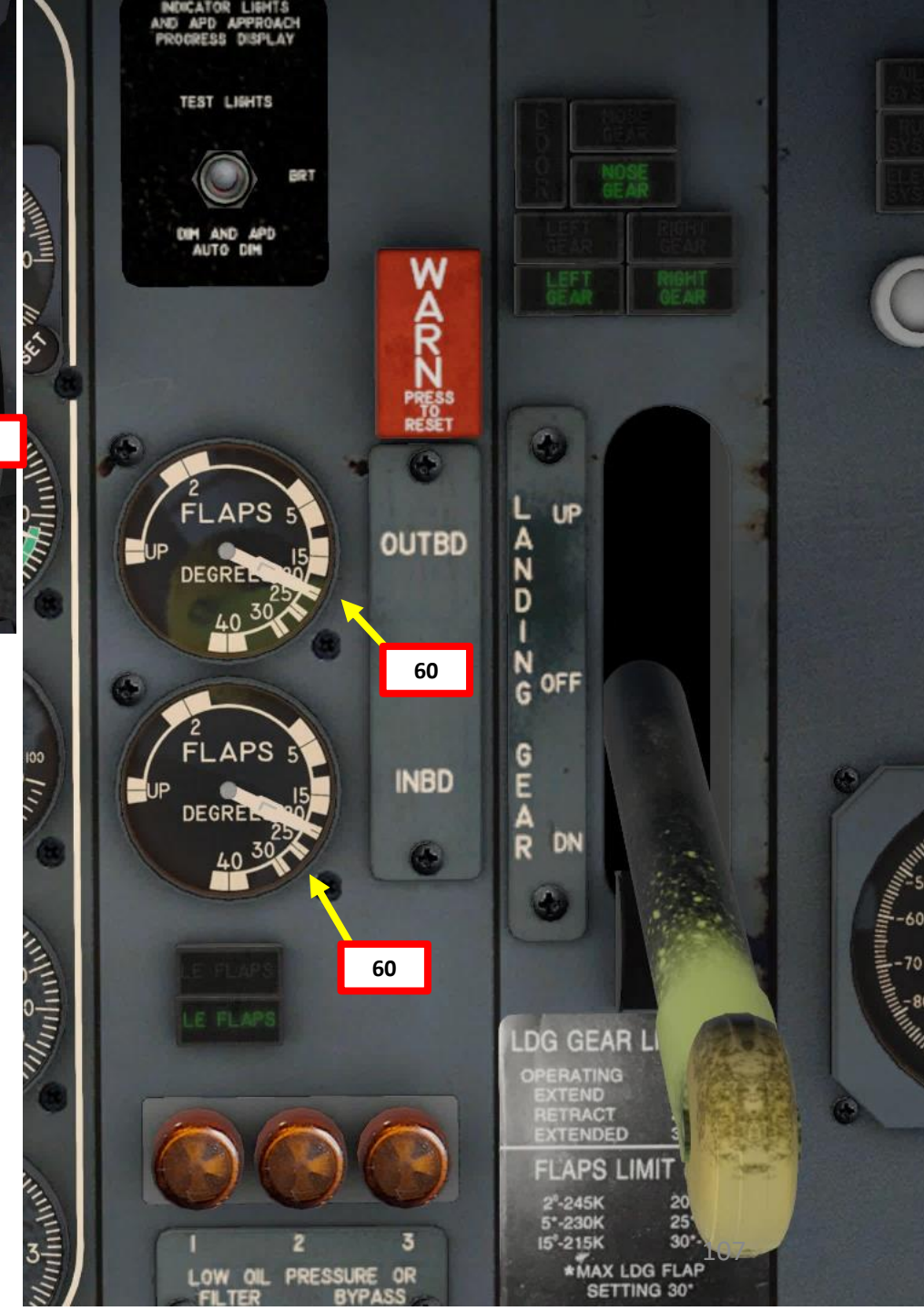
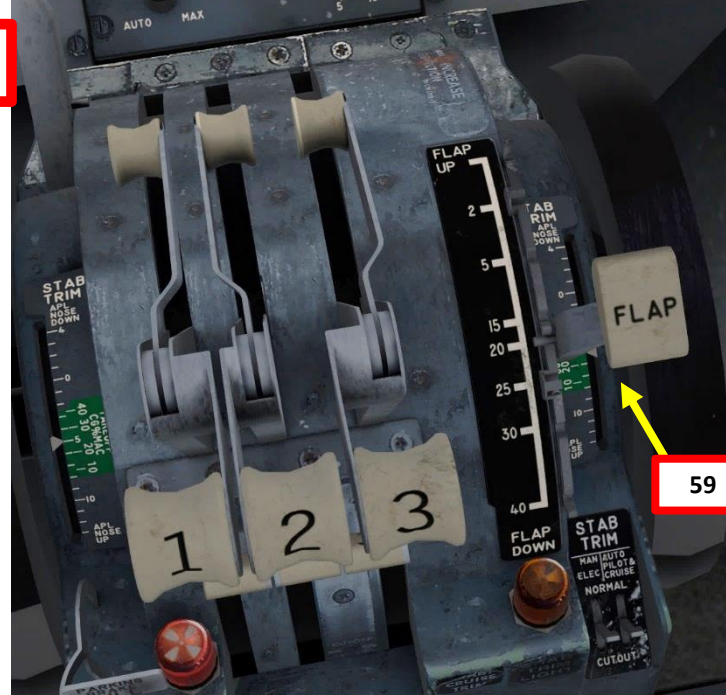

TAKEOFF		LANDING	
727			
NORMAL EPR	REDUCED EPR	GO-AROUND EPR	
2.15			
97.4			
NORMAL N ₁	REDUCED N ₁	GO-AROUND N ₁	
FLAPS	V ₁	INITIAL CLIMB EPR	
20	113	FLAP RETRACT/MAN. SPEEDS	
5.15	V _R	20/15	135
STAB TRIM	113	5	155
	V ₂	2	190
	125	0	200
CLAMP TIME			
109039	FUEL 24961	T.O. GWT 133999	
TEMP 10	CRUISE 30.16	PA CG	
FLT/TRIP NO.		DATE	

PUSHBACK

- The FlyJSim 727-100 requires the free external plugin BetterPushback to be installed in order to use pushback functionalities. You can find it here: <https://github.com/skiselkov/BetterPushbackC/releases/download/v0.46/BetterPushback.zip>
- The BetterPushback files need to be installed in the following folder:
C:\Program Files\X-Plane\X-Plane 11\Resources\plugins\BetterPushback

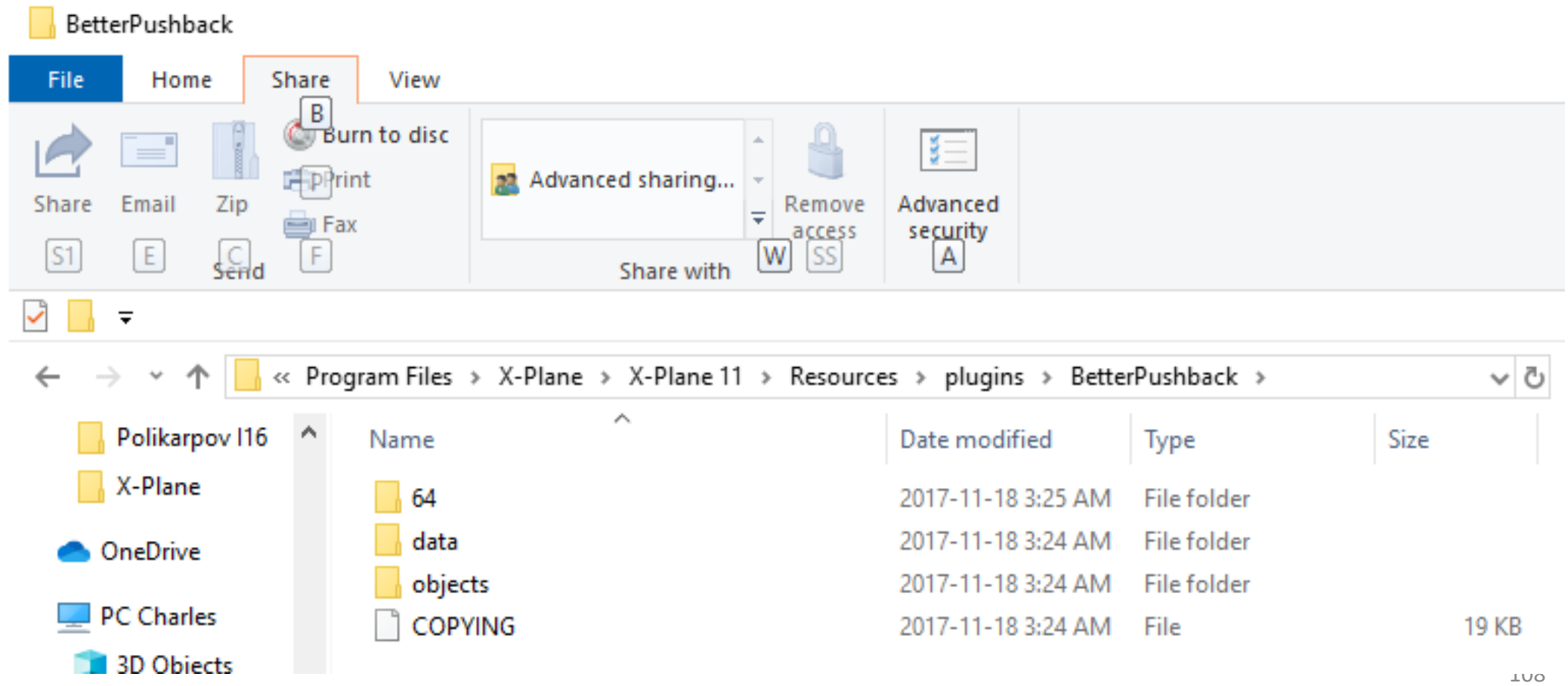

PUSHBACK

1. First, you need to pre-plan the pushback trajectory. In your Plugins menu, select "Better Pushback" sub-menu, then click "Pre-plan pushback".
2. You will automatically see a top-down view of your aircraft. You can drag your mouse to your desired aircraft position and rotate the aircraft by scrolling the middle mousewheel button.
3. Once the yellow aircraft silhouette is to your liking, left click (silhouette will turn green) and press "ENTER" to save the pushback trajectory.



PUSHBACK

4. Verify that Anti-Skid switch is ON
5. Before beginning pushback, make sure your landing lights and taxi lights are off to avoid blinding the ground crew.
6. Engage Parking Brake (PULLED). Verify that BRAKE LIGHT is illuminated.
7. Press and hold the GROUND CREW CALL button for about 4 to 5 seconds to contact ground crew personnel
8. The ground crew will connect the Pushback Tug and ask you to release the parking brake when ready
9. Disengage Parking Brake (FWD). Verify that BRAKE LIGHT is extinguished
10. The pushback tug will start moving the aircraft
11. When the pushback procedure is finished, the ground crew will ask you to set the parking brake to disconnect the tug
12. Engage Parking Brake (PULLED). Verify that BRAKE LIGHT is illuminated.

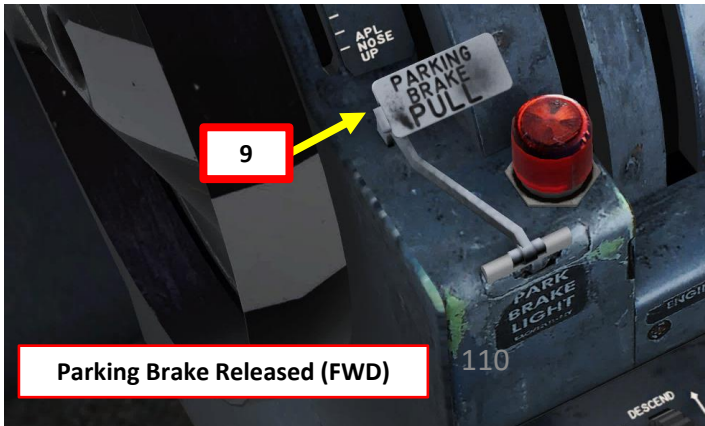
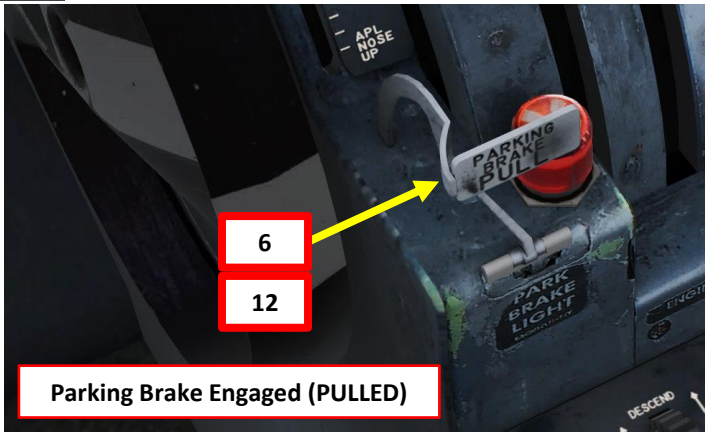

PUSHBACK

13. Give the ground crew the thumbs up to disconnect the tug



727-100

PART 5 - TAXI

PUSHBACK



TAXI

The 727 is steered on the ground by using a tiller. X-Plane allows you to map an axis to the tiller.



Nose Wheel Steering Tiller
(used to steer aircraft on the ground)

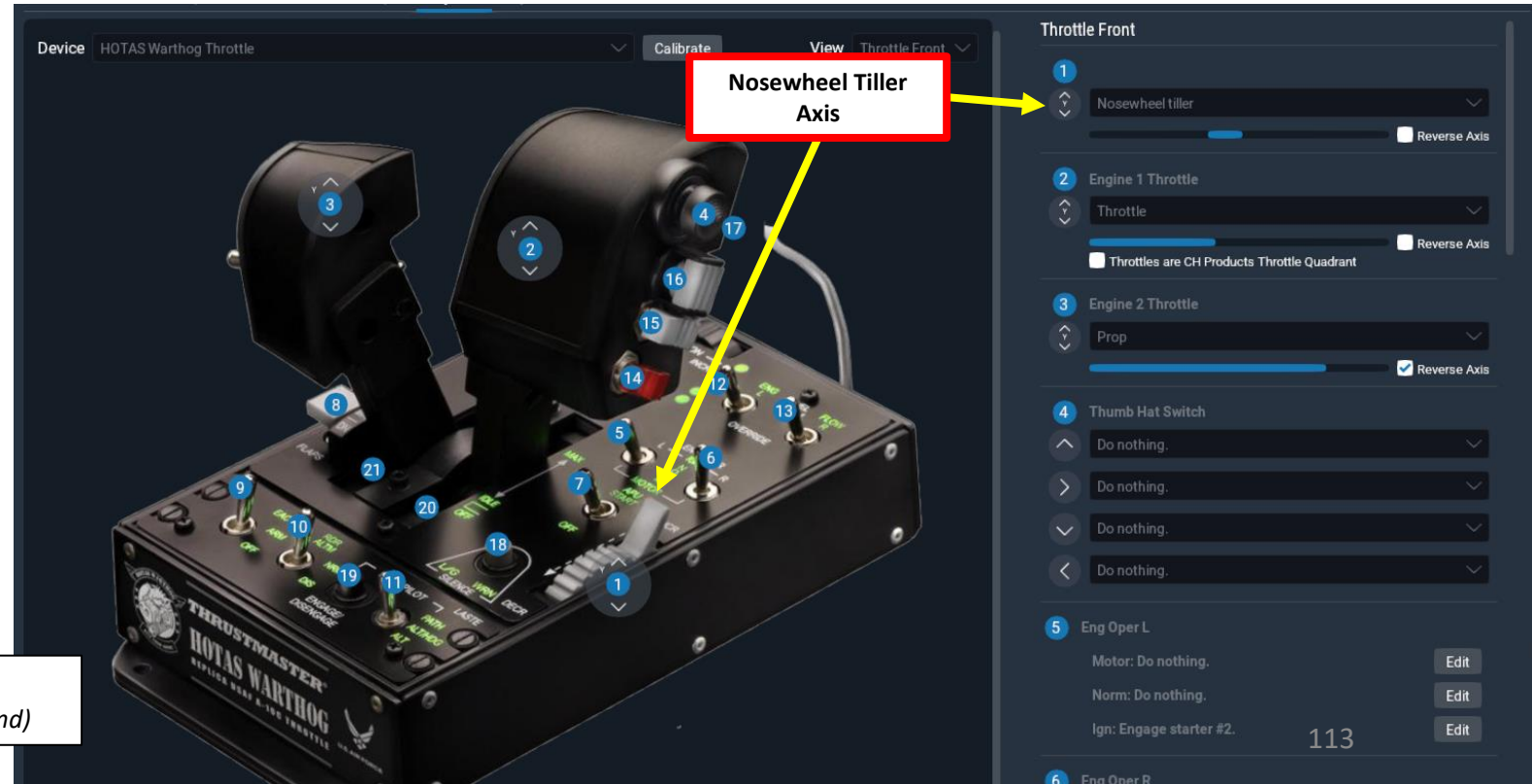

TAXI

Check signs to follow the taxi route towards the holding point (H6)

← N NS B N →

727-100

PART 5 - TAXI

FD
LI
TR

H6
OFF
GA
PITCH
COMMAND

APD
F/D A/P

INCREASE
PNEUMA

TAXI

727-100

PART 5 - TAXI



TAKEOFF

1. Line up on the runway
2. Set Auto-Brake Switch – RTO (Rejected Takeoff)
3. Verify that your flaps are set to 20 as per the V-speed card
4. Set your EPR (Engine Pressure Ratio) bugs to the NORMAL EPR written on the V-speed card
5. Release parking brake and hold wheel brakes

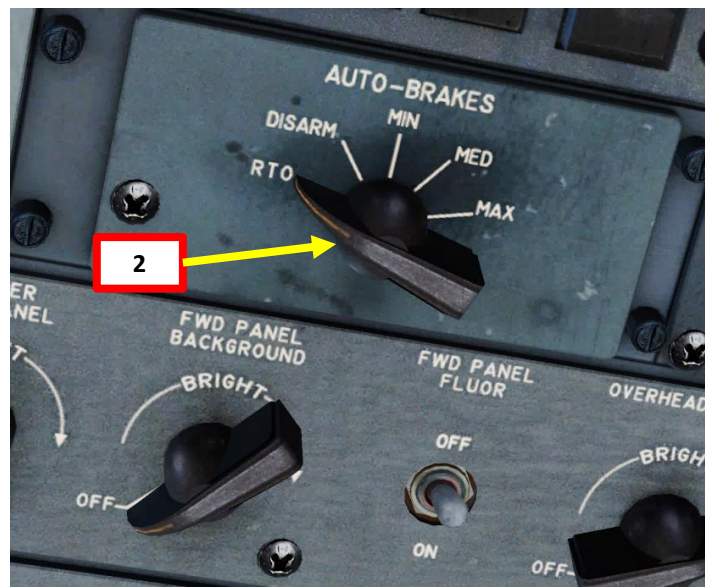
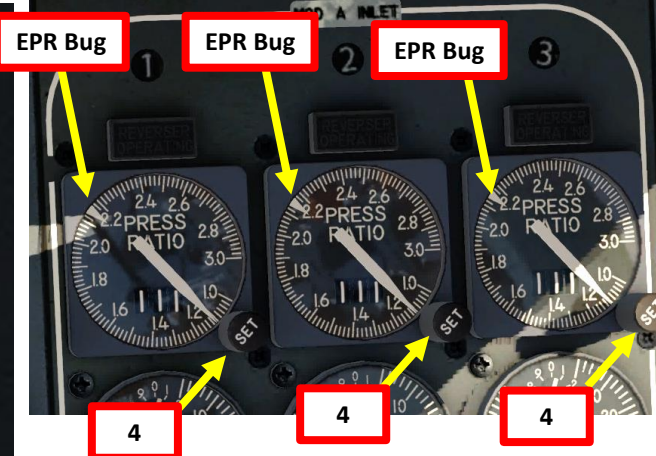
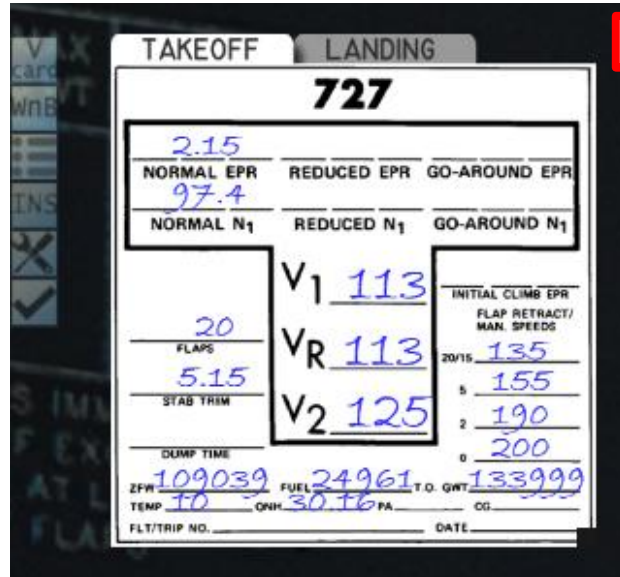

TAKEOFF

6. Set Autopilot PITCH SELECTOR to PITCH HOLD
7. Set Autopilot NAV SELECTOR to TURN KNOB
8. Hold brakes and throttle up to an EPR of maximum 2.15 EPR (Normal Engine Pressure Ratio as per V-speed card). You can also use a maximum N1 of 97.4 % as a reference.
9. Release brakes and accelerate

TAKEOFF			LANDING		
727					
2.15					
NORMAL EPR	REDUCED EPR	GO-AROUND EPR			
97.4					
NORMAL N ₁	REDUCED N ₁	GO-AROUND N ₁			
			V ₁ 113		
			V _R 113		
			V ₂ 125		
20			INITIAL CLIMB EPR		
FLAPS			FLAP RETRACT/ MAN. SPEEDS		
5.15			20/15 135		
STAB TRIM			1 155		
			2 190		
			3 200		
DUMP TIME					
ZFW 109039	FUEL 24961	T.O. GW 133999			
TEMP 70	QNH 30.16	PA			
FLT/TRIP NO.		DATE			





TAKEOFF

- 10. As you speed up to 80 kts, the First Officer will call out « 80 knots ». The airspeed indicator comes alive at that speed.
- 11. Once you reach V1 (Decision Speed, 113 kts), start a gentle rotation.
- 12. Once you confirm a « Positive Rate », retract landing gear by setting the Landing Gear Lever UP, waiting for the landing gear to retract, and then setting the gear lever to the OFF (Middle) position to lock it.

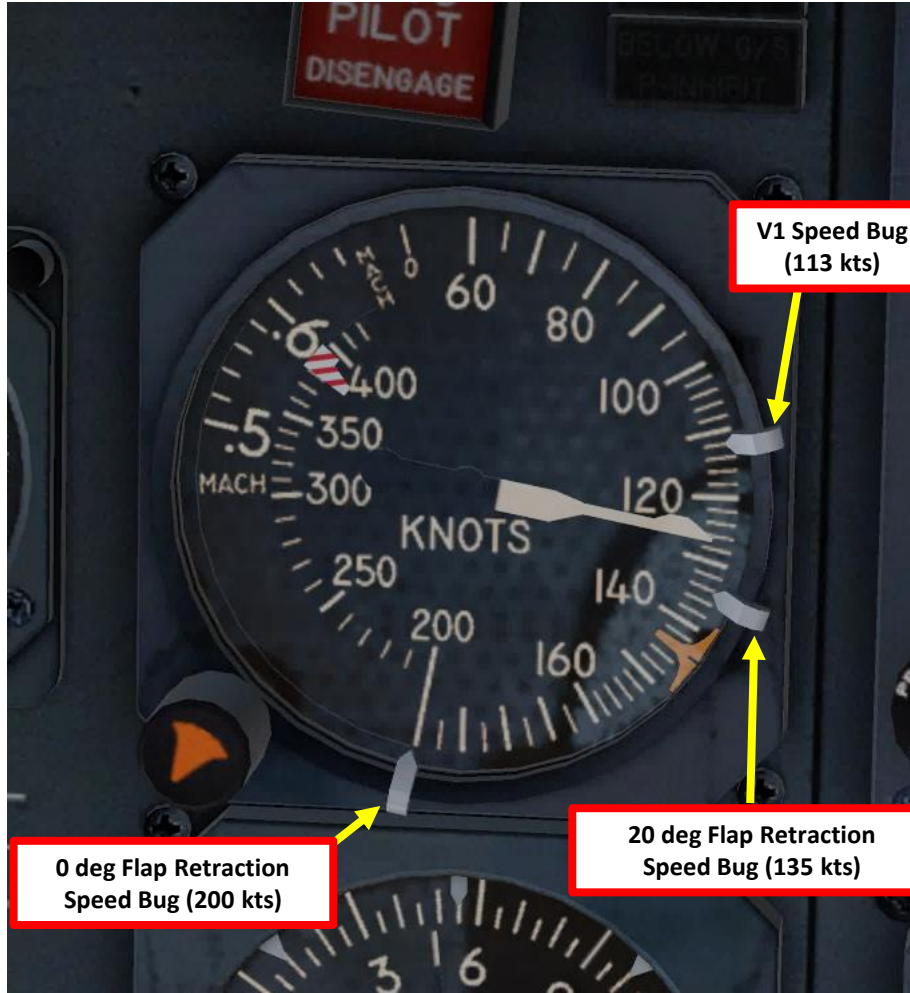

V1 Speed Bug (113 kts)

20 deg Flap Retraction Speed Bug (135 kts)

0 deg Flap Retraction Speed Bug (200 kts)

TAKEOFF		LANDING	
727			
2.15			
NORMAL EPR	REDUCED EPR	GO-AROUND EPR	
97.4			
NORMAL N ₁	REDUCED N ₁	GO-AROUND N ₁	
	V ₁ 113	INITIAL CLIMB EPR	
20	V _R 113	FLAP RETRACT/MAN. SPEEDS	
5.15	V ₂ 125	20/15 135	
STAB TRIM		5 155	
		2 190	
		0 200	
DUMP TIME			
ZFW 109039	FUEL 24961	T.O. GWT 133999	
TEMP 70	QNH 30.16	PA	CG
FLT/TRIP NO.		DATE	

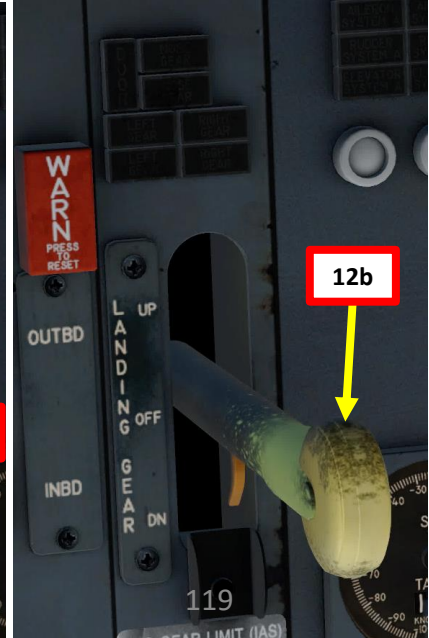
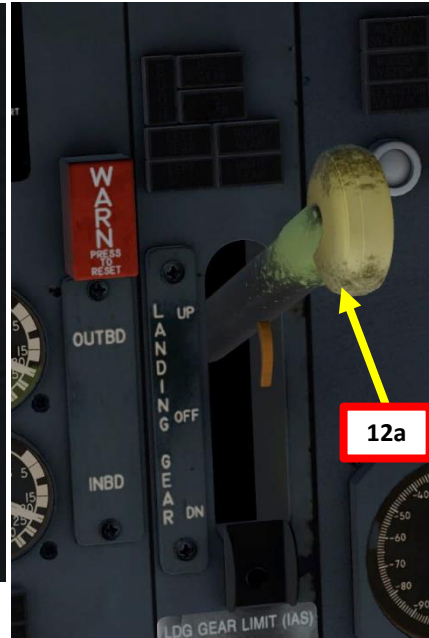



TAKEOFF

13. Verify that the GPS/NAV Selector Switch is set to NAV.
14. Engage autopilot
15. Set Heading Bug to 047 deg for the first turn and verify that selected altitude is 5000 ft
16. Arm ALTITUDE SELECT autopilot mode
17. When climbing above 1000 ft, engage HEADING SELECT autopilot mode. Make sure the MODE SELECTOR on the glareshield is set to OFF.
18. Aircraft will now steer to 047 as set by the Heading Select bug.
19. Set the Flight Director PITCH COMMAND knob as shown to allow a smooth climb
20. Rise flaps as per flaps schedule.
 - a) Set flaps to 15 at 150 kts
 - b) Set flaps to 5 at 160 kts
 - c) Set flaps to 2 at 190 kts
 - d) Set flaps to 0 at 200 kts

19

AFTER TAKEOFF NORMAL MANEUVERING SPEEDS

FLAPS (DEG)	BELOW MAX LANDING WEIGHT	ABOVE MAX LANDING WEIGHT
0	200	210
2	190	200
5	160	170
15	150	160
25	140	150

NOTE: FOR MANEUVERS IMMEDIATELY AFTER TAKE-OFF EXCEEDING 15 DEG BANK, MAINTAIN AT LEAST $V_2 + 10$ KTS AT TAKE-OFF FLAPS

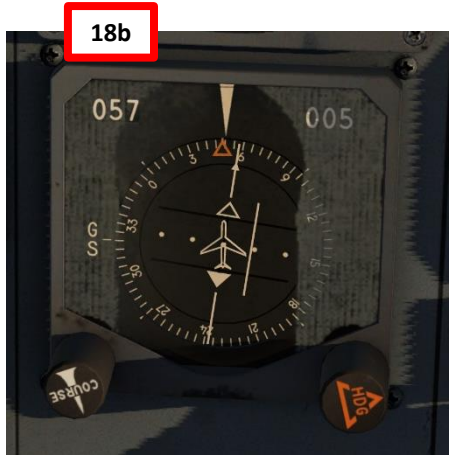
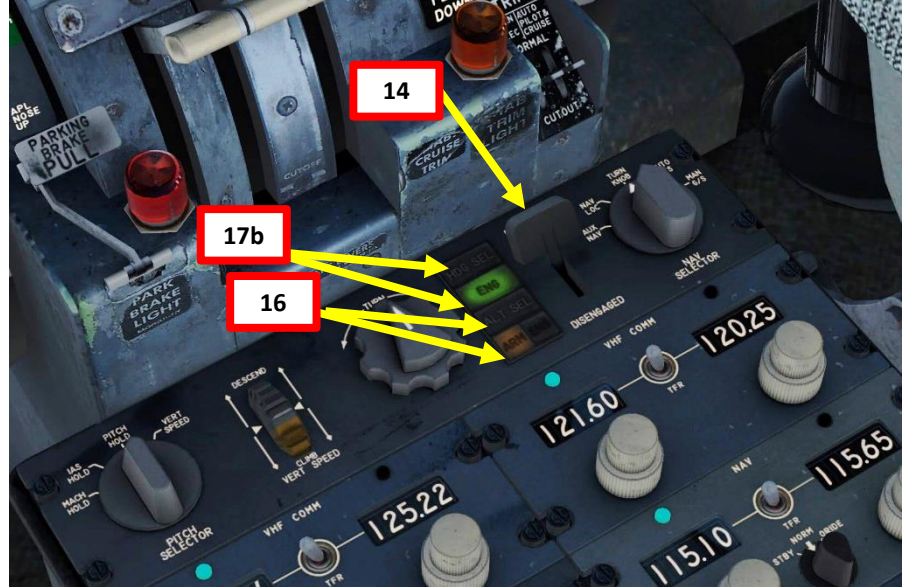

Aircraft will steer to line up orange heading bug with current heading

TAKEOFF



CLIMB

1. Set Selected Airspeed Bug to 250 kts
2. Set Autopilot PITCH SELECTOR to IAS HOLD (Airspeed Hold). The aircraft will now climb while maintaining this speed.
3. When reaching 5,000 ft (the end of the first climb segment):
 - a) Landing Lights switches – OFF
 - b) Taxi Light switch – OFF
 - c) Runway Turnoff Lights switches – OFF
 - d) The ALT light will turn green when target altitude has been reached.
 - e) Set Selected Altitude to cruising altitude of 33000 ft
 - f) Press the ALT SEL button to arm the Altitude Select autopilot mode.
4. Set Autobrake switch – DISARM
5. Throttle back to a cruise setting of 92 % N1.

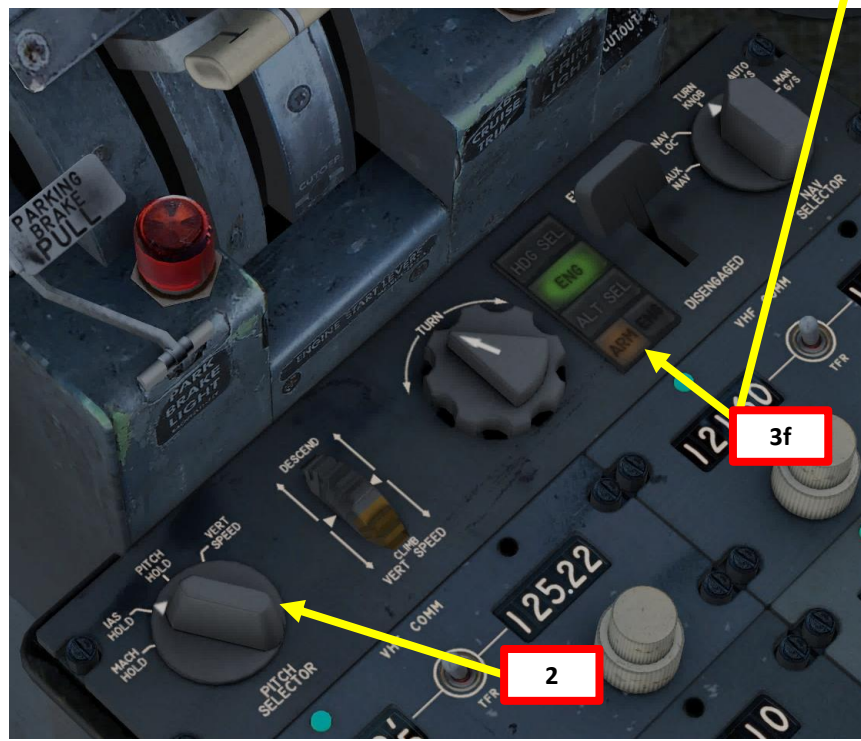
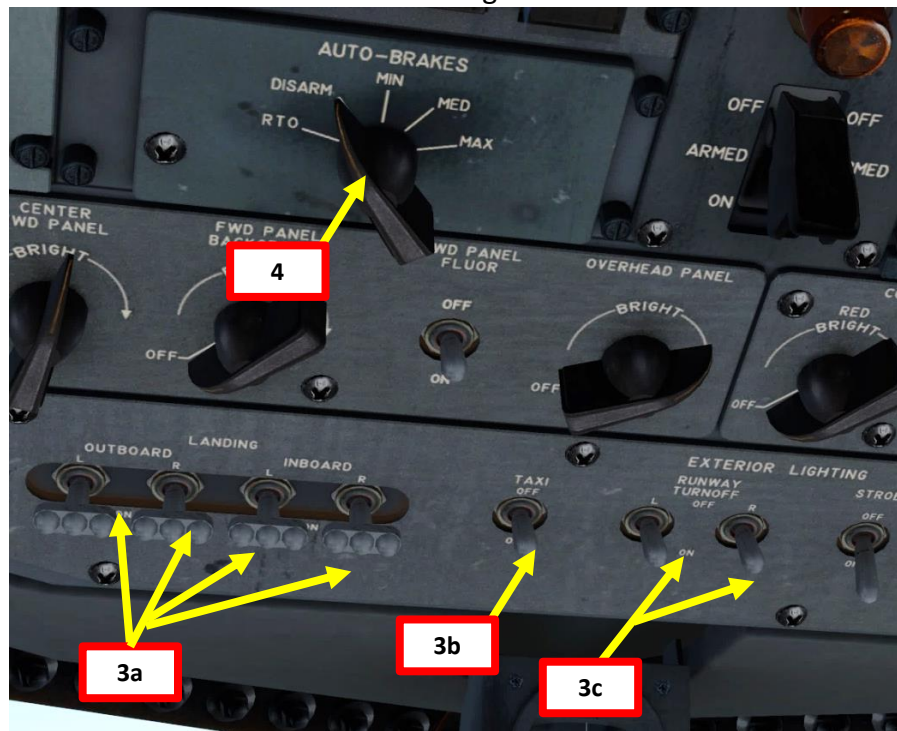
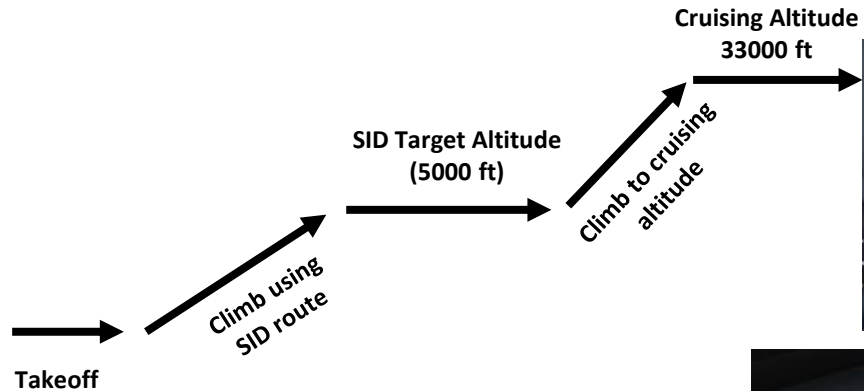

CLIMB

6. To track the waypoints we entered in our CIVA, we will choose what waypoint we want to track first. Press the WY PT CHG (Waypoint Change) button and press “01”.
7. The FROM-TO display will now show 01, meaning that we are flying FROM waypoint 0 (which is the position of the aircraft) TO waypoint 1 (SIKBO).
8. Set the GPS/NAV Selector Switch set to GPS and also set the NAV SELECTOR to AUX NAV. This will set the CIVA as the data source that drives the autopilot, as shown by the “GPS” light on the APD panel.
9. Set the Flight Director Mode Selector switch to OFF.
10. The aircraft will now steer from your current position (waypoint 0) towards waypoint 1 (SIKBO).
11. Set the CIVA Data Selector Switch to DIS/TIME to display the distance from tracked waypoint (in nautical miles) and the time to waypoint (in minutes). The picture shows that we are 13 nm from waypoint 1 and that we will cross it in 2.9 minutes.

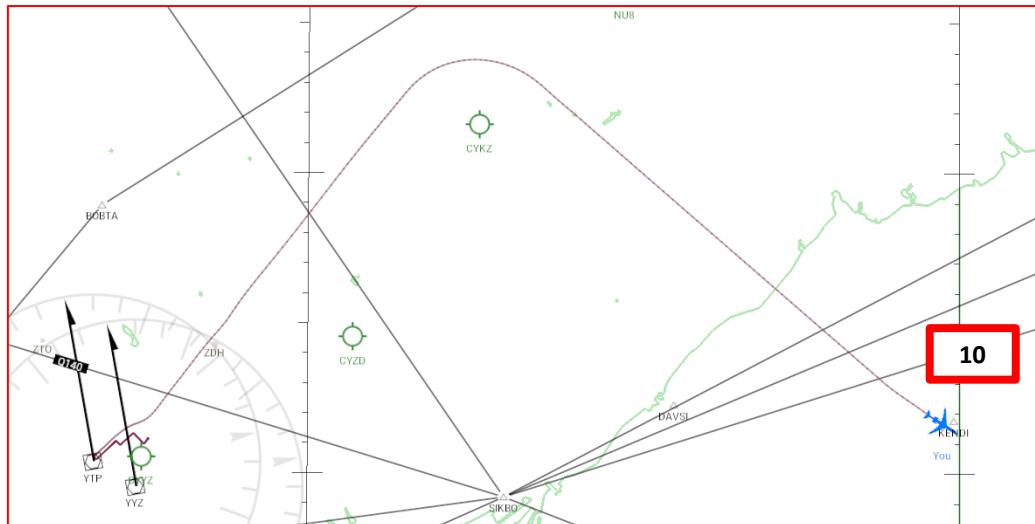
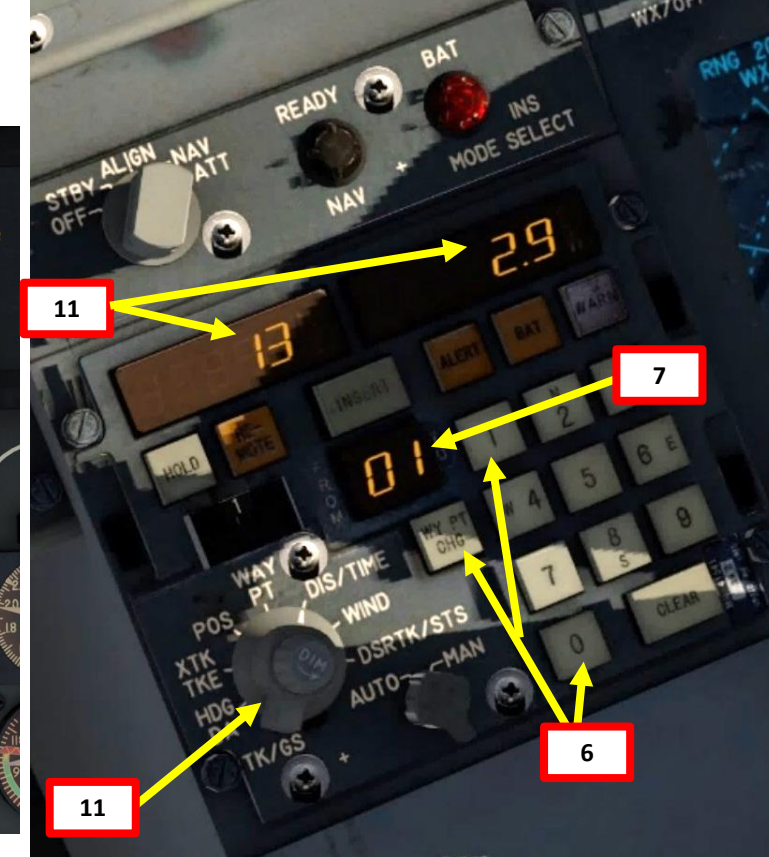

CLIMB

- 12. Once you have reached waypoint 1 (SIKBO), press WY PT CHG button, then type "02" on the CIVA keypad. The aircraft will then track from your current location to Waypoint 2 (HANKK).
- 13. As we can see, the estimated distance is quite similar to what SkyVector gave us. Repeat those steps to track Waypoint 3 (PONCT) and finally Waypoint 4 (KBOS).

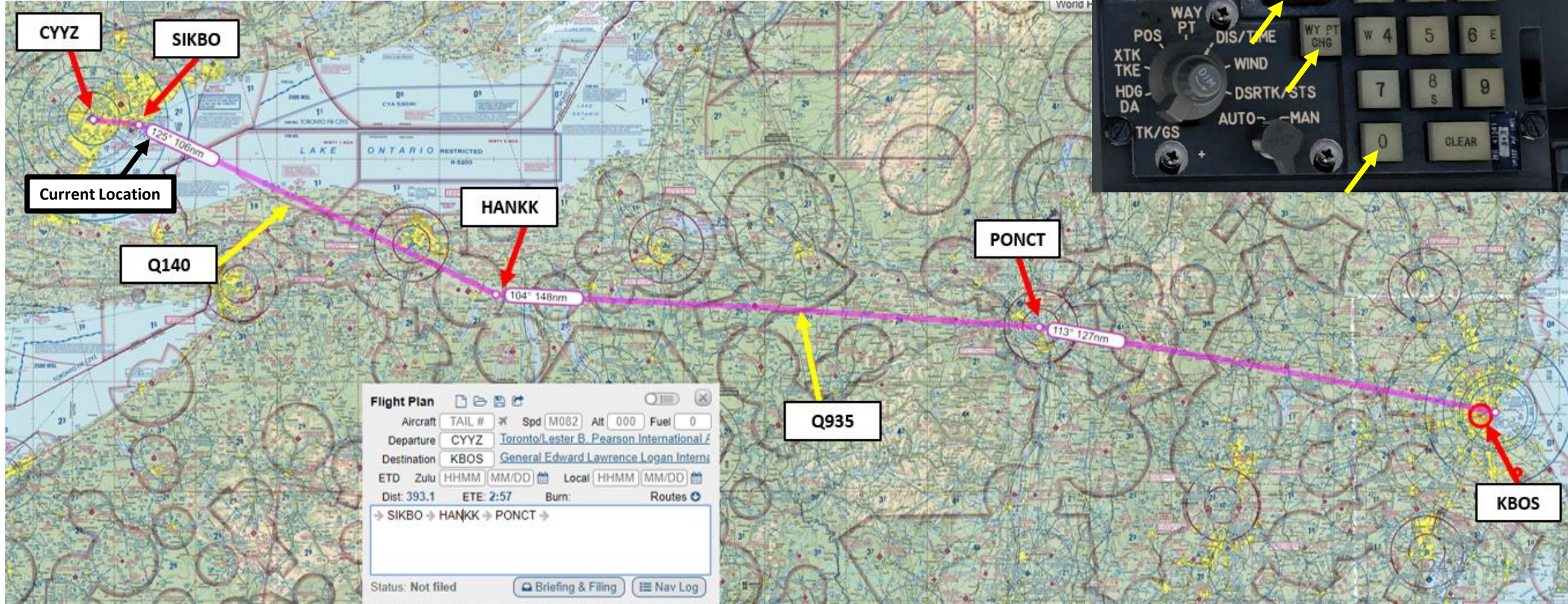



CLIMB

- Once you pass transition altitude (3000 ft in Europe, 18000 ft in the US), adjust altimeter setting to standard barometric pressure (29.92 in Hg). Do it SLOWLY or your autopilot will start freaking out since you are changing his pressure reference. Using STANDARD pressure is done in order to use flight levels as a reference. This means you will be using a standard barometric pressure of 29.92 in Hg, which is also used by other aircraft in the airspace instead of a local one given by an Air Traffic Controller. If pilots don't use a "standard" barometric pressure, different aircraft may collide in flight since they don't use the same pressure to define their current altitude. This is why higher altitudes are defined as "flight levels" (i.e. FL330 would be 33000 ft).
- When you reach your cruising ceiling (33,000 ft), the autopilot will automatically set itself in the Altitude Hold mode. The amber ALT SELECT will turn to green, meaning altitude has been captured.

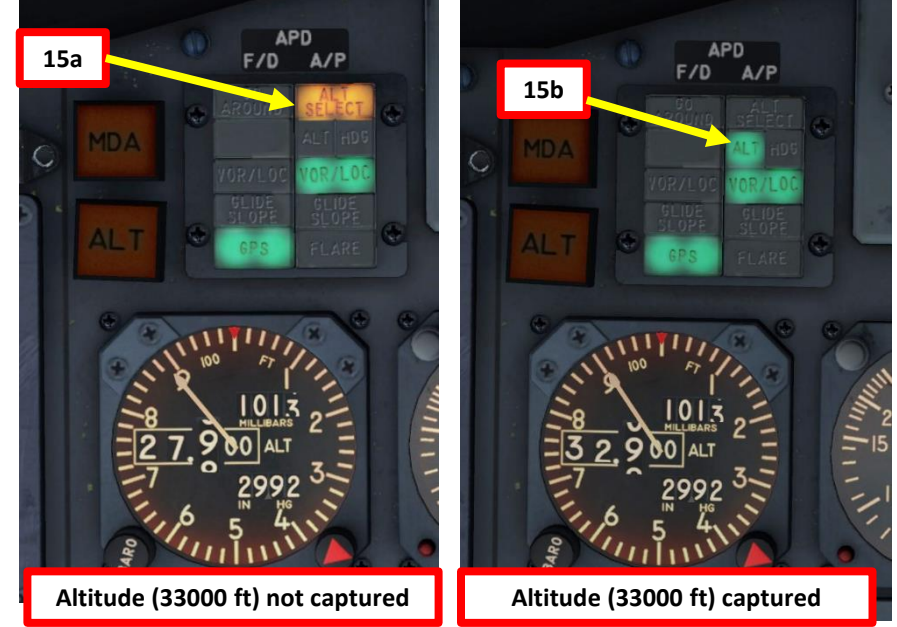

Transition Altitude (U.S. system)

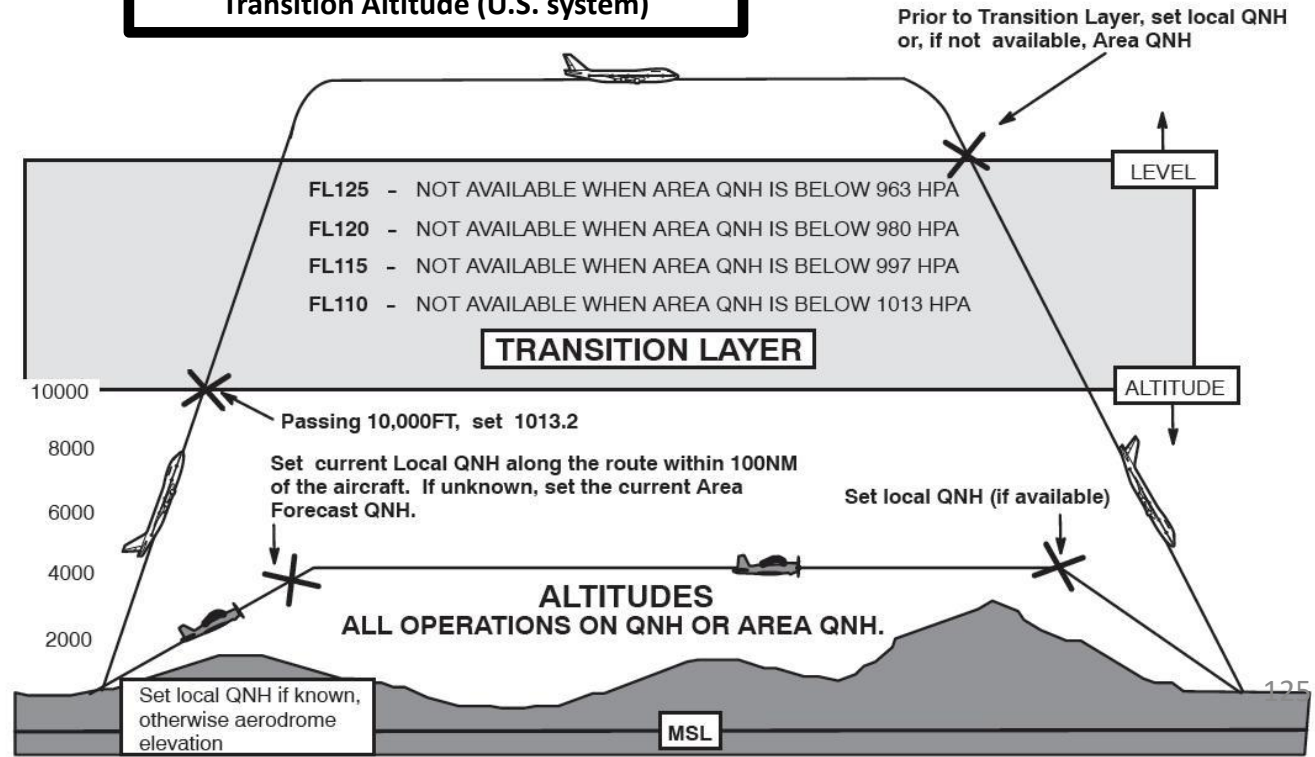

CLIMB

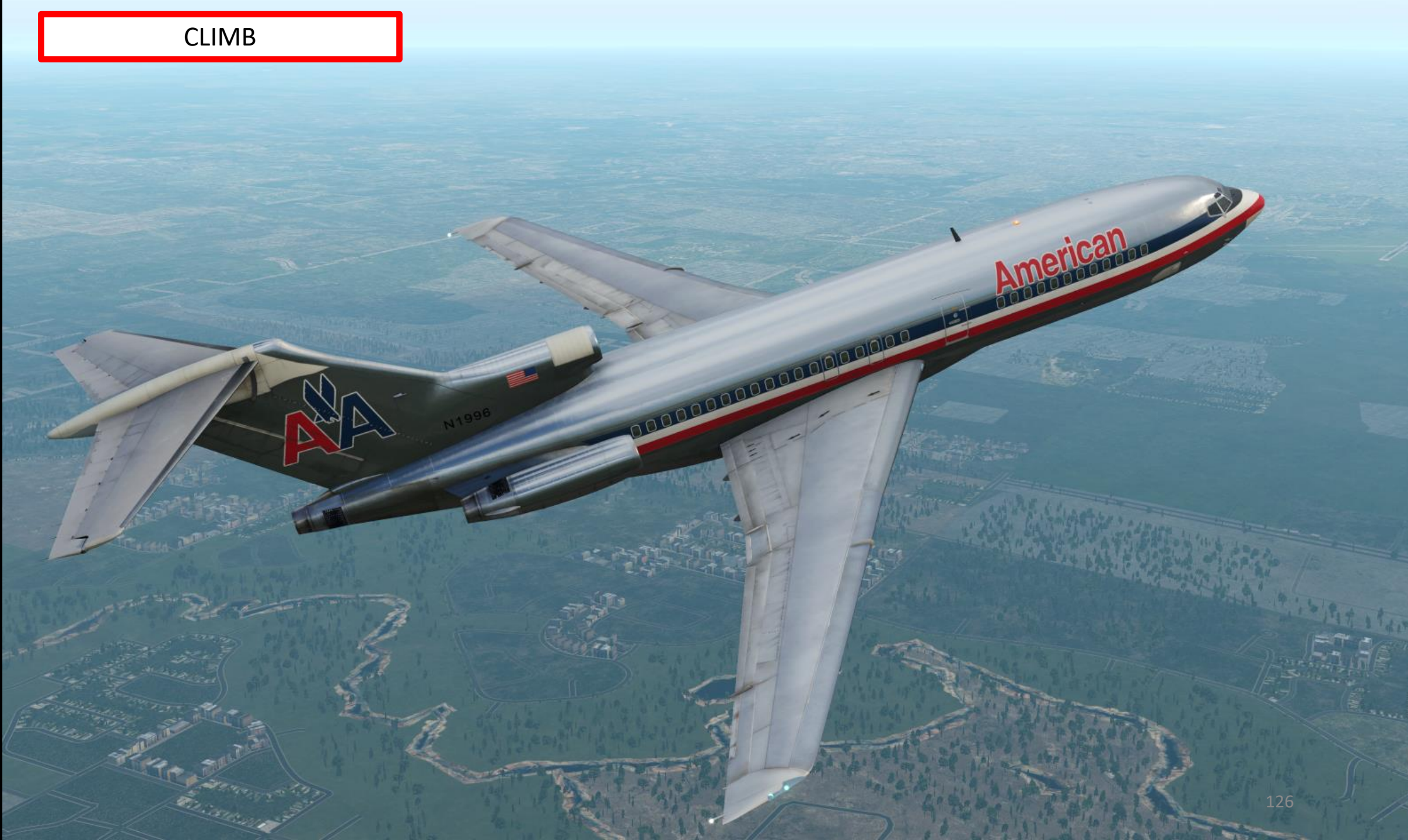

CRUISE

1. When reaching cruising altitude, the autopilot will start levelling off.
2. Once levelled off to 33000 ft, set Airspeed Bug to Mach 0.78.
3. Set Autopilot PITCH SELECTOR to MACH HOLD. The autopilot will now hold a Mach speed of 0.78, meaning that your cruising altitude will vary a little bit to maintain that speed. Keep in mind that you will have to adjust your throttle to control your cruising altitude and keep it constant. (Yep, there is no autothrottle on this bad boy).

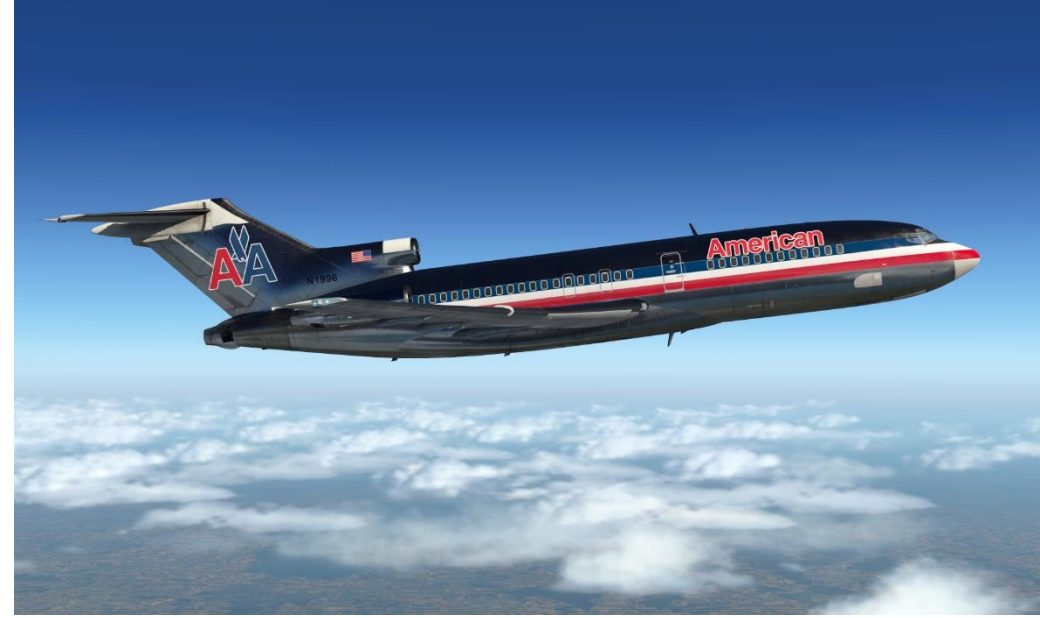

CRUISE

- 4. When you fly over a waypoint, the CIVA will automatically follow the next one. The FROM-TO menu will indicate which leg you are currently following. As an example, the CIVA in the picture to the right shows that we are following the leg from Waypoint 2 (HANKK) to Waypoint 3 (PONCT).

Alternatively, you can use the WY PT CHG technique by typing 0 (your current location) followed by the waypoint number you want to track, as shown before. This method is like a DIRECT TO since it will direct the autopilot directly from your position to the waypoint you want to track.

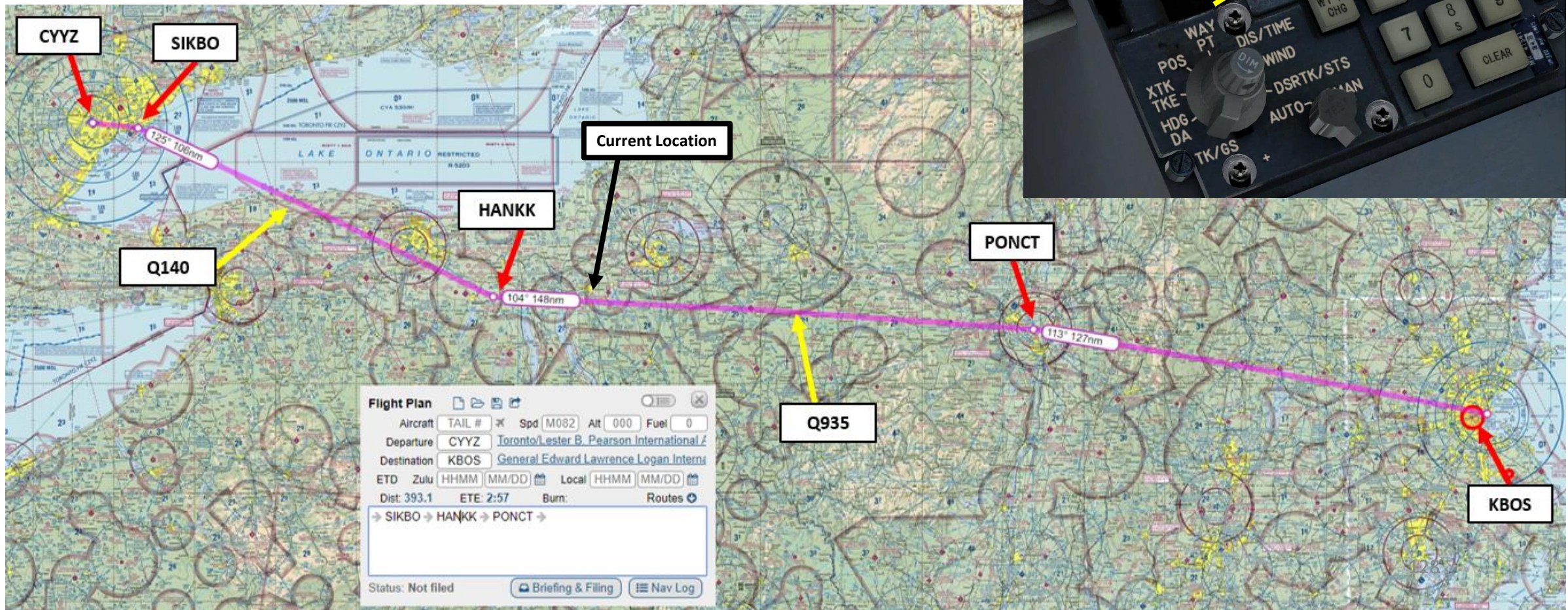

CRUISE

PART 6 – TAKEOFF, CLIMB & CRUISE

727-100

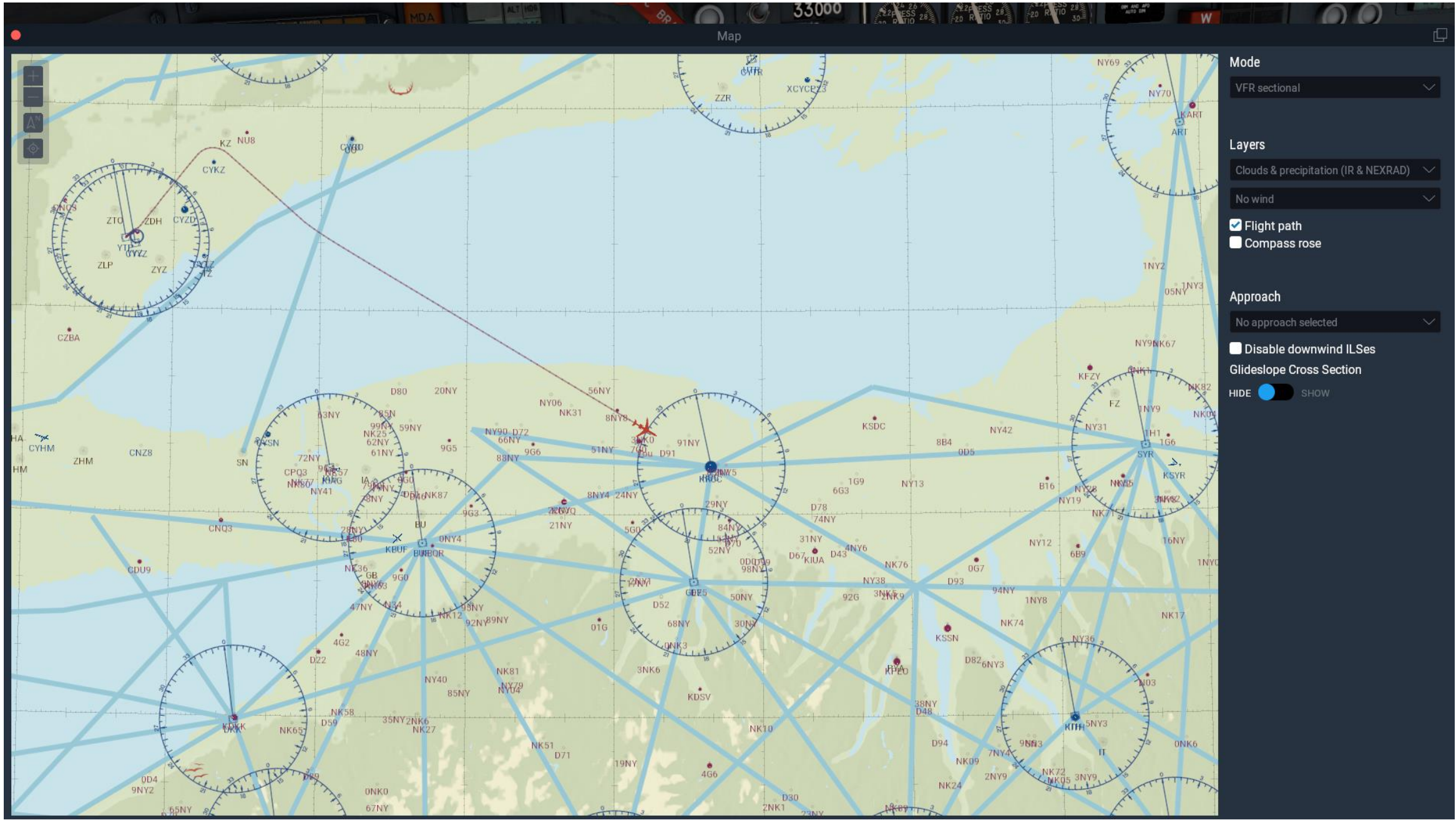

CRUISE



CRUISE



Introduction to Autopilot

Many newcomers in the flight simulation world have this idea that the autopilot is the answer to EVERYTHING. And I mean: e-v-e-r-y-t-h-i-n-g. Spoiler alert: it's not. The autopilot is a tool to help you fly to reduce your workload, not a tool to replace the pilot. The autopilot should be seen as a system that can make your life easier.

Now, why am I saying this? Because *some* people's knowledge of modern autopilot systems is summed up in "hit LNAV and VNAV, then go watch an episode of Mayday while the aircraft does all the work". **Beware!** The Boeing 727 has no ordinary autopilot: it is equipped with the Sperry SP-50. This is old school. Basically, the Sperry will let you control the aircraft laterally and vertically in a number of ways. Keep in mind that there is no auto-throttle system, which means that the aircraft can start abruptly pitching up to increase its angle of attack in order to increase lift if you are asking for a flight parameter (like altitude) to be maintained while not enough power is available to maintain said parameter.

There are three main components to the Autopilot

- The Sperry Autopilot Panel
- The Flight Director
- The APD (Approach Progress Display), which is basically the ancestor of the FMA (Flight Mode Annunciator) installed on modern the Boeing 737 and 747.

APD (Approach Progress Display) for Autopilot (A/P) and Flight Director (F/D)

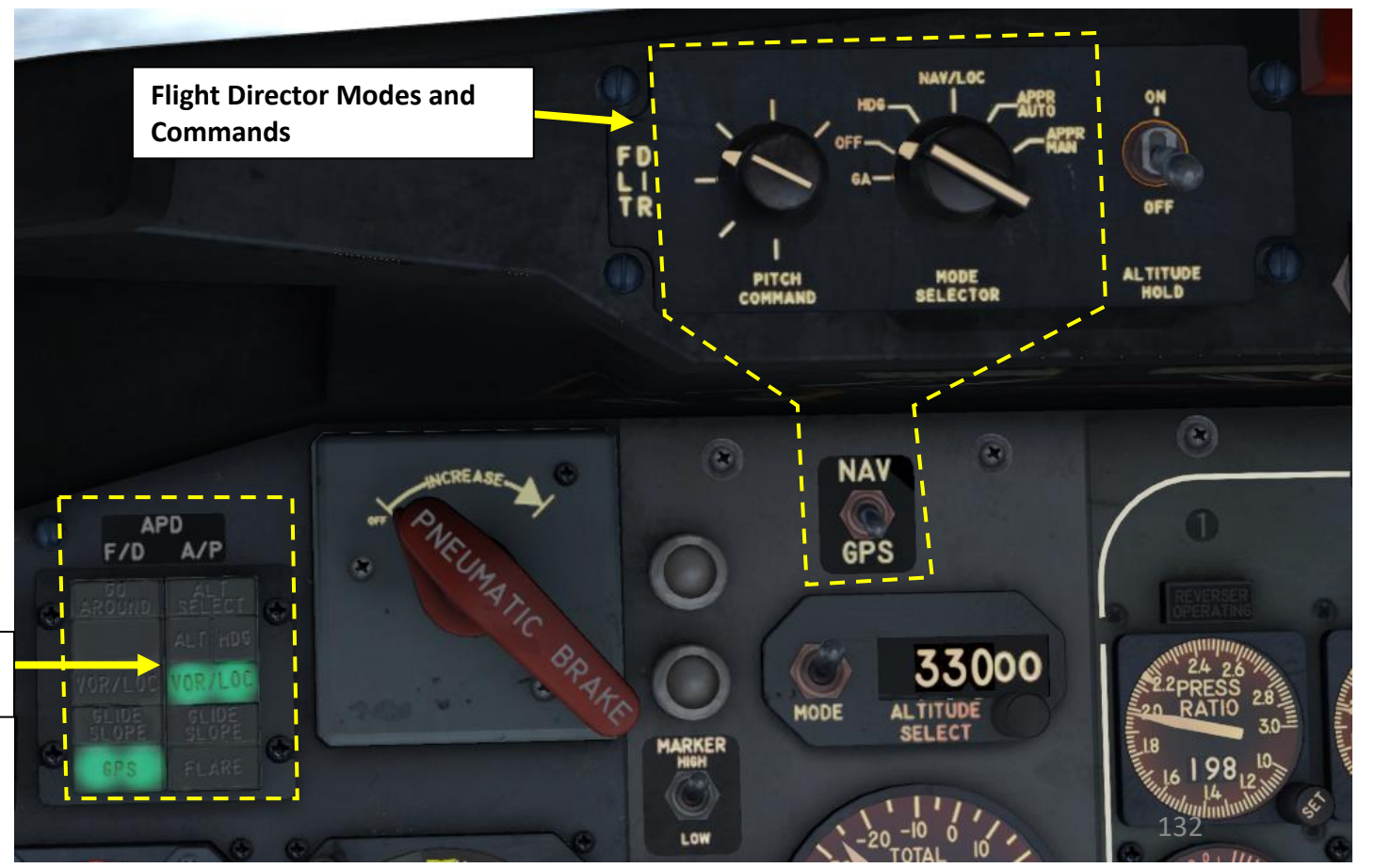

Sperry SP-50 Control Panel

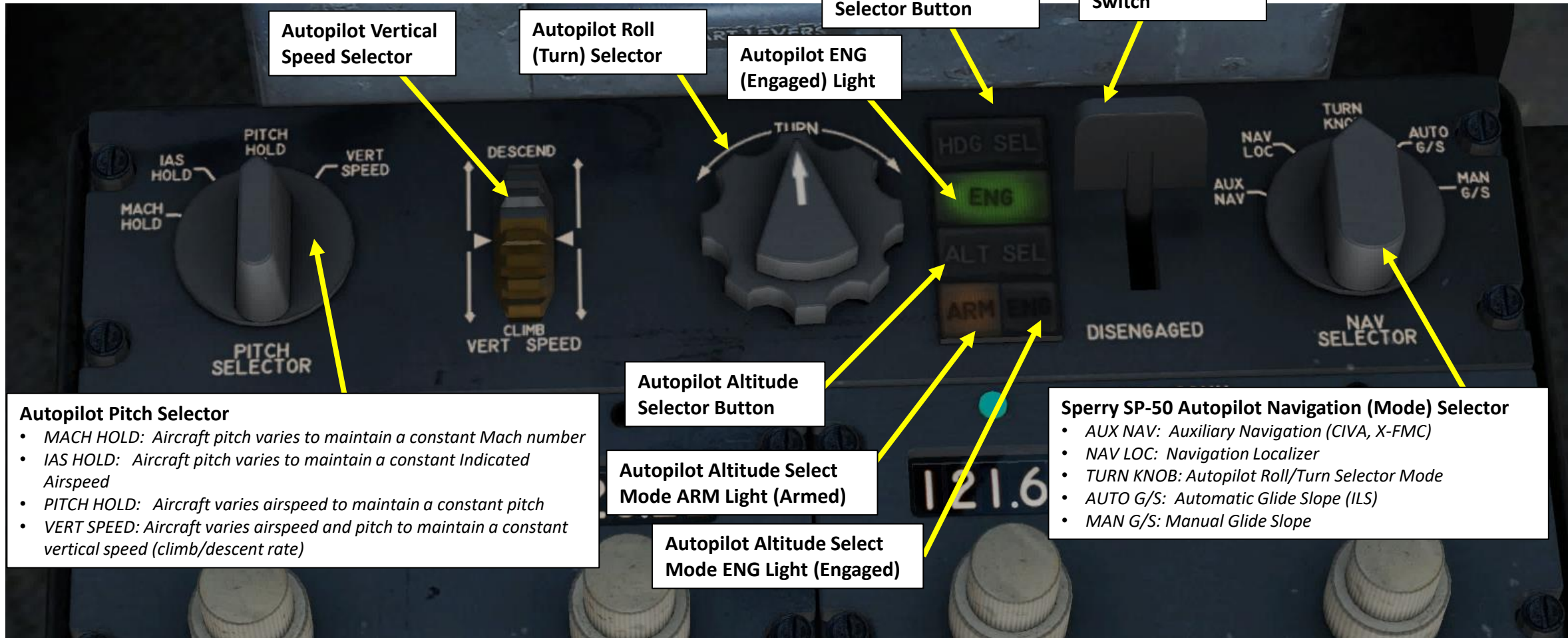

Autopilot Pitch Selector

- **MACH HOLD**: Aircraft pitch varies to maintain a constant Mach number
- **IAS HOLD**: Aircraft pitch varies to maintain a constant Indicated Airspeed
- **PITCH HOLD**: Aircraft varies airspeed to maintain a constant pitch
- **VERT SPEED**: Aircraft varies airspeed and pitch to maintain a constant vertical speed (climb/descent rate)

Sperry SP-50 Autopilot Navigation (Mode) Selector

- **AUX NAV**: Auxiliary Navigation (CIVA, X-FMC)
- **NAV LOC**: Navigation Localizer
- **TURN KNOB**: Autopilot Roll/Turn Selector Mode
- **AUTO G/S**: Automatic Glide Slope (ILS)
- **MAN G/S**: Manual Glide Slope

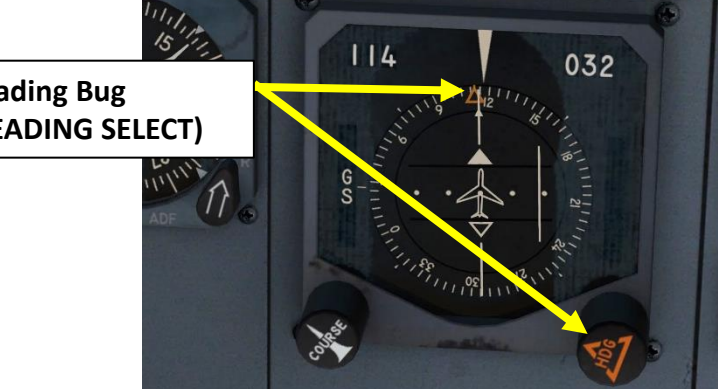
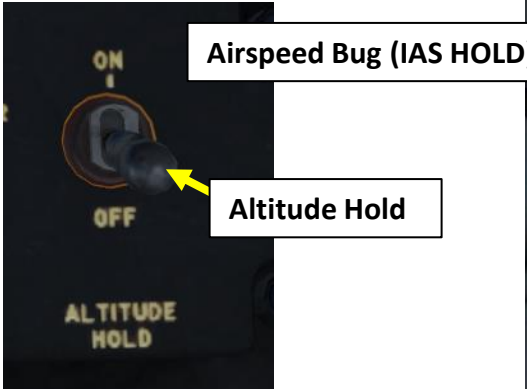
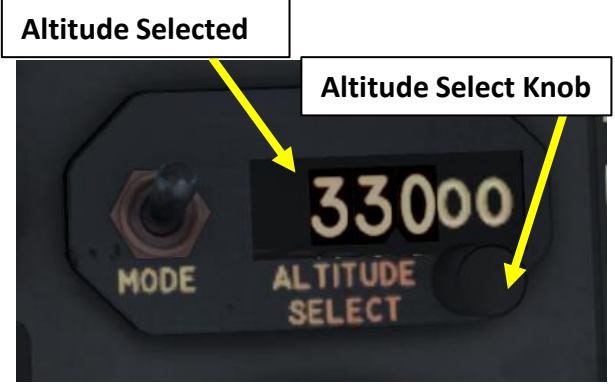

Flight Director Control Panel

Flight Director Pitch Command
Sets aircraft pitch manually

Flight Director Mode Selector
GA: Go-Around
OFF: Autopilot Off
HDG: Heading Select
NAV/LOC: Navigation/Localizer
APPR AUTO: Automatic Approach (ILS)
APPR MAN: Manual Approach

GPS/NAV Selector Switch (added with Version 3)
Selects input to navigation system.
• "GPS" is used for a third-party FMC (Flight Management Computer) or CIVA (Delco Carousel IV-A).
• "NAV" is used for VORs set up on the NAV radio-navigation radios.



APD (Approach Progress Display)

Autopilot Mode	Description
IAS/MACH HOLD	Vertical autopilot changes aircraft attitude to hold indicated airspeed or Mach Number
VERT SPEED	Vertical autopilot changes aircraft attitude to hold vertical speed
PITCH HOLD	Vertical autopilot maintains aircraft attitude by varying airspeed and altitude
ALT HOLD	Vertical autopilot changes aircraft attitude to maintain current altitude
ALT SELECT	Vertical autopilot changes aircraft attitude to fly to target altitude
GLIDE SLOPE	Vertical autopilot changes aircraft attitude maintain an adequate glide slope on approach (requires an ILS)
HDG	Lateral autopilot tracks selected heading
GPS/AUX NAV	Lateral autopilot tracks auxiliary navigation systems like CIVA or FMS waypoints
VOR/LOC	Lateral autopilot arms autopilot to capture and track a selected VOR or LOC course.

VERTICAL MODE

LATERAL MODE

**APD (Approach Progress Display) for Autopilot (A/P) and Flight Director (F/D)**

- GO AROUND
- ALT SELECT
- ALT (Altitude Hold)
- HDG (Heading Hold)
- VOR/LOC (Localizer)
- GLIDE SLOPE
- GPS
- FLARE

Note: Amber means ARMED (as in trying to capture a localizer), Green Means CAPTURED (as In Glide Slope is captured).

PLANNING DESCENT

So, you've finally made it all the way up to your cruising altitude? Congrats! Now, we have a bit of planning to do.

First, let's introduce you to the ILS (Instrument Landing System). This system exists to guide you during your approach.

- The Localizer is generally an array of antennas that will give you a lateral reference to the center of the runway.
- The Glide Slope station will help you determine the descent speed you need in order to not smack the runway in a smoldering ball of fire.



Localizer Array Station at Hannover

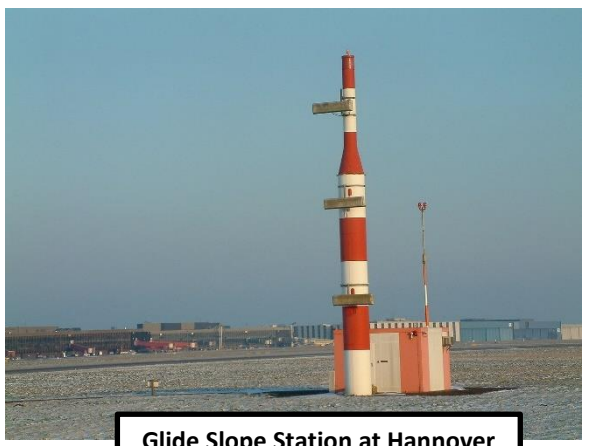

Glide Slope Station at Hannover

Great video explanation of ILS
<https://www.youtube.com/watch?v=KVtEfDcNMO8>

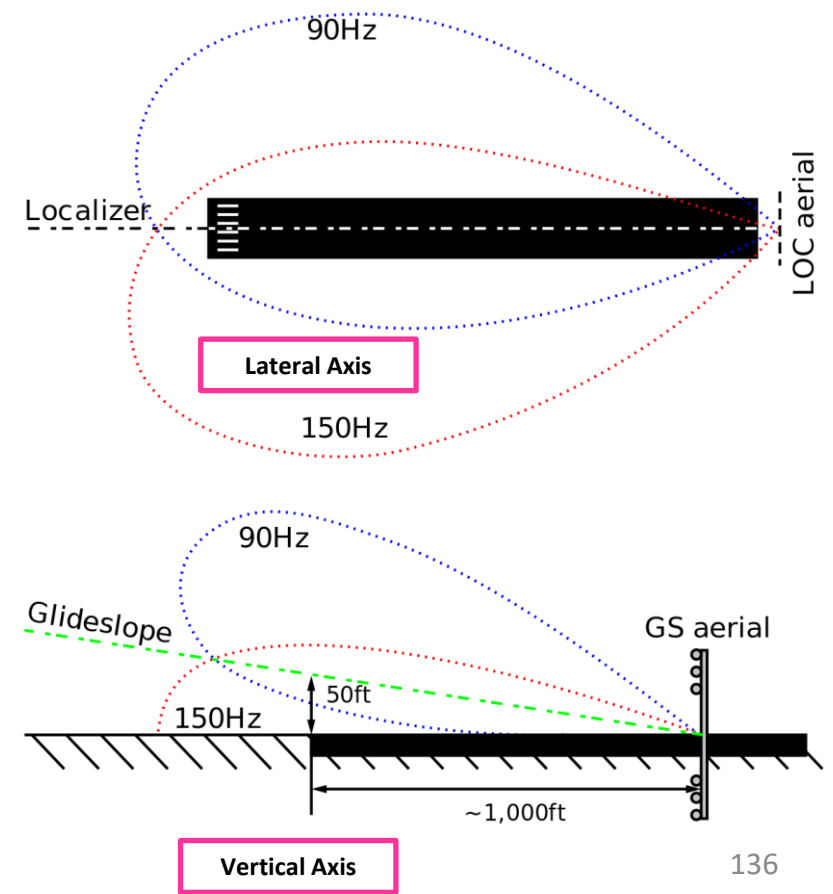
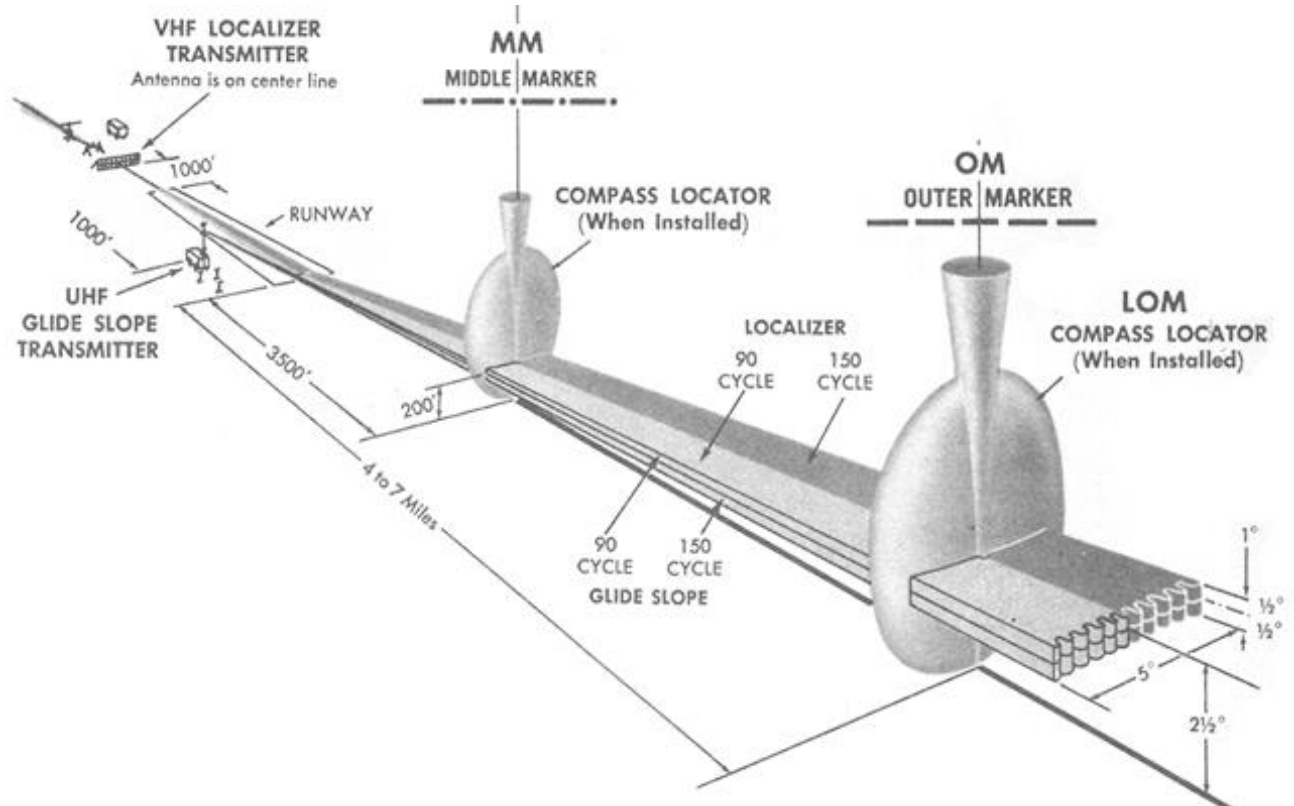

PLANNING THE APPROACH - STAR

These charts are for the STAR (Standard Terminal Arrival Route) from PONCT to Boston Logan International Airport (KBOS). This STAR is a little complicated for those not used to land by tracking VORs, so we will simplify it a little. We intend to:

1. Come from PONCT waypoint
2. Fly from PONCT towards the GARDNER FOUR arrival route via PONCT -> ALB.
3. Follow the STAR (ALB -> GDM -> BOS)
4. Follow the approach towards the runway, guided by the KBOS airport's ILS (Instrument Landing System).
5. Land at Boston (KBOS) on runway 22L (orientation: 215 Left)

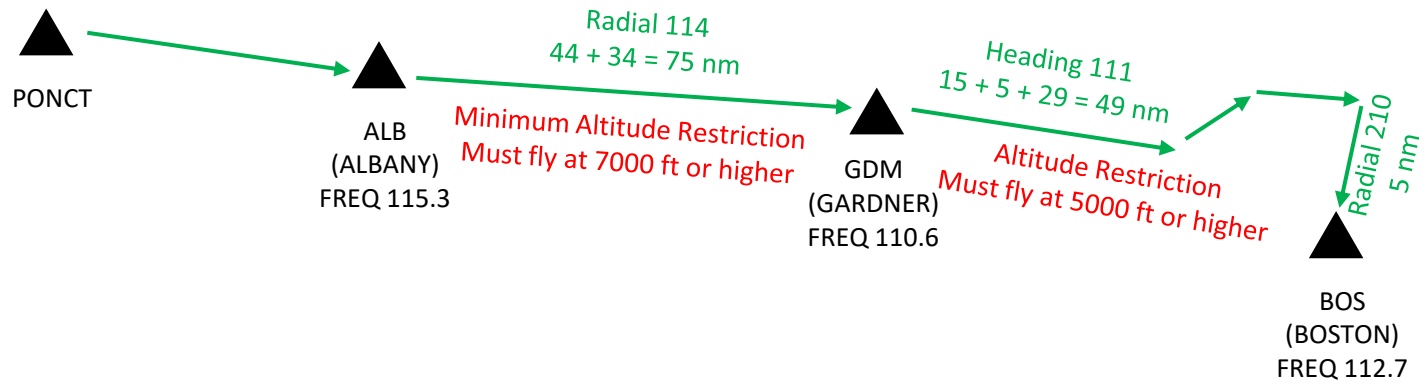
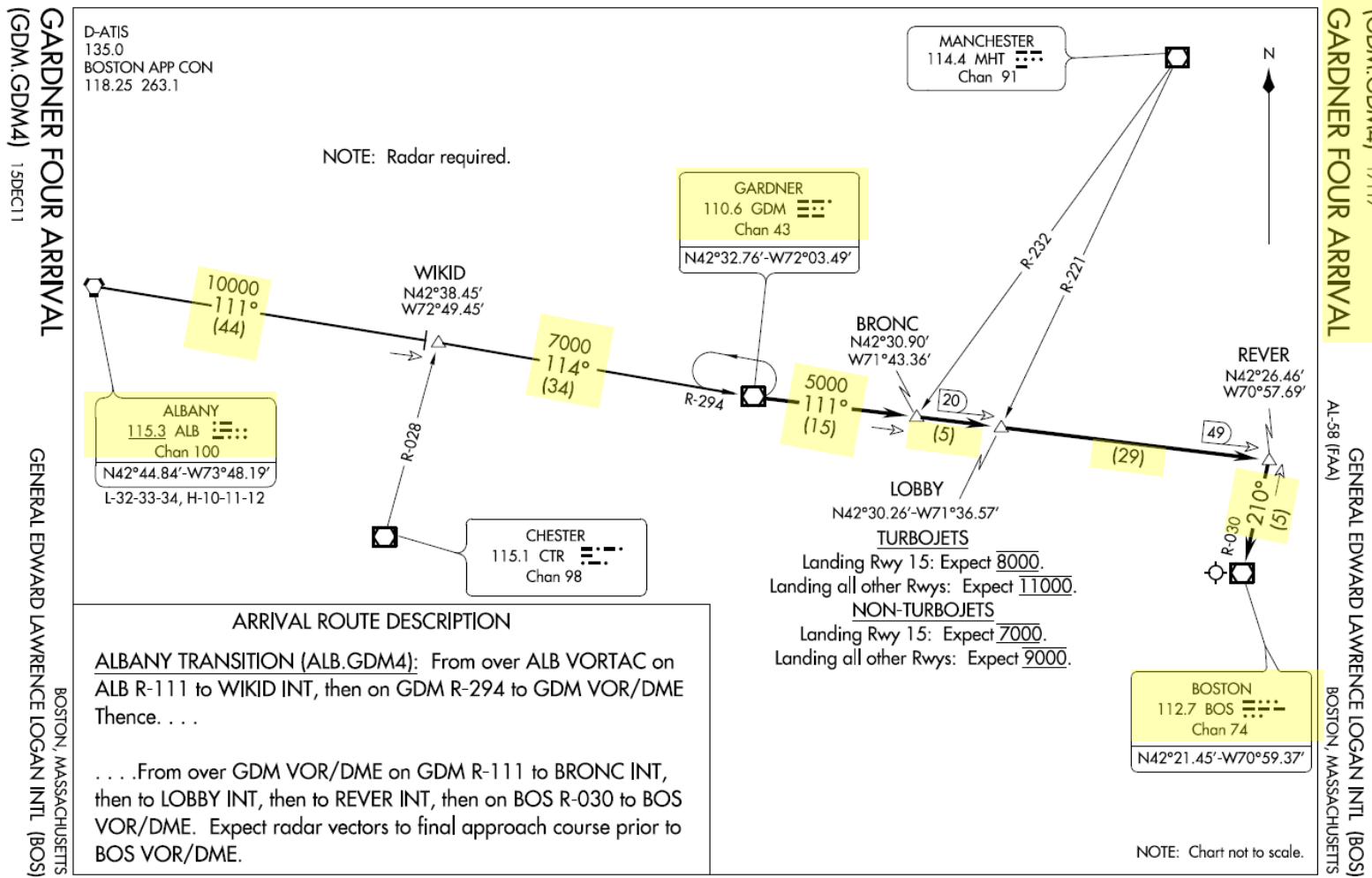

PLANNING DESCENT

Final Approach Course: 215
 This is the heading you will take when approaching for final landing.

Minimums Decision Height: 200 ft
 This is the minimum "decision height" (DH) during landing. If you go lower than 200 ft above ground level, you are committed to land no matter what happens. Above 200 ft, you can still miss your approach and go around. Take note of the Airport Elevation (19) and the TDZE (Touchdown Zone Elevation) of 16 ft.

ILS Frequency: 110.3 MHz
 This is the ILS system frequency you will track to guide your aircraft for landing.

ATIS Frequency: 135.0
 The ATIS (Automatic Terminal Information Service) will provide you valuable information including wind direction and speed, and the altimeter setting required for landing.

Missed Approach Standby Frequency: 112.7 MHz
 VOR BOS will be the beacon we will track in case we miss our approach and have to go around.

Missed Approach Procedure
 In case we miss our approach, the procedure is to climb to 3000 ft then follow the BOS VOR and hold.

Here is a great link to know how to read these charts properly:
<https://community.infinite-flight.com/t/how-to-read-an-approach-chart/8952>

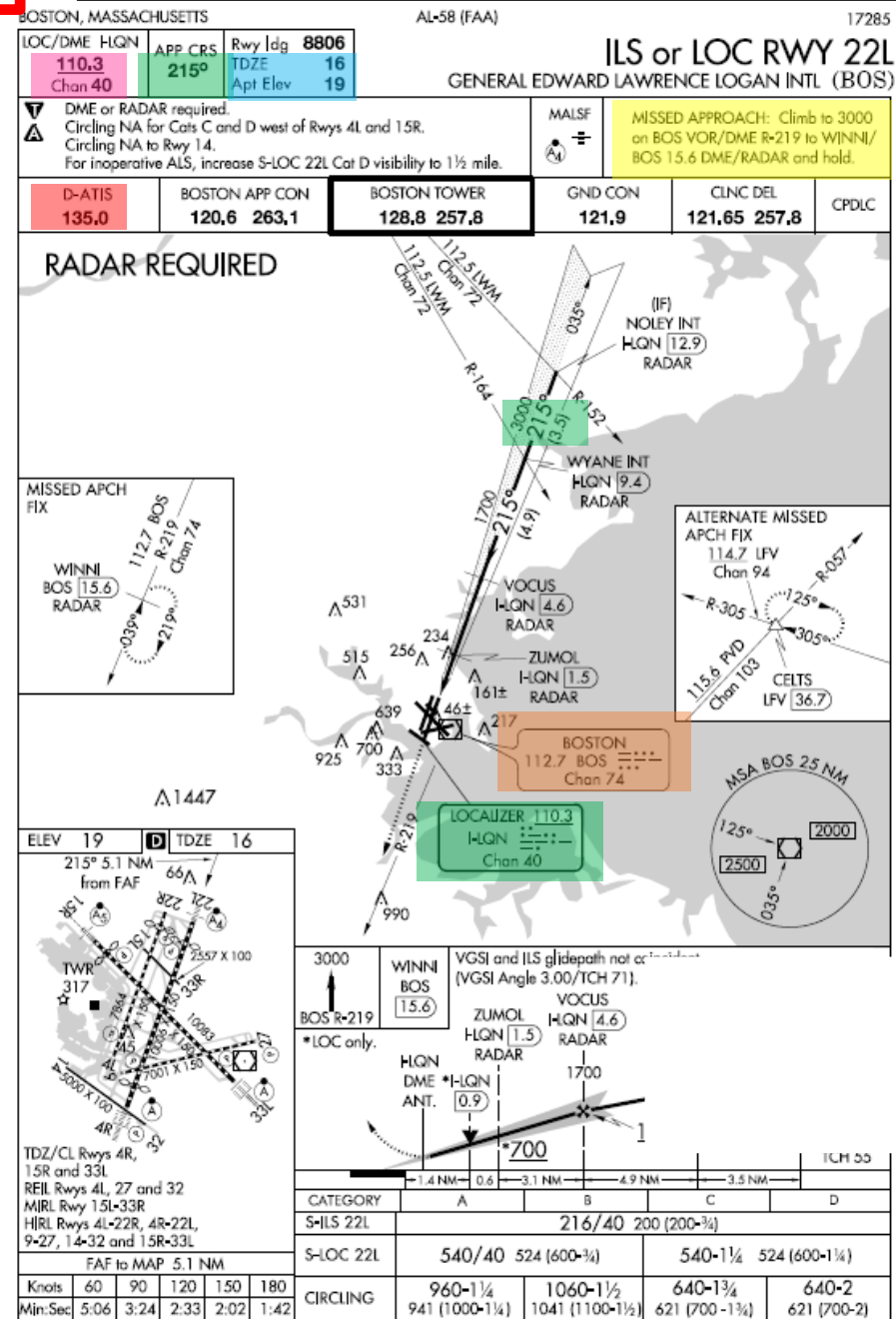
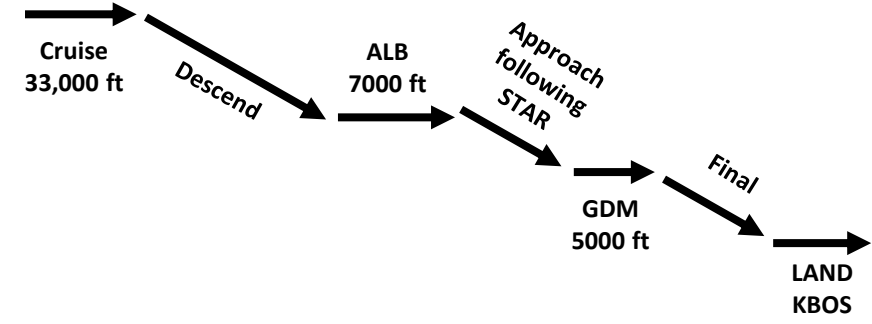

PLANNING DESCENT

1. So we are finally approaching Boston by following leg 34 on the CIVA (PONCT-KBOS). For descent, we will track VORs instead of CIVA waypoints since they are easier to track and the CIVA has accumulated drift during the flight, which will make the approach more difficult than it needs to be.

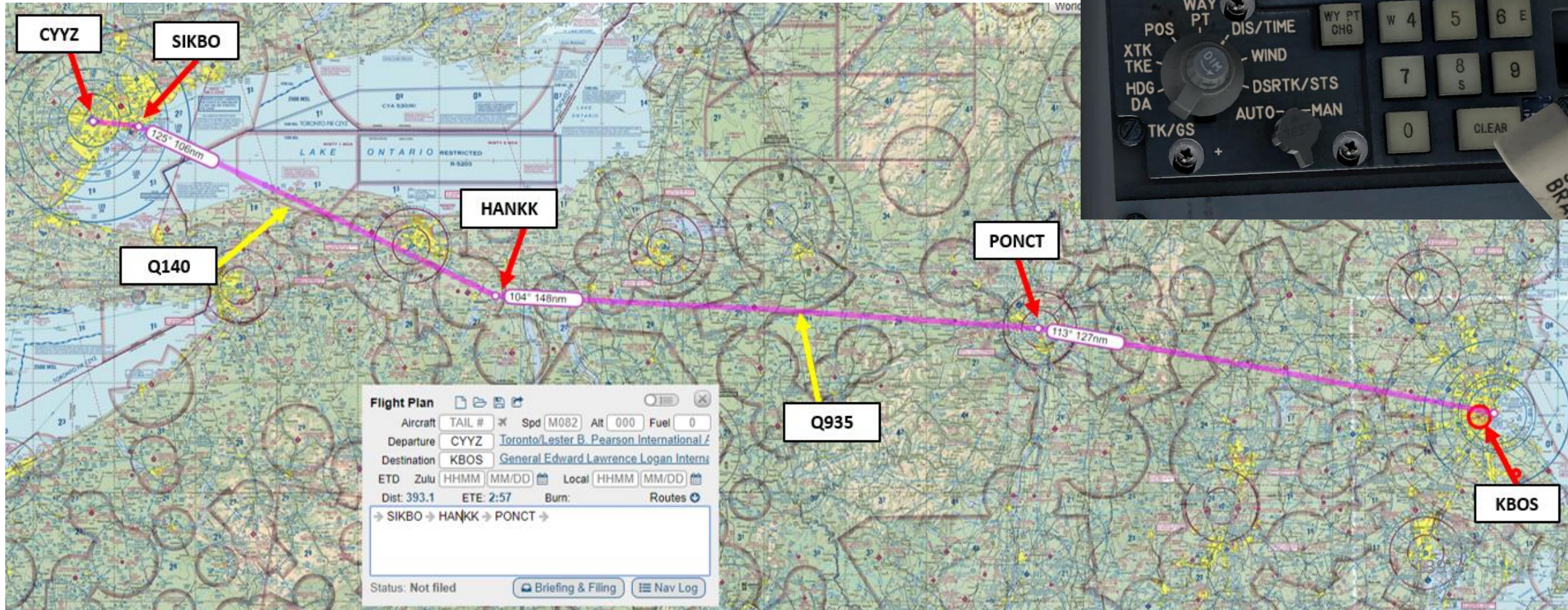

PLANNING DESCENT

- Set VHF-1 NAV Active frequency to 115.3 (ALBANY VOR) and set the VHF-1 NAV Standby frequency to 110.6 (GARDNER VOR).
- Set VHF-1 COMM Radio Active frequency to 135.0 (Logan International ATIS).

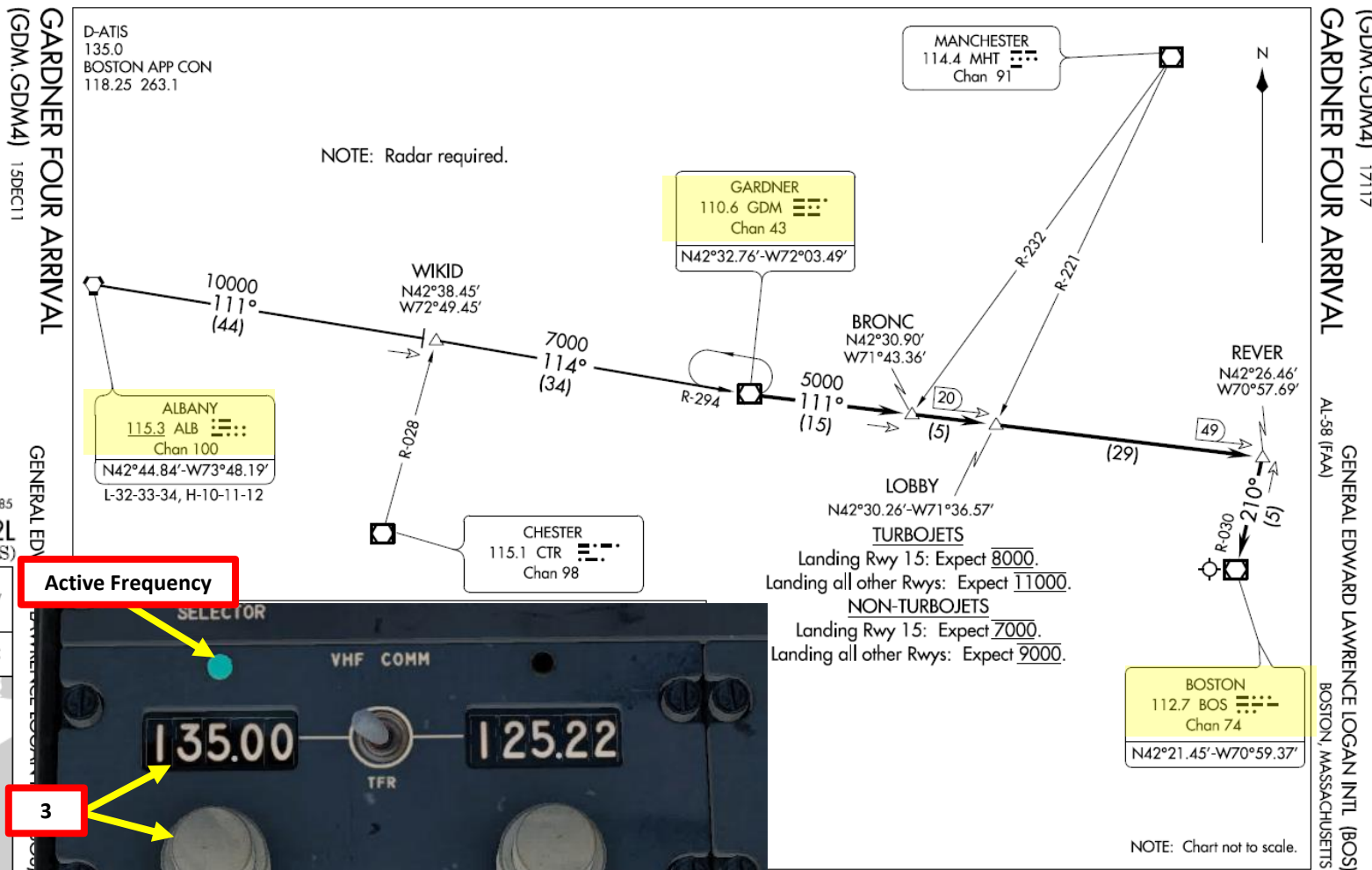
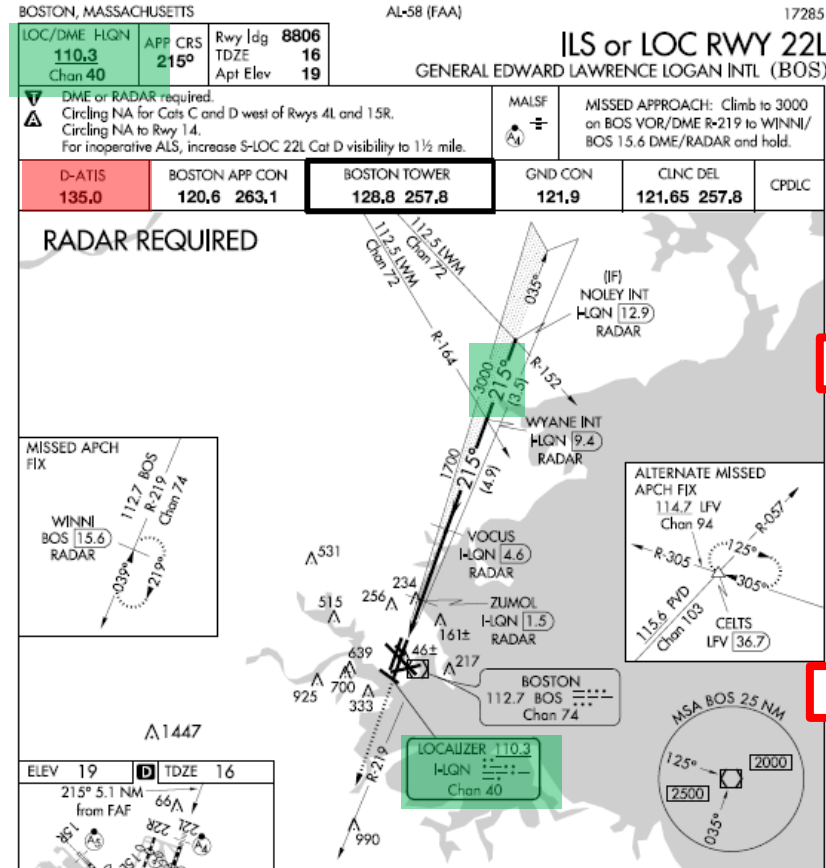

PLANNING DESCENT

4. Set the GPS/NAV Selector Switch set to NAV and also set the NAV SELECTOR to NAV LOC to make the autopilot track the VOR instead of the CIVA waypoints.
5. Set the Flight Director Mode Selector switch to NAV/LOC.
6. Set a course of 111 on the HSI (Horizontal Situation Indicator) to approach the ALBANY VOR from a heading of 111 degrees.
7. The VOR LOC will be amber when the localizer is not captured, and it will turn to green when localizer is captured.
8. Distance from VOR ALB (ALBANY) is displayed on the HSI (Horizontal Situation Indicator). On this image, we are about 25 nm from ALB.
9. Set airspeed bug to descent speed of 250 kts.
10. Set PITCH SELECTOR to IAS HOLD. The aircraft will try to maintain this speed during descent.
11. Set ALTITUDE SELECT to 7000 ft (ALB minimum altitude restriction).
12. Arm the ALT SEL mode on the Autopilot control panel.
13. Set throttles to IDLE and start descent.



ALT SELECT (AMBER) =
Selected Altitude Mode Armed
Selected Altitude is not yet captured

VOR LOC (GREEN) =
Localizer is captured!



Distance and Time to CIVA
Waypoint 4 (KBOS Airport)
149 nm / 26.5 minutes

DESCENT

- As you set your throttle to IDLE and start descending, watch carefully the HSI (Horizontal Situation Indicator) and make sure that you are tracking the ALB VOR in the correct direction. The white arrow points towards the tracked VOR beacon. You can also check if the Distance to VOR is decreasing or increasing.

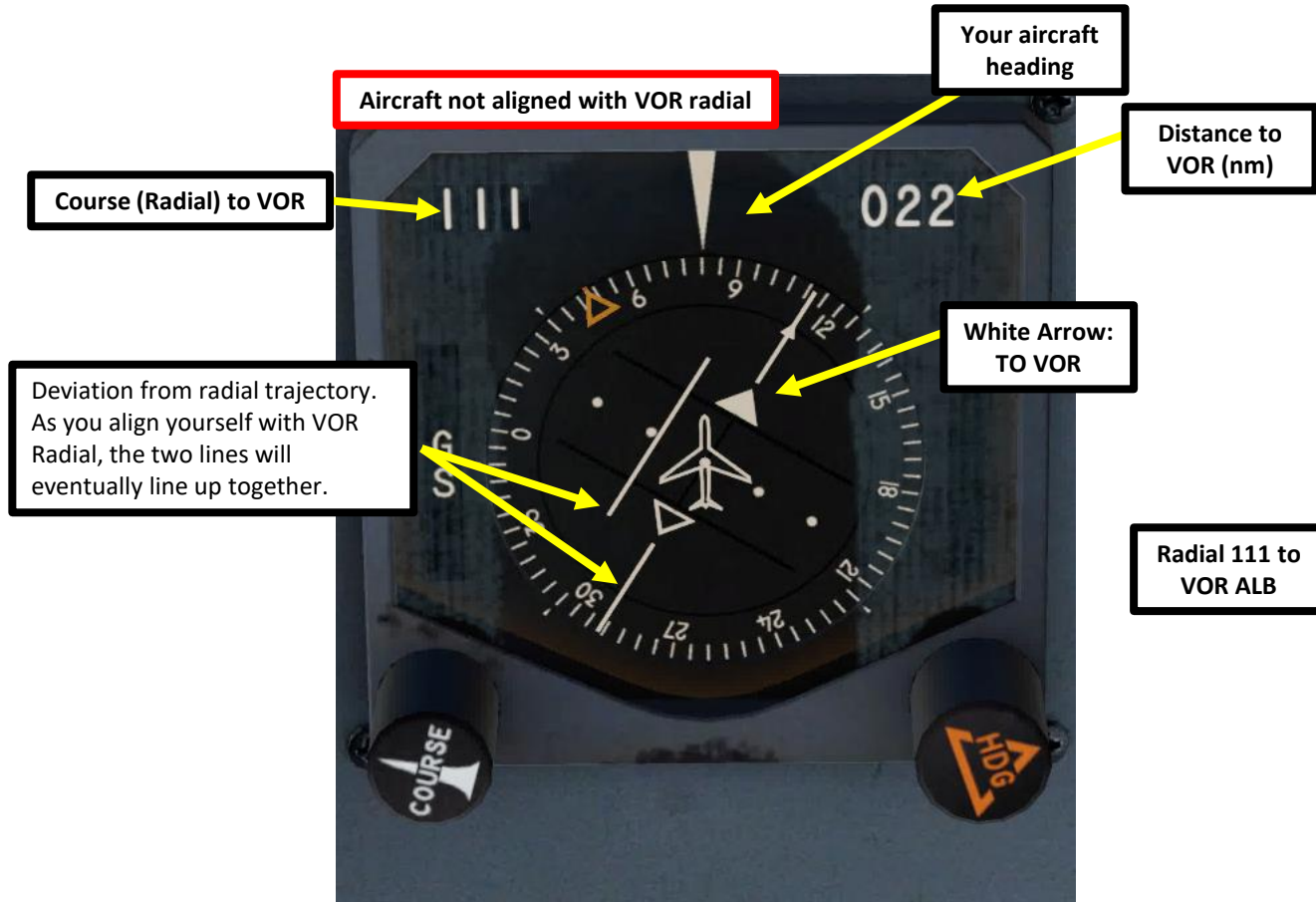

Radial 111 to VOR ALB

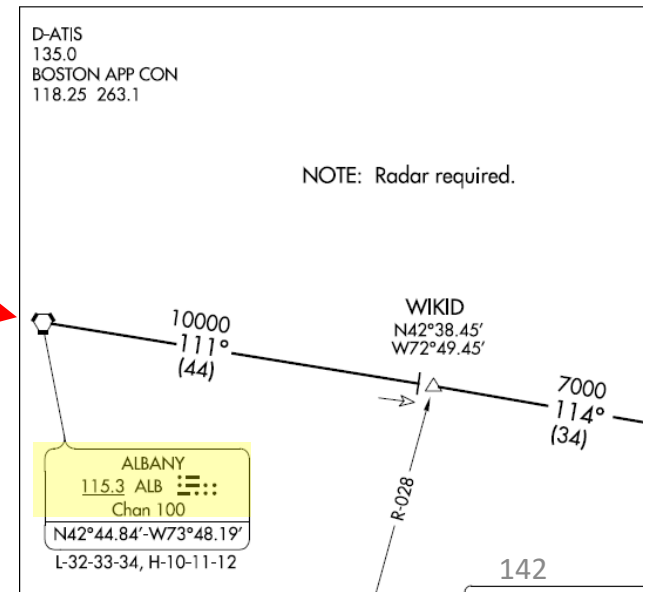

DESCENT

3

2. When reaching the transition level of 18000 ft, set barometric pressure to the altimeter setting specified by the ATIS (30.09 in Hg). Also set the Radio Altimeter bug to 200 ft (Decision Height).
3. Deploy flaps as per flaps schedule.
 - a) Set airspeed bug to 190 kts, wait for the aircraft to slow down, then set flaps to 2 at 190 kts
 - b) Set airspeed bug to 160 kts, wait for the aircraft to slow down, then set flaps to 5 at 160 kts
 - c) Set airspeed bug to 150 kts, wait for the aircraft to slow down, then set flaps to 15 at 150 kts
 - d) Set airspeed bug to 140 kts, wait for the aircraft to slow down, then set flaps to 25 at 140 kts

AFTER TAKEOFF NORMAL MANEUVERING SPEEDS
KTS IAS

FLAPS (DEG)	BELOW MAX LANDING WEIGHT	ABOVE MAX LANDING WEIGHT
0	200	210
2	190	200
5	160	170
15	150	160
25	140	150

NOTE: FOR MANEUVERS IMMEDIATELY AFTER TAKE-OFF EXCEEDING 15 DEG BANK, MAINTAIN AT LEAST $V_2 + 10$ KTS AT TAKE-OFF FLAPS



When reaching 10,000 ft:

4. Landing Lights switches – ON
5. Taxi Light switch – ON
6. Runway Turnoff Lights switches – ON
7. Auto-Brake Switch - MED



2

General Edward Lawrence Logan International information quebec, 15 hundred zulu weather. Wind 1 8 0 at 7, visibility more than 10. Sky clear, Temperature 1 3, dewpoint minus 2 6. Altimeter 30 0 9. Arriving runways 2 2 right, 2 2 left, 1 5 left, departing runways 1 5 right, 1 5 left, 1 4. Advise on initial contact you have quebec.

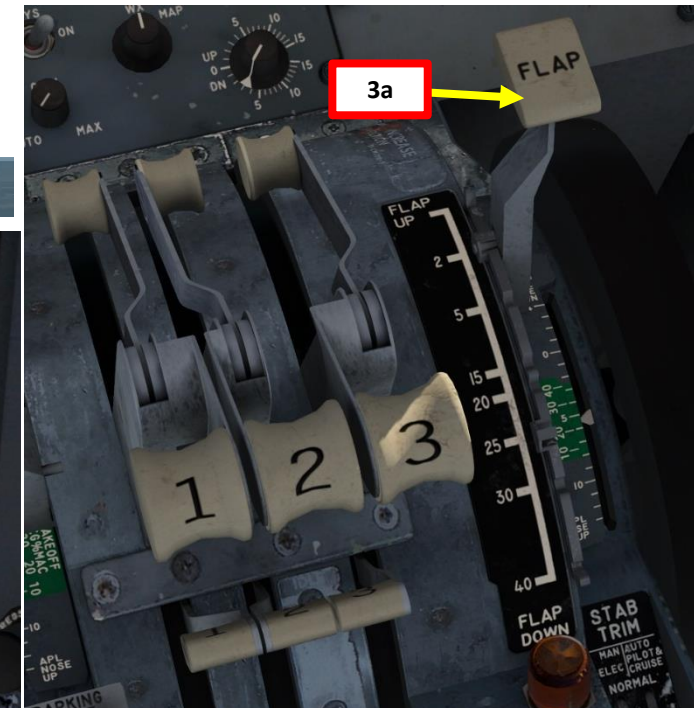
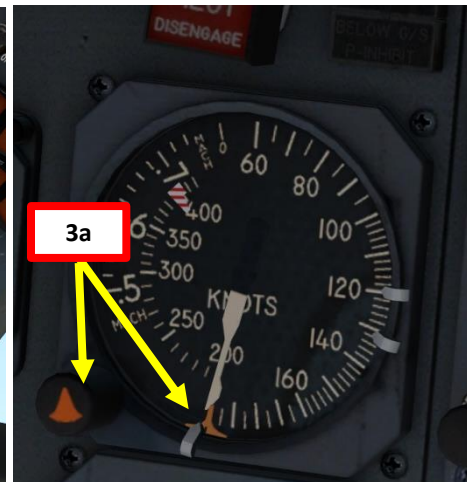
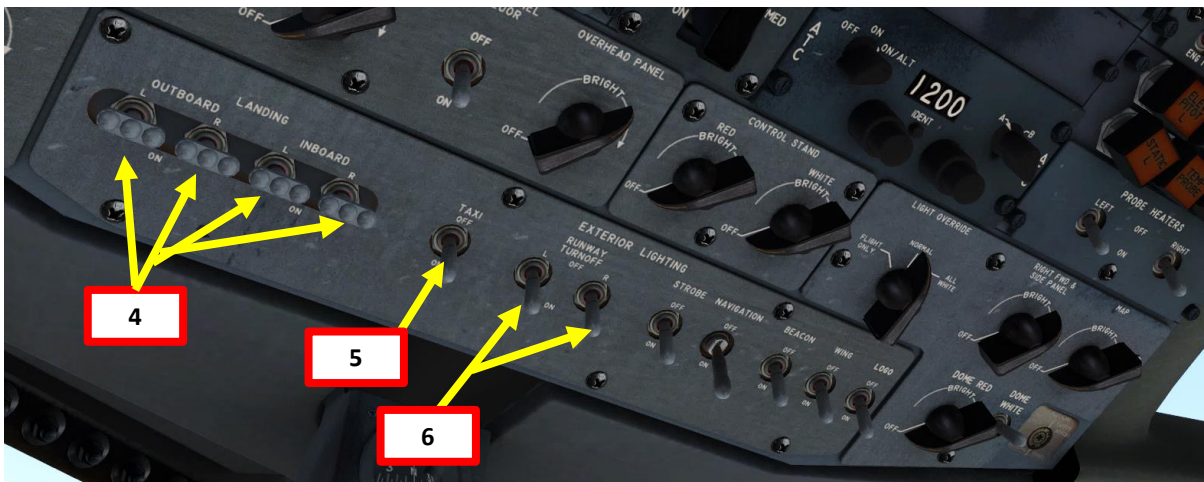



DESCENT

If airspeed is dropping too low, don't be scared to throttle up a little. Once again, the aircraft does not have an auto-throttle... so the aircraft pitch will vary with throttle input and selected autopilot modes, which act on the flight control surfaces. If you're going too fast, using the speed brake lever is also a viable option.

8. When you cross ALB (Albany), don't track the GDM (Gardner) yet. It is too far to be picked up yet. Instead, use the instructions from the chart. We will follow the same heading, overfly ALB, then continue for 44 more miles before switching to GDM.
9. When you are 44 nm FROM Albany with a heading of 111, switch VHF-1 NAV Active Frequency by using the TFR (Transfer) Switch.
10. Set Course to 114 to line up the aircraft with radial 114 to GMD (Gardner) VOR.
11. Set ALTITUDE SELECT to 5000 ft and arm the ALT SEL autopilot mode.
12. Keep controlling your descent rate and attitude with your throttle.

GARDNER FOUR ARRIVAL
(GDM, GDM4) 15DEC11

GENERAL EDWARD LAWRENCE LOGAN INTL (BOS)

D-ATIS
135.0
BOSTON APP CON
118.25 263.1

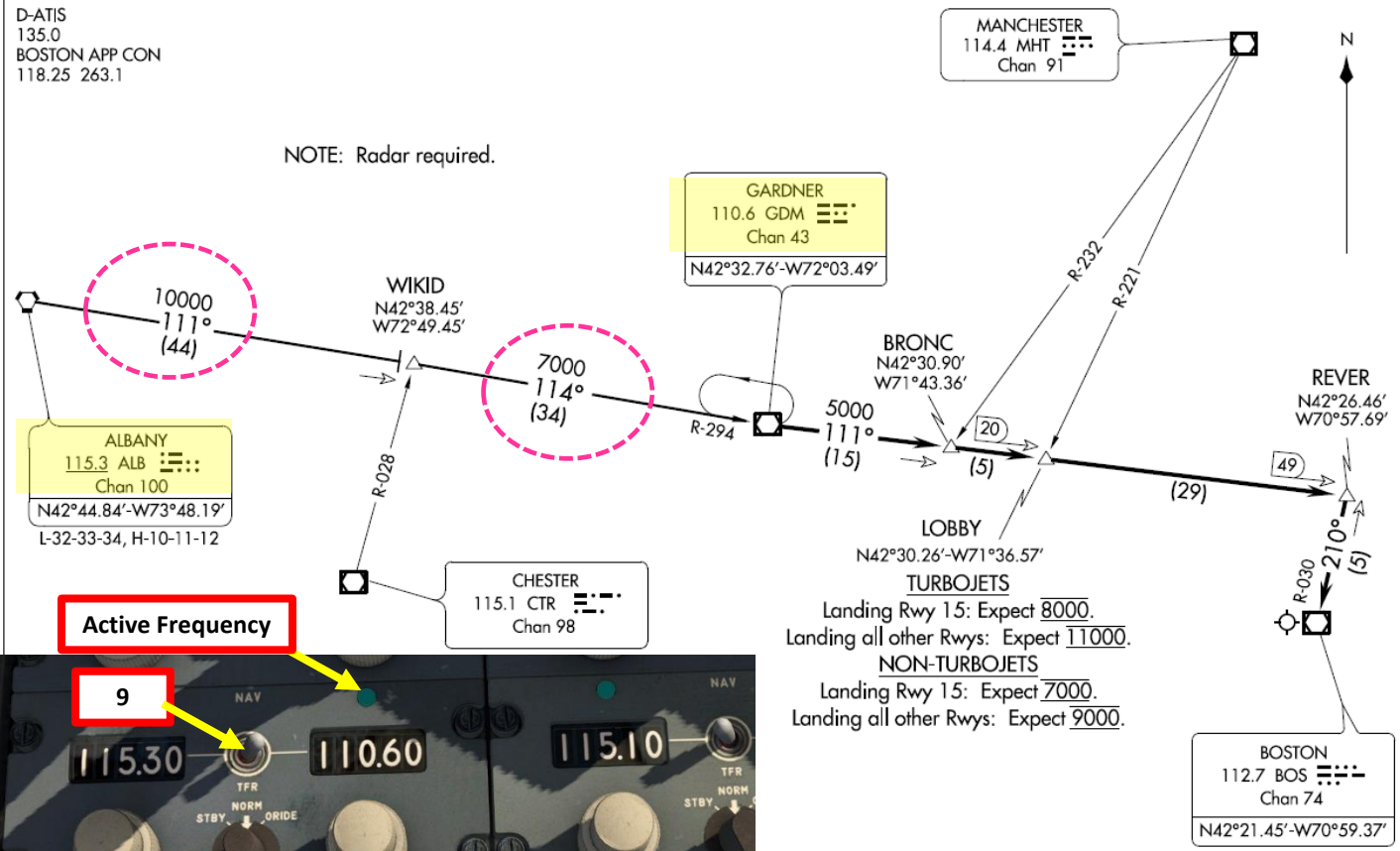

Active Frequency

9

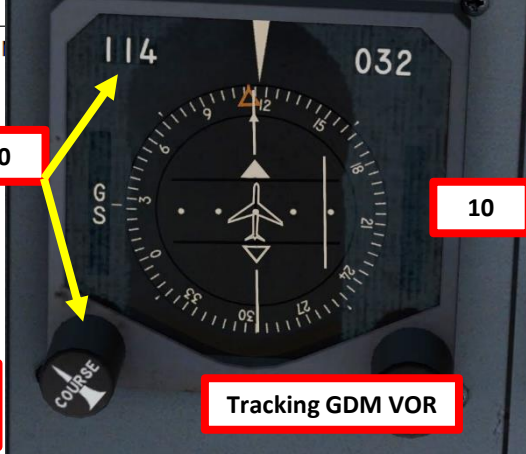
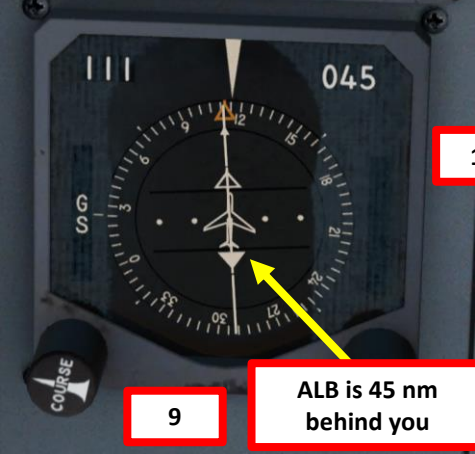

(GDM, GDM4) 17117
GARDNER FOUR ARRIVAL
AL-58 (FAA)
GENERAL EDWARD LAWRENCE LOGAN INTL (BOS)
BOSTON, MASSACHUSETTS

SET UP APPROACH

13. Once you crossed the GDM (Gardner) VOR, set VHF-1 Standby Frequency to 112.7 (BOS, Boston VOR), then use the TFR (Transfer) switch to set it as the active frequency
14. Set Course to 210 to line up the aircraft with radial 210 to GMD (Gardner) VOR.
15. The aircraft will keep its current heading until the aircraft intercepts the BOS radial 210. When the radial is intercepted, the autopilot will steer the aircraft and line it up with the runway.
16. Keep controlling your altitude and attitude with your throttle.

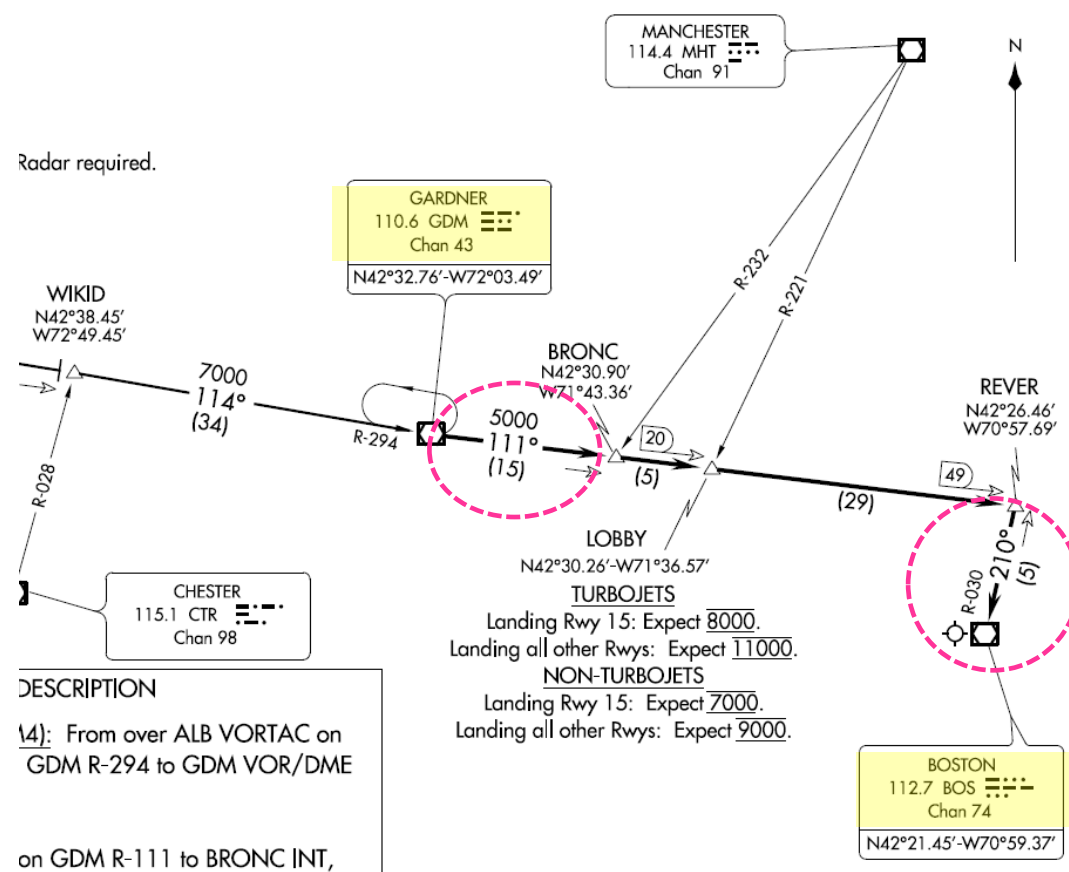
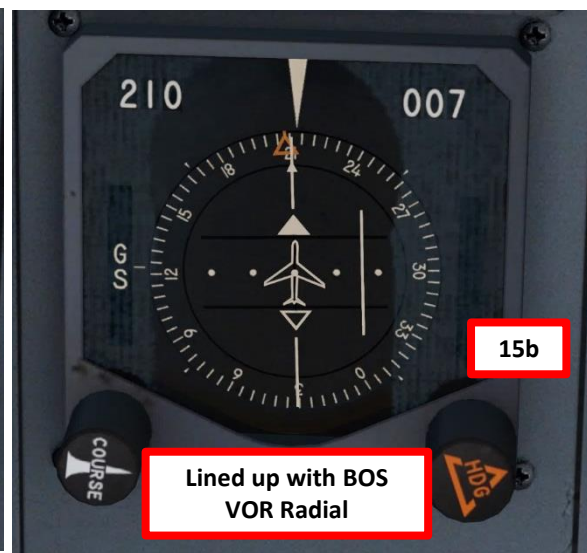



PART 8 - APPROACH & LANDING

SET UP APPROACH

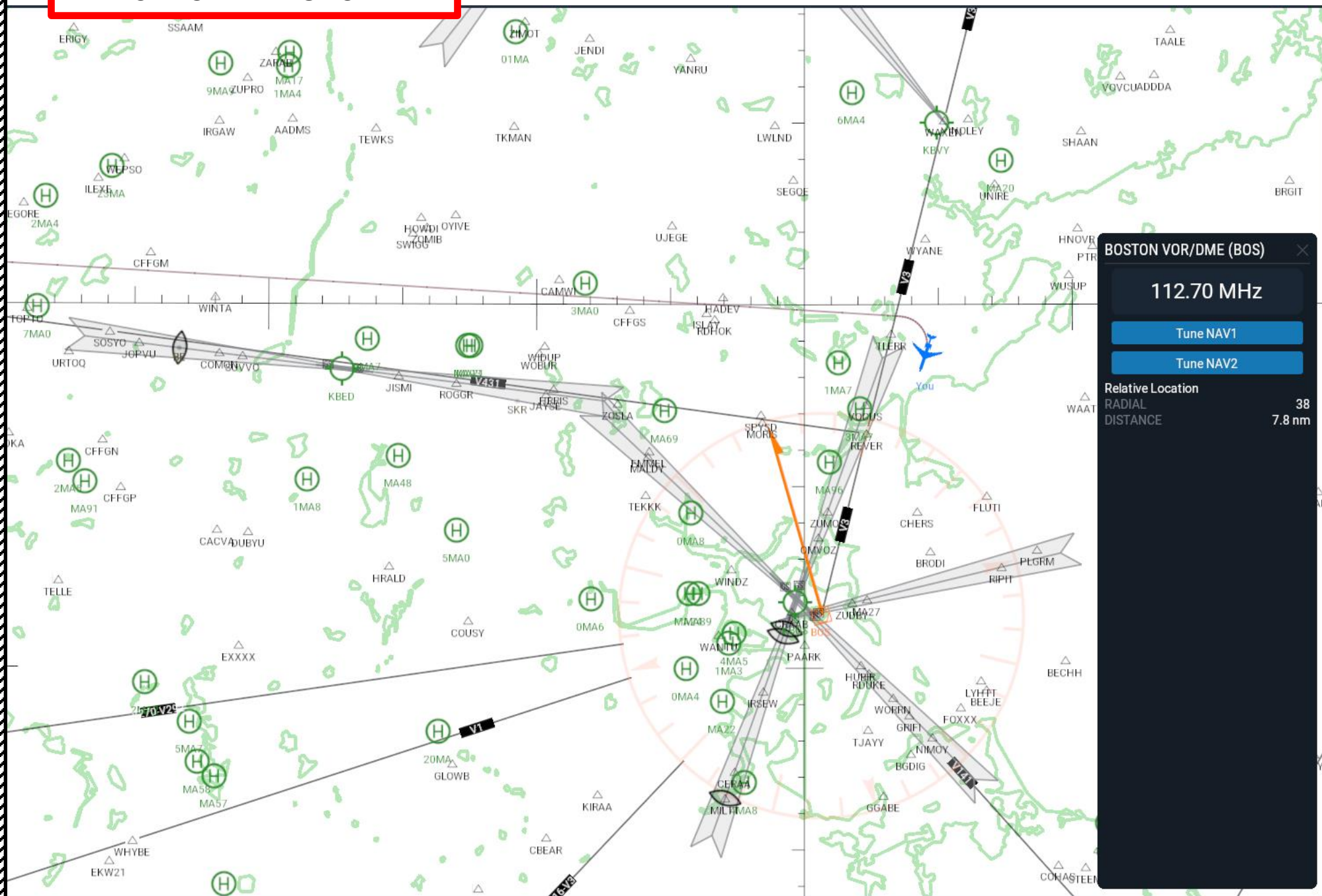

BOSTON VOR/DME (BOS)

112.70 MHz

Tune NAV1

Tune NAV2

Relative Location
RADIAL 38
DISTANCE 7.8 nm

Mode
IFR low enroute

Layers
Clouds & precipitation (IR & NEXRAD)
No wind

Flight path
 Compass rose

Approach
No approach selected

Disable downwind ILSes

Glideslope Cross Section
HIDE SHOW

FINAL APPROACH

1. When the BOS VOR is tracked (VOR/LOC in green), set up the VHF-1 Radio Navigation active frequency to the ILS Localizer frequency (110.3)
2. Set the Localizer Course to 215 as per the ILS chart
3. Set the NAV SELECTOR switch to AUTO G/S (Glide Slope) and make sure the MODE SELECTOR is set to APPR AUTO.
4. VOR/LOC light will be amber when attempting to capture the localizer, and will illuminate in green once localizer is captured
5. GLIDE SLOPE light will be amber when attempting to capture the glide slope, and will illuminate in green once glide slope is captured.
6. Set Landing Gear lever DOWN to deploy landing gear

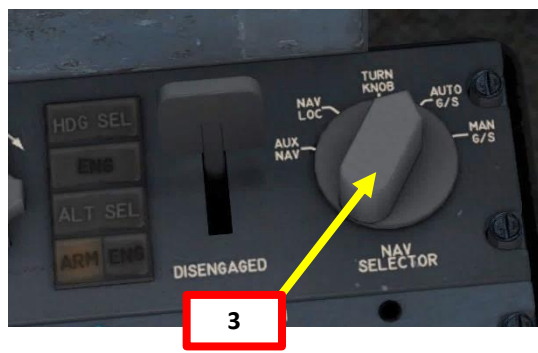
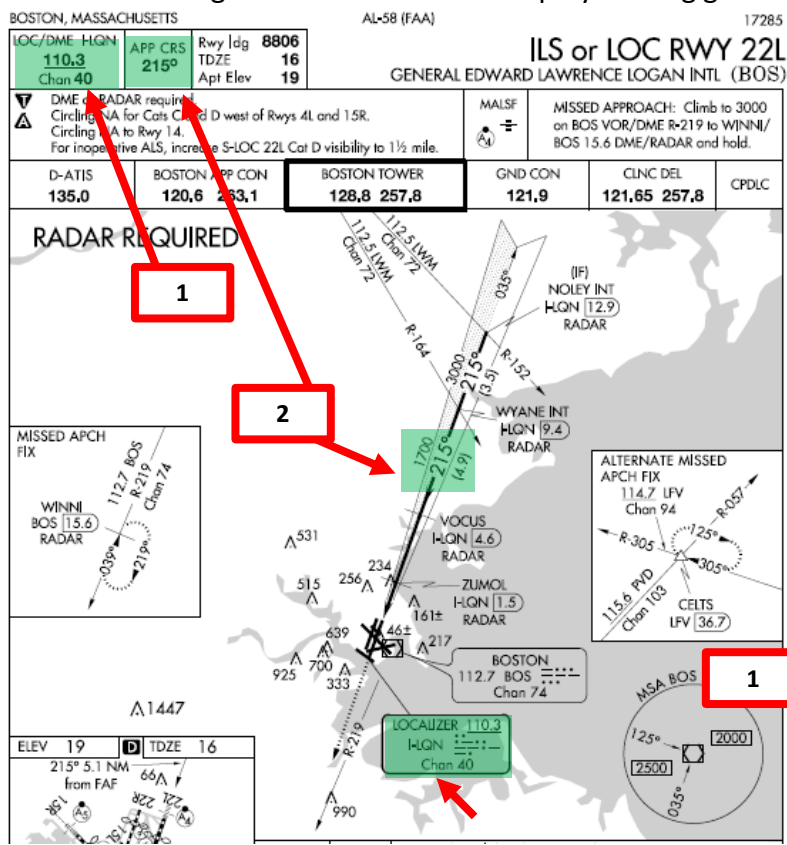

FINAL APPROACH

- Click on the V CARD option button and select the LANDING tab. A recommended landing flaps setting and reference speed will be calculated for you. In our case, we will do our final approach with flaps 30 with an approach speed of 119 kts.
- Use the Airspeed Bug to set the aircraft speed to 119 kts.
- Set flaps to 30 deg when airspeed is stabilized to VREF+5 (124 kts).
- Once localizer (lateral component) and glide slope (vertical component) of approach path are both captured and tracked by autopilot,

NOTE: If for some reason you decide to do a manual landing instead, a good procedure is to disconnect the Autopilot switch and land the aircraft visually.

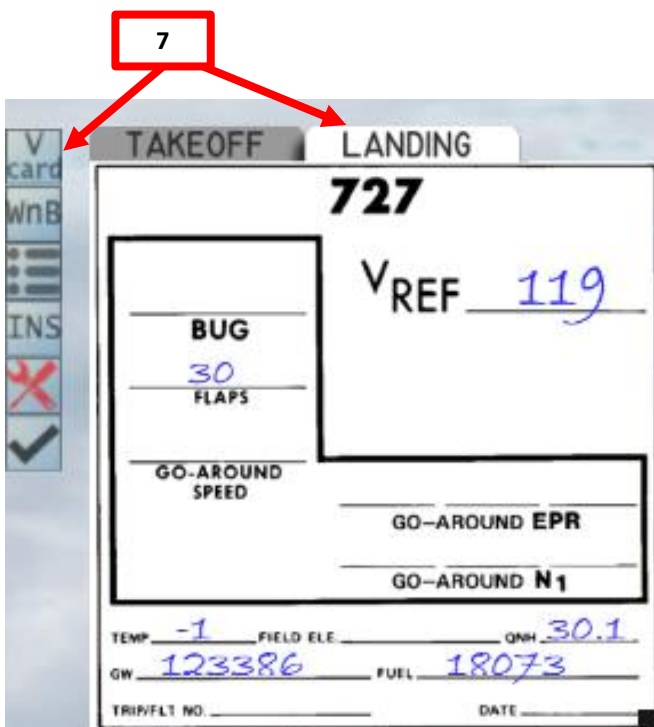

FINAL APPROACH



LANDING

- 1. At your Decision Height (200 ft), you will hear the « Minimums » audio cue. Below this altitude, you are now committed to land.
- 2. At 1500 ft, if autopilot remains engaged, the FLARE autopilot mode is armed. This indicates the auto-flare mode is armed if you want to use it.
- 3. At 200 ft, disengage autopilot and land manually.
- 4. Throttle back to IDLE and gently flare before touchdown.



3a

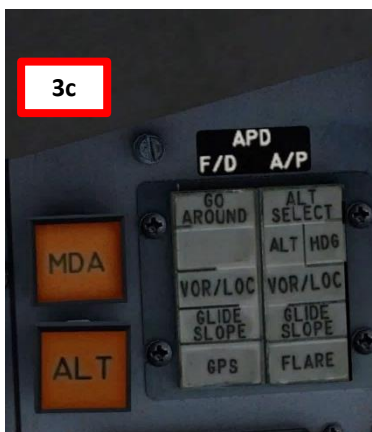

3c



2



3b

LANDING



15L-33R

LANDING



5. On touchdown, push the nose into the ground to improve adherence with the runway and maximize braking (the Autobrake system will already brake for you)

LANDING

6. Set the throttle at IDLE first, then press the “TOGGLE THRUST REVERSERS” binding. This will link your throttle axis to the thrust reverser lever axis.
7. Move your throttle forward to move the thrust reverser lever AFT. This will illuminate the REVERSER OPERATING lights and engage internal clam-shell thrust reversers to MAX REV. Deploy thrust reversers until you slow down enough to vacate the runway safely.
8. Once landed safely, set your throttle back to IDLE and press the “TOGGLE THRUST REVERSERS” binding again to reset your throttle axis.
9. Retract flaps and throttle up to taxi towards parking spot.

